

# NCP81246

## Three-Rail Controller with SVID Interface for IMVP8 CPU Applications

The NCP81246 contains a two-phase, and two single-phase buck regulators optimized for Intel IMVP8 compatible CPUs.

The two-phase controller combines true differential voltage sensing, differential inductor DCR current sensing, input voltage feed-forward, and adaptive voltage positioning to provide accurately regulated power for IMVP8 GT rails.

The two single-phase controllers can be used for Core, SA and GTUS rails. Both make use of ON Semiconductor's patented enhanced RPM operation. RPM control maximizes transient response while allowing for smooth transitions between discontinuous frequency scaling operation and continuous mode full power operation. The single-phase rails have an ultralow offset current monitor amplifier with programmable offset compensation for ultra high accuracy current monitoring.

The NCP81246 offers three internal MOSFET drivers with a single external PWM signal.

### Two-Phase Rail Features

- Dual Edge Modulation for Fastest Initial Response to Transient Loading
- High Performance Operational Error Amplifier
- Digital Soft Start Ramp
- Dynamic Reference Injection<sup>®</sup> (Patent #US7057381)
- Accurate Total Summing Current Amplifier (Patent #US6683441)
- Dual High Impedance Differential Voltage and Total Current Sense Amplifiers
- Phase-to-Phase Dynamic Current Balancing
- True Differential Current Balancing Sense Amplifiers for Each Phase
- Adaptive Voltage Positioning (AVP)
- Switching Frequency Range of 300 kHz – 750 kHz
- Vin range 4.5 V to 25 V
- Start-Up into Pre-Charged Loads While Avoiding False OVP
- UltraSonic Operation
- These Devices are Pb-Free, Halogen Free/BFR Free and are RoHS Compliant

### Single-Phase Rail Features

- Enhanced RPM Control System
- Ultra Low Offset IOU Monitor
- Dynamic VID Feed-Forward
- Programmable Droop Gain
- Zero Droop Capable
- Thermal Monitor
- UltraSonic Operation
- Adjustable Vboot
- Digitally Controlled Operating Frequency



ON Semiconductor<sup>®</sup>

[www.onsemi.com](http://www.onsemi.com)

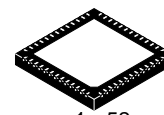

QFN52  
MN SUFFIX  
CASE 485BE

### MARKING DIAGRAM

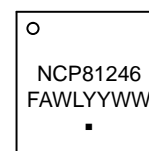

NCP81246 = Specific Device Code  
F = Wafer Fab  
A = Assembly Site  
WL = Lot ID  
YY = Year  
WW = Work Week  
▪ = Pb-Free Package

### ORDERING INFORMATION

Device	Package	Shipping <sup>†</sup>
NCP81246MNTXG	QFN52 (Pb-Free)	5000 / Tape & Reel

<sup>†</sup>For information on tape and reel specifications, including part orientation and tape sizes, please refer to our Tape and Reel Packaging Specification Brochure, BRD8011/D.

# NCP81246

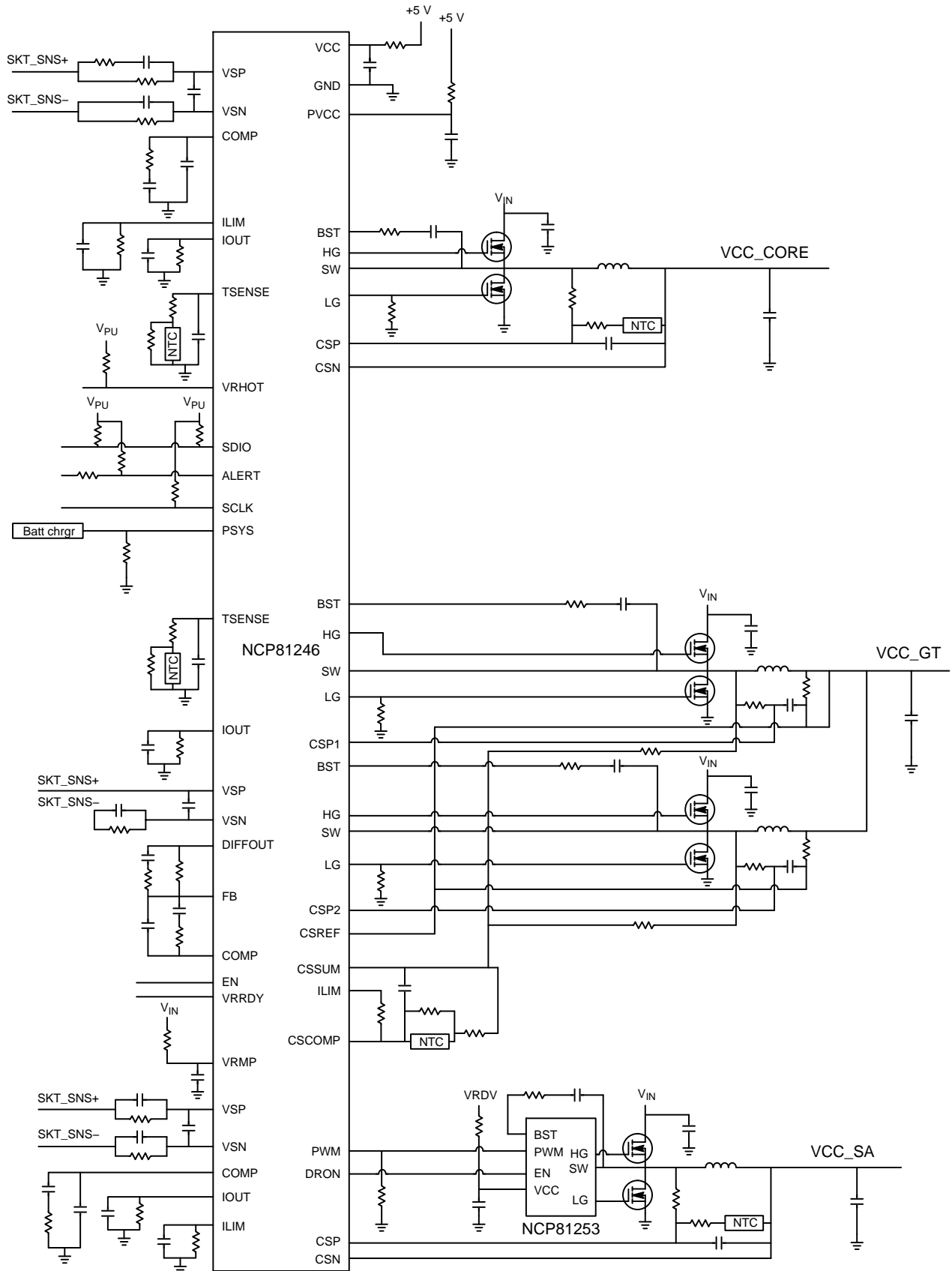

Figure 1. Application Schematic

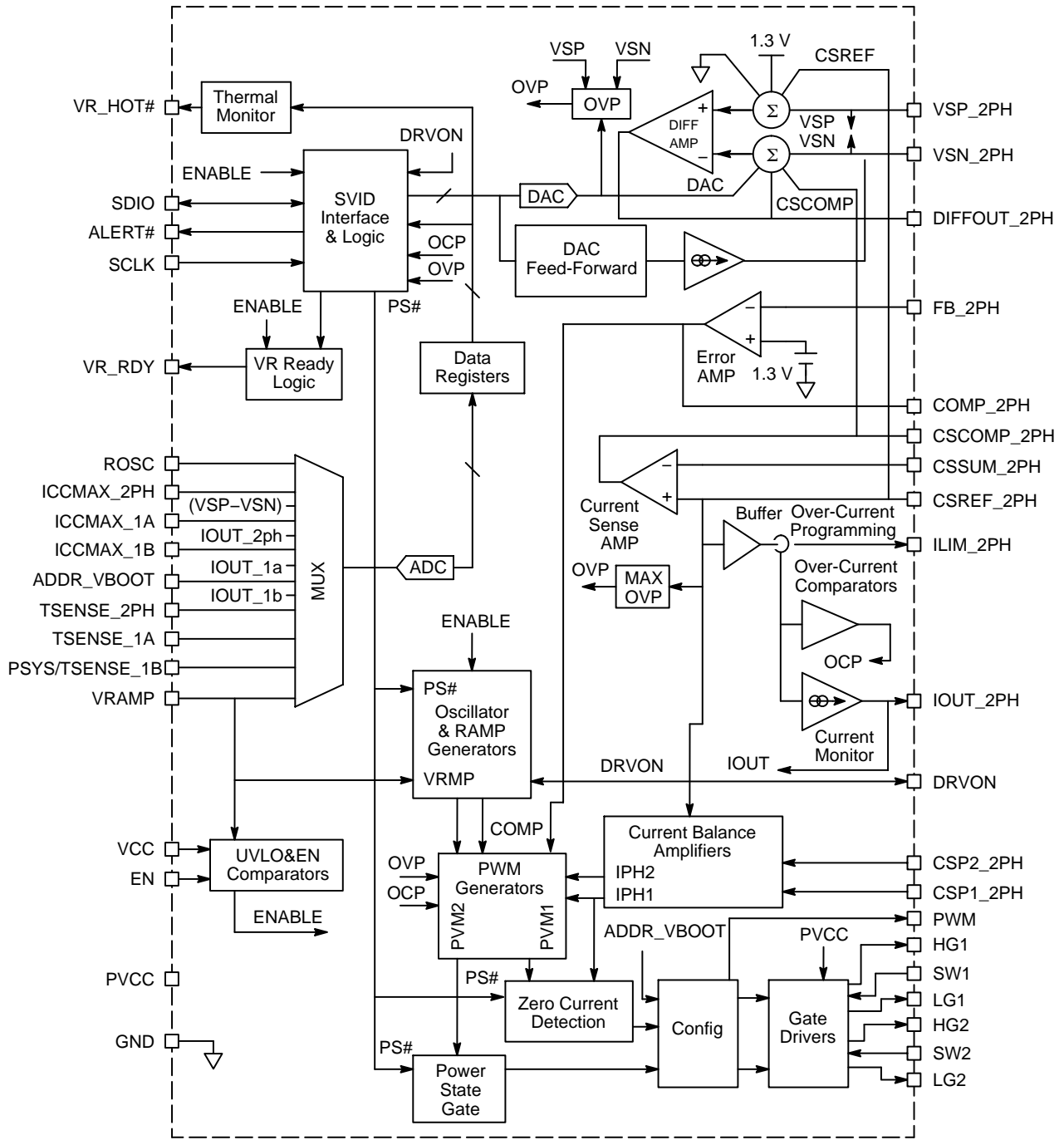

Figure 2. 2-Phase Rail Block Diagram

# NCP81246

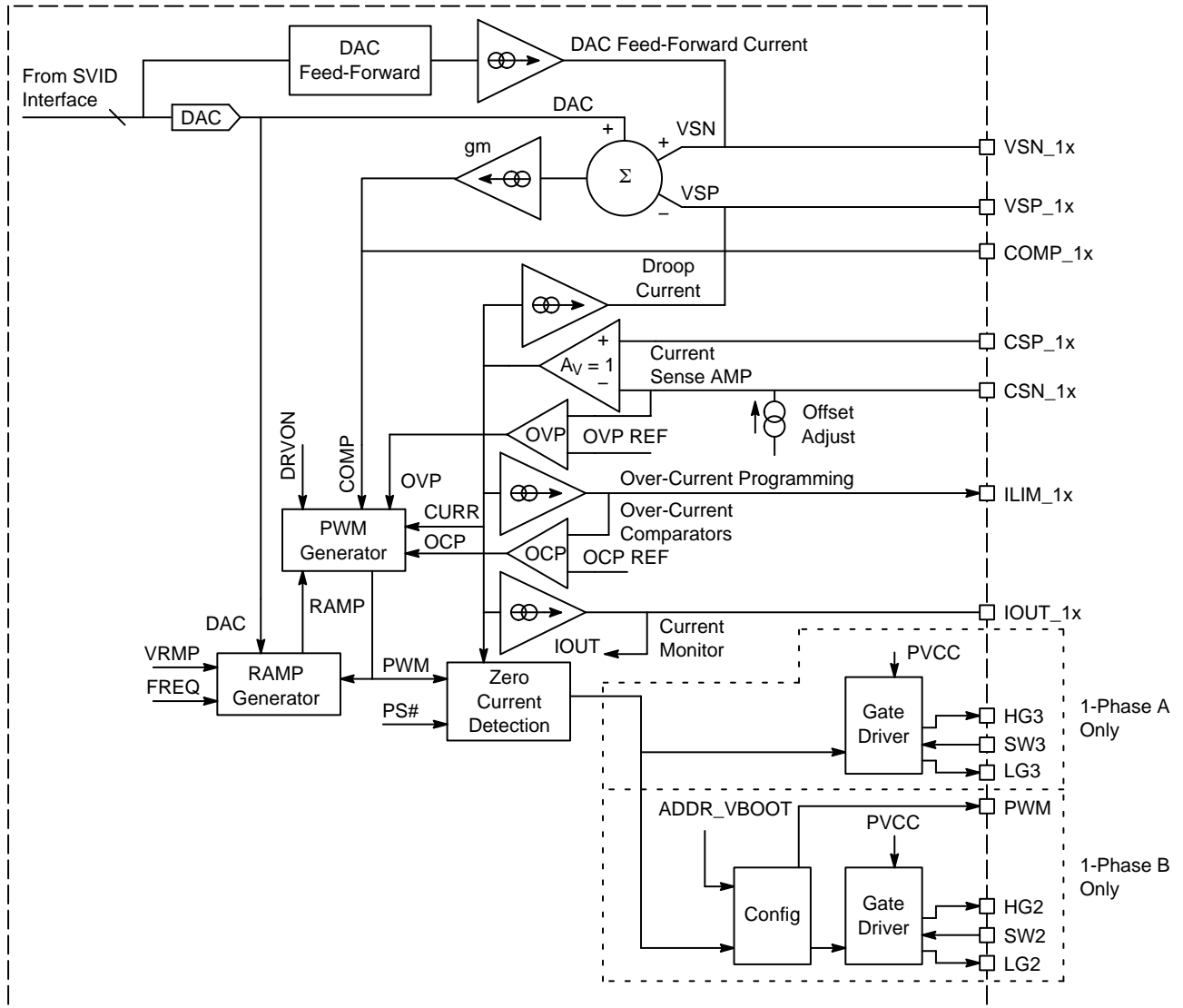
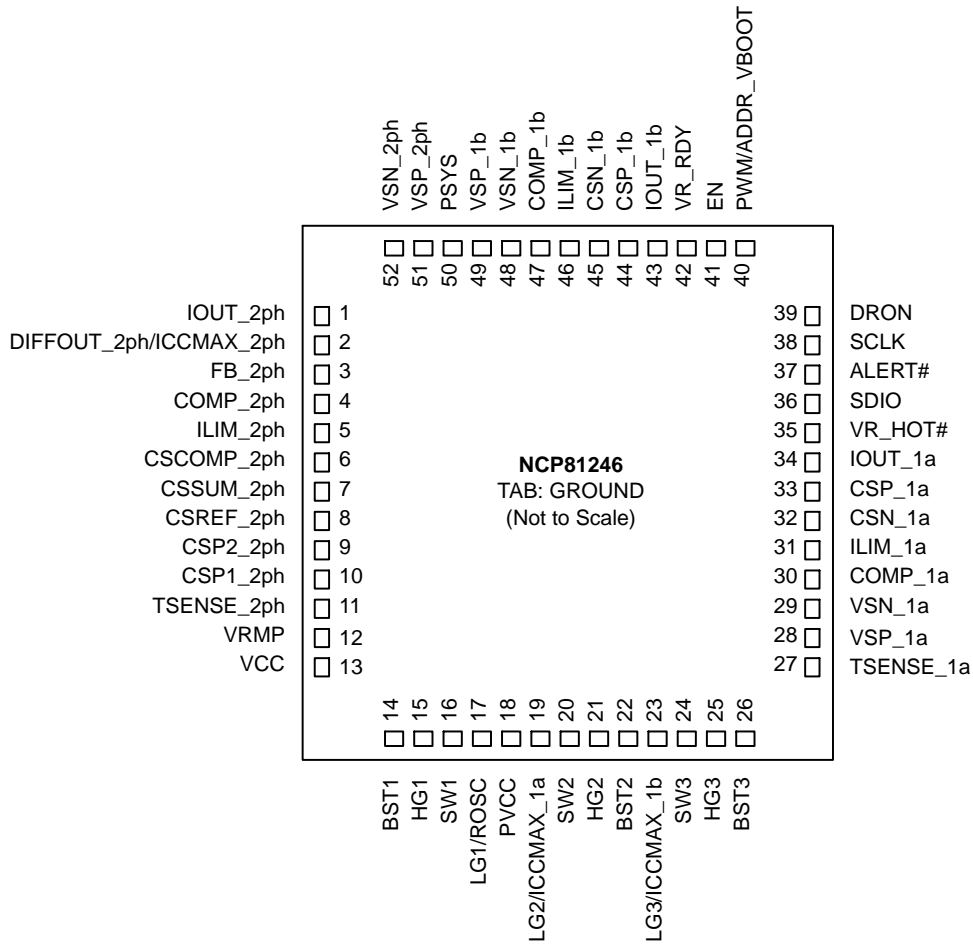

Figure 3. Single-Phase Block Diagram

# NCP81246



**Figure 4. Pin Configuration**

**Table 1. NCP81246 PIN DESCRIPTIONS**

Pin No.	Symbol	Description
1	IOUT_2ph	A resistor to ground programs IOUT gain for the two-phase regulator.
2	DIFFOUT_2ph/ ICCMAX_2ph	Output of the two-phase regulator's differential remote sense amplifier. During start-up, the two-phase regulator's ICCMAX is programmed with a pull-down on this pin.
3	FB_2ph	Error amplifier voltage feedback for two-phase regulator.
4	COMP_2ph	Output of the error amplifier and the inverting inputs of the PWM comparators for two-phase regulator.
5	ILIM_2ph	Over-current threshold setting – programmed with a resistor to CSCOMP_2ph for two-phase regulator.
6	CSCOMP_2ph	Output of total-current-sense amplifier for two-phase regulator.
7	CSSUM_2ph	Inverting input of total-current-sense amplifier for two-phase regulator.
8	CSREF_2ph	Total-current-sense amplifier reference voltage input for two-phase regulator.
9	CSP2_2ph	Non-inverting input to current-balance amplifier for Phase 2 of the two-phase regulator.
10	CSP1_2ph	Non-inverting input to current-balance amplifier for Phase 1 of the two-phase regulator.
11	TSENSE_2ph	Temperature sense input for the two-phase regulator.
12	VRMP	Feed-forward input of Vin for the ramp-slope compensation. The current fed into this pin is used to control the ramp of the PWM slopes.
13	VCC	Power for the internal control circuits. A decoupling capacitor is connected from this pin to ground.
14	BST1	High-side bootstrap supply for Phase 1 of the two-phase regulator.
15	HG1	High-side FET gate driver output for Phase 1 of the two-phase regulator.

# NCP81246

**Table 1. NCP81246 PIN DESCRIPTIONS** (continued)

Pin No.	Symbol	Description
16	SW1	Current return for high-side FET gate driver for Phase 1 of the two-phase regulator.
17	LG1/ROSC	Low-side FET gate driver output for Phase 1 of the two-phase regulator. During start-up ROSC is programmed with a pull-down resistor on this line.
18	PVCC	Power supply for all three internal FET gate drivers.
19	LG2/ICCMAX_1a	Low-side FET gate driver output for Phase 2 of the two-phase regulator, or output of single-phase regulator 1b. During start-up, regulator 1a's ICCMAX is programmed with a pull-down on this pin.
20	SW2	Current return for high-side FET gate driver for Phase 2 of the two-phase regulator, or for single-phase regulator 1b.
21	HG2	High-side FET gate driver output for Phase 2 of the two-phase regulator, or for single-phase regulator 1b.
22	BST2	High-side bootstrap supply for Phase 2 of the two-phase regulator, or for single-phase regulator 1b.
23	LG3/ICCMAX_1b	Low-side FET gate driver output for single-phase regulator 1a. During start-up, regulator 1b's ICCMAX is programmed with a pull-down on this pin.
24	SW3	Current return for high-side FET gate driver for single-phase regulator 1a.
25	HG3	High-side FET gate driver output for single-phase regulator 1a.
26	BST3	High-side bootstrap supply for single-phase regulator 1a.
27	TSENSE_1a	Temperature sense input for the single-phase regulators.
28	VSP_1a	Differential Output Voltage Sense Positive for single-phase regulator 1a.
29	VSN_1a	Differential Output Voltage Sense Negative for single-phase regulator 1a.
30	COMP_1a	Compensation for single-phase regulator 1a.
31	ILIM_1a	A resistor to ground programs the current-limit for single-phase regulator 1a.
32	CSN_1a	Differential current sense negative for single-phase regulator 1a.
33	CSP_1a	Differential current sense positive for single-phase regulator 1a.
34	IOUT_1a	A resistor to ground programs IOUT gain for single-phase regulator 1a.
35	VR_HOT#	Thermal logic output for over temperature.
36	SDIO	Serial VID data interface
37	ALERT#	Serial VID ALERT#
38	SCLK	Serial VID clock
39	DRON	Bi-directional FET driver enable
40	PWM/ ADDR_VBOOT	PWM output for phase 2 of the two-phase regulator or single-phase regulator 1b. During start-up, a resistor to ground programs SVID address and VBOOT options for all three rails.
41	EN	Enable. High enables all three rails.
42	VR_RDY	VR_RDY indicates all three rails are ready to accept SVID commands.
43	IOUT_1b	A resistor to ground programs IOUT gain for single-phase regulator 1b.
44	CSP_1b	Differential current sense positive for single-phase regulator 1b.
45	CSN_1b	Differential current sense negative for single-phase regulator 1b.
46	ILIM_1b	A resistor to ground programs the current-limit for single-phase regulator 1b.
47	COMP_1b	Compensation for single-phase regulator 1b.
48	VSN_1b	Differential Output Voltage Sense Negative for single-phase regulator 1b.
49	VSP_1b	Differential Output Voltage Sense Positive for single-phase regulator 1b.
50	PSYS/TSENSE_1b	System power signal input. Resistor to ground for scaling / Temperature sense input for the single-phase regulators.
51	VSP_2ph	Differential Output Voltage Sense Positive for the two-phase regulator.
52	VSN-2ph	Differential Output Voltage Sense Negative for the two-phase regulator.

# NCP81246

**Table 2. ABSOLUTE MAXIMUM RATINGS**

Pin Symbol	V <sub>MAX</sub>	V <sub>MIN</sub>	I <sub>SOURCE</sub>	I <sub>SINK</sub>
COMP_2ph	VCC + 0.3 V	-0.3 V	2 mA	2 mA
CSCOMP_2ph	VCC + 0.3 V	-0.3 V	2 mA	2 mA
VSN_2ph	GND + 0.3 V	GND - 0.3 V	1 mA	1 mA
DIFFOUT_2ph / IccMax_2ph	VCC + 0.3 V	-0.3 V	2 mA	2 mA
VCC	6.5 V	-0.3 V	100 mA	100 mA
PVCC	6.5 V	-0.3 V	100 mA	100 mA
VRMP	25 V	-0.3 V	100 mA	100 mA
SW_x	35 V 40 V ≤ 50 ns	-5 V	100 mA	100 mA
BST_x	35 V wrt / GND 40 V ≤ 50 ns wrt / GND 6.5 V wrt / SW	-0.3 V wrt / SW	100 mA	100 mA
LG_x / ICCMAX_x	VCC + 0.3 V	-0.3 V -2 V ≤ 200 ns	100 mA	100 mA
HG_x	BST + 0.3 V	-0.3 V wrt / SW -2 V ≤ 200 ns wrt / SW	100 mA	100 mA
All Other Pins	VCC + 0.3 V	-0.3 V	100 mA	100 mA

Stresses exceeding those listed in the Maximum Ratings table may damage the device. If any of these limits are exceeded, device functionality should not be assumed, damage may occur and reliability may be affected.

\*All signals referenced to GND unless noted otherwise.

**Table 3. THERMAL INFORMATION**

Description	Symbol	Value	Unit
Thermal Characteristic QFN Package (Note 1)	R <sub>θJA</sub>	68	°C/W
Operating Junction Temperature Range (Note 2)	T <sub>J</sub>	-40 to +125	°C
Operating Ambient Temperature Range		-40 to +100	°C
Maximum Storage Temperature Range	T <sub>STG</sub>	-40 to +150	°C
Moisture Sensitivity Level QFN Package	MSL	1	

\*The maximum package power dissipation must be observed.

1. JESD 51-5 (1S2P Direct-Attach Method) with 0 LFM
2. JESD 51-7 (1S2P Direct-Attach Method) with 0 LFM

**Table 4. ELECTRICAL CHARACTERISTICS – GENERAL**

(Unless otherwise stated: -40°C < T<sub>A</sub> < 100°C; 4.75 V < VCC < 5.25 V; C<sub>VCC</sub> = 0.1 μF)

Parameter	Test Conditions	Min	Typ	Max	Unit	
<b>BIAS SUPPLY</b>						
VCC Voltage Range		4.75	-	5.25	V	
VCC Quiescent Current	EN = High	PS0, PS1, PS2	-	26	-	mA
		PS3	-	23	-	mA
		PS4	-	145	200	μA
	EN = Low		-	20	-	μA
VCC UVLO	VCC Rising	-	-	4.5	V	
	VCC Falling	4	-	-	V	
PVCC Voltage Range		4.75	-	5.25	V	
PVCC Quiescent Current	EN = Low (Shutdown)	-	-	1	μA	
	EN = High, No Switching	-	-	1.5	mA	
VRAMP Voltage Range		5	-	20	V	
VRAMP UVLO	VRAMP Rising	-	-	4.25	V	
	VRAMP Falling	3	-	-	V	

# NCP81246

**Table 4. ELECTRICAL CHARACTERISTICS – GENERAL** (continued)

(Unless otherwise stated:  $-40^{\circ}\text{C} < T_A < 100^{\circ}\text{C}$ ;  $4.75\text{ V} < V_{CC} < 5.25\text{ V}$ ;  $C_{VCC} = 0.1\ \mu\text{F}$ )

Parameter	Test Conditions	Min	Typ	Max	Unit	
<b>ENABLE INPUT</b>						
Upper Threshold		0.8	–	–	V	
Lower Threshold		–	–	0.3	V	
Enable Delay Time		–	–	2.5	ms	
Enable High Input Leakage Current		–	–	0.5	$\mu\text{A}$	
<b>PHASE DETECTION</b>						
CSP Pin Threshold Voltage		–	–	4.5	V	
Phase Detect Timer		–	1.75	–	ms	
<b>DAC SLEW RATE</b>						
Soft Start Slew Rate		–	15	–	$\text{mV}/\mu\text{s}$	
Slew Rate Slow		–	15	–	$\text{mV}/\mu\text{s}$	
Slew Rate Fast		–	30	–	$\text{mV}/\mu\text{s}$	
<b>DRVON</b>						
Output High Voltage		3	–	–	V	
Output Low Voltage		–	–	0.1	V	
Rise Time	$C_L$ (PCB) = 20 pF $\Delta V_o = 10\%$ to 90%	–	100	–	ns	
Fall Time		–	2.5	–	ns	
Internal Pull-Down Resistance	EN = Low	–	69.5	–	$\text{k}\Omega$	
<b>T<sub>SENSE</sub></b>						
Bias Current	$-40^{\circ}\text{C}$ to $100^{\circ}\text{C}$	115	120	125	$\mu\text{A}$	
Alert# Assert Threshold		–	485	–	mV	
Alert# De-Assert Threshold		–	513	–	mV	
VR_Hot Assert Threshold		–	466	–	mV	
VR_Hot De-Assert Threshold		–	490	–	mV	
<b>VR_Rdy OUTPUT</b>						
Output Low Saturation Voltage	IVR_RDY = –4 mA	–	–	0.3	V	
Output Leakage Current When High	VR_RDY = 5 V	–1	–	1	$\mu\text{A}$	
Rise Time	1 $\text{k}\Omega$ Pull-Up to 3.3 V $C_{TOT} = 45\text{ pF}$	–	$\Delta V_o = 10\%$ to 90%	110	–	ns
Fall Time			$\Delta V_o = 90\%$ to 10%	20	–	ns
VR_Rdy Delay Rising	EN rising to VR_RDY rising	–	–	2.5	ms	
VR_Rdy Delay Falling	Due to OVP	–	0.3	–	$\mu\text{s}$	
	Due to OCP	–	50	–	$\mu\text{s}$	
	EN falling to VR_RDY falling (TD+TE)	–	–	1.5	$\mu\text{s}$	
<b>VR_Hot#</b>						
Output Low Saturation Voltage	IVR_HOT = –4 mA	–	–	0.3	V	
Output Leakage Current When High	VR_HOT = 5 V	–1	–	1	$\mu\text{A}$	
<b>ADC</b>						
Linear Input Voltage Range		0	–	2	V	
Differential Non-Linearity (DNL)	8-Bits	–	–	1	LSB	
Total Unadjusted Error (TUE)		–1	–	1	%	
Conversion Time		–	10	–	$\mu\text{s}$	
Conversion Rate		–	33	–	kHz	
Power Supply Sensitivity		–	$\pm 1$	–	%	
Round Robin		–	90	–	$\mu\text{s}$	



# NCP81246

**Table 4. ELECTRICAL CHARACTERISTICS – GENERAL** (continued)

(Unless otherwise stated:  $-40^{\circ}\text{C} < T_A < 100^{\circ}\text{C}$ ;  $4.75\text{ V} < V_{CC} < 5.25\text{ V}$ ;  $C_{VCC} = 0.1\ \mu\text{F}$ )

Parameter	Test Conditions	Min	Typ	Max	Unit
<b>IccMax</b>					
Bias Current		9.7	10	10.3	$\mu\text{A}$
Full scale input voltage		–	2.0	–	V
<b>OVP and UVP</b>					
Absolute Over Voltage Threshold	During Soft Start	–	2.0	–	V
Over Voltage Threshold Above DAC	VSP–VSN–VID Rising	360	400	440	mV
Over Voltage Delay	VSP–VSN Rising to PWM Low	–	25	–	ns
Under Voltage Threshold Below DAC	VSP–VSN–VID Falling	–	300	–	mV
Under Voltage Delay		–	5	–	$\mu\text{s}$
<b>OSCILLATOR</b>					
Switching Frequency Range		300	–	750	kHz
Switching Frequency Accuracy		–	$\pm 10$	–	%
<b>PWM OUTPUT</b>					
Output High Voltage	Sourcing 500 $\mu\text{A}$	$V_{CC} - 0.2$	–	–	V
Output Mid Voltage	No Load, Power State 2	1.9	2	2.1	V
Output Low Voltage	Sinking 500 $\mu\text{A}$	–	–	0.7	V
Rise Time	$C_L$ (PCB) = 50 pF	$\Delta V_o = 10\%$ to 90%	–	5	ns
Fall Time		$\Delta V_o = 90\%$ to 10%	–	5	ns
<b>HIGH-SIDE MOSFET DRIVER</b>					
Pull-Up Resistance, Sourcing Current	BST = PVCC	–	1.4	2.5	$\Omega$
Pull-Down Resistance, Sinking Current	BST = PVCC	–	0.9	2	$\Omega$
HG Rise Time	PVCC = 5 V, $C_L = 3\text{ nF}$ , BST–SW = 5 V	6	12	27	ns
HG Fall Time	PVCC = 5 V, $C_L = 3\text{ nF}$ , BST–SW = 5 V	6	11	15	ns
HG Turn ON Propagation Delay tpdhDRVH	$C_L = 3\text{ nF}$	13	16	21	ns
SW Pull-Down Resistance	SW to GND	–	2	–	k $\Omega$
HG Pull-Down Resistance	HG to SW, BST – SW = 0 V	–	292	–	k $\Omega$
<b>LOW-SIDE MOSFET DRIVER</b>					
Pull-Up Resistance, Sourcing Current		–	1.6	3.5	$\Omega$
Pull-Down Resistance, Sinking Current		–	0.5	1.5	$\Omega$
LGx Rise Time	3 nF Load	6	18	27	ns
LGx Fall Time	3 nF Load	6	12	25	ns
Dead-Time		–	–	–	
LGx Turn-On Propagation Delay tpdhDRVL	$C_{LOAD} = 3\text{ nF}$	–	14	20	ns
<b>BOOST RECTIFIER</b>					
RON	EN = Low or EN = High and DRVL = HIGH	5	13	22	$\Omega$

Product parametric performance is indicated in the Electrical Characteristics for the listed test conditions, unless otherwise noted. Product performance may not be indicated by the Electrical Characteristics if operated under different conditions.

3. Based on design or characterisation data, not in production test.

# NCP81246

**Table 5. ELECTRICAL CHARACTERISTICS – 2-PHASE RAIL SPECIFIC**

(Unless otherwise stated:  $-40^{\circ}\text{C} < T_A < 100^{\circ}\text{C}$ ;  $4.75\text{ V} < V_{CC} < 5.25\text{ V}$ ;  $C_{VCC} = 0.1\ \mu\text{F}$ )

Parameter	Test Conditions	Min	Typ	Max	Unit
<b>DIFFERENTIAL SUMMING AMP</b>					
Input Bias Current	VSP = VSN = 1.3 V	-25	-	25	nA
VSP Input Voltage Range		-0.3	-	3	V
VSN Input Voltage Range		-0.3	-	0.3	V
-3dB Bandwidth	$C_L = 20\ \text{pF}$ , $R_L = 10\ \text{k}\Omega$	-	22.5	-	MHz
Closed Loop DC Gain	VSP – VSN = 0.5 V to 1.3 V	-	1	-	V/V
<b>ERROR AMPLIFIER</b>					
Input Bias Current	@1.3 V	-400	-	400	nA
Open Loop DC Gain	$C_L = 20\ \text{pF}$ , $R_L = 10\ \text{k}\Omega$	-	80	-	dB
Open Loop Unity Gain Bandwidth	$C_L = 20\ \text{pF}$ , $R_L = 10\ \text{k}\Omega$	-	20	-	MHz
Slew Rate	$\Delta V_{IN} = 100\ \text{mV}$ , $G = -10\ \text{V/V}$ $\Delta V_{OUT} = 1.5\ \text{V}$ to $2.5\ \text{V}$ , $C_L = 20\ \text{pF}$ , $R_L = 10\ \text{k}\Omega$	-	5	-	V/ $\mu\text{s}$
Maximum Output Voltage	$I_{SOURCE} = 2.0\ \text{mA}$	4	-	-	V
Minimum Output Voltage	$I_{SINK} = 2.0\ \text{mA}$	-	-	0.9	V
<b>CURRENT SUMMING AMPLIFIER</b>					
Input Bias Current	CSSUM = CSREF = 1.0 V	-8	-	8	$\mu\text{A}$
Offset Voltage (Vos) (Note 4)		-2.5	-	2.5	mV
Open Loop Gain		-	80	-	dB
Open Loop Unity Gain Bandwidth	$C_L = 20\ \text{pF}$ , $R_L = 10\ \text{k}\Omega$	-	10	-	MHz
Maximum Output Voltage	$I_{SOURCE} = 2.0\ \text{mA}$	3.5	-	-	V
Minimum Output Voltage	$I_{SINK} = 0.5\ \text{mA}$	-	-	0.1	V
<b>CURRENT BALANCE AMPLIFIERS</b>					
Input Bias Current	CSP1/2 = CSREF = 1.2 V	-50	-	50	nA
Common Mode Input Voltage Range	CSP1/2 = CSREF	0	-	2.3	V
Differential Mode Input Voltage Range	CSREF = 1.2 V	-100	-	100	mV
Input Offset Voltage Matching	CSP1/2 = CSREF = 1.2 V Measured from Average.	-1.6	-	1.6	mV
Current Sense Amplifier Gain	$0\ \text{V} < \text{CSP1/2} - \text{CSREF} < 0.1\ \text{V}$	5.7	6	6.3	V/V
Multiphase Current Sense Gain Matching	CSP1/2 = CSREF = 10 mV to 30 mV	-3.5	-	3.5	%
-3dB Bandwidth		-	6	-	MHz
<b>OVER-CURRENT PROTECTION</b>					
$I_{LIM}$ Threshold Current (Delayed OCP Shutdown)	PS0	8.5	10	11.5	$\mu\text{A}$
	PS1, PS2, PS3	-	6.67	-	$\mu\text{A}$
$I_{LIM}$ Threshold Current (Immediate OCP Shutdown)	PS0	13	15	17	$\mu\text{A}$
	PS1, PS2, PS3	-	10	-	$\mu\text{A}$
Shutdown Delay	Immediate	-	300	-	ns
Shutdown Delay	Delayed	-	50	-	$\mu\text{s}$
$I_{LIM}$ Output Voltage Offset	$I_{LIM}$ sourcing $15\ \mu\text{A}$ Measured relative to CSREF	-1.5	-	1.5	mV

# NCP81246

**Table 5. ELECTRICAL CHARACTERISTICS – 2-PHASE RAIL SPECIFIC** (continued)

(Unless otherwise stated:  $-40^{\circ}\text{C} < T_A < 100^{\circ}\text{C}$ ;  $4.75\text{ V} < V_{CC} < 5.25\text{ V}$ ;  $C_{VCC} = 0.1\ \mu\text{F}$ )

Parameter	Test Conditions	Min	Typ	Max	Unit
<b>I<sub>OUT</sub> OUTPUT</b>					
Output Offset Current	$V_{ILIM} = 5\text{ V}$	–	–	0.25	$\mu\text{A}$
Output Source Current	$I_{LIM}$ Source Current = 20 $\mu\text{A}$	–	200	–	$\mu\text{A}$
Current Gain	$I_{IOUT} / I_{LIM}$ , $R_{LIM} = 20\text{ k}\Omega$ , $R_{IOUT} = 5\text{ k}\Omega$ DAC = 0.8 V, 1.25 V, 1.52 V	9.5	10	10.5	A/A

## MODULATORS

0% Duty Cycle	Comp Voltage for PWM Held Low	–	1.3	–	V
100% Duty Cycle	Comp Voltage for PWM Held High $VRAMP = 12\text{ V}$	–	2.6	–	V
PWM Ramp Duty Cycle Matching	Comp = 2 V, PWM $T_{ON}$ Matching	–	$\pm 3$	–	%
PWM Phase Angle Error		–	$\pm 15$	–	$^{\circ}$
Ramp Feed Forward Voltage Range		5	–	20	V

Product parametric performance is indicated in the Electrical Characteristics for the listed test conditions, unless otherwise noted. Product performance may not be indicated by the Electrical Characteristics if operated under different conditions.

4. Based on design or characterisation data, not in production test.

**Table 6. ELECTRICAL CHARACTERISTICS – SINGLE PHASE RAIL SPECIFIC**

(Unless otherwise stated:  $-40^{\circ}\text{C} < T_A < 100^{\circ}\text{C}$ ;  $4.75\text{ V} < V_{CC} < 5.25\text{ V}$ ;  $C_{VCC} = 0.1\ \mu\text{F}$ )

Parameter	Test Conditions	Min	Typ	Max	Unit
<b>ERROR AMPLIFIER</b>					
Input Bias Current		–25	–	25	nA
VSP Input Voltage Range		–0.3	–	3	V
VSN Input Voltage Range		–0.3	–	0.3	V
gm		1.3	1.6	2.0	mS
Output Offset		–15	–	15	$\mu\text{A}$
Open Loop Gain	$Z_L = (1\text{ nF} + 1\text{ k}\Omega) \parallel 10\text{ pF}$	–	73	–	dB
Source Current	$\Delta V_{IN} = -200\text{ mV}$	–	200	–	$\mu\text{A}$
Sink Current	$\Delta V_{IN} = 200\text{ mV}$	–	200	–	$\mu\text{A}$
–3dB Bandwidth	$Z_L = (1\text{ nF} + 1\text{ k}\Omega) \parallel 10\text{ pF}$	–	20	–	MHz

## CURRENT SENSE AMPLIFIER

Input Bias Current	$CSP = CSN = 1.2\text{ V}$	–50	–	50	nA
Common Mode Input Voltage Range	$CSP = CSN$	0	–	2.3	V
Common Mode Rejection	$CSP = CSN = 0.5\text{ V to } 1.2\text{ V}$	60	80	–	dB
Differential Mode Input Voltage Range	$CSN = 1.2\text{ V}$	–100	–	100	mV
Gain $I_{OUT}$ Output	$0\text{ V} \leq CSP - CSN \leq 0.1\text{ V}$	0.96	1	1.04	mS
Gain VSP and $I_{LIM}$ Outputs	$0\text{ V} \leq CSP - CSN \leq 0.1\text{ V}$	0.96	1	1.04	mS
–3dB Bandwidth		–	6	–	MHz

## OVER-CURRENT PROTECTION

Output Offset Current	$V_{ILIM} = 1.3\text{ V}$	–1.5	–	1.5	$\mu\text{A}$
Maximum Output Current	$0\text{ V} \leq V_{ILIM} \leq 1.3\text{ V}$	130	–	–	$\mu\text{A}$
Maximum Output Voltage	$I_{LIM} = 100\ \mu\text{A}$	1.4	–	–	V
Activation Threshold Voltage		1.28	1.3	1.32	V
Activation Delay		–	250	–	ns

## I<sub>OUT</sub>

Output Offset Current	$0\text{ V} \leq V_{IOUT} \leq 2.0\text{ V}$	–250	–	250	nA
-----------------------	--	------	---	-----	----

# NCP81246

**Table 6. ELECTRICAL CHARACTERISTICS – SINGLE PHASE RAIL SPECIFIC** (continued)

(Unless otherwise stated:  $-40^{\circ}\text{C} < T_A < 100^{\circ}\text{C}$ ;  $4.75\text{ V} < V_{CC} < 5.25\text{ V}$ ;  $C_{VCC} = 0.1\ \mu\text{F}$ )

Parameter	Test Conditions	Min	Typ	Max	Unit
<b>I<sub>OUT</sub></b>					
Maximum Output Current	$0\text{ V} \leq V_{IOUT} \leq 2.0\text{ V}$	130	–	–	$\mu\text{A}$
Maximum Output Voltage	$I_{IOUT} = 100\ \mu\text{A}$	2.1	–	–	V

**DROOP**

Output Offset Current 1A	$0\text{ V} \leq V_{DROOP} \leq 1.8\text{ V}$	-1800	–	1800	nA
Output Offset Current 1B	$0\text{ V} \leq V_{DROOP} \leq 1.8\text{ V}$	-900	–	900	nA
Maximum Output Current	$0\text{ V} \leq V_{DROOP} \leq 1.8\text{ V}$	130	–	–	$\mu\text{A}$
Maximum Output Voltage	$I_{DROOP} = 100\ \mu\text{A}$	1.8	–	–	V

**ZCD COMPARATOR**

Offset Accuracy	Referred to CSP – CSN	–	$\pm 1.5$	–	mV
-----------------	-----------------------	---	-----------	---	----

Product parametric performance is indicated in the Electrical Characteristics for the listed test conditions, unless otherwise noted. Product performance may not be indicated by the Electrical Characteristics if operated under different conditions.

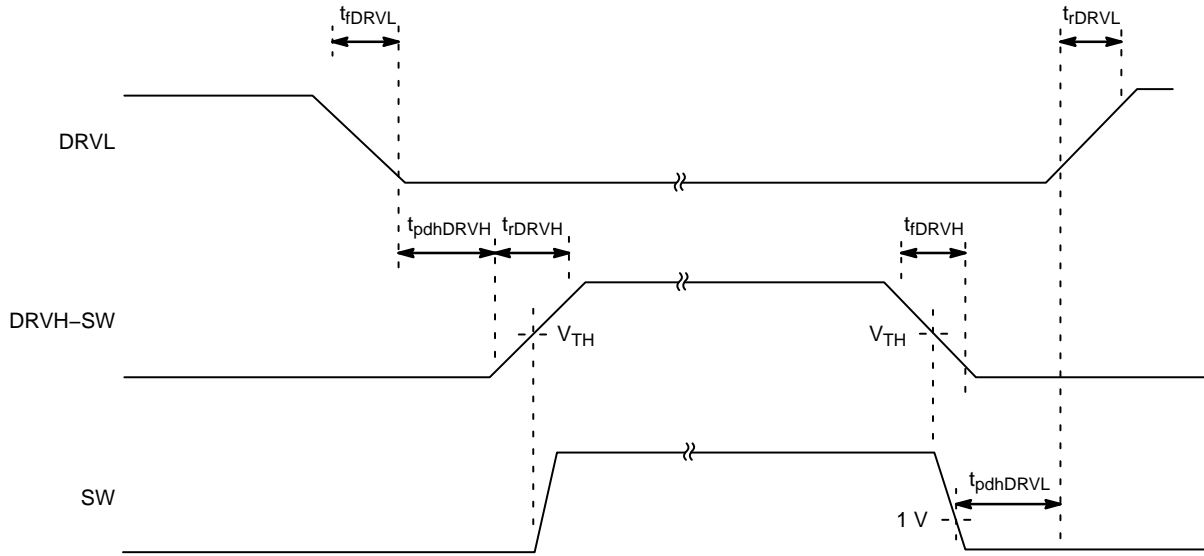

NOTE: Timing is referenced to the 10% and the 90% points, unless otherwise stated.

**Figure 5. Driver Timing Diagram**

# NCP81246

**Table 7. STATE TRUTH TABLE**

State	VR_RDY Pin	Error AMP Comp Pin	OVP & UVP	DRON Pin	Method of Reset
<b>POR</b> 0 < VCC < UVLO	N/A	N/A	N/A	Resistive Pull Down	
<b>Disabled</b> EN < Threshold UVLO > Threshold	Low	Low	Disabled	Low	
<b>Start-Up Delay &amp; Calibration</b> EN > Threshold UVLO > Threshold	Low	Low	Disabled	Low	
<b>DRON Fault</b> EN > Threshold UVLO > Threshold DRON < Threshold	Low	Low	Disabled	Resistive Pull Up	Driver Must Release DRON to High
<b>Soft Start</b> EN > Threshold UVLO > Threshold DRON > High	High	Operational	Active/No Latch	High	
<b>Normal Operation</b> EN > Threshold UVLO > Threshold DRON > High	High	Operational	Active/Latching	High	N/A
<b>Over Voltage</b>	Low	N/A	DAC+OVP	High	
<b>Over Current</b>	Low	Operational	Last DAC Code	Low	
<b>Vout = 0 V</b>	Low: if Reg34h: bit 0 = 0; High: if Reg34h: bit 0 = 1;	Clamped at 0.9 V	Disabled	High, PWM Outputs in Low State	

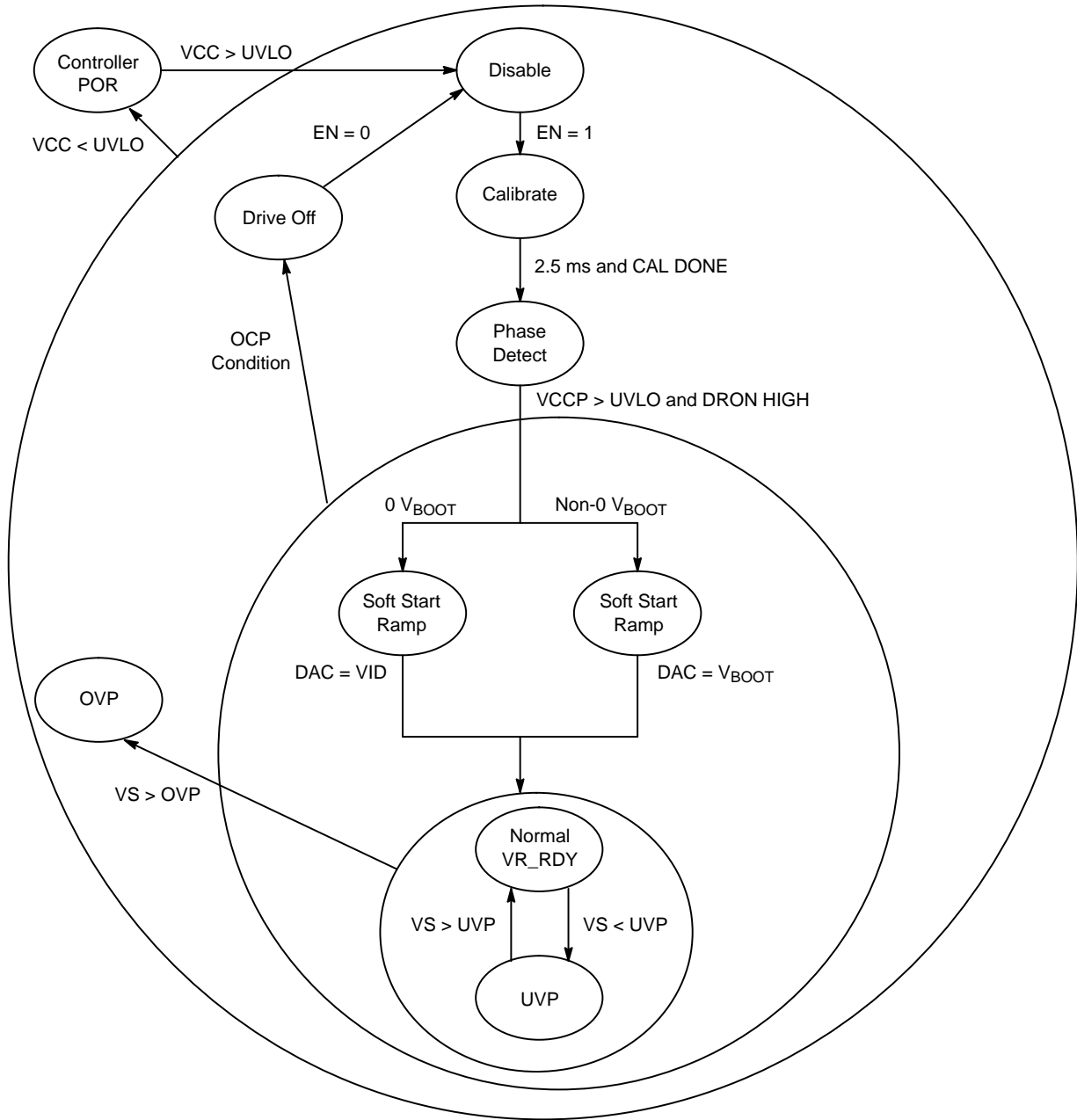

Figure 6. State Diagram

# NCP81246

## GENERAL

### Configuration

The NCP81246 is a three-rail IMVP8 controller, with three internal drivers. The NCP81246 is configured with the two-phase, dual-edge controller providing VGT.

Table 8 shows the available configurations, and the pull-down resistor required on Pin 40 (PWM/ ADDR\_VBOOT) to configure them.

**Table 8. CONFIGURATIONS**

R (kΩ)	2ph		Ph1	Ph2		TSENSE	1ph A				1ph B				
	Addr	V <sub>BOOT</sub> (V)	D <sub>RV1</sub>	D <sub>RV2</sub>	PWM		Addr	V <sub>BOOT</sub> (V)	D <sub>RV3</sub>	TSENSE	Addr	V <sub>BOOT</sub> (V)	D <sub>RV2</sub>	PWM	TSENSE
10	1	0	x		x	2ph	0	0	x	1a	2	1	x		N/A (P <sub>sys</sub> )
16.2	1	1.2	x		x	2ph	0	1.2	x	1a	2	1	x		N/A (P <sub>sys</sub> )
22.1	1	0	x		x	2ph	0	0	x	1a	2	1.05	x		N/A (P <sub>sys</sub> )
28.7	1	0	x		x	2ph	0	0	x	1a	2	0.95	x		N/A (P <sub>sys</sub> )
35.7	1	0	x	x		2ph	0	0	x	1a	2	1		x	N/A (P <sub>sys</sub> )
43.2	1	1.2	x	x		2ph	0	1.2	x	1a	2	1		x	N/A (P <sub>sys</sub> )
51.1	1	0	x	x		2ph	0	0	x	1a	2	1.05		x	N/A (P <sub>sys</sub> )
61.9	1	0	x	x		2ph	0	0	x	1a	2	0.95		x	N/A (P <sub>sys</sub> )
71.5	1	0	x	x		2ph	2	1	x	N/A (P <sub>sys</sub> )	0	0		x	1a
82.5	1	1.2	x	x		2ph	2	1	x	N/A (P <sub>sys</sub> )	0	1.2		x	1a
95.3	1	0	x	x		2ph	2	1.05	x	N/A (P <sub>sys</sub> )	0	0		x	1a
110	1	0	x	x		2ph	2	0.95	x	N/A (P <sub>sys</sub> )	0	0		x	1a
127	1	0	x	x		2ph	3	0	x	1a	0	0		x	1b
143	1	1.2	x	x		2ph	3	1.2	x	1a	0	1.2		x	1b
165	1	0	x	x		2ph	3	0	x	1a	0	0		x	1b
187	1	0	x	x		2ph	3	0	x	1a	0	0		x	1b

### Switching Frequency F<sub>sw</sub>

F<sub>sw</sub> is programmed on start-up with a pull-down on the LG1 pin.

**Table 9. SWITCHING FREQUENCY**

Resistor	Core/GT	SA
6.81 kΩ	750 kHz	750 kHz
14 kΩ	600 kHz	600 kHz
21.5 kΩ	450 kHz	600 kHz
28.7 kΩ	300 kHz	450 kHz

### Serial VID Interface (SVID)

For SVID interface communication details please contact Intel<sup>®</sup>, Inc.

**Interleaving**

In order to minimize stress on the input voltage and simplify input filter design, the NCP81246 monitors the phase-angle relationship between the rails used for Core and GT. Small adjustments are made to keep phases of both rails from turning on at the same time. Priority is given to transient response, i.e. if a phase must turn on to respond to a load increase, the phase will not be gated if the other rail has a phase that is turned on. The feature is intended to reduce loading on the input rail during steady-state conditions. If either rail is operating in DCM mode, this feature will be disabled.

**Ultra-Sonic Mode**

Ultra-Sonic Mode forces a minimum switching frequency above audible range when a rail is in DCM mode.

**Two-Phase Rail Voltage Compensation**

The remote Sense Amplifier output is applied to a Type III compensation network formed by the error amplifier and external tuning components. The non-inverting input of the error amplifier is connected to the same reference voltage used to bias the Remote sense amplifier output.

**Two-Phase Rail Remote Sense Amplifier**

A high performance high input impedance true differential amplifier is provided to accurately sense the output voltage of the regulator. The VSP and VSN inputs should be connected to the regulator’s output voltage sense points. The remote sense amplifier takes the difference of the output voltage with the DAC voltage and adds the droop voltage to

$$V_{DIFFOUT} = (V_{VSP} + V_{VSN}) + (1.3\text{ V} - V_{DAC}) + (V_{DROOP} + V_{CSREF}) \tag{eq. 1}$$

This signal then goes through a standard error compensation network and into the inverting input of the error amplifier. The non-inverting input of the error amplifier is connected to the same 1.3 V reference used for the differential sense amplifier output bias.

**Two-Phase Rail High Performance Voltage Error Amplifier**

A high performance error amplifier is provided for high bandwidth transient performance. A standard type III compensation circuit is normally used to compensate the system.

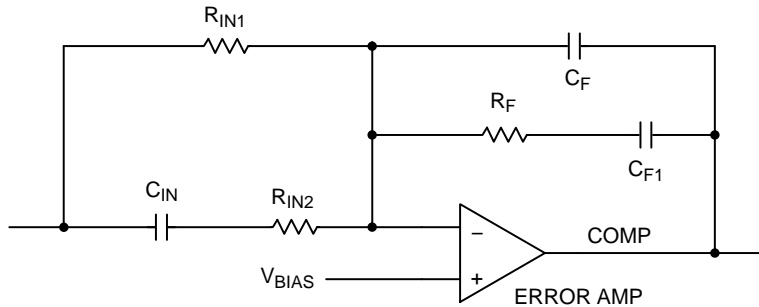

Figure 7. Standard Type III Compensation Circuit



**Differential Current Feedback Amplifiers**

Each phase of the two-phase rail has a low offset differential amplifier to sense that phase current for current balance and per phase OCP protection during soft-start. The inputs to the CSNx and CSPx pins are high impedance inputs. It is recommended that any external filter resistor RCSN does not exceed 10 kΩ to avoid offset issues with leakage current. It is also recommended that the voltage

sense element be no less than 0.5 mΩ for accurate current balance. Fine tuning of this time constant is generally not required. The individual phase current is summed into the PWM comparator feedback this way current is balanced via a current mode control approach.

$$R_{CSN} = \frac{L_{PHASE}}{C_{CSN} \cdot DCR} \quad (\text{eq. 2})$$

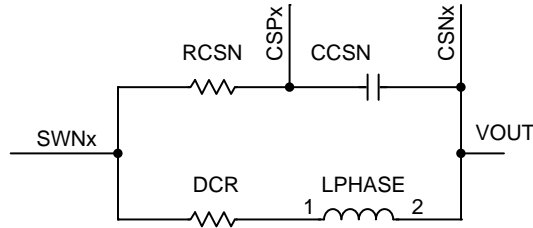

Figure 8.

**Two-Phase Rail Total Current Sense Amplifier**

The NCP81246 uses a patented approach to sum the phase currents into a single temperature compensated total current signal. This signal is then used to generate the output voltage droop, total current limit, and the output current monitoring functions. The total current signal is floating with respect to CSREF. The current signal is the difference between CSCOMP and CSREF. The Rref(n) resistors sum the signals

from the output side of the inductors to create a low impedance virtual ground. The amplifier actively filters and gains up the voltage applied across the inductors to recover the voltage drop across the inductor series resistance (DCR). Rth is placed near an inductor to sense the temperature of the inductor. This allows the filter time constant and gain to be a function of the Rth NTC resistor and compensate for the change in the DCR with temperature.

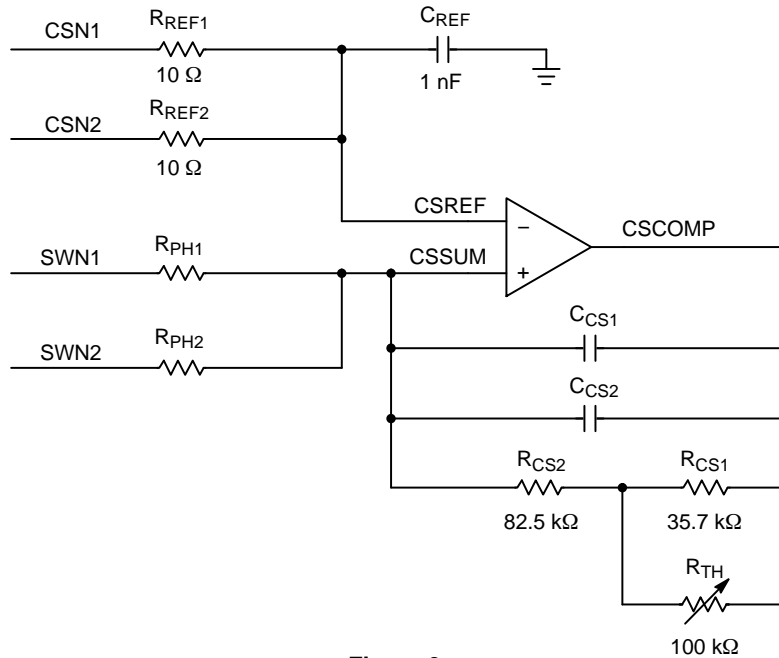

Figure 9.

The DC gain equation for the current sensing:

$$V_{CSCOMP-CSREF} = - \frac{R_{CS2} + \frac{R_{CS1} \cdot R_{TH}}{R_{CS1} + R_{TH}}}{R_{PH}} \cdot (I_{OUT\_Total} \cdot DCR) \quad (\text{eq. 3})$$

Set the gain by adjusting the value of the  $R_{PH}$  resistors. The DC gain should be set to the output voltage droop. If the voltage from CSCOMP to CSREF is less than 100 mV at ICCMAX then it is recommend increasing the gain of the CSCOMP amp. This is required to provide a good current signal to offset voltage ratio for the ILIMIT pin. When no droop is needed, the gain of the amplifier should be set to provide ~100 mV across the current limit programming resistor at full load. The NTC should be placed near the closest inductor. The output voltage droop should be set with the droop filter divider.

The pole frequency in the CSCOMP filter should be set equal to the zero from the output inductor. This allows the circuit to recover the inductor DCR voltage drop current signal.  $C_{CS1}$  and  $C_{CS2}$  are in parallel to allow for fine tuning of the time constant using commonly available values. It is best to fine tune this filter during transient testing.

$$F_z = \frac{DCR @ 25^\circ C}{2 \cdot \pi \cdot L_{Phase}} \quad (eq. 4)$$

### Two-Phase Rail Programming the Current Limit

The current limit thresholds are programmed with a resistor between the ILIMIT and CSCOMP pins. The ILIMIT pin mirrors the voltage at the CSREF pin and mirrors the sink current internally to IOUT (reduced by the IOUT Current Gain) and the current limit comparators. The 100% current limit trips if the ILIMIT sink current exceeds 10  $\mu$ A for 50  $\mu$ s. The 150% current limit trips with minimal delay if the ILIMIT sink current exceeds 15  $\mu$ A. Set the value of the current limit resistor based on the CSCOMP-CSREF voltage as shown below.

$$R_{LIMIT} = \frac{\frac{R_{CS2} + \frac{R_{CS1} \cdot R_{TH}}{R_{CS1} + R_{TH}}}{R_{PH}} \cdot (I_{OUT_{Total}} \cdot DCR)}{10 \mu} \quad (eq. 5)$$

or

$$R_{LIMIT} = \frac{V_{CSCOMP - CSREF @ I_{LIMIT}}}{10 \mu} \quad (eq. 6)$$

### Two-Phase Rail Programming DAC Feed-Forward Filter

The DAC feed-forward implementation is realized by having a filter on the VSN pin. Programming  $R_{VSN}$  sets the gain of the DAC feed-forward and  $C_{VSN}$  provides the time constant to cancel the time constant of the system per the following equations.  $C_{OUT}$  is the total output capacitance and  $R_{OUT}$  is the output impedance of the system.

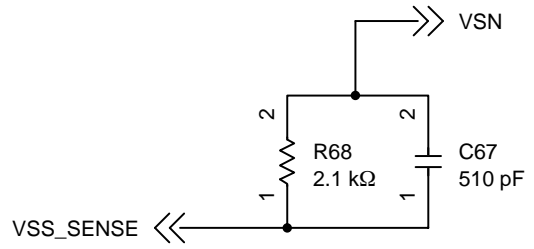

Figure 10.

$$R_{VSN} = C_{OUT} \cdot R_{OUT} \cdot 453.6 \cdot 10^6 \quad (eq. 7)$$

$$C_{VSN} = \frac{R_{OUT} \cdot C_{OUT}}{R_{VSN}} \quad (eq. 8)$$

### Two-Phase Rail Programming DROOP

The signals CSCOMP and CSREF are differentially summed with the output voltage feedback to add precision voltage droop to the output voltage.

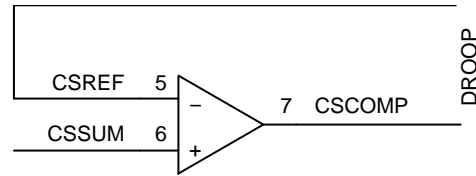

Figure 11.

$$Droop = DCR \cdot \frac{R_{CS}}{R_{PH}} \quad (eq. 9)$$

### Two-Phase Rail Programming IOUT

The IOUT pin sources a current in proportion to the ILIMIT sink current. The voltage on the IOUT pin is monitored by the internal A/D converter and should be scaled with an external resistor to ground such that a load equal to ICC\_MAX generates a 2 V signal on IOUT. A pull-up resistor from 5 V VCC can be used to offset the IOUT signal positive if needed.

$$R_{IOUT} = \frac{2.0 V \cdot R_{LIMIT}}{10 \cdot \frac{R_{CS2} + \frac{R_{CS1} \cdot R_{TH}}{R_{CS1} + R_{TH}}}{R_{PH}} \cdot (I_{OUT_{ICC\_MAX}} \cdot DCR)} \quad (eq. 10)$$

# NCP81246

## Programming ICC\_MAX

A resistor to ground on the IMAX pin programs these registers at the time the part is enabled. 10 μA is sourced from these pins to generate a voltage on the program resistor. The resistor value should be no less than 2 kΩ.

**Design Note:** Since ICC\_MAX is multi-functioned with LG, it is crucial that the LS FET is not turned on during ICC\_MAX programming. Source current and maximum

resistor value must not produce a voltage at the FET gate that will turn it on. Keeping the voltage less than 400 mV should be safe.

## IccMax\_2ph:

$$R_{IccMax2ph} = \frac{IccMax_{2ph} + 32}{127} \cdot 200 \text{ k}\Omega \quad (\text{eq. 11})$$

**IccMax\_1ph:** See Table 10 below.

**Table 10. ICCMAX\_1PH**

Resistor	00h (IA)	Resistor	Other 02h/03h
6.8 kΩ	23	5 kΩ	3
11 kΩ	24	7.8 kΩ	4
14.1 kΩ	25	11 kΩ	5
17.2 kΩ	28	14.1 kΩ	6
22.6 kΩ	29	17.2 kΩ	7
26.5 kΩ	30	20.3 kΩ	8
29.5 kΩ	34	23.4 Ω	9
32.8 kΩ	35		
36 kΩ	36		

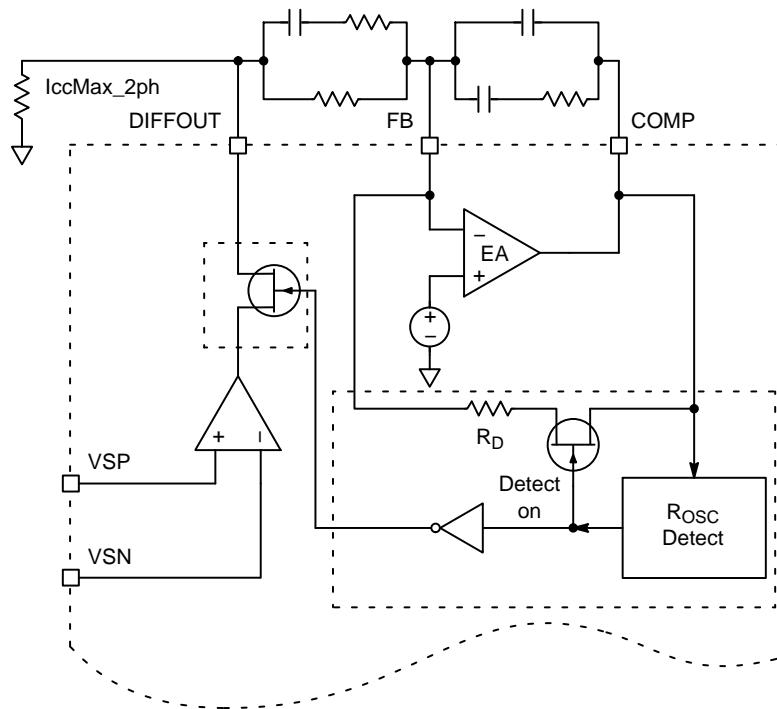

**Figure 12.**

**Programming TSENSE**

Temperature sense inputs are provided. A precision current is sourced out the output of the TSENSE pin to generate a voltage on the temperature sense network. The voltage on the temperature sense input is sampled by the

internal A/D converter. A 100 k NTC similar to the VISHAY ERT–J1VS104JA should be used. See the specification table for the thermal sensing voltage thresholds and source current.

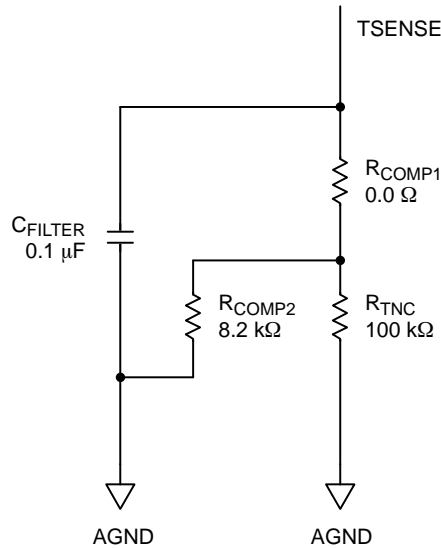

Figure 13.

**Precision Oscillator**

A programmable precision oscillator is provided. The clock oscillator serves as the master clock to the ramp generator circuit. This oscillator is programmed during start-up by a resistor to ground on the LG1/ROSC pin.

The oscillator generates triangle ramps that are 0.5~2.5 V in amplitude depending on the VRMP pin voltage to provide input voltage feed forward compensation.

feed-forward control by varying the ramp magnitude with respect to the VRMP pin voltage. The VRMP pin also has a UVLO function. The VRMP UVLO is only active after the controller is enabled. The VRMP pin is high impedance input when the controller is disabled.

The PWM ramp is changed according to the following,

$$V_{RAMPpk=pkpp} = 0.1 \cdot V_{VRMP} \quad (\text{eq. 12})$$

**Programming the Ramp Feed-Forward Circuit**

The ramp generator circuit provides the ramp used by the PWM comparators. The ramp generator provides voltage

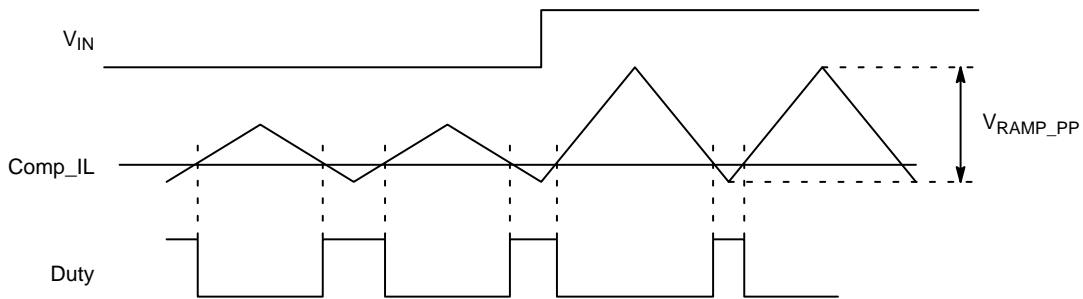

Figure 14.

**Two-Phase Rail PWM Comparators**

The non-inverting input of the comparator for each phase is connected to the summed output of the error amplifier (COMP) and each phase current ( $I_L \cdot DCR \cdot \text{Phase Balance}$

Gain Factor). The inverting input is connected to the oscillator ramp voltage with a 1.3 V offset. The operating input voltage range of the comparators is from 0 V to 3.0 V and the output of the comparator generates the PWM output.

During steady state operation, the duty cycle is centered on the valley of the sawtooth ramp waveform. The steady state duty cycle is still calculated by approximately  $V_{OUT}/V_{IN}$ .

**Two-Phase Rail Phase Detection Sequence**

During start-up, the number of operational phases and their phase relationship is determined by the internal circuitry monitoring the CSP outputs. Normally, this rail operates as a two-phase VCCGT PWM controller. If CSP2\_2ph is pulled high to VCC, the two-phase rail operates as a single-phase rail.

**Disable Single-Phase Rail**

If the NCP81246 is to provide fewer than three rails, one or both of the single-phase rails can be disabled by pulling up their respective CSP pin. The main rail cannot be disabled.

**Single-Phase Rails**

The architecture of the two single-phase rails makes use of a digitally enhanced, high performance, current mode RPM control method that provides excellent transient response while minimizing transient aliasing. The average operating frequency is digitally stabilized to remove

frequency drift under all continuous mode operating conditions. At light load the single-phase rails automatically transition into DCM operation to save power.

**Single-Phase Rail Remote Sense Error Amplifier**

A high performance, high input impedance, true differential transconductance amplifier is provided to accurately sense the regulator output voltage and provide high bandwidth transient performance. The VSP and VSN inputs should be connected to the regulator’s output voltage sense points through filter networks describe in the Droop Compensation and DAC Feedforward Compensation sections. The remote sense error amplifier outputs a current proportional to the difference between the output voltage and the DAC voltage:

$$I_{COMP} = gm \cdot (V_{DAC} - (V_{VSP} - V_{VSN})) \quad (eq. 13)$$

This current is applied to a standard Type II compensation network.

**Single-Phase Rail Voltage Compensation**

The Remote Sense Amplifier outputs a current that is applied to a Type II compensation network formed by external tuning components CLF, RZ and CHF.

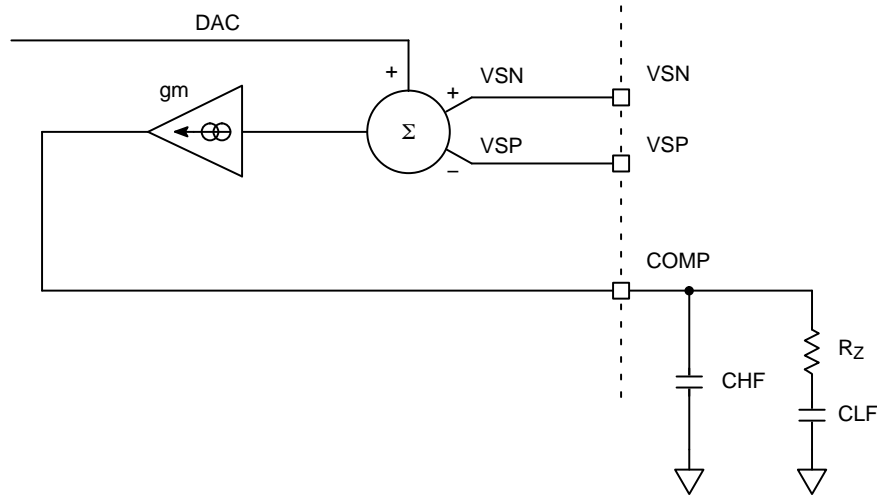

Figure 15.

**Single-Phase Rail – Differential Current Feedback Amplifier**

Each single-phase controller has a low offset, differential amplifier to sense output inductor current. An external lowpass filter can be used to superimpose a reconstruction of the AC inductor current onto the DC current signal sensed across the inductor. The lowpass filter time constant should match the inductor L/DCR time constant by setting the filter pole frequency equal to the zero of the output inductor. This makes the filter AC output mimic the product of AC inductor current and DCR, with the same gain as the filter DC output. It is best to perform fine tuning of the filter pole during transient testing.

$$F_Z = \frac{DCR @ 25^{\circ}C}{2 \cdot \pi \cdot L_{Phase}} \quad (eq. 14)$$

$$F_P = \frac{1}{2 \cdot \pi \cdot \left( \frac{R_{PHSP} \cdot (R_{TH} + R_{CSSP})}{R_{PHSP} + R_{TH} + R_{CSSP}} \right) \cdot C_{CSSP}} \quad (eq. 15)$$

Forming the lowpass filter with an NTC thermistor ( $R_{TH}$ ) placed near the output inductor, compensates both the DC gain and the filter time constant for the inductor DCR change with temperature. The values of  $R_{PHSP}$  and  $R_{CSSP}$  are set

# NCP81246

based on the effect of temperature on both the thermistor and inductor. The CSP and CSN pins are high impedance inputs, but it is recommended that the lowpass filter resistance not exceed 10 kΩ in order to avoid offset due to leakage current. It is also recommended that the voltage sense element (inductor DCR) be no less than 0.5 mΩ for sufficient current accuracy. Recommended values for the external filter components are:

$$R_{PHSP} = 7.68 \text{ k}\Omega$$

$$R_{CSSP} = 14.3 \text{ k}\Omega$$

$$R_{TH} = 100 \text{ k}\Omega, \text{ Beta} = 4300$$

$$C_{CSSP} = \frac{L_{PHASE}}{\frac{R_{PHSP} \cdot (R_{TH} + R_{CSSP})}{R_{PHSP} + R_{TH} + R_{CSSP}} \cdot DCR} \quad (\text{eq. 16})$$

Using 2 parallel capacitors in the lowpass filter allows fine tuning of the pole frequency using commonly available capacitor values.

The DC gain equation for the current sense amplifier output is:

$$V_{CURR} = \frac{R_{TH} + R_{CSSP}}{R_{PHSP} + R_{TH} + R_{CSSP}} \cdot I_{OUT} \cdot DCR \quad (\text{eq. 17})$$

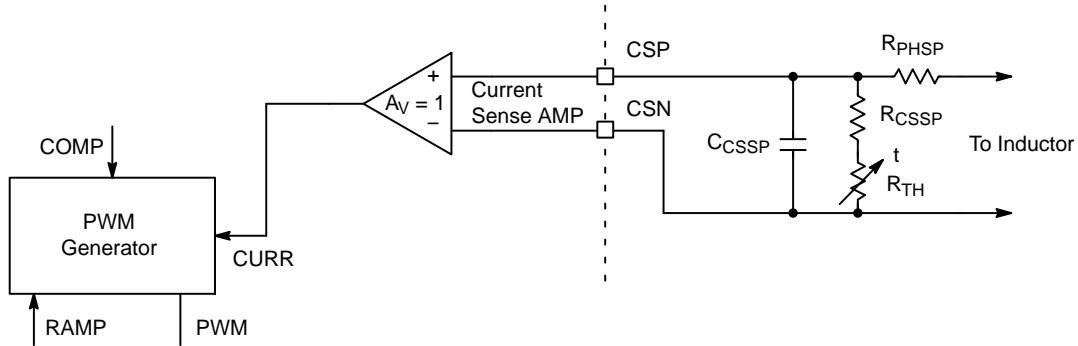

Figure 16.

The amplifier output signal is combined with the COMP and RAMP signals at the PWM comparator inputs to produce the Ramp Pulse Modulation (RPM) PWM signal.

### Single-Phase Rail – Loadline Programming (DROOP)

An output loadline is a power supply characteristic wherein the regulated (DC) output voltage decreases by a voltage  $V_{DROOP}$  proportional to load current. This characteristic can reduce the output capacitance required to

maintain output voltage within limits during load transients faster than those to which the regulation loop can respond. In the NCP81246, a loadline is produced by adding a signal proportional to output load current ( $V_{DROOP}$ ) to the output voltage feedback signal – thereby satisfying the voltage regulator at an output voltage reduced proportional to load current.  $V_{DROOP}$  is developed across a resistance between the VSP pin and the output voltage sense point.

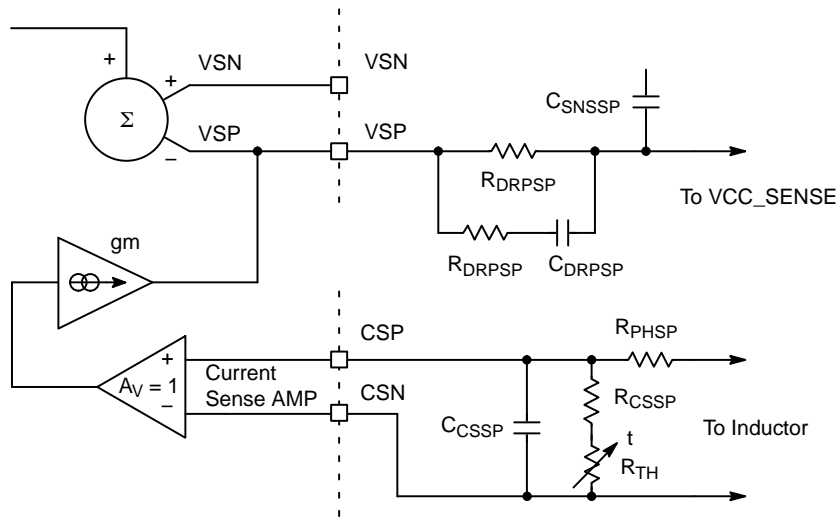

Figure 17.

$$V_{DROOP} = R_{DRPSP} \cdot gm \cdot \frac{R_{TH} + R_{CSSP}}{R_{PHSP} + R_{TH} + R_{CSSP}} \cdot I_{OUT} \cdot DCR \quad (\text{eq. 18})$$

The loadline is programmed by choosing  $R_{DRPSP}$  such that the ratio of voltage produced across  $R_{DRPSP}$  to output current is equal to the desired loadline.

$$R_{DRPSP} = \frac{\text{Loadline}}{gm \cdot DCR} \cdot \frac{R_{PHSP} + R_{TH} + R_{CSSP}}{R_{TH} + R_{CSSP}} \quad (\text{eq. 19})$$

**Single-Phase Rail – Programming the DAC Feed-Forward Filter**

The DAC feed-forward implementation for the single-phase rail is the same as for the 2-phase rail. The NCP81246 outputs a pulse of current from the VSN pin

upon each increment of the internal DAC following a DVID UP command. A parallel RC network inserted into the path from VSN to the output voltage return sense point, VSS\_SENSE, causes these current pulses to temporarily decrease the voltage between VSP and VSN. This causes the output voltage during DVID to be regulated slightly higher, in order to compensate for the response of the Droop function to the inductor current flowing into the charging output capacitors.  $R_{FFSP}$  sets the gain of the DAC feed-forward and  $C_{FFSP}$  provides the time constant to cancel the time constant of the system per the following equations.  $C_{OUT}$  is the total output capacitance of the system.

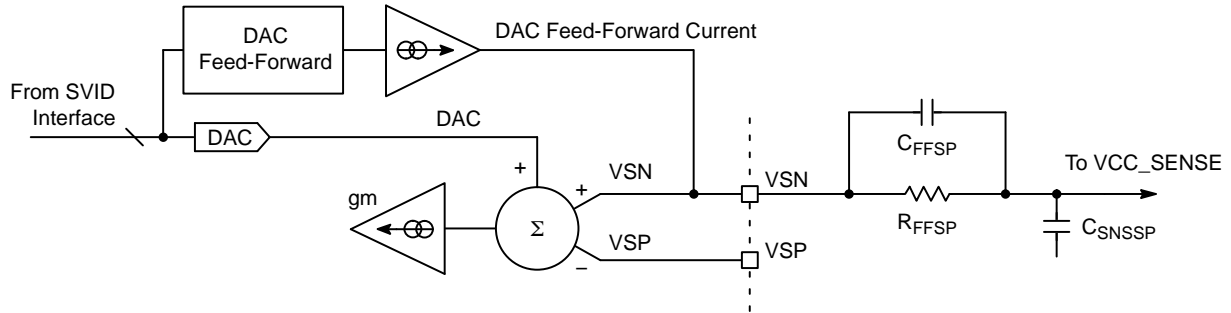

Figure 18.

$$R_{FFSP} = \frac{\text{Loadline} \cdot C_{OUT}}{1.35 \cdot 10^{-9}} \quad (\Omega) \qquad C_{FFSP} = \frac{200}{R_{FFSP}} \quad (\text{nF}) \qquad (\text{eq. 20})$$

**Single-Phase Rail – Programming the Current Limit**

The current limit threshold is programmed with a resistor ( $R_{ILIMSP}$ ) from the ILIM pin to ground. The current limit latches the single-phase rail off immediately if the ILIM pin voltage exceeds the ILIM Threshold. Set the value of the

current limit resistor based on the equation shown below. A capacitor must be placed in parallel with the programming resistor to avoid false trips due to the effect of the output ripple current.

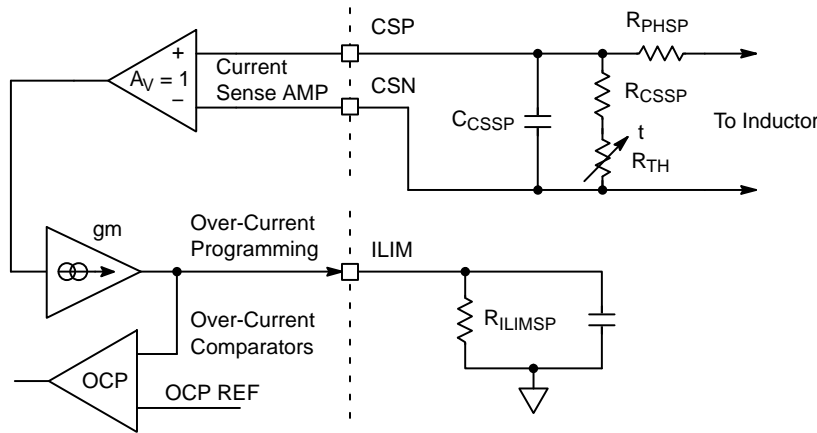

Figure 19.

$$R_{ILIMSP} = \frac{1.3 \text{ V}}{gm \cdot \frac{R_{TH} + R_{CSSP}}{R_{PHSP} + R_{TH} + R_{CSSP}} \cdot I_{OUT\_LIMIT} \cdot DCR} \quad (\text{eq. 21})$$

**Single-Phase Rail – Programming IOU**

The IOU pin sources a current in proportion to the ILIMIT sink current. The voltage on the IOU pin is monitored by the internal A/D converter and should be

scaled with an external resistor to ground such that a load equal to ICCMAX generates a 2 V signal on IOU. A pull-up resistor from 5 V VCC can be used to offset the IOU signal positive if needed.

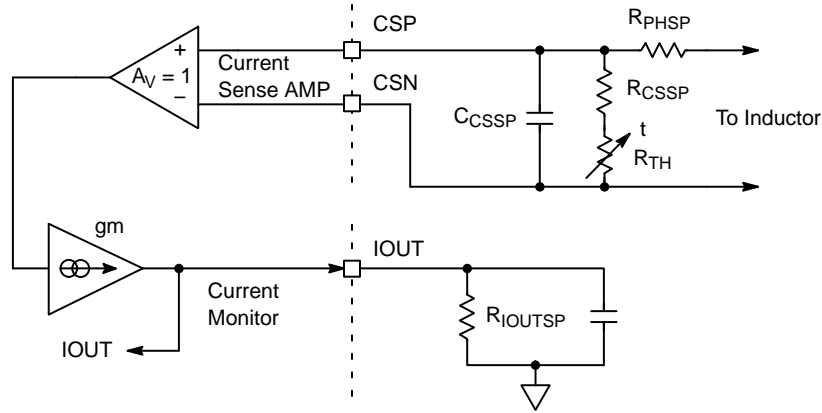

**Figure 20.**

$$R_{IOUTSP} = \frac{2\text{ V}}{gm \cdot \frac{R_{TH} + R_{CSSP}}{R_{PHSP} + R_{TH} + R_{CSSP}} \cdot I_{ccMax} \cdot DCR} \tag{eq. 22}$$

**Single-Phase Rail PWM Comparators**

The non-inverting input of each comparator (one for each phase) is connected to the summation of the output of the error amplifier (COMP) and each phase current (IL · DCR · Phase Current Gain Factor). The inverting input is connected to the triangle ramp voltage of that phase. The output of the comparator generates the PWM output.

A PWM pulse starts when the error amp signal (COMP voltage) rises above the trigger threshold plus gained-up

inductor current, and stops when the artificial ramp plus gained-up inductor current crosses the COMP voltage. Both edges of the PWM signals are modulated. During a transient event, the duty cycle can increase rapidly as the COMP voltage increases with respect to the ramps, to provide a highly linear and proportional response to the step load.



PROTECTION FEATURES

**Under Voltage Lockouts**

There are several under voltage monitors in the system. Hysteresis is incorporated within the comparators. The NCP81246 monitors the 5 V VCC supply as well as the VRMP pin. The gate drivers monitor both the gate driver VCC and the BST voltage. When the voltage on the gate

driver is insufficient it will pull DRON low and prevents the controller from being enabled. The gate driver will hold DRON low for a minimum period of time to allow the controller to hold off its start-up sequence. In this case the PWM is set to the MID state to begin soft start.

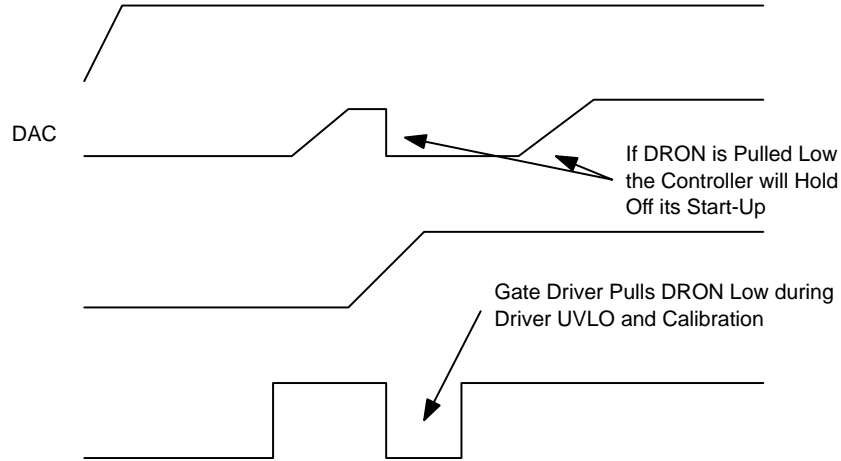

Figure 21. Gate Driver UVLO Restart

**Soft Start**

Soft start is implemented internally. A digital counter steps the DAC up from zero to the target voltage based on the predetermined SetVID\_SLOW rate in the spec table. The PWM signal will start out open with a test current to collect data on SVID address and  $V_{BOOT}$ . After the configuration data is collected, if the controller is enabled,

the internal and external PWMs will be set to 2.0 V MID state to indicate that the drivers should be in diode mode. DRON will then be asserted. As the DAC ramps the PWM outputs will begin to fire. Each phase will move out of the MID state when the first PWM pulse is produced. When a controller is disabled the PWM signal will return to the MID state.

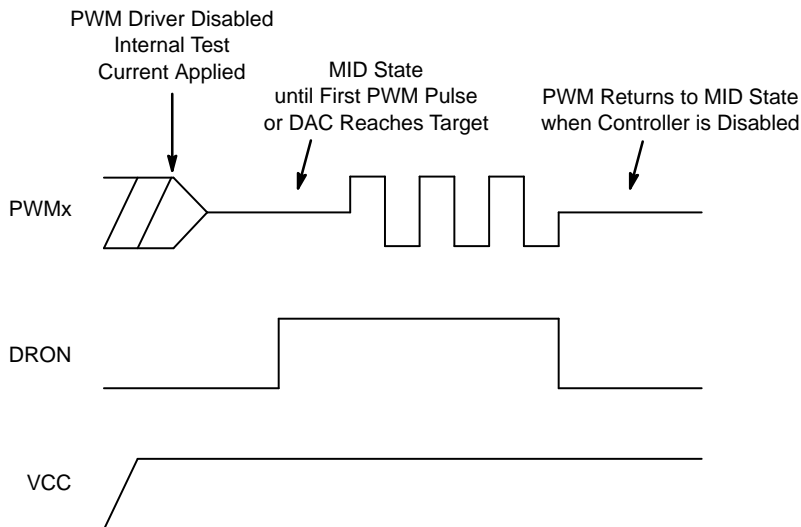

Figure 22. Soft Start

**Over Current Latch-Off Protection**

Each of the NCP81246 rails compares a programmable current-limit set point to the voltage from the output of its current-summing amplifier. The level of current limit is set with the resistor from the ILIM pin to CSCOMP (two-phase) or to ground (single-phase rails).

**Two-Phase Rail Over Current**

The current through the external resistor connected between ILIM and CSCOMP is then compared to the internal current-limit threshold. If the current generated through this resistor into the ILIM pin ( $I_{LIM}$ ) exceeds the internal current-limit threshold, an internal latch-off counter starts, and the controller shuts down if the fault is not removed after 50  $\mu$ s (immediately shut down for 150% of current-limit threshold) after which the outputs will remain disabled until the  $V_{CC}$  voltage or EN is toggled.

The voltage swing of CSCOMP cannot go below ground. This limits the voltage drop across the DCR through the current balance circuitry. An inherent per-phase current limit protects individual phases if one or more phases stop functioning because of a faulty component. The over-current limit is programmed by a resistor on the ILIM pin. The resistor value can be calculated by the following equations.

Equation related to the NCP81246:

$$R_{ILIM} = \frac{I_{LIM} \cdot DCR \cdot \frac{R_{CS}}{R_{PH}}}{I_{CL}} \quad (\text{eq. 23})$$

Where  $I_{CL} = 10 \mu\text{A}$

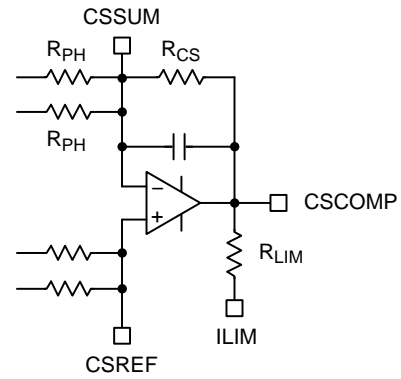

Figure 23.

**Under Voltage Monitor**

The output voltage is monitored at the output of the differential amplifier for UVLO. If the output falls more than 300 mV below the DAC–DROOP voltage the UVLO comparator will trip sending the VR\_RDY signal low.

**Over Voltage Protection**

The output voltage is also monitored at the output of the differential amplifier for OVP. During normal operation, if the output voltage exceeds the DAC voltage by 400 mV, the VR\_RDY flag goes low, and the output voltage will be ramped down to 0 V. At the same time, the high side gate drivers are all turned off and the low side gate drivers are all turned on. The part will stay in this mode until the  $V_{CC}$  voltage or EN is toggled.

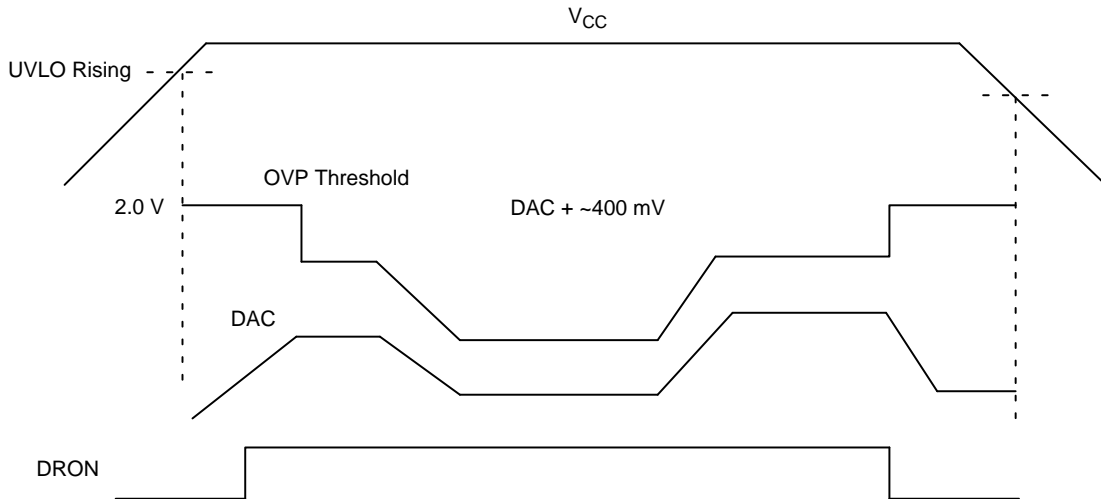
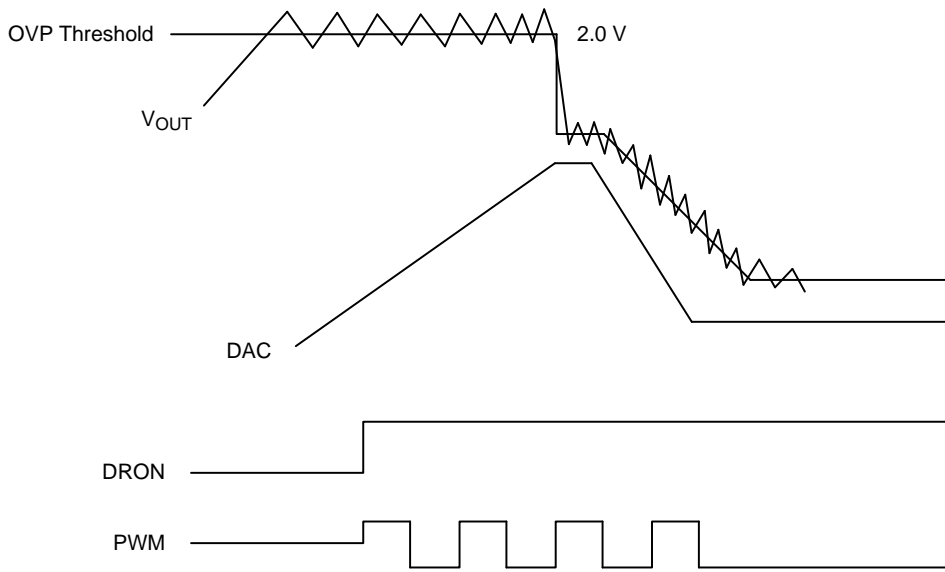
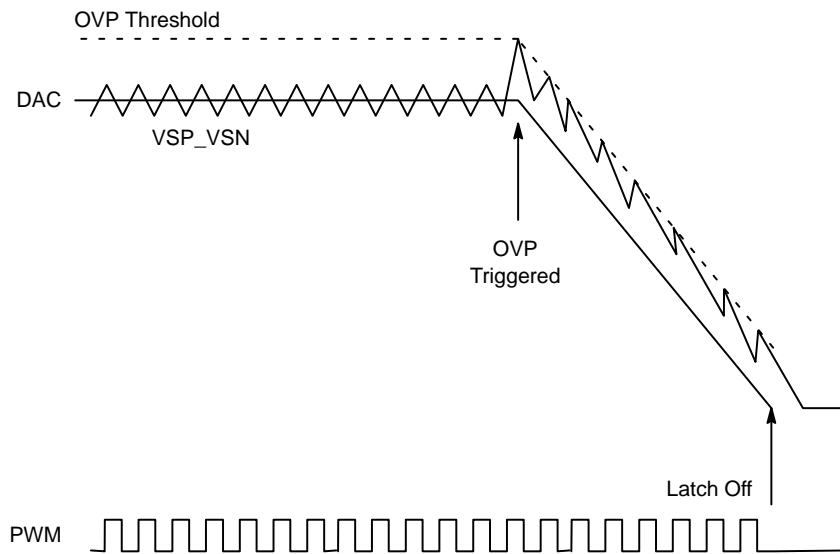

Figure 24. OVP Threshold Behavior

# NCP81246



**Figure 25. OVP Behavior at Start-Up**



**Figure 26. OVP during Normal Operation Mode**

During start-up, the OVP threshold is set to 2.0 V. This allows the controller to start up without false triggering the OVP.

# NCP81246

## PACKAGE DIMENSIONS

QFN52 6x6, 0.4P  
CASE 485BE  
ISSUE B

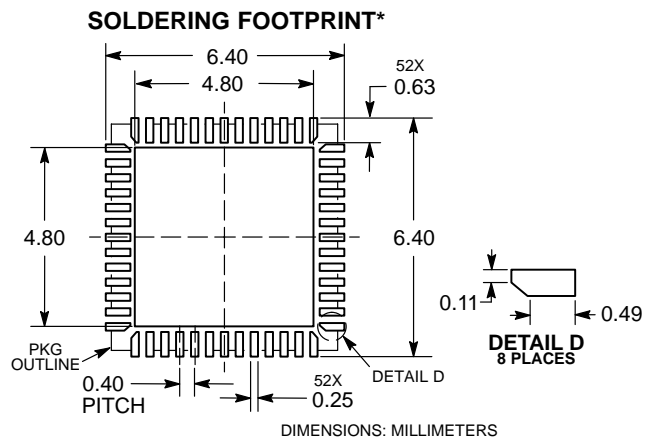
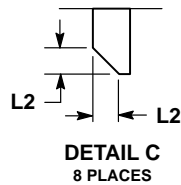
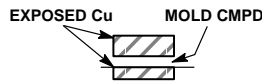
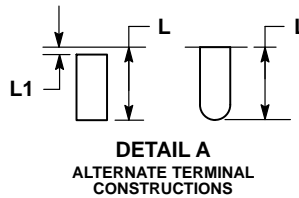
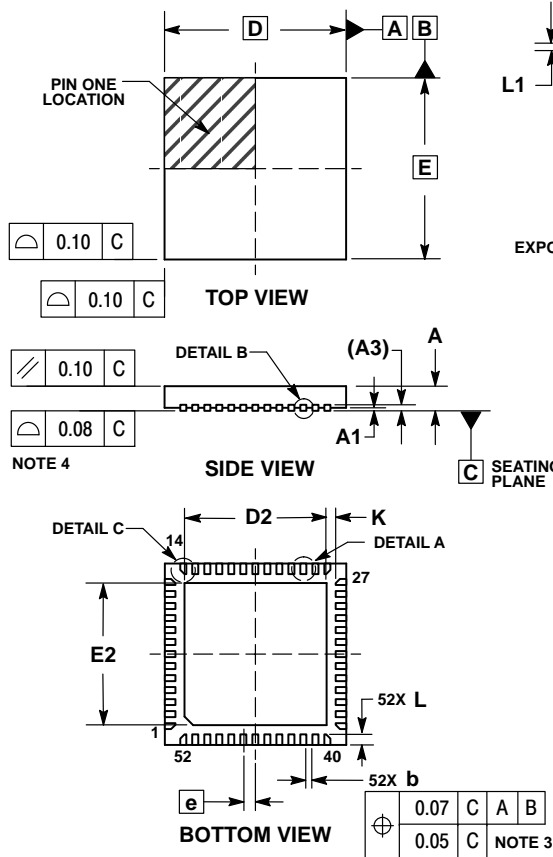

**NOTES:**

1. DIMENSIONING AND TOLERANCING PER ASME Y14.5M, 1994.
2. CONTROLLING DIMENSIONS: MILLIMETERS.
3. DIMENSION b APPLIES TO PLATED TERMINAL AND IS MEASURED BETWEEN 0.15 AND 0.30mm FROM TERMINAL TIP
4. COPLANARITY APPLIES TO THE EXPOSED PAD AS WELL AS THE TERMINALS.

DIM	MILLIMETERS	
	MIN	MAX
A	0.80	1.00
A1	0.00	0.05
A3	0.20 REF	
b	0.15	0.25
D	6.00 BSC	
D2	4.60	4.80
E	6.00 BSC	
E2	4.60	4.80
e	0.40 BSC	
K	0.30 REF	
L	0.25	0.45
L1	0.00	0.15
L2	0.15 REF	

\*For additional information on our Pb-Free strategy and soldering details, please download the ON Semiconductor Soldering and Mounting Techniques Reference Manual, SOLDERRM/D.

Intel is a registered trademark of Intel Corporation in the U.S. and/or other countries.

ON Semiconductor and the are registered trademarks of Semiconductor Components Industries, LLC (SCILLC) or its subsidiaries in the United States and/or other countries. SCILLC owns the rights to a number of patents, trademarks, copyrights, trade secrets, and other intellectual property. A listing of SCILLC's product/patent coverage may be accessed at [www.onsemi.com/site/pdf/Patent-Marketing.pdf](http://www.onsemi.com/site/pdf/Patent-Marketing.pdf). SCILLC reserves the right to make changes without further notice to any products herein. SCILLC makes no warranty, representation or guarantee regarding the suitability of its products for any particular purpose, nor does SCILLC assume any liability arising out of the application or use of any product or circuit, and specifically disclaims any and all liability, including without limitation special, consequential or incidental damages. "Typical" parameters which may be provided in SCILLC data sheets and/or specifications can and do vary in different applications and actual performance may vary over time. All operating parameters, including "Typicals" must be validated for each customer application by customer's technical experts. SCILLC does not convey any license under its patent rights nor the rights of others. SCILLC products are not designed, intended, or authorized for use as components in systems intended for surgical implant into the body, or other applications intended to support or sustain life, or for any other application in which the failure of the SCILLC product could create a situation where personal injury or death may occur. Should Buyer purchase or use SCILLC products for any such unintended or unauthorized application, Buyer shall indemnify and hold SCILLC and its officers, employees, subsidiaries, affiliates, and distributors harmless against all claims, costs, damages, and expenses, and reasonable attorney fees arising out of, directly or indirectly, any claim of personal injury or death associated with such unintended or unauthorized use, even if such claim alleges that SCILLC was negligent regarding the design or manufacture of the part. SCILLC is an Equal Opportunity/Affirmative Action Employer. This literature is subject to all applicable copyright laws and is not for resale in any manner.

### PUBLICATION ORDERING INFORMATION

**LITERATURE FULFILLMENT:**  
Literature Distribution Center for ON Semiconductor  
19521 E. 32nd Pkwy, Aurora, Colorado 80011 USA  
Phone: 303-675-2175 or 800-344-3860 Toll Free USA/Canada  
Fax: 303-675-2176 or 800-344-3867 Toll Free USA/Canada  
Email: [orderlit@onsemi.com](mailto:orderlit@onsemi.com)

**N. American Technical Support:** 800-282-9855 Toll Free  
USA/Canada  
**Europe, Middle East and Africa Technical Support:**  
Phone: 421 33 790 2910  
**Japan Customer Focus Center**  
Phone: 81-3-5817-1050

**ON Semiconductor Website:** [www.onsemi.com](http://www.onsemi.com)  
**Order Literature:** <http://www.onsemi.com/orderlit>  
For additional information, please contact your local Sales Representative