

AWB519 Data Sheet

5 ~ 1200 MHz Wide-band CATV Linear Amplifier MMIC

1. Product Overview

1.1 General Description

AWB519, a wide-band linear amplifier MMIC, has high linearity and low noise over a wide range of frequency from 5 MHz to 1200 MHz, being suitable for use in the fiber receiver, distribution amplifiers and drop amplifiers of CATV. The amplifier is available in an SOT89 package and passes through the stringent 100% DC & RF test via an automated test handler.

1.2 Features

- 5 ~ 1200 MHz Bandwidth
- 20.4 dB Gain at 500 MHz
- Output Power: 99 dB μ V
- 2.6 dB NF at 500MHz
- Robust under Hard Operating Conditions
- +8 V, 135 mA Supply

1.3 Applications

- CATV forward at 50 ~ 1200 MHz
- CATV reverse at 5 ~ 300 MHz
- Optical Node, FTTH, RFoG

1.4 Package Profile & RoHS Compliance

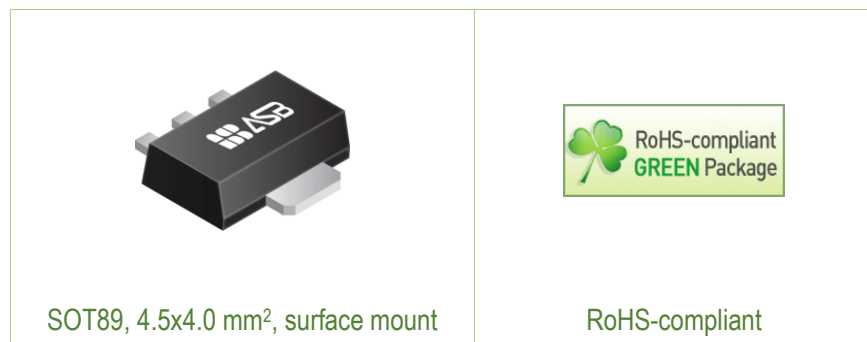

2. Summary on Product Performances

2.1 Typical Performance

Supply voltage = +8 V, T_A = +25 °C, Z_O = 75 Ω.

Parameter	Reverse			Forward			Unit
	5	50	300	50	500	1000	
Frequency	5	50	300	50	500	1000	MHz
Noise Figure	-	2.5	2.7	2.5	2.6	2.5	dB
Gain	20.9	21.1	20.3	21.0	20.4	18.9	dB
S11	-20.5	-25.0	-16.0	-17.0	-16.0	-18.0	dB
S22	-20.0	-27.0	-14.5	-17.5	-20.0	-16.0	dB
CSO ¹⁾	-			61			dBc
CTB ¹⁾	-			73			dBc
Current	135						mA
Device Voltage	+8						V

1) P_{out} = 99 dBμV for CENELEC-42.

2.2 Product Specification

Supply voltage = +8 V, T_A = +25 °C, Z_O = 75 Ω.

Parameter	Min	Typ	Max	Unit
Frequency		500		MHz
Noise Figure		2.6	2.9	dB
Gain	19.4	20.4		dB
S11	-13	-16.0		dB
S22	-17	-20.0		dB
Current	115	135	155	mA
Device Voltage		+8		V

2.3 Pin Configuration

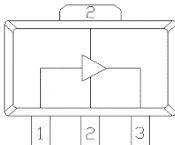
Pin	Description	Simplified Outline
1	RF_IN	
2	Ground	
3	RF_OUT & Bias	

2.4 Absolute Maximum Ratings

Parameters	Max. Ratings
Operation Case Temperature	-40 to +85 °C
Storage Temperature	-40 to +150 °C
Device Voltage	+9 V
Maximum Current	235 mA
Operation Junction Temperature	+150 °C
Input RF Power (CW, 75 Ω matched)	+25 dBm

2.5 Thermal Resistance

Symbol	Description	Typ	Unit
R _{th}	Thermal resistance from junction to lead	42	°C/W

2.6 ESD Classification & Moisture Sensitivity Level

ESD Classification

HBM	Class 1B	Voltage Level: 750 V
MM	Class A	Voltage Level: 100 V

CAUTION: Gallium Arsenide Integrated Circuits are sensitive to electrostatic discharge (ESD) and can be damaged by static electricity. Proper ESD control techniques should be used when handling these devices.

Moisture Sensitivity Level

MSL 3 at 260 °C reflow

(Intentionally Blanked)

3. Application: 50 ~ 1000 MHz (CATV forward, $V_{supply} = +8 V$)

3.1 Application Circuit & Evaluation Board

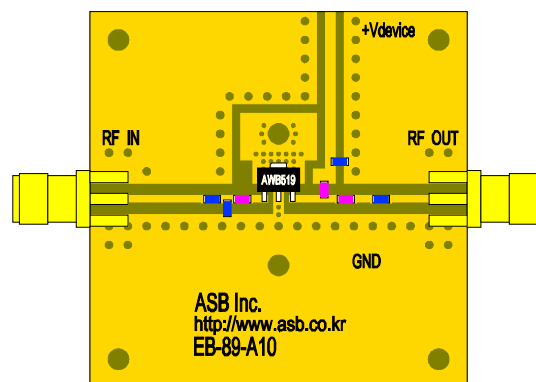
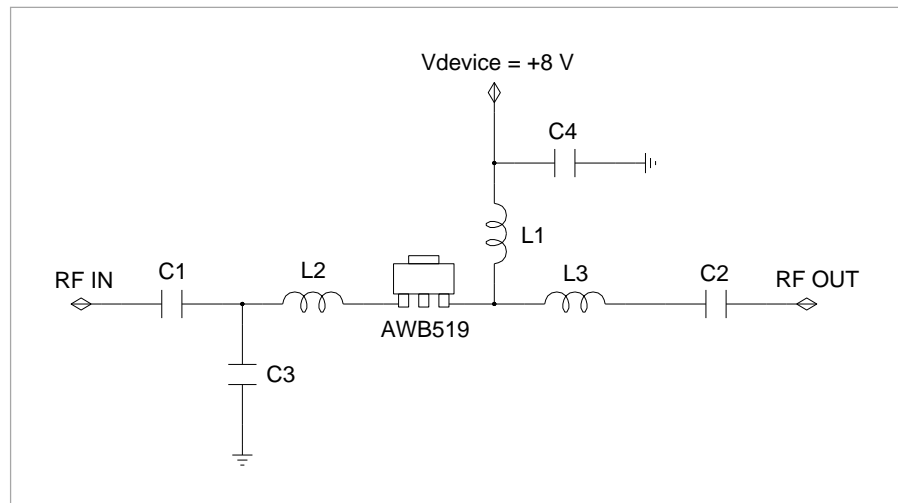

PCB Information	
Material	FR4
Thickness (mm)	0.8
Size (mm)	40x40
EB No.	EB-89-A10

Bill of Material

Symbol	Value	Size	Description	Manufacturer
AWB519	-	-	MMIC Amplifier	ASB
C1, C2	1 μ F	0603	DC blocking capacitor	Murata
C3	1.2 pF	0603	Matching capacitor	Murata
C4	10 μ F	0805	Decoupling capacitor	Murata
L1	1 μ H	1206	RF choke inductor	Murata
L2	10 nH	0603	Matching inductor	Murata
L3	5.6 nH	0603	Matching inductor	Murata

3.2 Performance Table

Supply voltage = +8 V, $T_A = +25\text{ }^\circ\text{C}$, $Z_0 = 75\ \Omega$.

Parameter	Forward				Unit
Frequency	50	500	860	1000	MHz
Noise Figure	2.5	2.6	2.6	2.5	dB
Gain	21.0	20.4	19.7	18.9	dB
S11	-17.0	-16.0	-19.0	-18.0	dB
S22	-17.5	-20.0	-17.0	-16.0	dB
CSO ¹⁾	61				dBc
CTB ¹⁾	73				dBc
Current	135				mA
Device Voltage	+8				V

1) $P_{out} = 99\text{ dB}\mu\text{V}$ for CENELEC-42.

3.3 Plot of S-parameter & Stability Factor

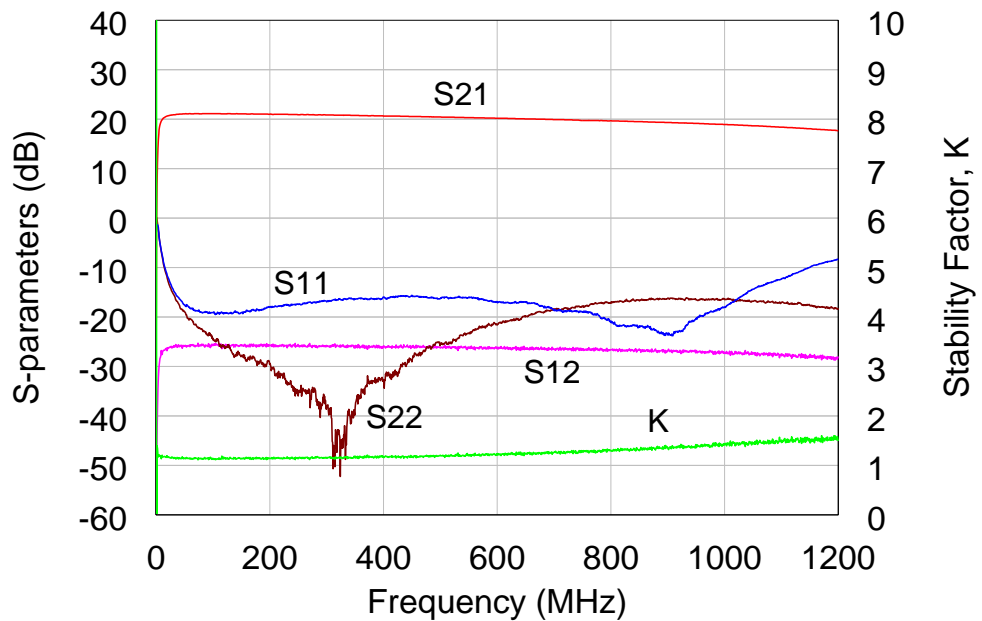

3.4 Plots of Noise Figure and Performances with Temperature

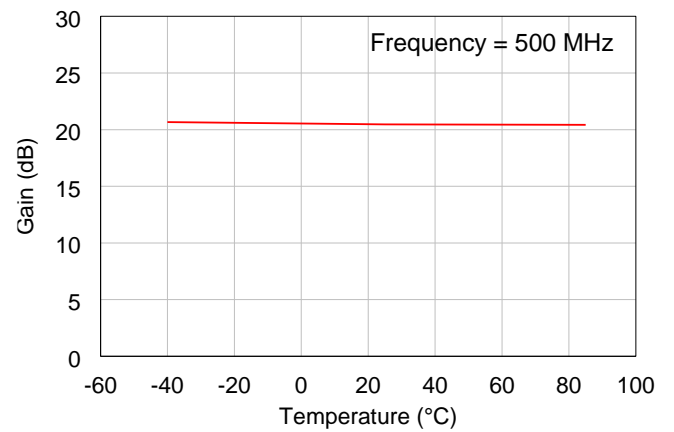
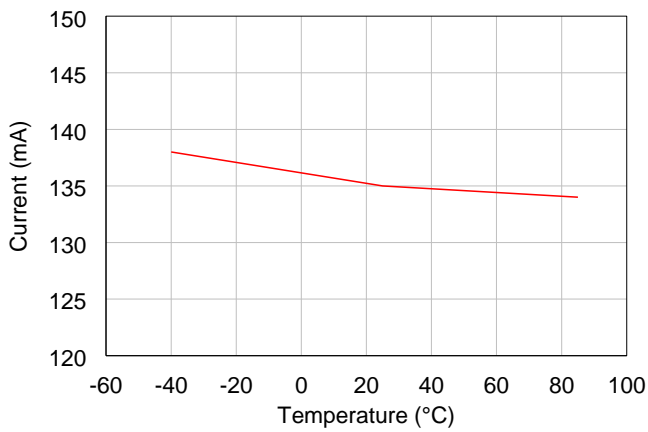
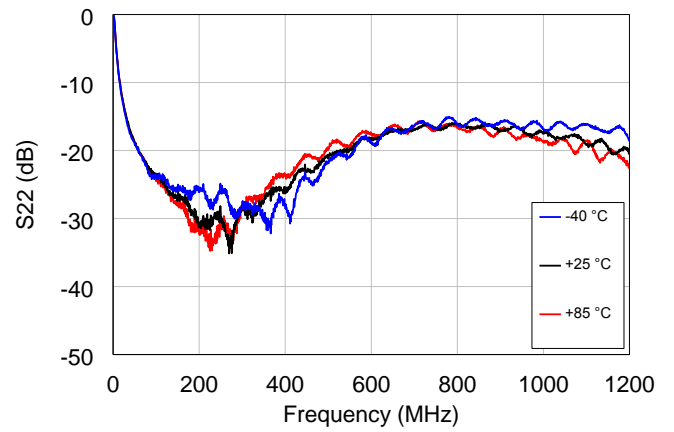
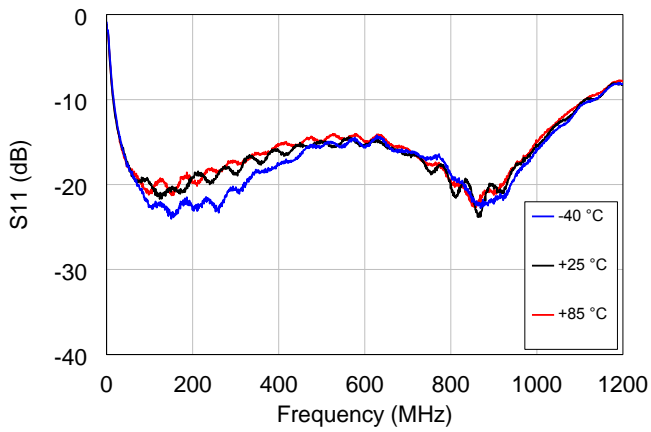
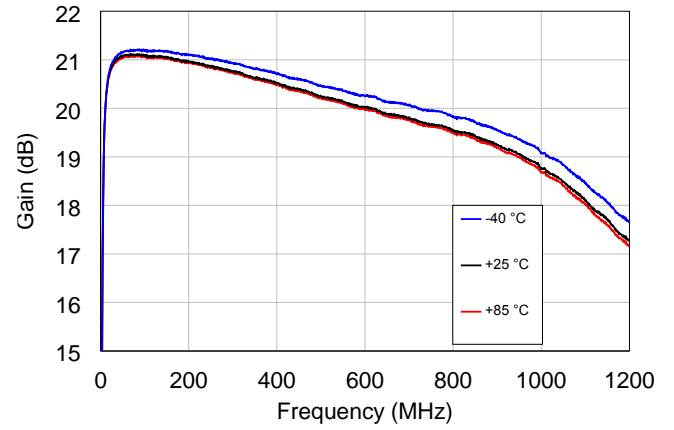
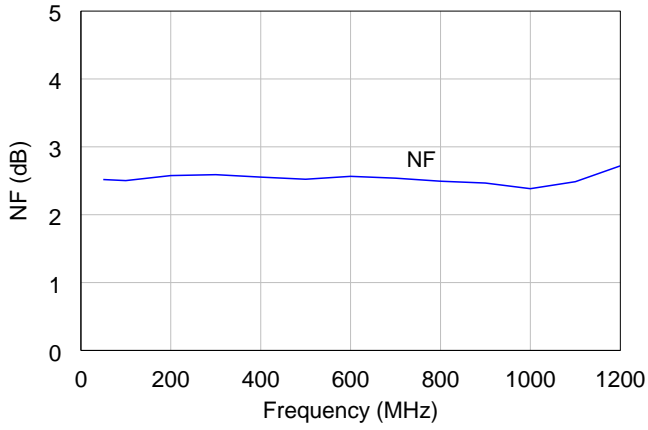

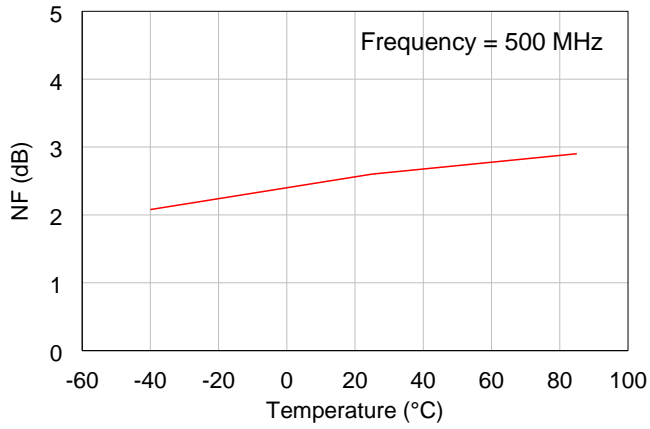

(Intentionally Blanked)

4. Application: 50 ~ 1200 MHz (CATV forward, $V_{supply} = +8 V$)

4.1 Application Circuit & Evaluation Board

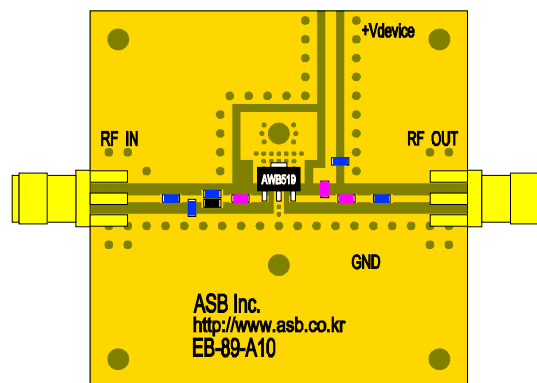
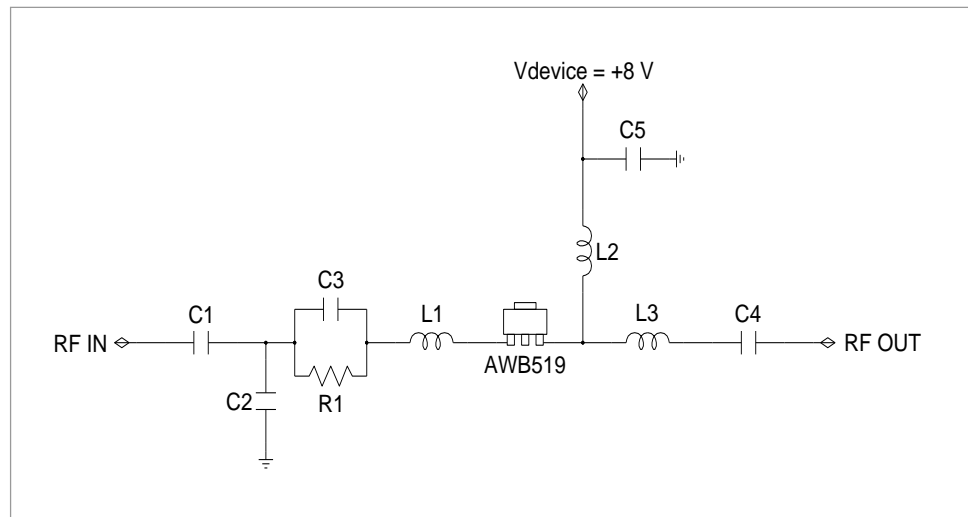

PCB Information	
Material	FR4
Thickness (mm)	0.8
Size (mm)	40x40
EB No.	EB-89-A10

Bill of Material

Symbol	Value	Size	Description	Manufacturer
AWB519	-	-	MMIC Amplifier	ASB
C1, C4	1 μ F	0603	DC blocking capacitor	Murata
C2	0.5 pF	0603	Matching capacitor	Murata
C3	33 pF	0603	Matching capacitor	Murata
C5	10 μ F	0805	Decoupling capacitor	Murata
L1	6.8 nH	0603	Matching inductor	Murata
L2	1 μ H	1206	RF choke inductor	Murata
L3	5.6 nH	0603	Matching inductor	Murata
R1	18 Ω	0603	Matching resistor	Samsung

4.2 Performance Table

Supply voltage = +8 V, $T_A = +25\text{ }^\circ\text{C}$, $Z_0 = 75\ \Omega$.

Parameter	Forward				Unit
Frequency	50	500	1002	1200	MHz
Noise Figure	3.4	2.4	2.1	2.7	dB
Gain	20.0	20.1	19.0	18.3	dB
S11	-17	-14	-19	-18	dB
S22	-14	-21	-16	-13	dB
Current	135				mA
Device Voltage	+8				V

4.3 Plot of S-parameter & Stability Factor

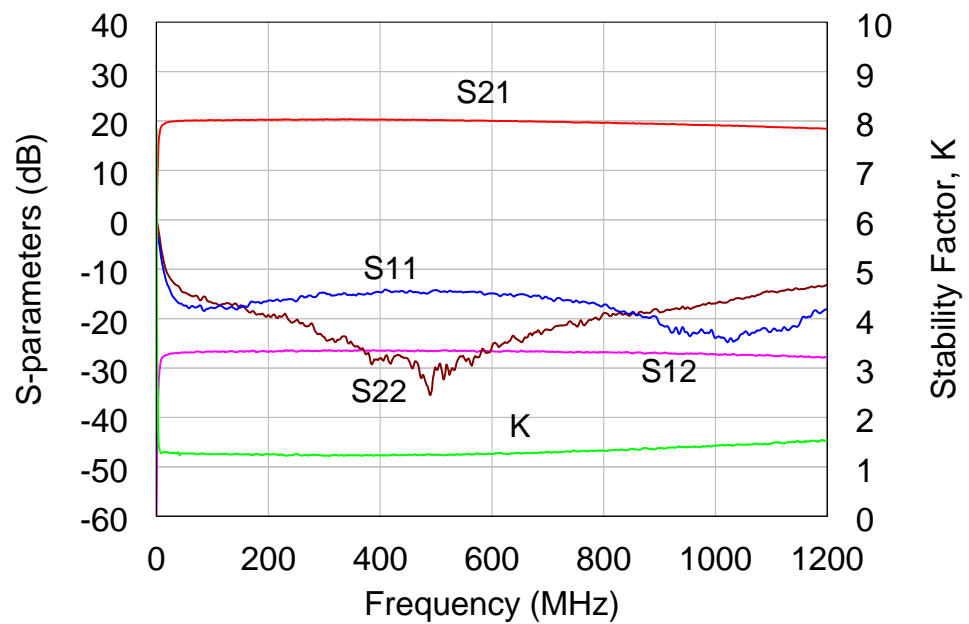

5. Application: 5 ~ 300 MHz (CATV reverse, $V_{supply} = +8 V$)

5.1 Application Circuit & Evaluation Board

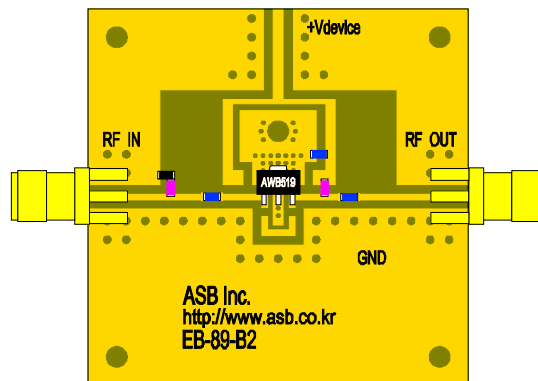
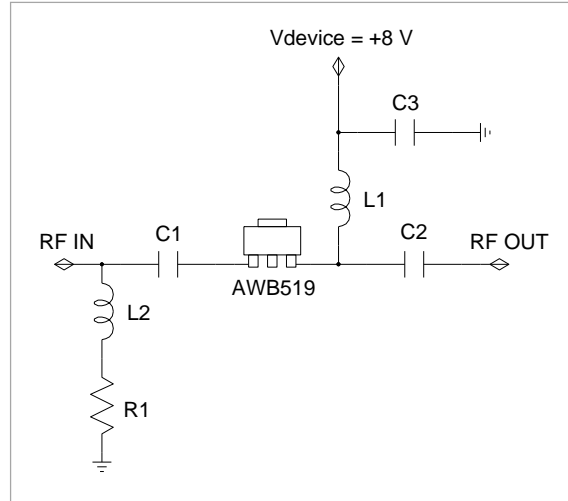

PCB Information	
Material	FR4
Thickness (mm)	0.8
Size (mm)	40x40
EB No.	EB-89-B2

Bill of Material

Symbol	Value	Size	Description	Manufacturer
AWB519	-	-	MMIC Amplifier	ASB
C1, C2	1 μ F	0603	DC blocking capacitor	Murata
C3	10 μ F	0805	Decoupling capacitor	Murata
L1	22 μ H	1206	RF choke inductor	Murata
L2	6.8 μ H	0603	Matching inductor	Samsung
R1	300 Ω	0603	Matching resistor	Samsung

5.2 Performance Table

Supply voltage = +8 V, T_A = +25 °C, Z₀ = 75 Ω.

Parameter	Reverse			Unit
Frequency	5	50	300	MHz
Noise Figure	-	2.5	2.7	dB
Gain	20.9	21.1	20.3	dB
S11	-20.5	-25.0	-16.0	dB
S22	-20.0	-27.0	-14.5	dB
Output P1dB	24.5	25.5	25.5	dBm
Output IP3 ¹⁾	36.0	40.5	42.0	dBm
Output IP2 ^{1), 2)}	55	53	57	dBm
Current	135			mA
Device Voltage	+8			V

1) OIP3 and OIP2 are measured with two tones at the output power of +10 dBm/tone separated by 6 MHz.
 2) OIP2 is measured at F1+F2 Frequency.

5.3 Plot of S-parameter & Stability Factor

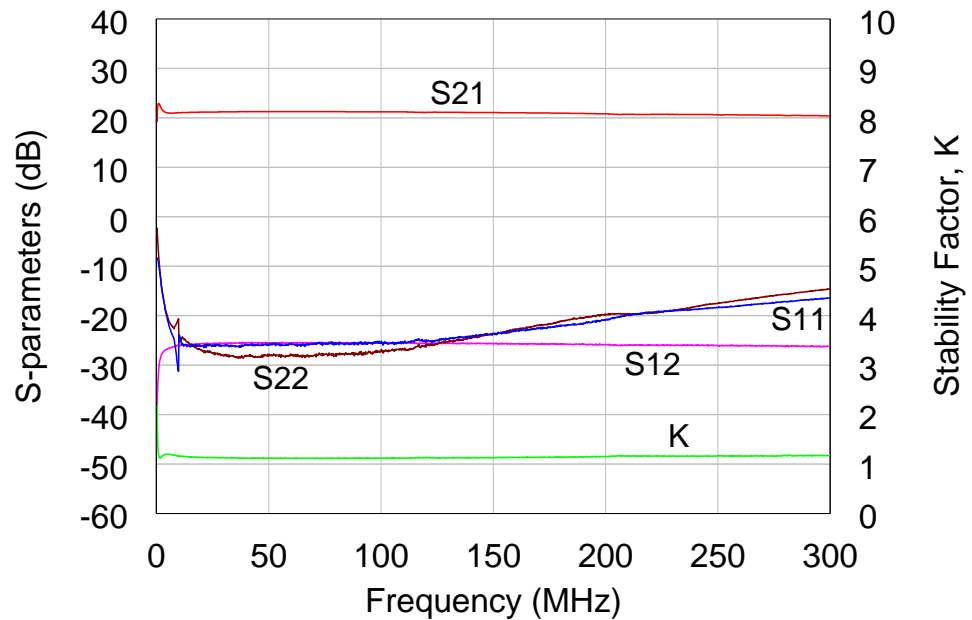

5.4 Plots of Noise Figure and Performances with Temperature

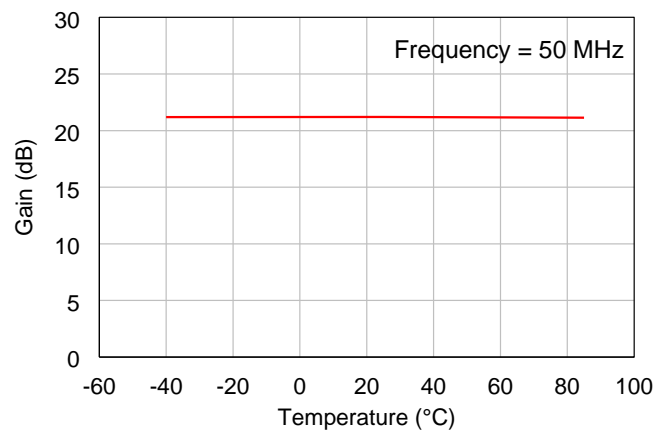
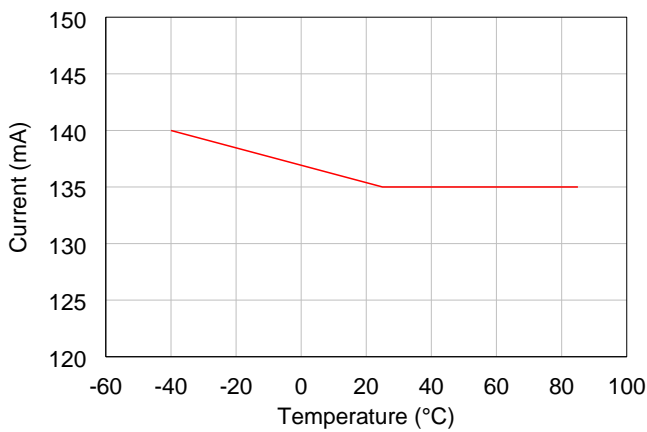
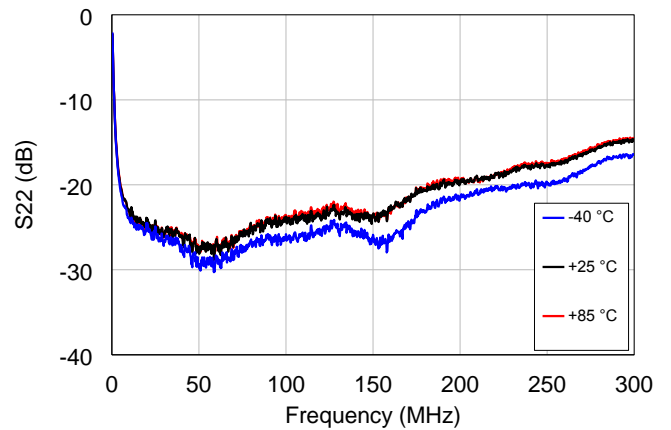
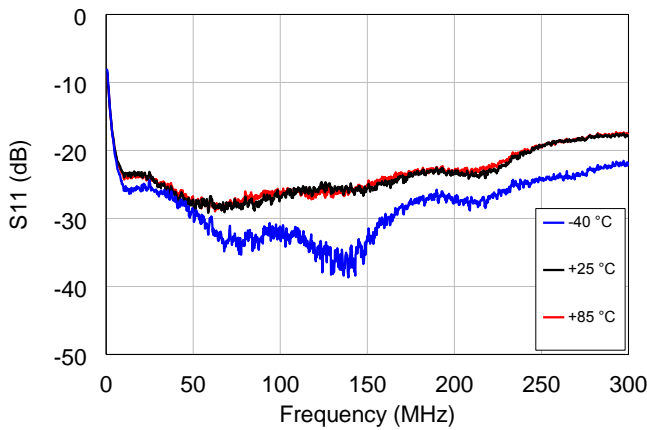
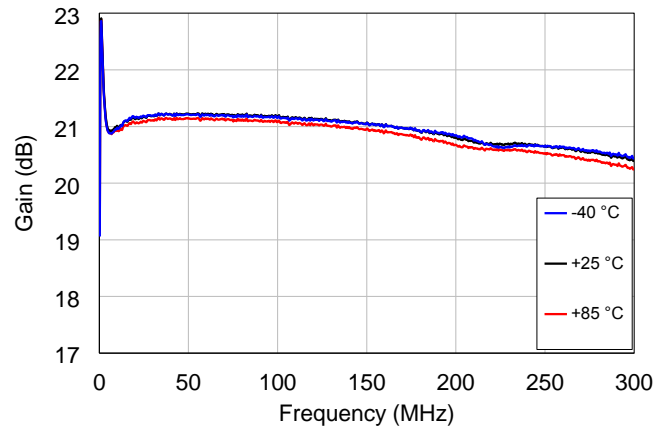
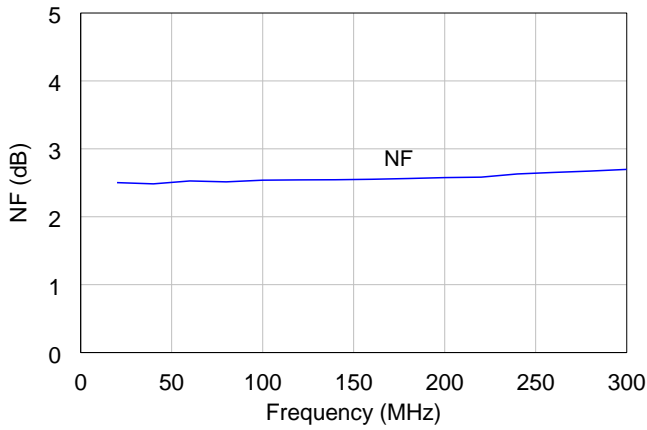

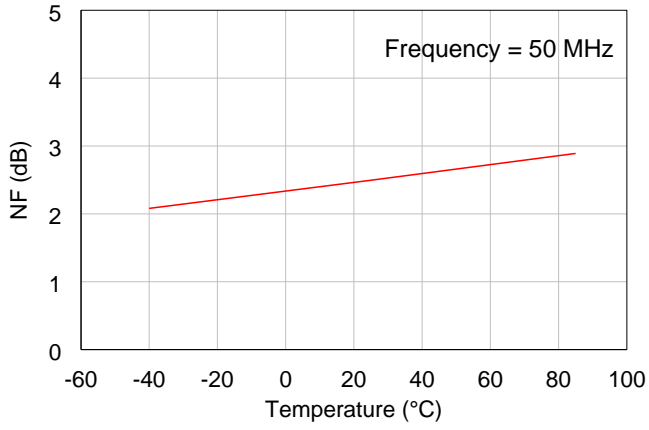

(Intentionally Blanked)

6. Application: 50 ~ 1000 MHz (CATV Min VSWR, $V_{supply} = +8 V$)

6.1 Application Circuit & Evaluation Board

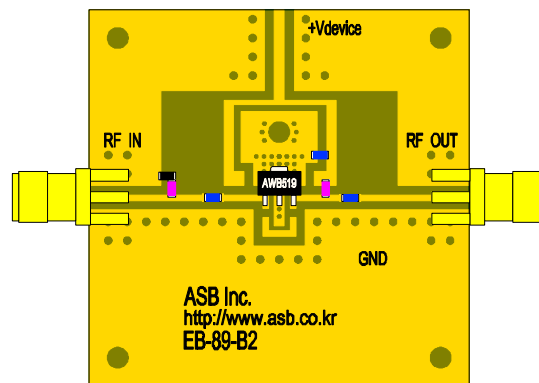
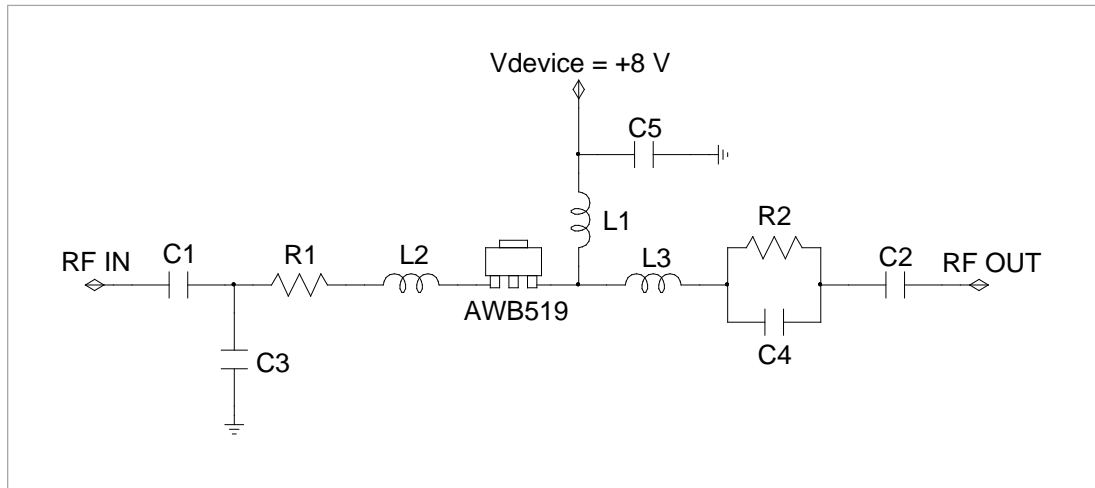

PCB Information	
Material	FR4
Thickness (mm)	0.8
Size (mm)	40x40
EB No.	EB-89-B2

Bill of Material

Symbol	Value	Size	Description	Manufacturer
AWB519	-	-	MMIC Amplifier	ASB
C1, C2	1 μ F	0603	DC blocking capacitor	Murata
C3	1 pF	0603	Matching capacitor	Murata
C4	33 pF	0603	Matching capacitor	Murata
C5	10 μ F	0805	Decoupling capacitor	Murata
L1	1 μ H	1206	RF choke inductor	Murata
L2	8.2 nH	0603	Matching inductor	Samsung
L3	6.8 nH	0603	Matching inductor	Samsung
R1	3.9 Ω	0603	Matching resistor	Samsung
R2	16 Ω	0603	Matching resistor	Samsung

6.2 Performance Table

Supply voltage = +8 V, T_A = +25 °C, Z_O = 75 Ω.

Parameter	Reverse			Unit
Frequency	50	500	1000	MHz
Noise Figure	2.6	2.5	2.5	dB
Gain	19.8	19.7	18.4	dB
S11	-18	-18	-19	dB
S22	-20	-19	-18	dB
Output P1dB	24.5	24.5	25.0	dBm
Output IP3 ¹⁾	41	41	41	dBm
Output IP2 ^{1), 2)}	55	61	51	dBm
Current	135			mA
Device Voltage	+8			V

1) OIP3 and OIP2 are measured with two tones at the output power of +10 dBm/tone separated by 6 MHz.
 2) OIP2 is measured at F1+F2 Frequency.

6.3 Plot of S-parameter & Stability Factor

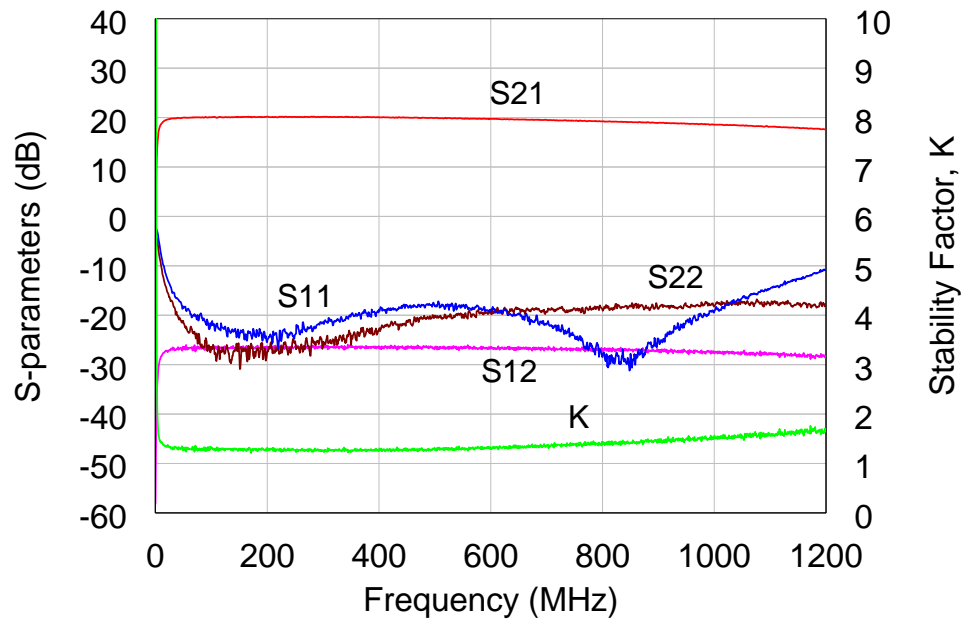

7. Package Outline (SOT89, 4.5x4.0x1.5 mm)

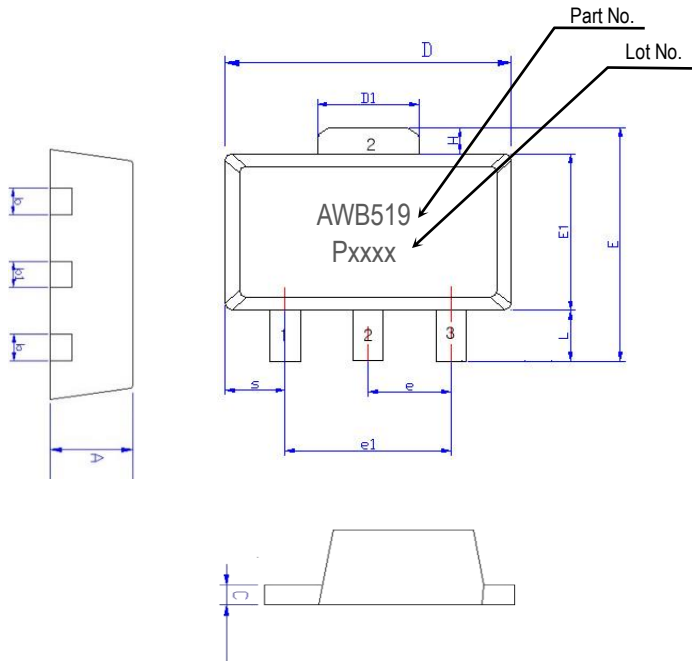

Symbols	Dimensions (In mm)		
	MIN	NOM	MAX
A	1.40	1.50	1.60
L	0.89	1.04	1.20
b	0.36	0.42	0.48
b1	0.41	0.47	0.53
C	0.38	0.40	0.43
D	4.40	4.50	4.60
D1	1.40	1.60	1.75
E	3.64	---	4.25
E1	2.40	2.50	2.60
e1	2.90	3.00	3.10
H	0.35	0.40	0.45
S	0.65	0.75	0.85
e	1.40	1.50	1.60

8. Surface Mount Recommendation (In mm)

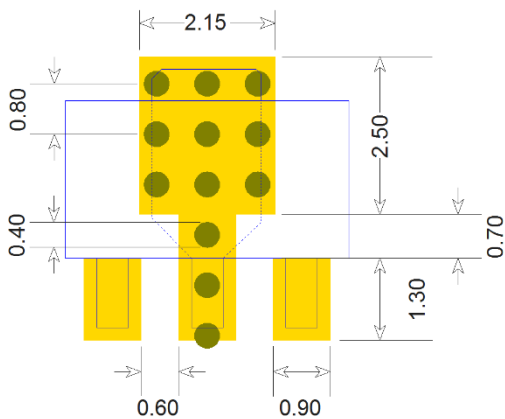

NOTE

1. The number and size of ground via holes in a circuit board are critical for thermal and RF grounding considerations.
2. Recommended is that the ground via holes be placed on the bottom of the lead pin 2 and exposed pad of the device for better RF and thermal performance, as shown in the drawing at the left side.

9. Recommended Soldering Reflow Profile

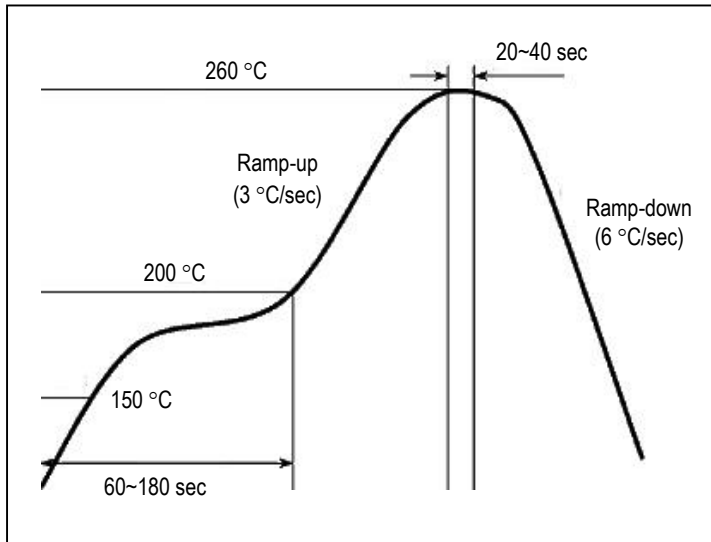

10. Family Products Information

ASB's AWB-series single-ended CATV amplifiers are available in different gain levels such as 12 dB, 17 dB, and 20 dB in which they are categorized by two groups according to the device voltage, 5 V and 8 V, so that a user can select the amplifier for different gain stages to design their system with ease. In addition, AWB3xx group for 5 V and AWB5xx group for 8 V are provided by almost the same external matching circuit and in a SOT89 package.

Part Number	Description	Package Type
AWB312	5 ~ 6 V, 12 dB gain CATV amplifier	SOT89
AWB317	5 V, 17 dB gain CATV amplifier	SOT89
AWB319	5 V, 20 dB gain CATV amplifier	SOT89
AWB512	8 V, 12 dB gain CATV amplifier	SOT89
AWB517	8 V, 17 dB gain CATV amplifier	SOT89
AWB519	8 V, 20 dB gain CATV amplifier	SOT89

(End of Datasheet)