

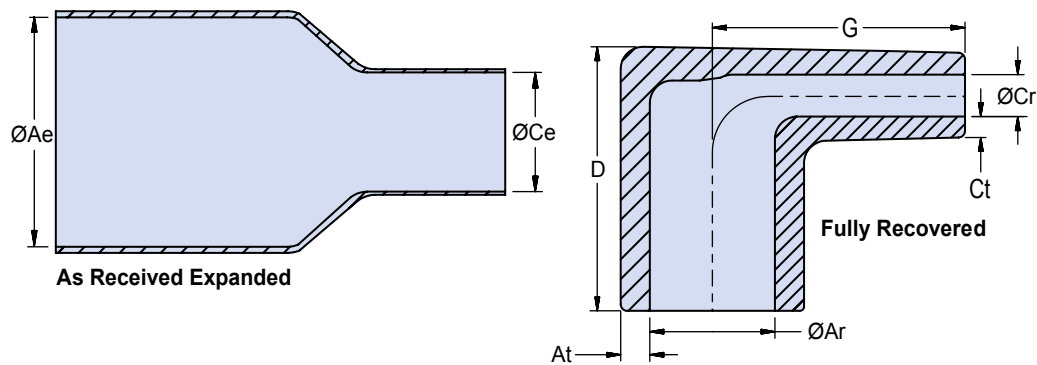

770-031 Right Angle Heat Shrink Boot

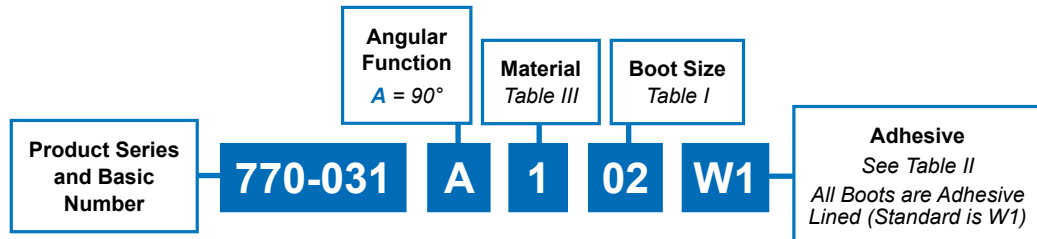

**TABLE I: Boot Size and Shrink Boot Dimensions**

Boot Size	Glenair US Part Marking (Engraved on Boot)	Ae Min Dia	Ar Max Dia	At ± 10%	Ce Min Dia	Cr Max Dia	Ct ± 10%	G ± 10%	D ± 10%
01	SF1A	.370 (9.40)	.160 (4.06)	.040 (1.02)	.180 (4.57)	.045 (1.14)	.030 (0.76)	.300 (7.62)	.380 (9.65)
02	SF2A	.370 (9.40)	.200 (5.08)	.045 (1.14)	.180 (4.57)	.065 (1.65)	.031 (0.79)	.375 (9.53)	.395 (10.0)
03	SF3A	.560 (14.2)	.260 (6.60)	.050 (1.27)	.370 (9.40)	.095 (2.41)	.035 (0.89)	.440 (11.20)	.469 (11.9)

**TABLE II: Glenair Series 77 Boots Adhesive Types**

Attribute	W1 Standard High Temperature Hot Melt Adhesive	W2 Hot Melt Adhesive	R High Performance Epoxy Adhesive
Boot Material Compatibility	Type 1, 2, 5, 6 and 7	Type 1, 2, 3 and 7	Type 1, 2, 5 and 6
Continuous Operating Temp.	-55° to +125°C	-40° to +80°C	-75° to +150°C
Resistance to Fuels, Oils & Fluids	Good	Good	Excellent
Low Toxicity, Zero Halogen	Yes	Yes	Yes

**TABLE III: Shrink Boot Materials**

No.	Compound	Material Description
1	2025	High Performance Elastomer*
2	2010	Zero Halogen Polyolefin*

\* Other Materials available

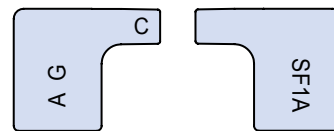

Boots are marked with manufacturer's identification and part number