

RQA0011DNS

R07DS0095EJ0600

Silicon N-Channel MOS FET

Rev.6.00

Mar 19, 2012

Features

- High output power, High gain, High efficiency
Pout = +40.2 dBm, Linear gain = 22.5 dB, PAE = 70% (f = 520 MHz)
- Small outline package (WSON0504-2: 5.0 × 4.0 × 0.8 mm)
- Electrostatic Discharge Immunity Test
(IEC Standard, 61000-4-2, Level4)

Outline

RENESAS Package code: PWSN0002ZA-B
(Package name: HWSN-2 <WSON0504-2>)

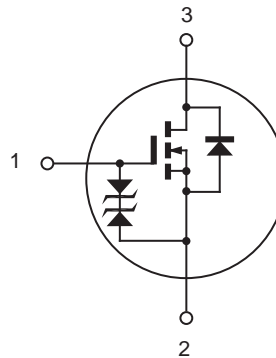
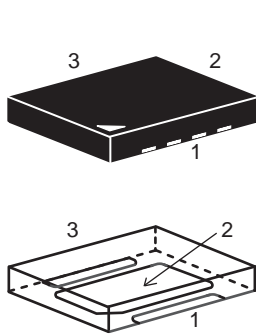

- 1. Gate
- 2. Source
- 3. Drain

Note: Marking is "RQA0011".

Absolute Maximum Ratings

(Ta = 25°C)

Item	Symbol	Ratings	Unit
Drain to source voltage	V _{DSS}	16	V
Gate to source voltage	V _{GSS}	±5	V
Drain current	I _D	3.8	A
Channel dissipation	P _{ch} ^{note}	15	W
Channel temperature	T _{ch}	150	°C
Storage temperature	T _{stg}	-55 to +150	°C

Note: Value at Tc = 25°C

This device is sensitive to electro static discharge. An adequate careful handling procedure is requested.

Electrical Characteristics

(Ta = 25°C)

Item	Symbol	Min.	Typ	Max.	Unit	Test Conditions
Zero gate voltage drain current	I_{DSS}	—	—	20	μA	$V_{DS} = 16 V, V_{GS} = 0$
Gate to source leak current	I_{GSS}	—	—	± 3	μA	$V_{GS} = \pm 5 V, V_{DS} = 0$
Gate to source cutoff voltage	$V_{GS(off)}$	0.25	0.4	0.75	V	$V_{DS} = 7.5 V, I_D = 1 mA$
Forward transfer admittance	$ y_{fs} $	3.8	4.8	5.8	S	$V_{DS} = 7.5 V, I_D = 2 A$
Input capacitance	C_{iss}	—	102	—	pF	$V_{GS} = 5 V, V_{DS} = 0, f = 1 MHz$
Output capacitance	C_{oss}	—	50	—	pF	$V_{DS} = 7.5 V, V_{GS} = 0, f = 1 MHz$
Reverse transfer capacitance	C_{rss}	—	4.5	—	pF	$V_{DG} = 7.5 V, V_{GS} = 0, f = 1 MHz$
Output power	P_{out}	—	33.9	—	dBm	$V_{DS} = 3.6 V, I_{DQ} = 200 mA,$ $f = 155 MHz,$ $P_{in} = +25 dBm (316 mW)$
		—	2.4	—	W	
Power added efficiency	PAE	—	62	—	%	
Output power	P_{out}	—	39.4	—	dBm	$V_{DS} = 7.5 V, I_{DQ} = 200 mA,$ $f = 155 MHz,$ $P_{in} = +25 dBm (316 mW)$
		—	8.8	—	W	
Power added efficiency	PAE	—	66	—	%	
Output power	P_{out}	—	33.8	—	dBm	$V_{DS} = 3.6 V, I_{DQ} = 200 mA,$ $f = 360 MHz,$ $P_{in} = +25 dBm (316 mW)$
		—	2.4	—	W	
Power added efficiency	PAE	—	60	—	%	
Output power	P_{out}	—	40.1	—	dBm	$V_{DS} = 7.5 V, I_{DQ} = 200 mA,$ $f = 360 MHz,$ $P_{in} = +25 dBm (316 mW)$
		—	10.2	—	W	
Power added efficiency	PAE	—	70	—	%	
Output power	P_{out}	—	35.8	—	dBm	$V_{DS} = 3.6 V, I_{DQ} = 200 mA,$ $f = 520 MHz,$ $P_{in} = +25 dBm (316 mW)$
		—	3.8	—	W	
Power added efficiency	PAE	—	60	—	%	
Output power	P_{out}	38.7	40.2	—	dBm	$V_{DS} = 7.5 V, I_{DQ} = 200 mA,$ $f = 520 MHz,$ $P_{in} = +25 dBm (316 mW)$
		7.4	10.4	—	W	
Power added efficiency	PAE	60	71	—	%	

Main Characteristics

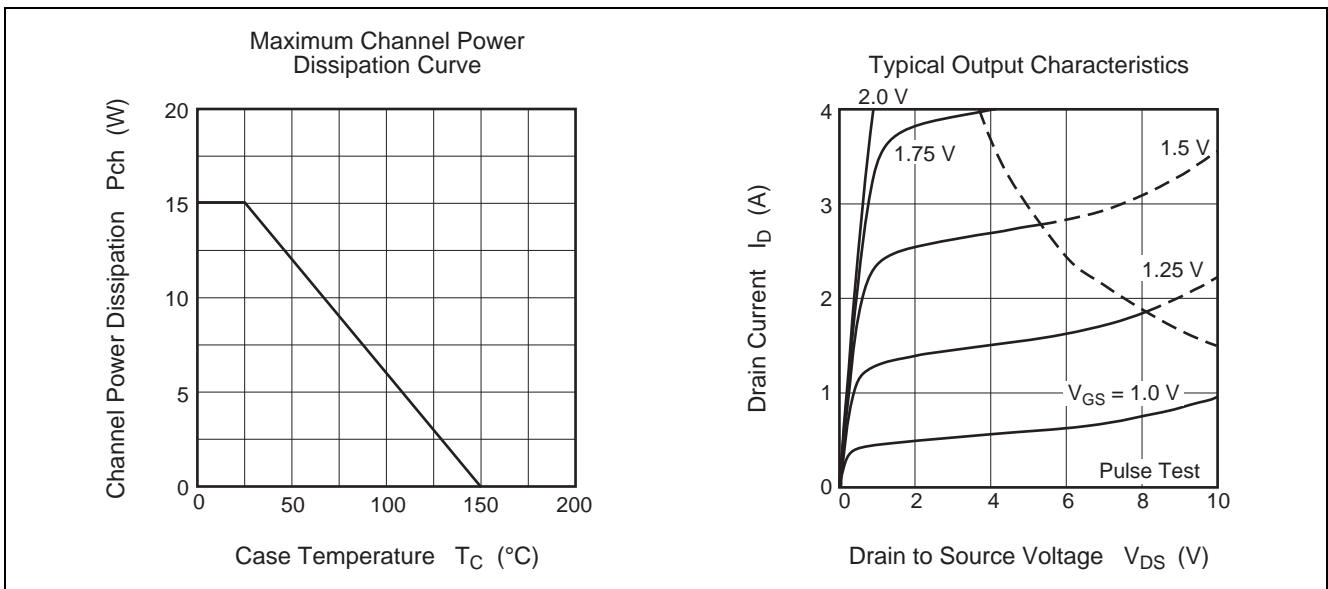

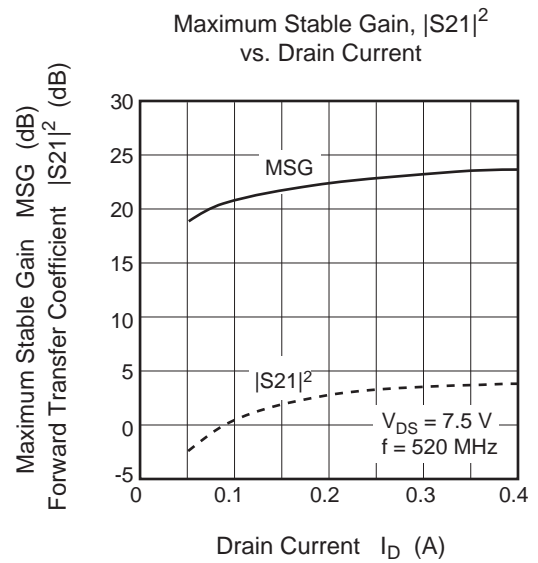
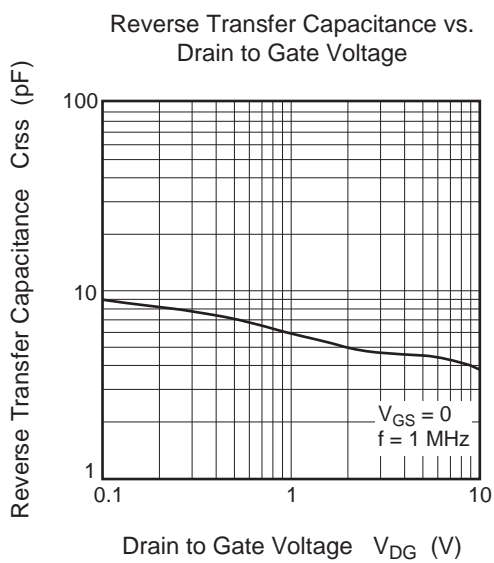
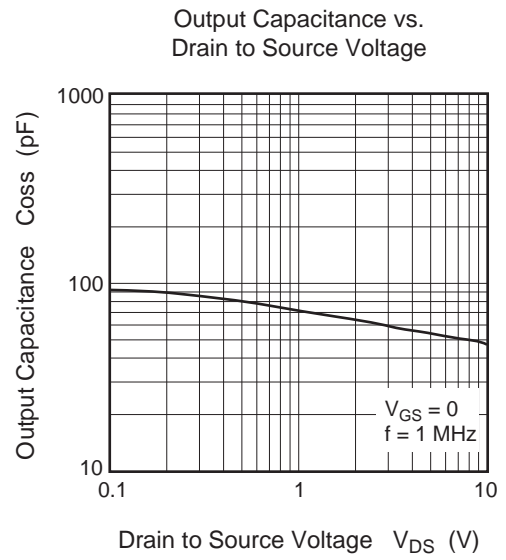
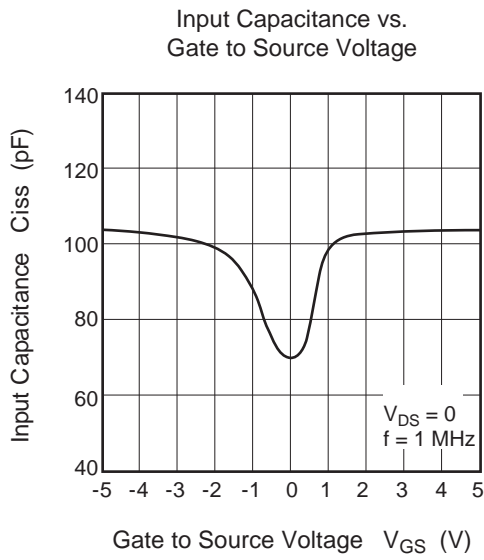
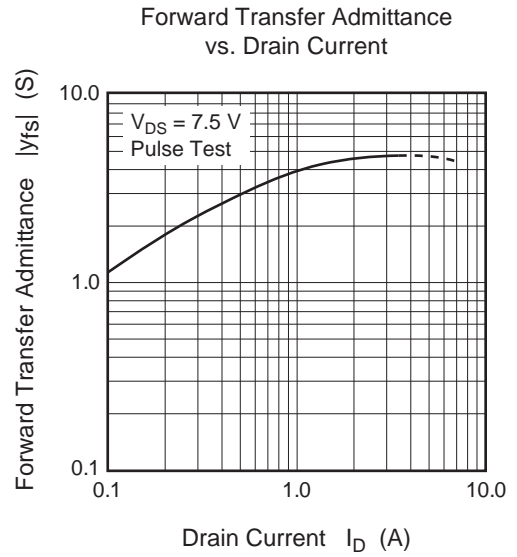
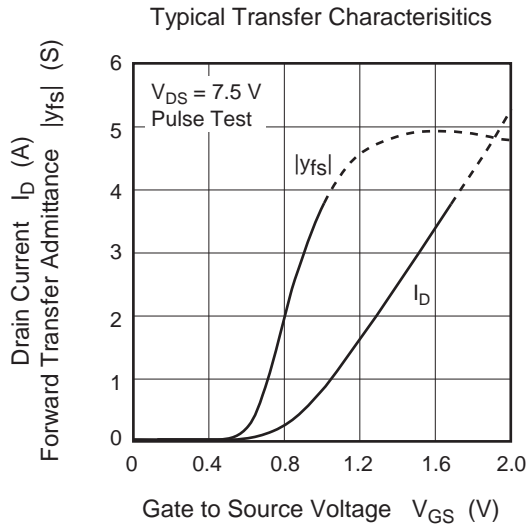

Evaluation Circuit 1 (@V_{DD} = 3.6 & 7.5V Tuning, f = 155 MHz)

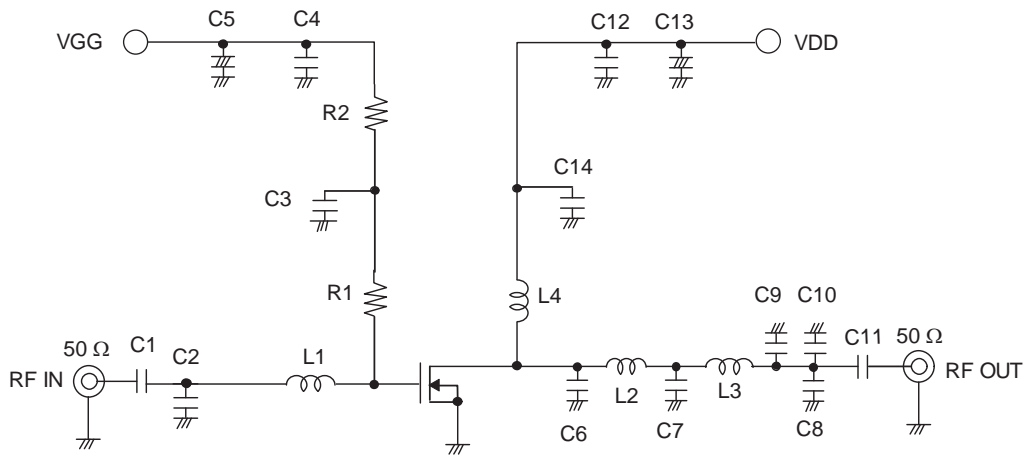

- C1, C3, C11, C14: 100 pF Chip Capacitor
- C2: 27 pF Chip Capacitor
- C4, C12: 1000 pF Chip Capacitor
- C5, C13: 1 μF /+16V Chip Tantalum Capacitor
- C6: 13 pF Chip Capacitor
- C7: 22 pF Chip Capacitor
- C8: 56 pF Chip Capacitor
- C9: 0.5 pF Chip Capacitor
- C10: 2 pF Chip Capacitor
- L1: 33 nH Chip Inductor
- L2: 3.6 nH Chip Inductor
- L3: 7.5 nH Chip Inductor
- L4: 8 Turns D : 0.5 mm, φ2.4 mm Enamel Wire
- R1: 33 Ω Chip Resistor
- R2: 6.8 kΩ Chip Resistor

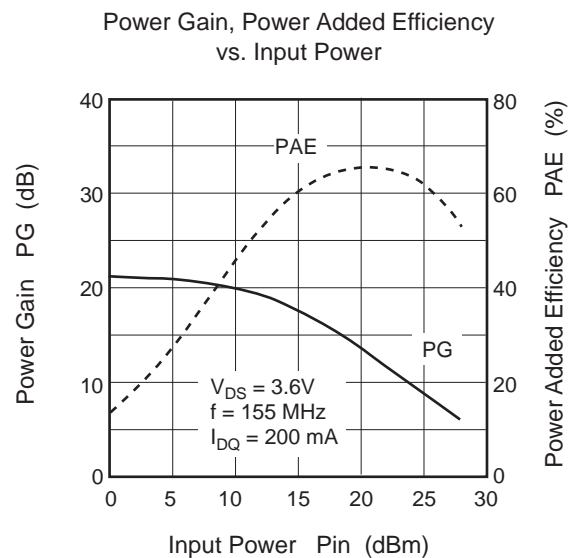
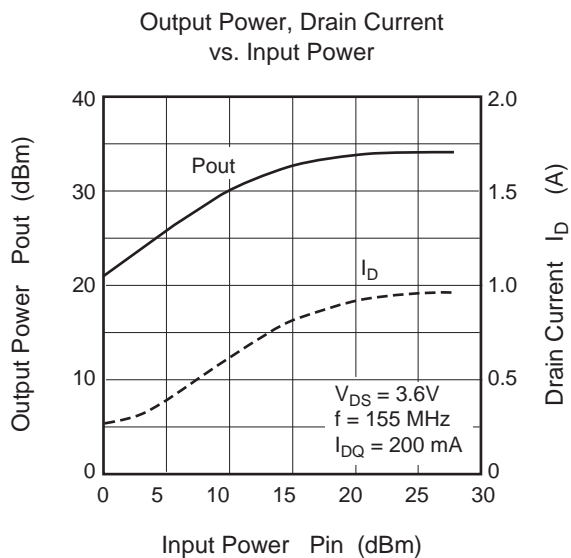

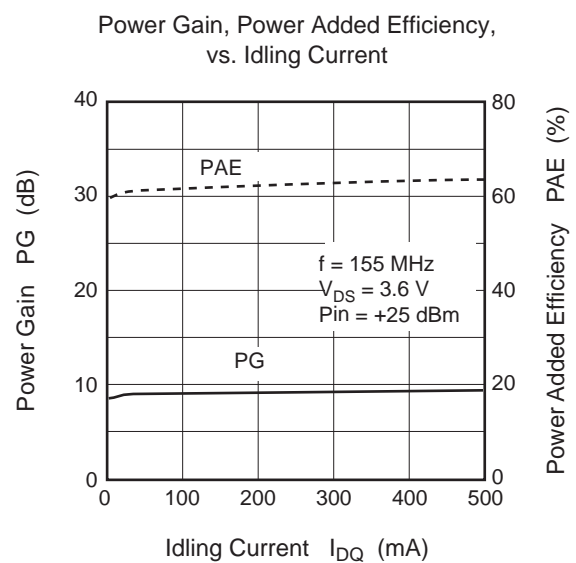
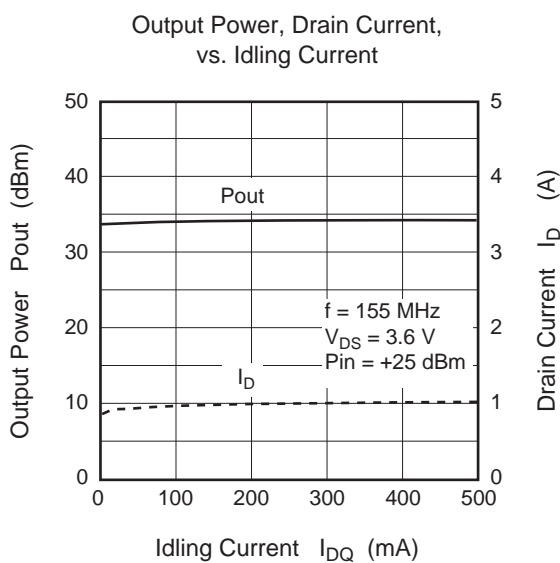
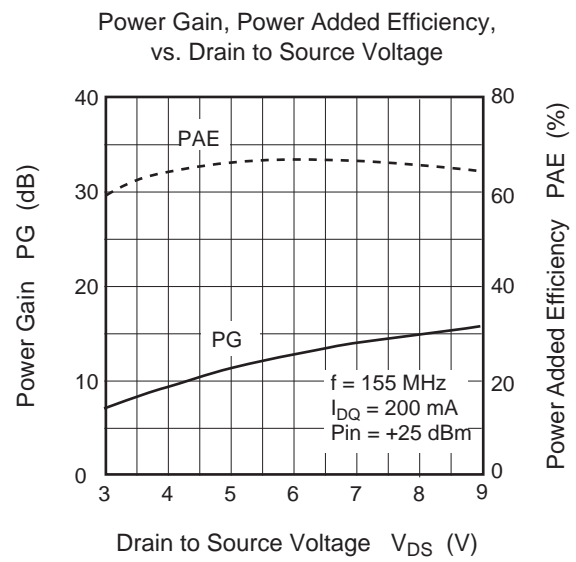
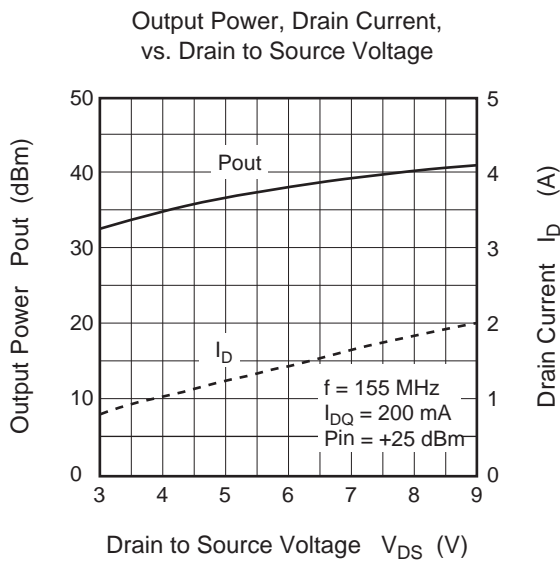
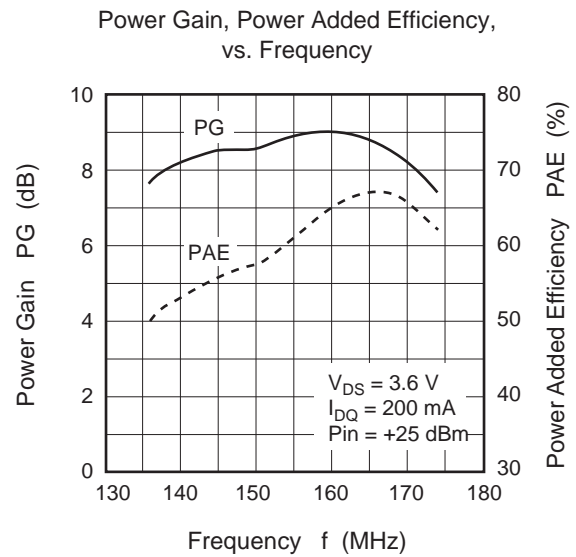
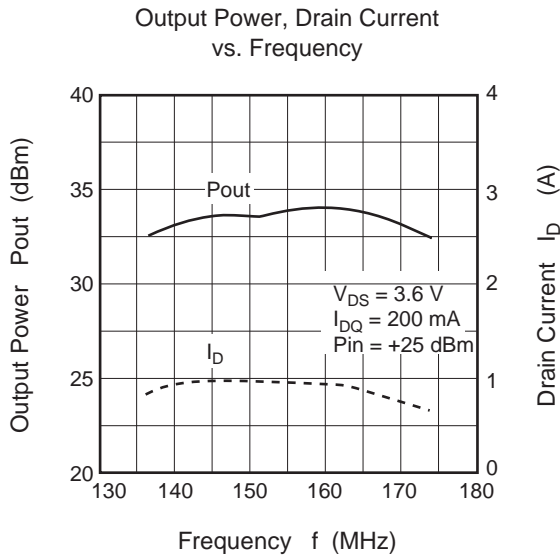

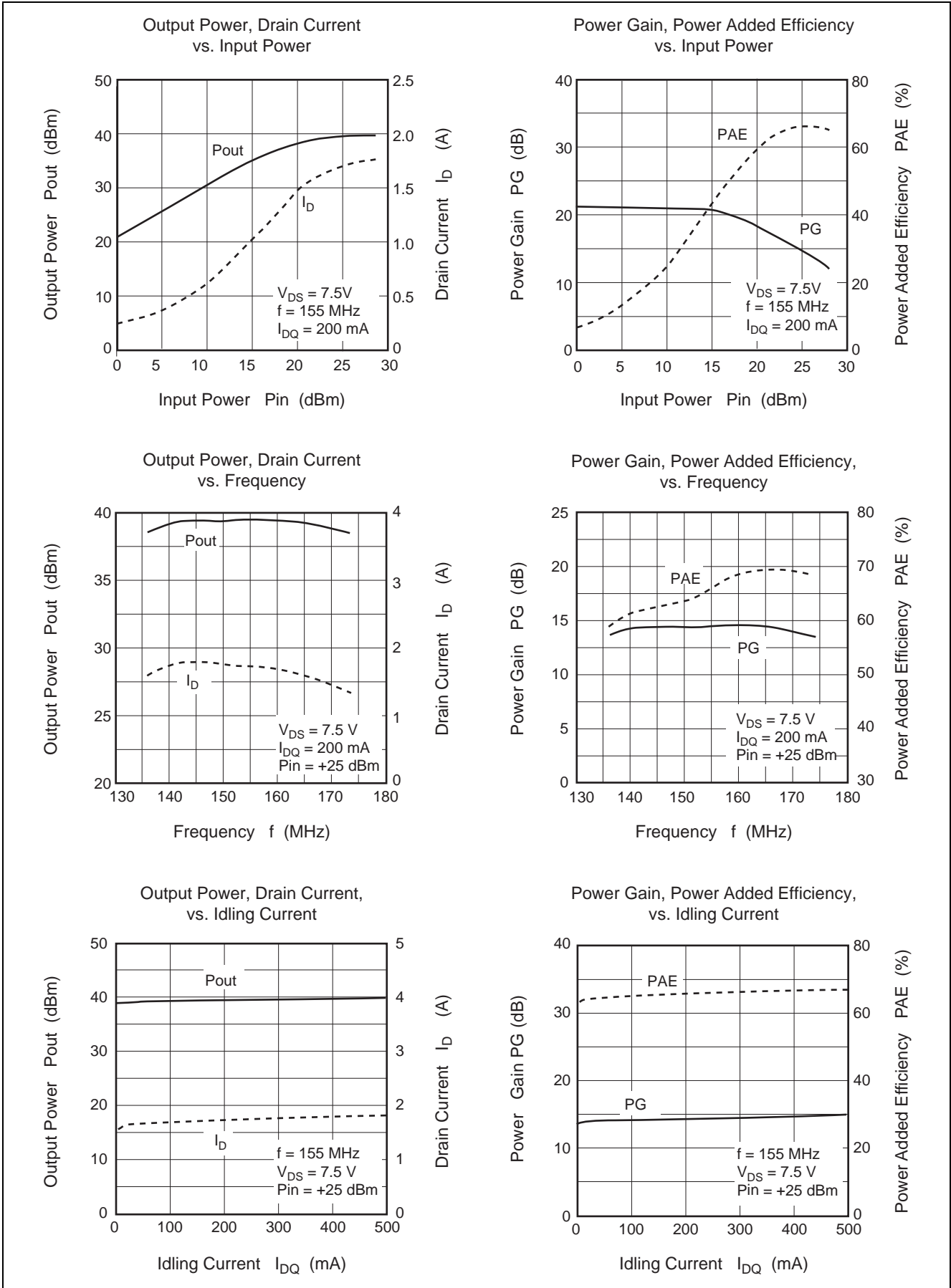

Evaluation Circuit 2 (@V_{DD} = 3.6 V Tuning, f = 360 MHz)

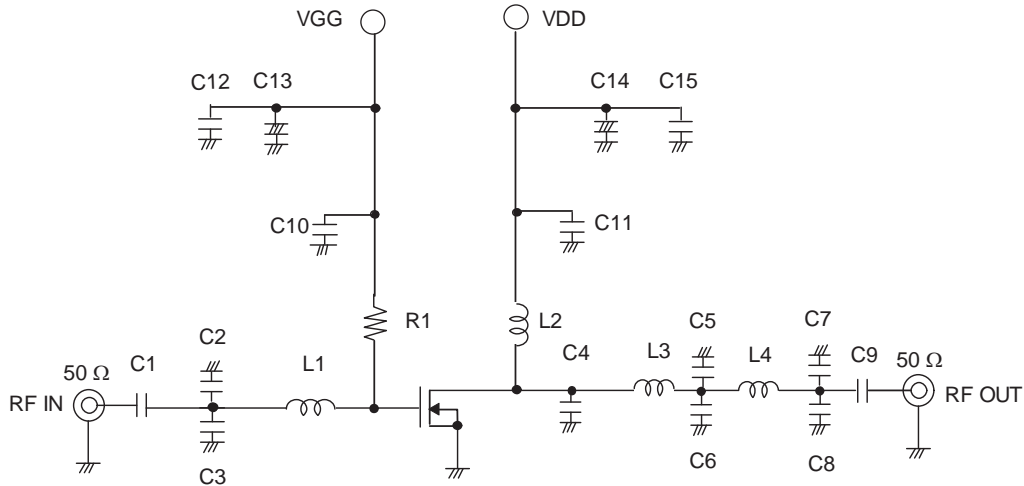

- C1 : 22pF Chip Capacitor
- C2, C3, C6, C7, C8 : 10 pF Chip Capacitor
- C4 : 5 pF Chip Capacitor
- C5 : 12 pF Chip Capacitor
- C9, C12, C15 : 1000 pF Chip Capacitor
- C10, C11 : 100 pF Chip Capacitor
- C13, C14 : 1 μF /+16V Chip Tantalum Capacitor
- L1: 6.8 nH Chip Inductor
- L2: 8 Turns D : 0.5 mm, φ2.4 mm Enamel Wire
- L3: 1 nH Chip Inductor
- L4: 2.7 nH Chip Inductor
- R1: 6.8 kΩ Chip Resistor

Output Power, Drain Current vs. Input Power

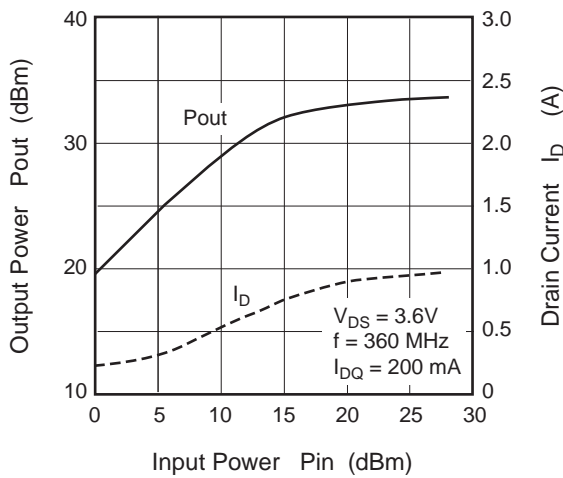

Power Gain, Power Added Efficiency vs. Input Power

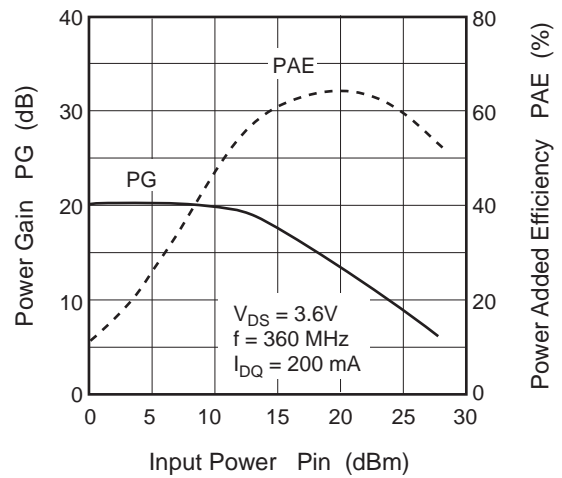

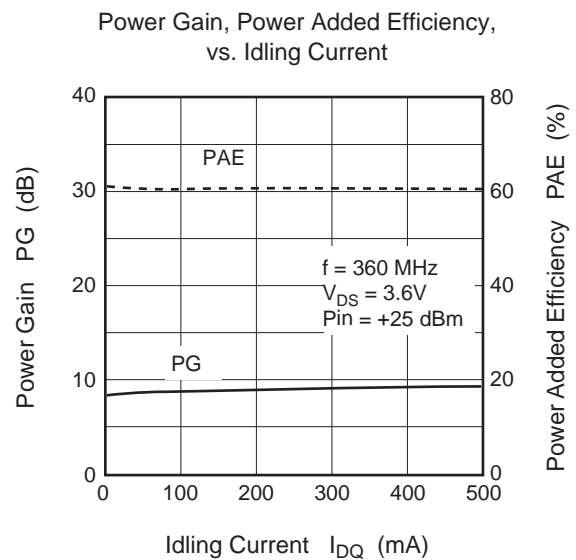
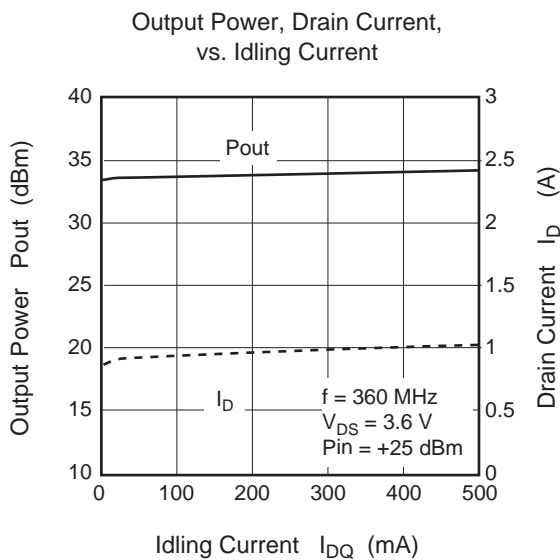
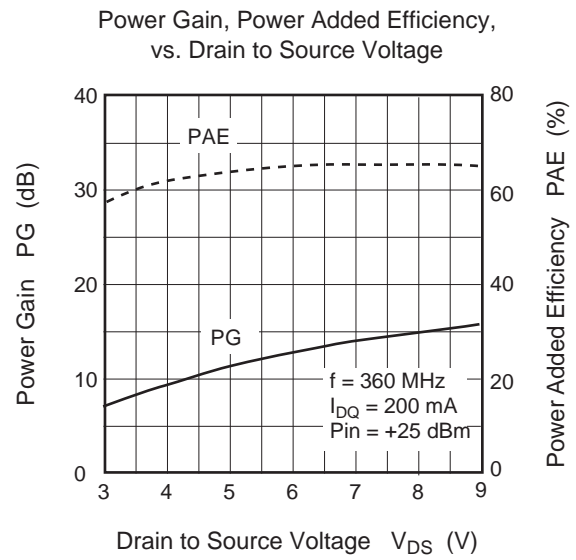
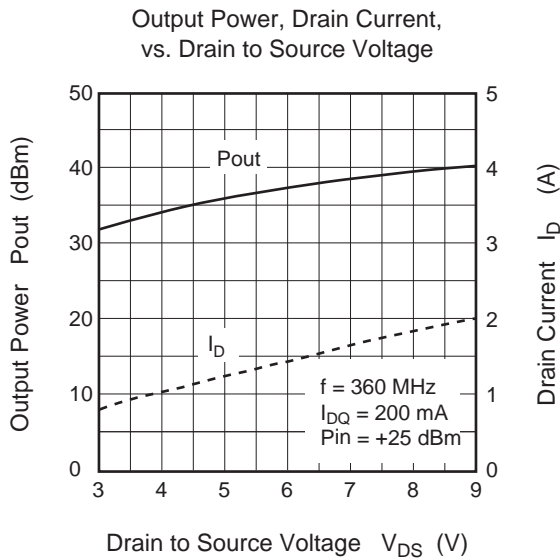
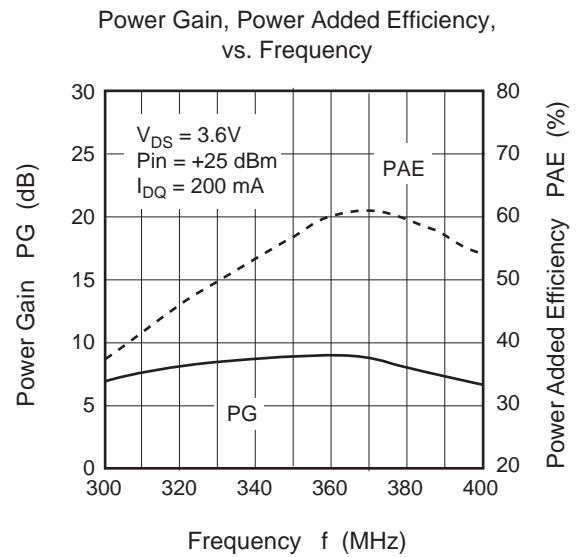
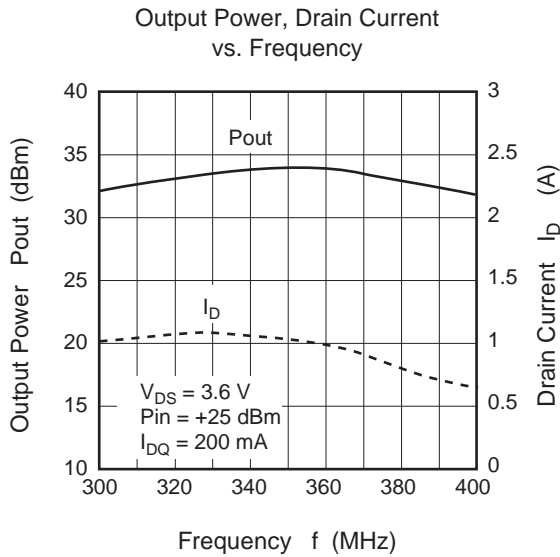

Evaluation Circuit 3 (@ $V_{DD} = 7.5\text{ V}$ Tuning, $f = 360\text{ MHz}$)

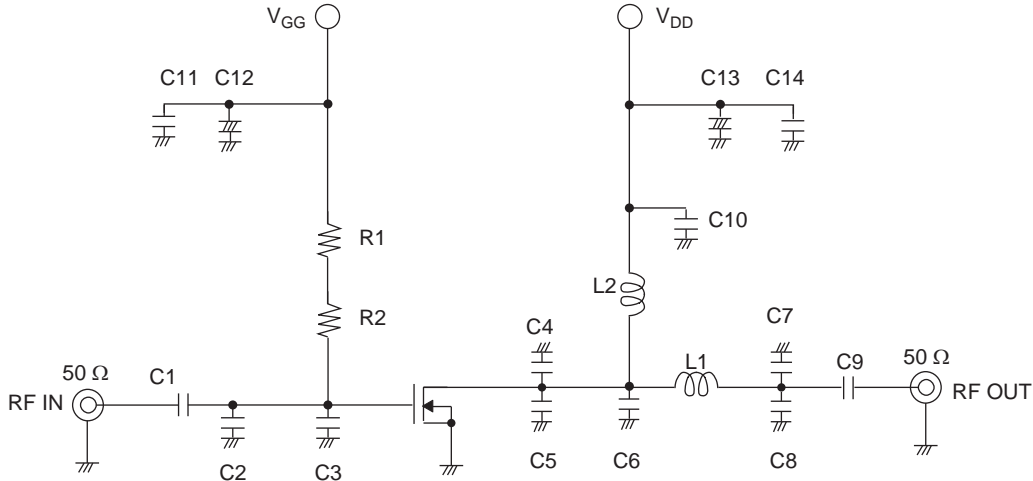

- C1,C9,C10 : 1000pF Chip Capacitor
- C2,C3 : 27pF Chip Capacitor
- C4: 12 pF Chip Capacitor
- C5 : 68 pF Chip Capacitor
- C6 : 33 pF Chip Capacitor
- C7 : 13 pF Chip Capacitor
- C8 : 8pF Chip Capacitor
- C11, C14 : 1000 pF Chip Capacitor
- C12, C13: 1 μF /+16V Chip Tantalum Capacitor
- L1: 3.6nH Inductor
- L2: 8 Turns D : 0.5 mm, ϕ 2.4 mm Enamel Wire
- R1: 6.8 k Ω Chip Resistor
- R2: 200 Ω Chip Resistor

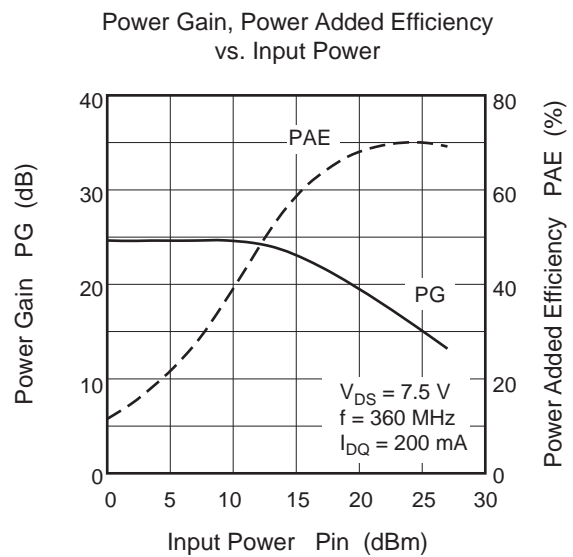
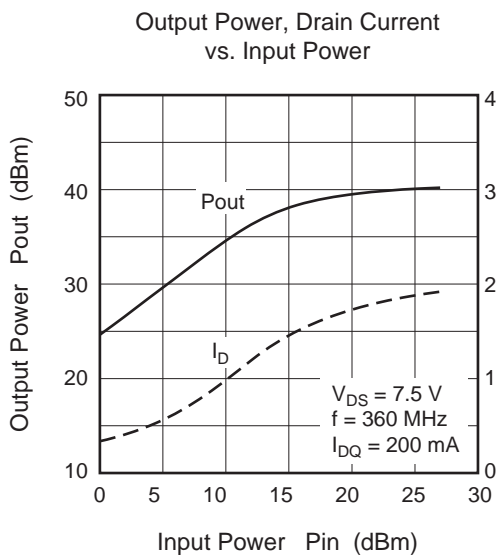

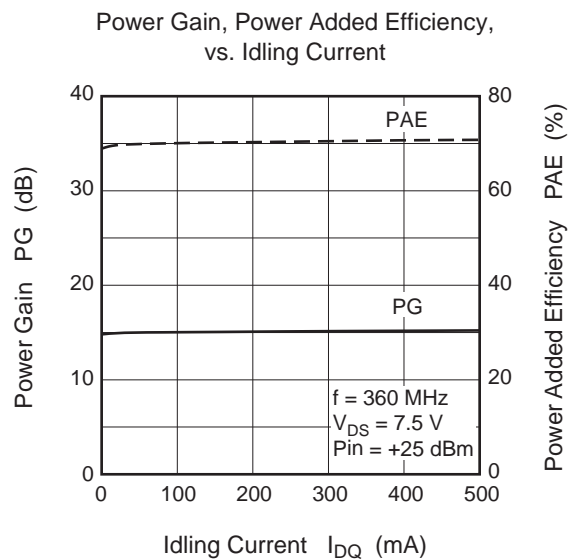
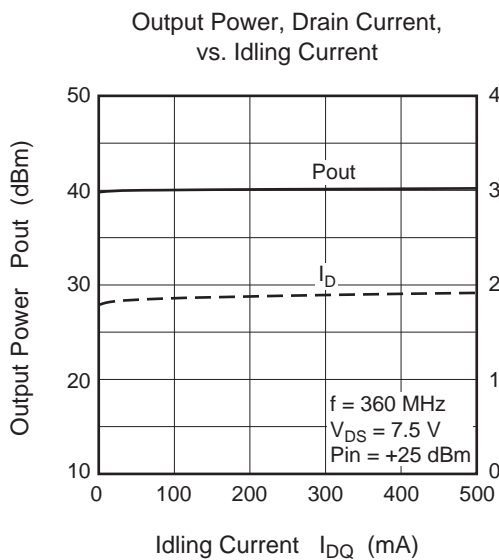
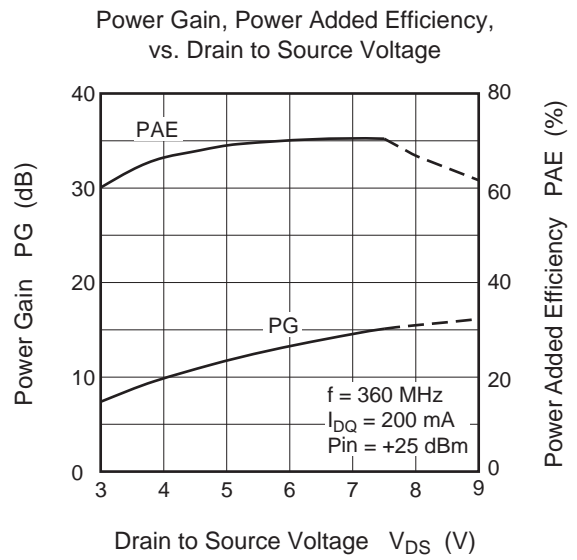
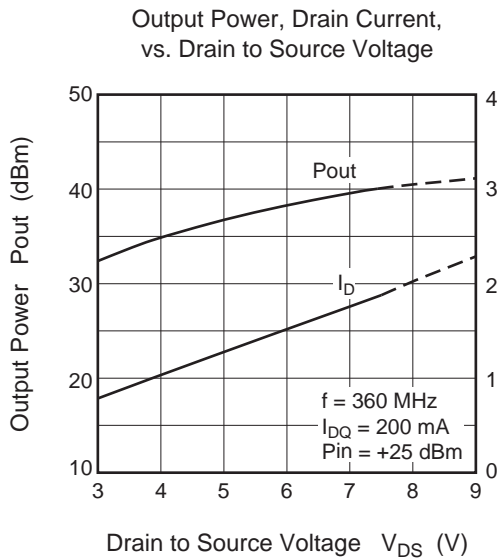
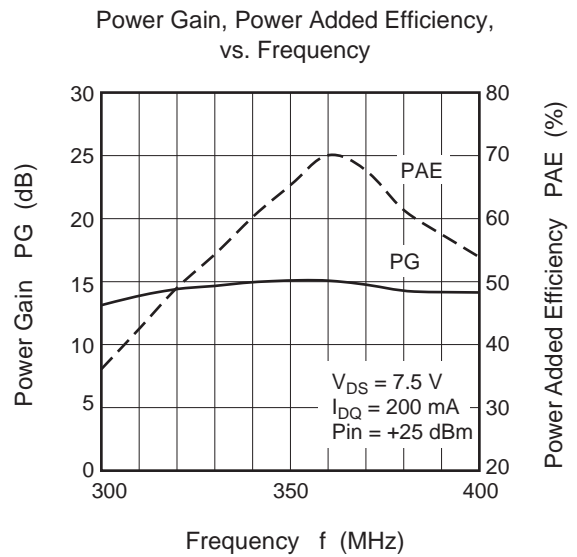
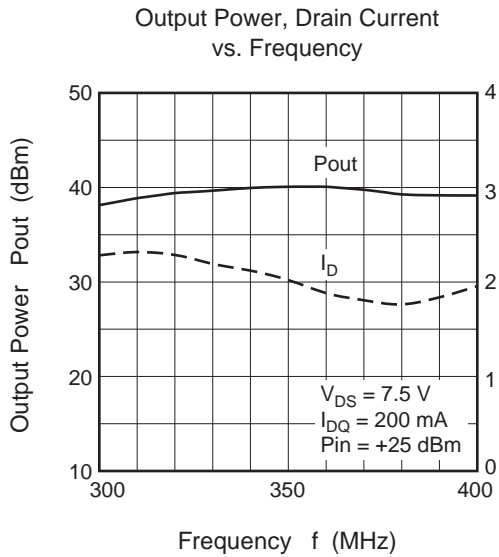

Evaluation Circuit 4 (@V_{DD} = 3.6 V Tuning, f = 520 MHz)

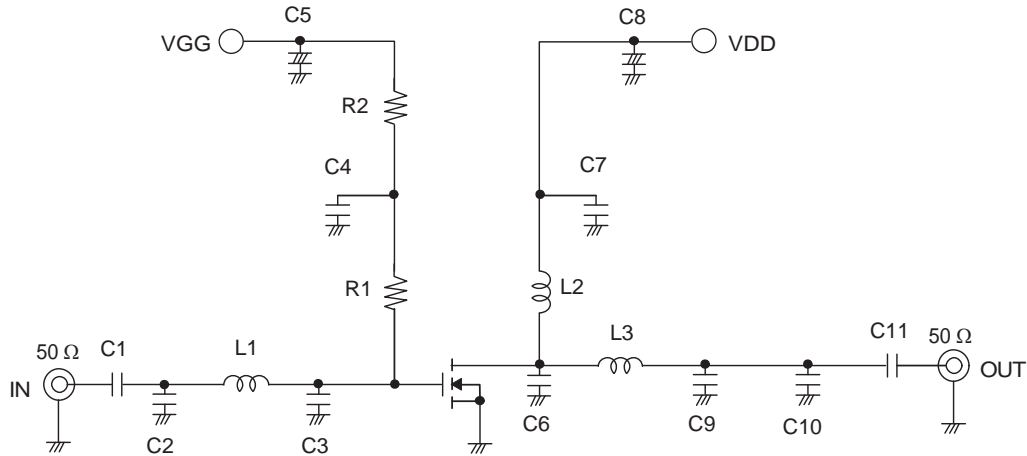

- C1, C11: 1000 pF Chip Capacitor
- C2: 20 pF Chip Capacitor
- C3, C10: 10 pF Chip Capacitor
- C4, C7: 100 pF Chip Capacitor
- C5, C8: 1 μ F /+16V Chip Tantalum Capacitor
- C6: 5 pF Chip Capacitor
- C9: 27 pF Chip Capacitor
- L1: 1.5 nH Chip Inductor
- L2: 8 Turns D : 0.5mm , ϕ 2.4 mm Enamel Wire
- L3: 1.2 nH Chip Inductor
- R1: 200 Ω Chip Resistor
- R2: 3 k Ω Chip Resistor

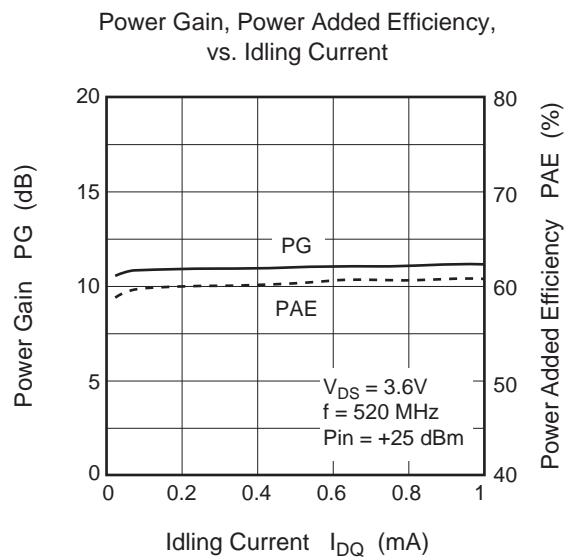
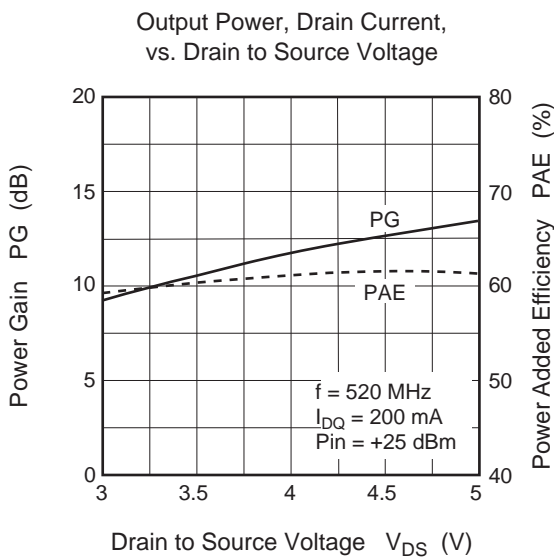
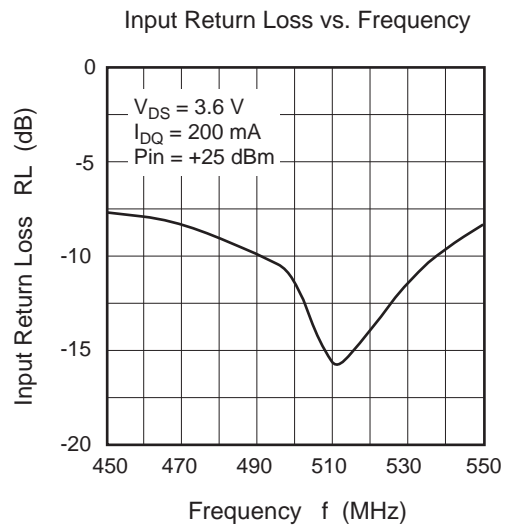
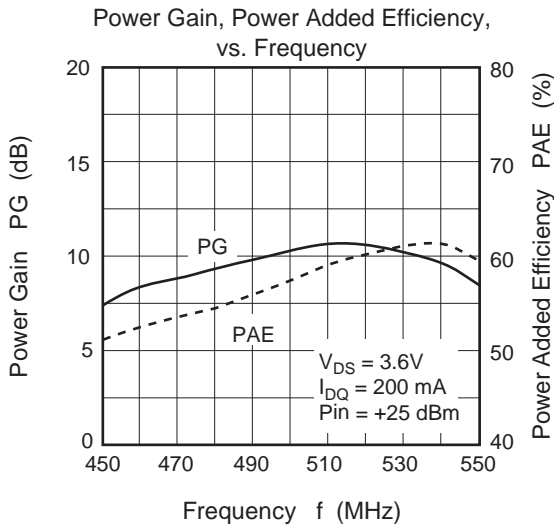
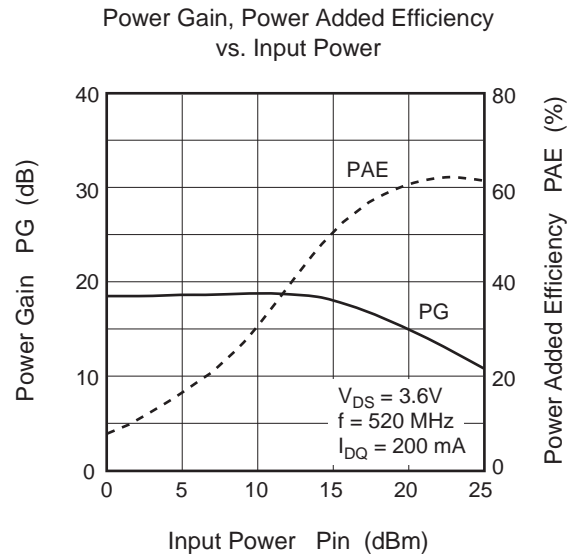
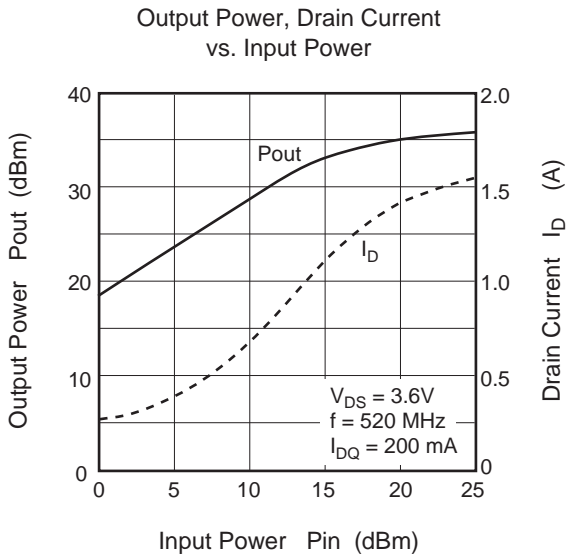

Evaluation Circuit 5 (@V_{DD} = 7.5 V Tuning, f = 520 MHz)

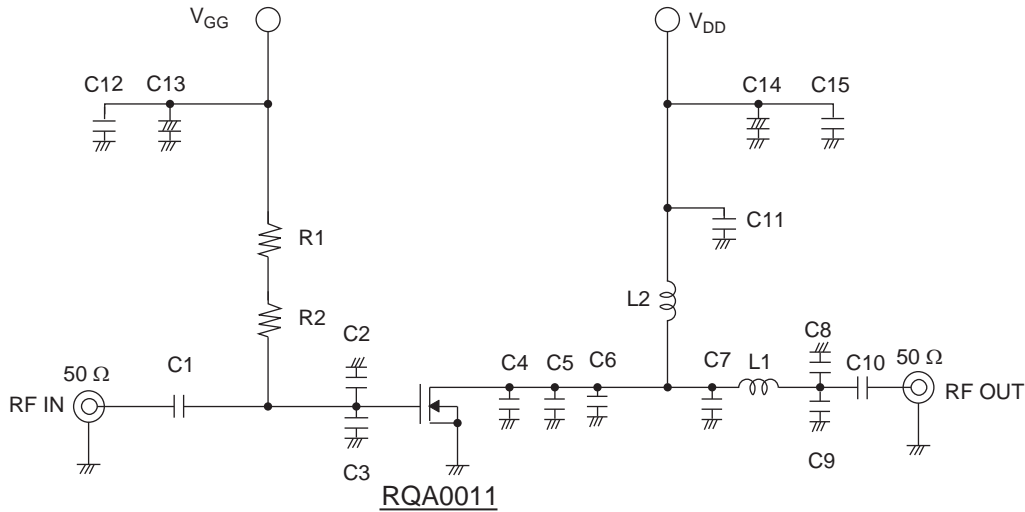

- C1,C10,C11 : 1000pF Chip Capacitor
- C2 : 27pF Chip Capacitor
- C3,C4,C5: 24 pF Chip Capacitor
- C6 : 15 pF Chip Capacitor
- C7 : 13 pF Chip Capacitor
- C8 : 1 pF Chip Capacitor
- C9 : 8pF Chip Capacitor
- C12, C15 : 1000 pF Chip Capacitor
- C13, C14 : 1 μF /+16V Chip Tantalum Capacitor
- L1: 3.6nH Inductor
- L2: 8 Turns D : 0.5 mm, φ2.4 mm Enamel Wire
- R1: 6.8 kΩ Chip Resistor
- R2: 200 Ω Chip Resistor

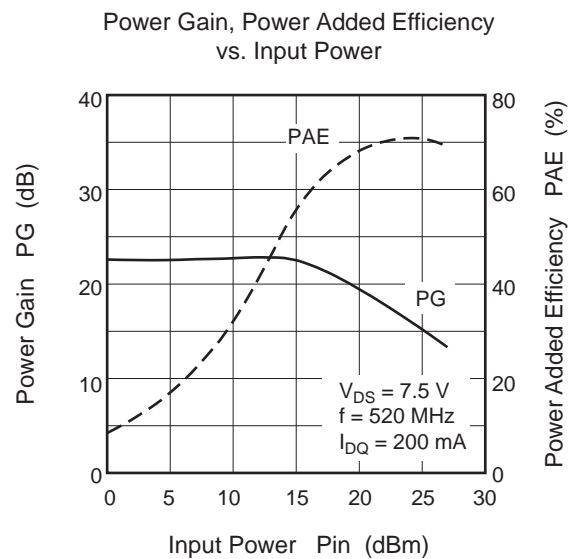
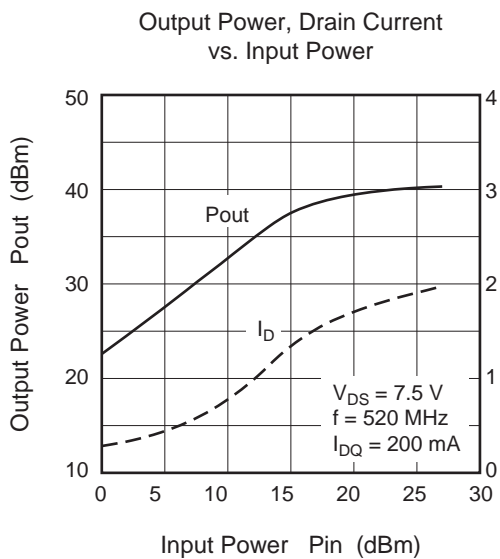

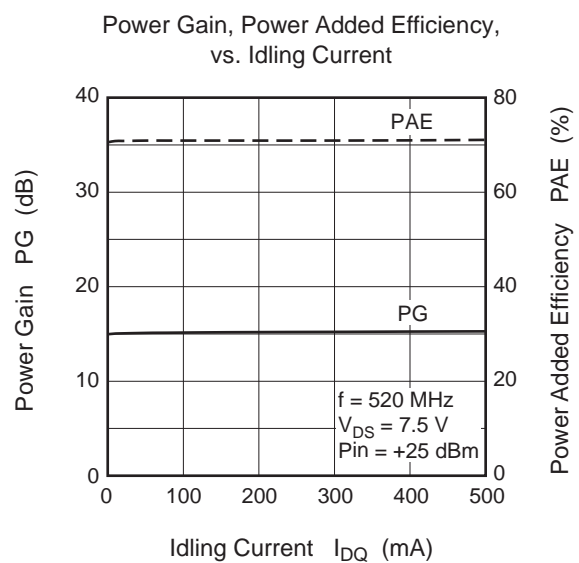
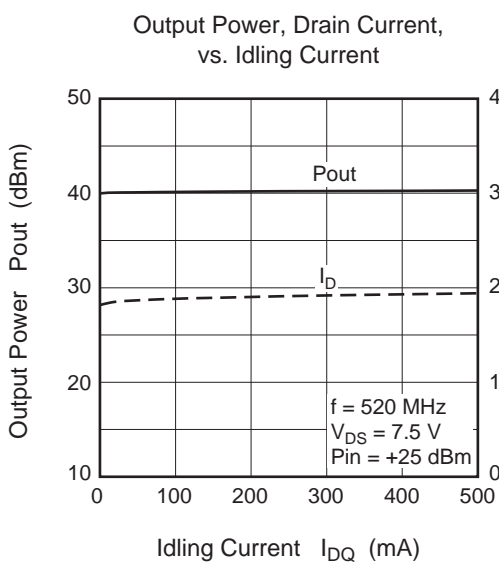
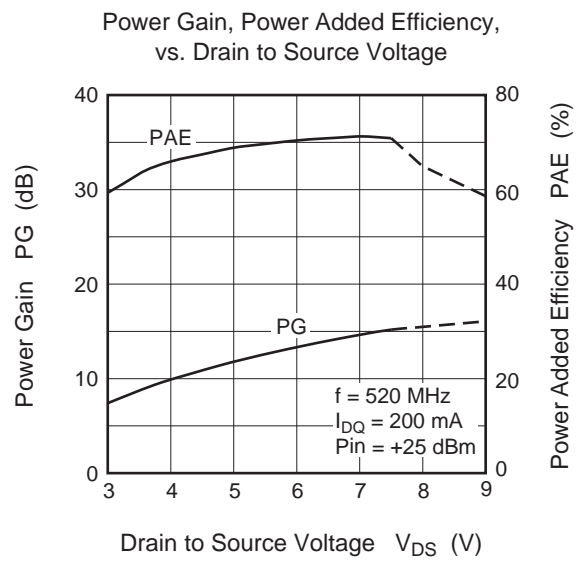
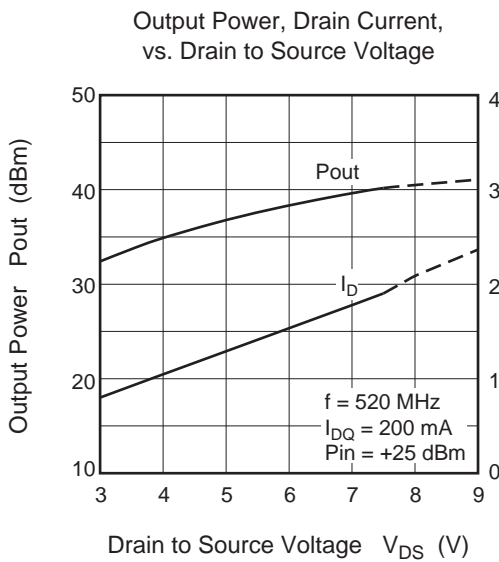
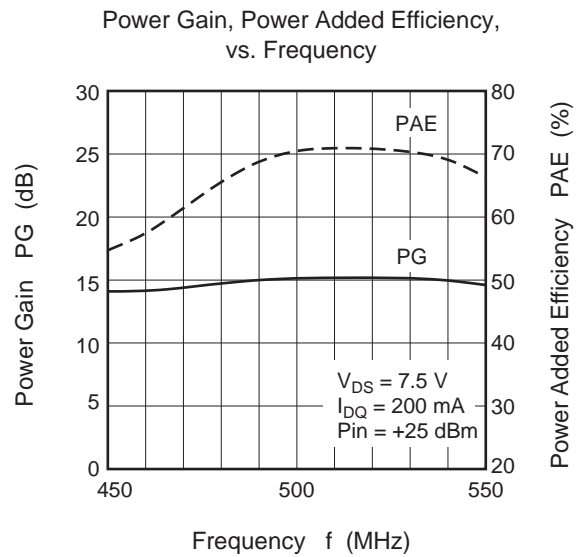
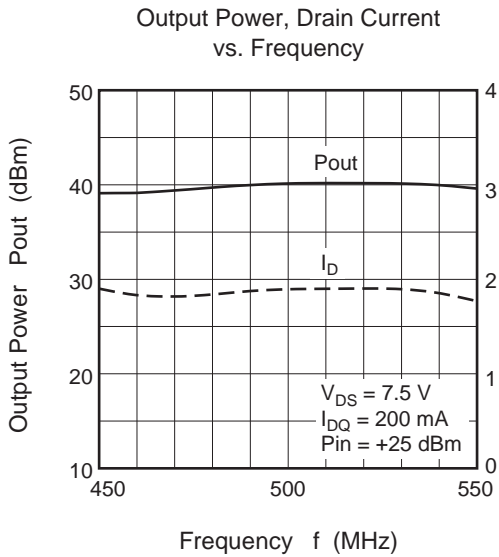

Evaluation Circuit 6 (@ $V_{DD} = 3.7$ V Tuning, $f = 155$ to 162 MHz)

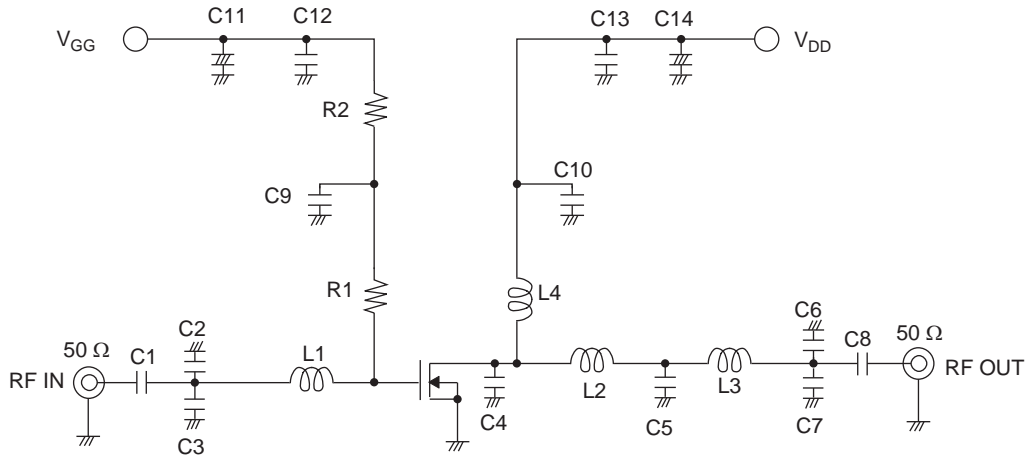

- C1, C2, C4: 10 pF Chip Capacitor
- C3: 18 pF Chip Capacitor
- C5: 22 pF Chip Capacitor
- C6: 4 pF Chip Capacitor
- C7: 47 pF Chip Capacitor
- C8: 27 pF Chip Capacitor
- C9,C10: 100 pF Chip Capacitor
- C12,C13: 1000 pF Chip Capacitor
- C11,C14: 1 μ F /+16V Chip Tantalum Capacitor
- L1: 30 nH Chip Inductor
- L2: 5.6 nH Chip Inductor
- L3: 3.6 nH Chip Inductor
- L4: 8 Turns D : 0.5 mm, ϕ 2.4 mm Enamel Wire
- R1: 33 Ω Chip Resistor
- R2: 6.8 k Ω Chip Resistor

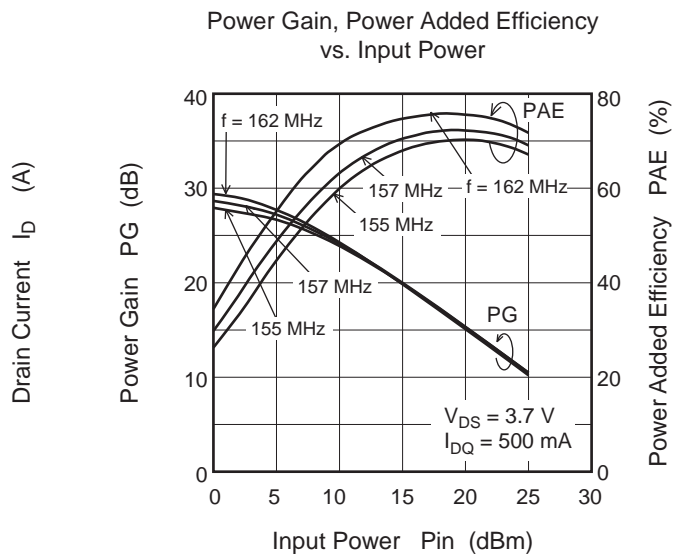
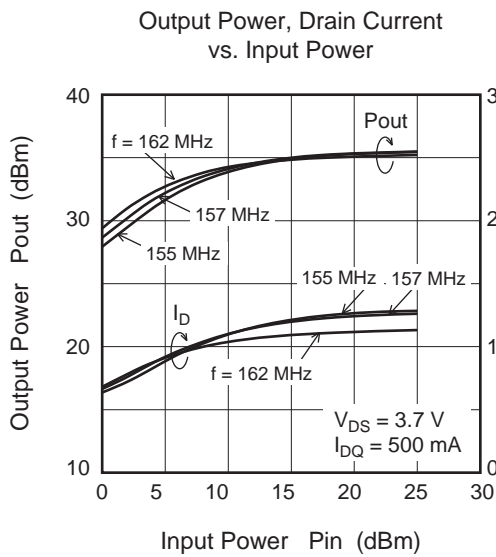

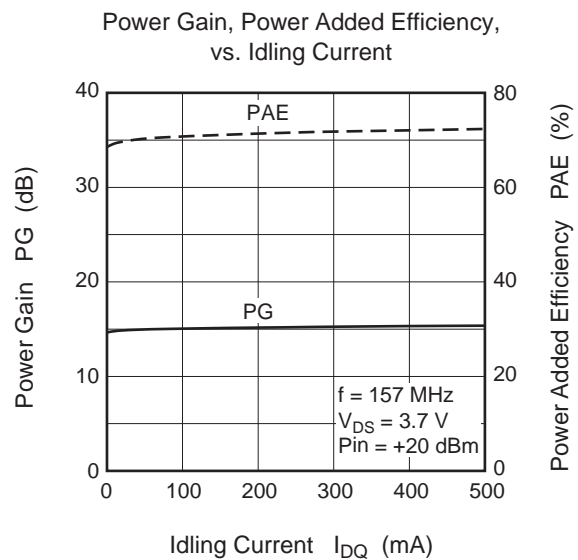
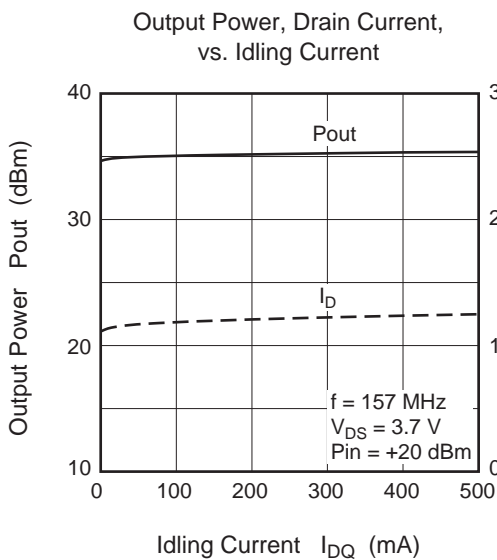
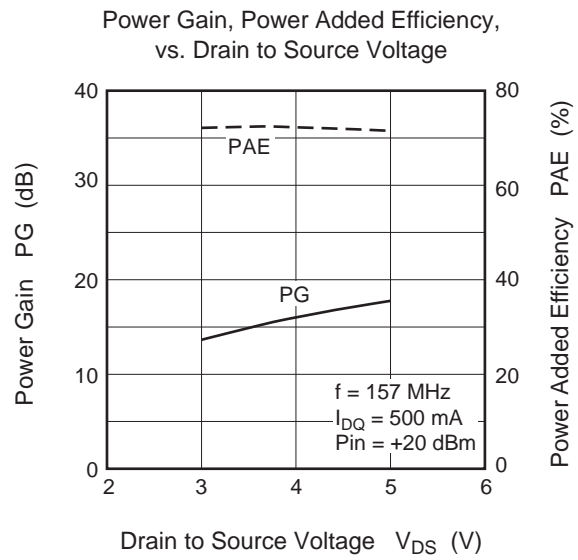
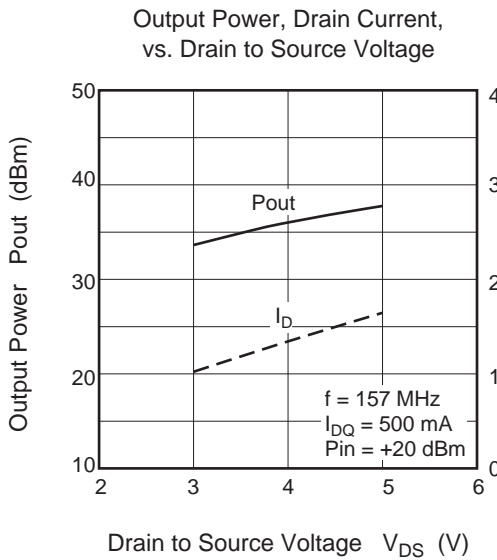
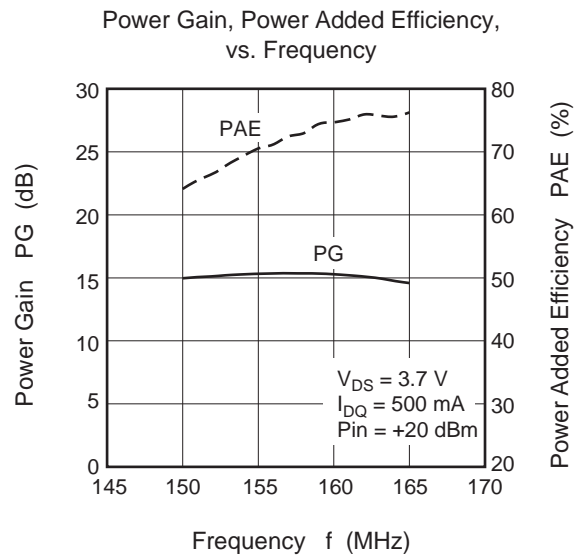
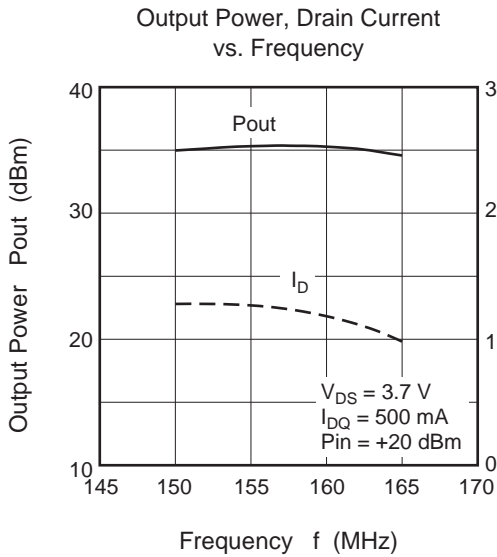

Evaluation Circuit 7 (@V_{DD} = 7.2 V Tuning, f = 360 to 470 MHz)

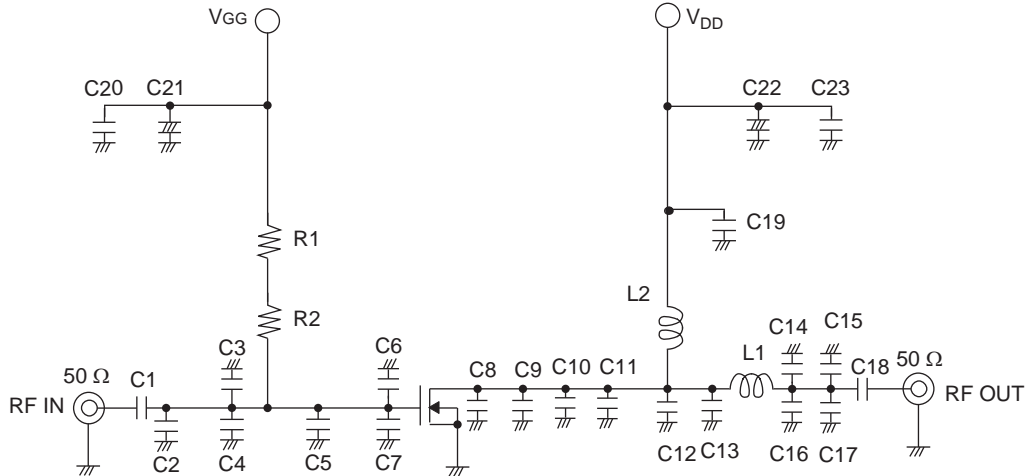

RQA0011

- C1 : 27 pF Chip Capacitor
- C2, C3, C6 : 5 pF Chip Capacitor
- C4: 22 pF Chip Capacitor
- C5, C11 : 10 pF Chip Capacitor
- C7, C12, C13 : 15 pF Chip Capacitor
- C8 : 13 pF Chip Capacitor
- C9, C10 : 24 pF Chip Capacitor
- C14, C17 : 2 pF Chip Capacitor
- C15, C16: 6 pF Chip Capacitor
- C18: 56 pF Chip Capacitor
- C19, C20, C23 : 1000 pF Chip Capacitor
- C21, C22 : 1 μF /+16V Chip Tantalum Capacitor
- L1: 3.6nH Inductor
- L2: 8 Turns D : 0.5 mm, φ2.4 mm Enamel Wire
- R1: 6.8 kΩ Chip Resistor
- R2: 33 Ω Chip Resistor

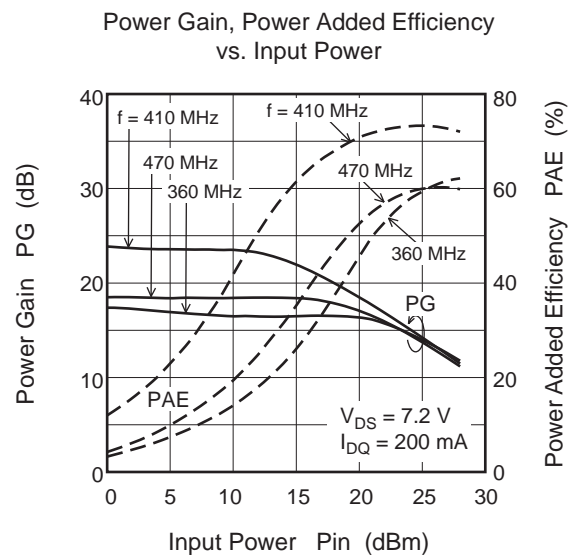
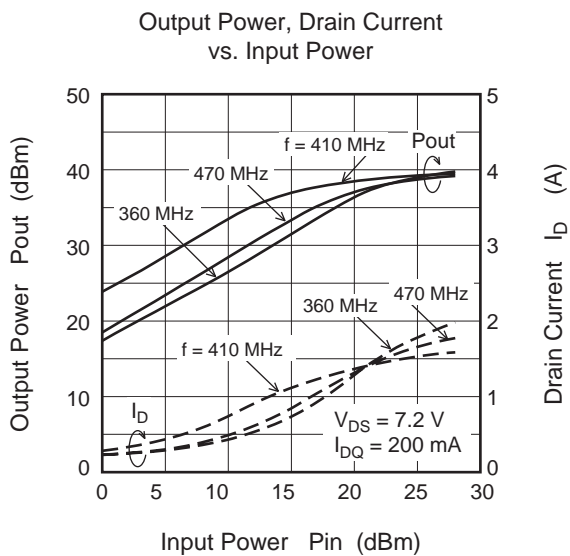

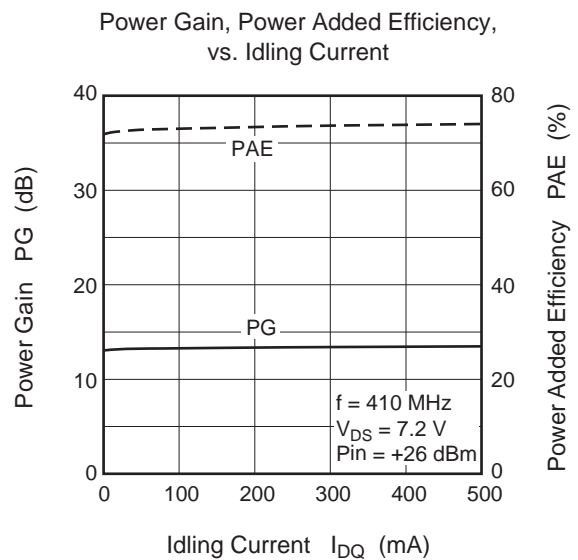
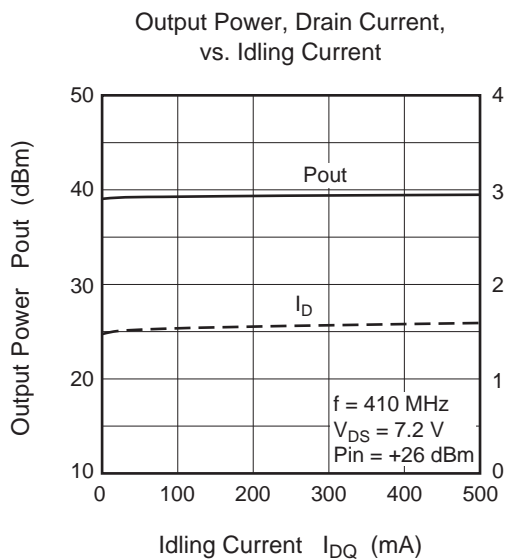
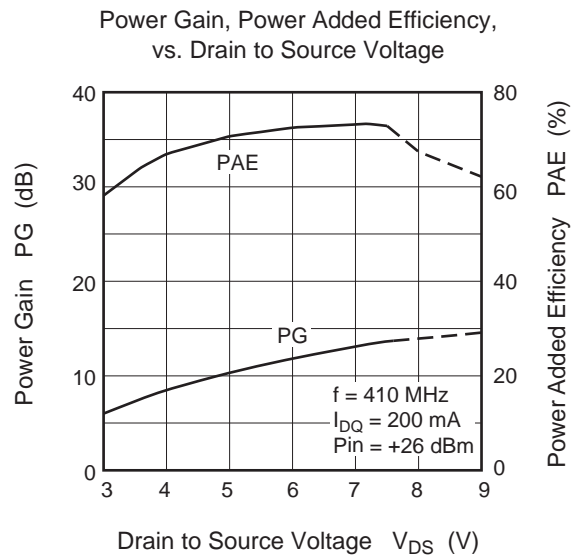
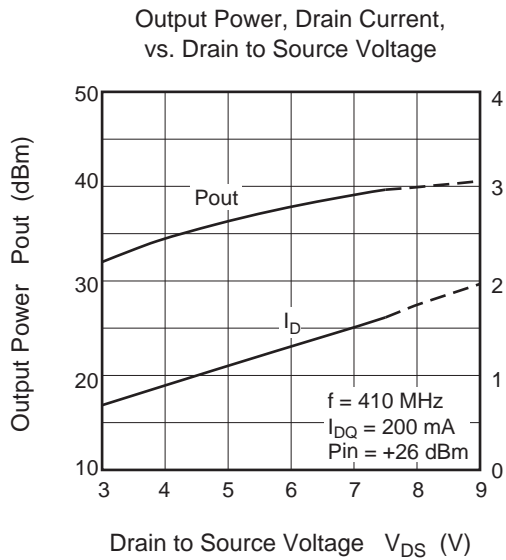
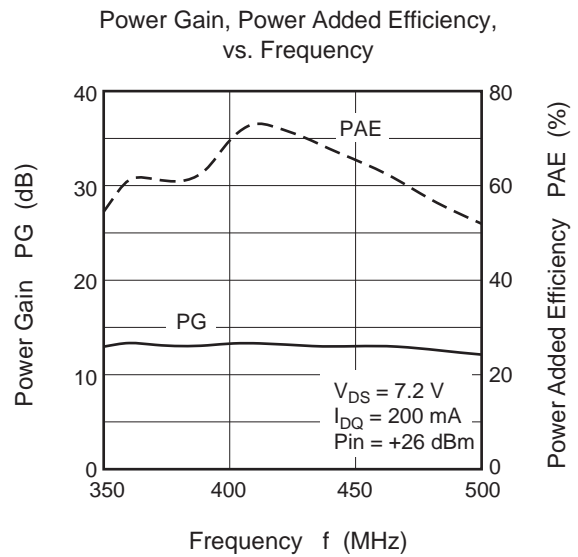
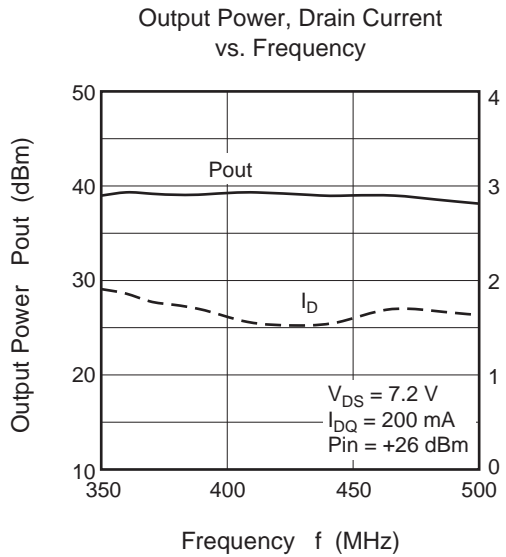

Evaluation Circuit 8 (@V_{DD} = 7.2 V Tuning, f = 400 to 550 MHz)

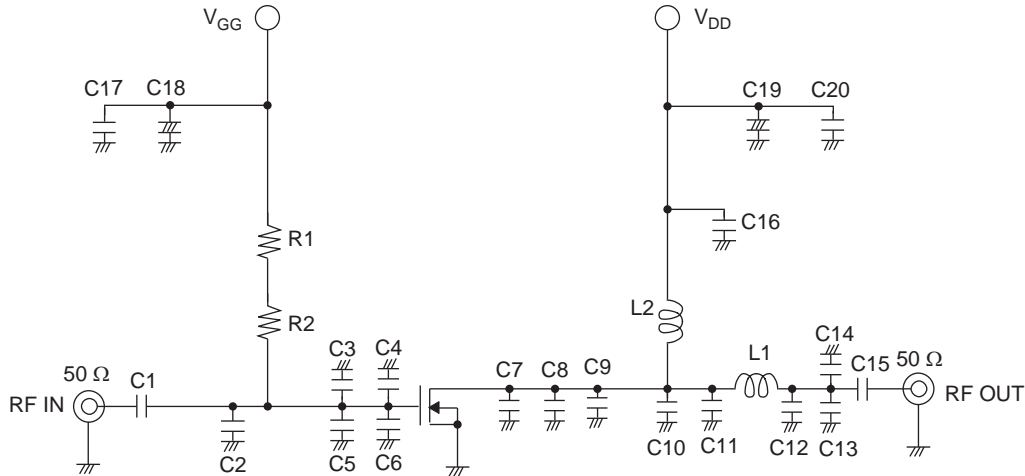

RQA0011

- C1 : 27 pF Chip Capacitor
- C2 : 22 pF Chip Capacitor
- C3, C4: 10 pF Chip Capacitor
- C5 : 4 pF Chip Capacitor
- C6 : 12 pF Chip Capacitor
- C7, C8, C9 : 24 pF Chip Capacitor
- C10, C13 : 5 pF Chip Capacitor
- C11 : 15 pF Chip Capacitor
- C12: 6 pF Chip Capacitor
- C14 : 2 pF Chip Capacitor
- C15 : 56 pF Chip Capacitor
- C16, C17, C20 : 1000 pF Chip Capacitor
- C18, C19 : 1 μF /+16V Chip Tantalum Capacitor
- L1: 3.6nH Inductor
- L2: 8 Turns D : 0.5 mm, φ2.4 mm Enamel Wire
- R1: 6.8 kΩ Chip Resistor
- R2: 33 Ω Chip Resistor

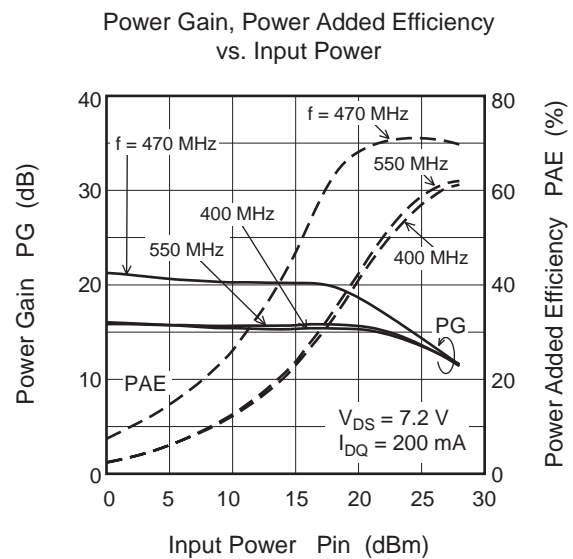
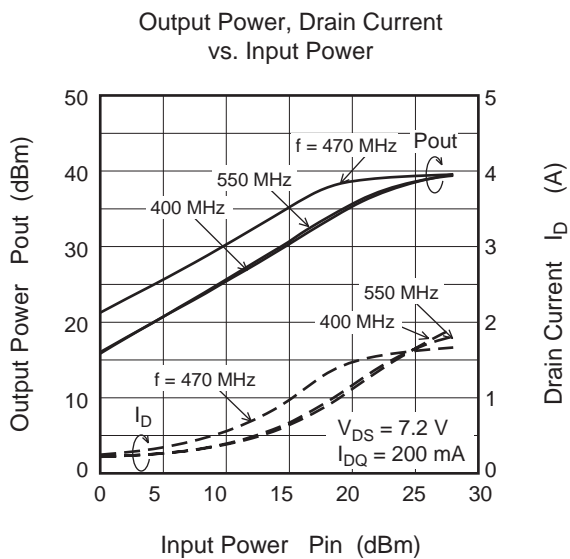

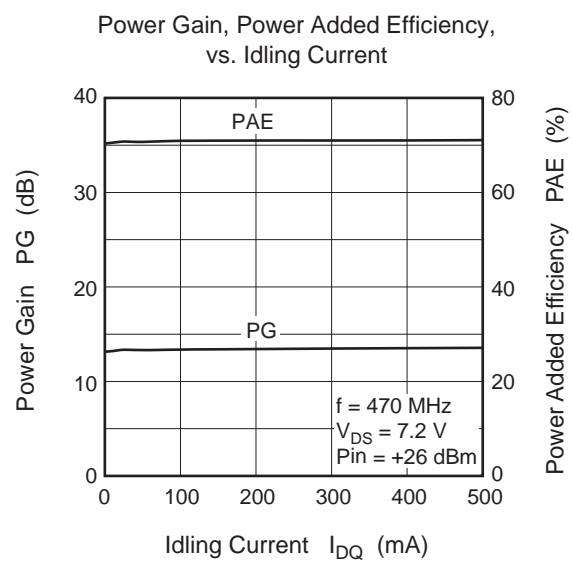
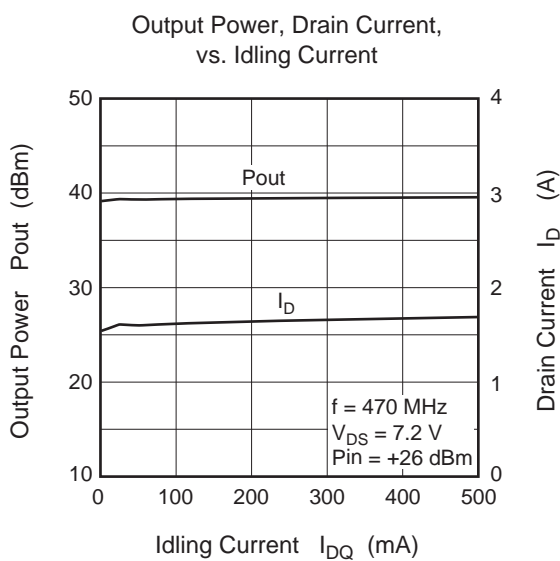
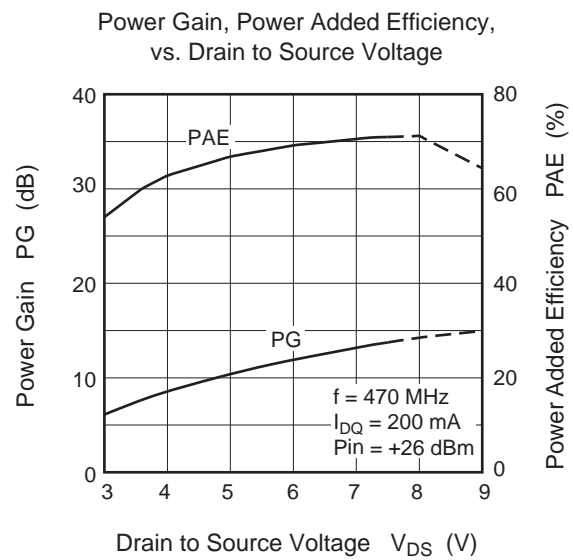
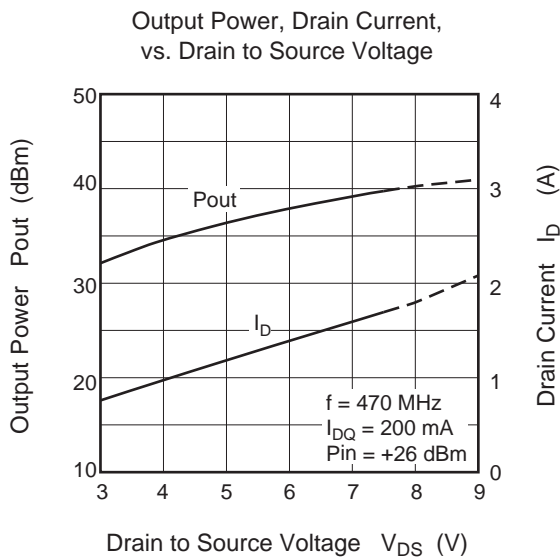
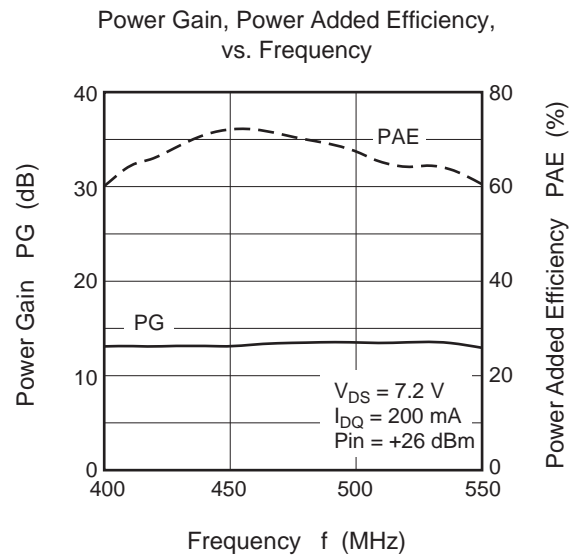
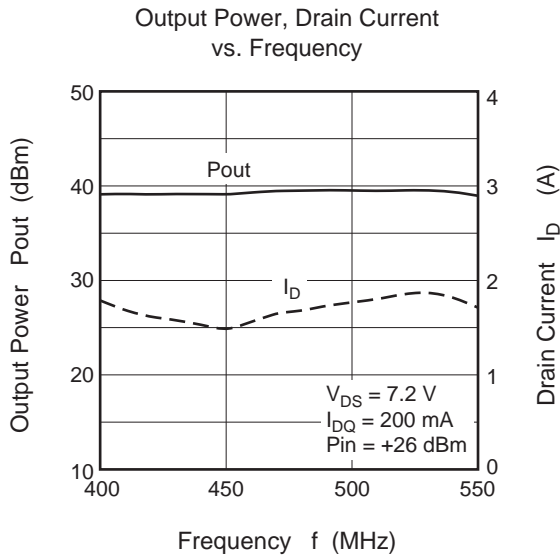

Evaluation Circuit 9 (@V_{DD} = 6.5 V Tuning, f = 350 to 500 MHz, RQA0004 + RQA0011)

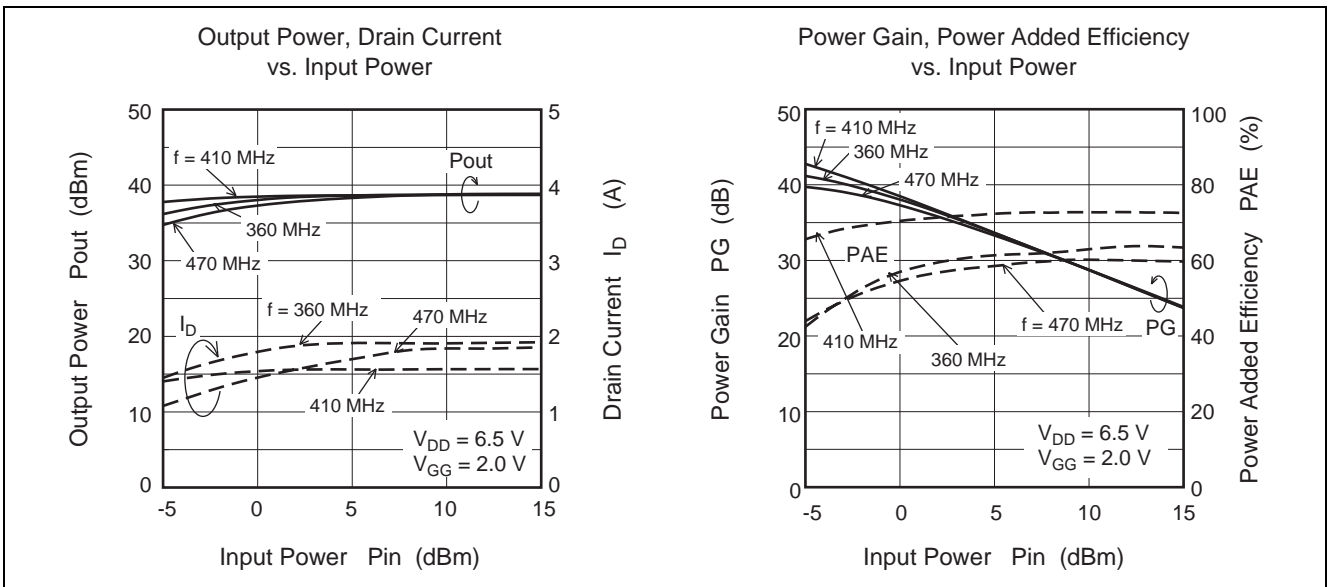
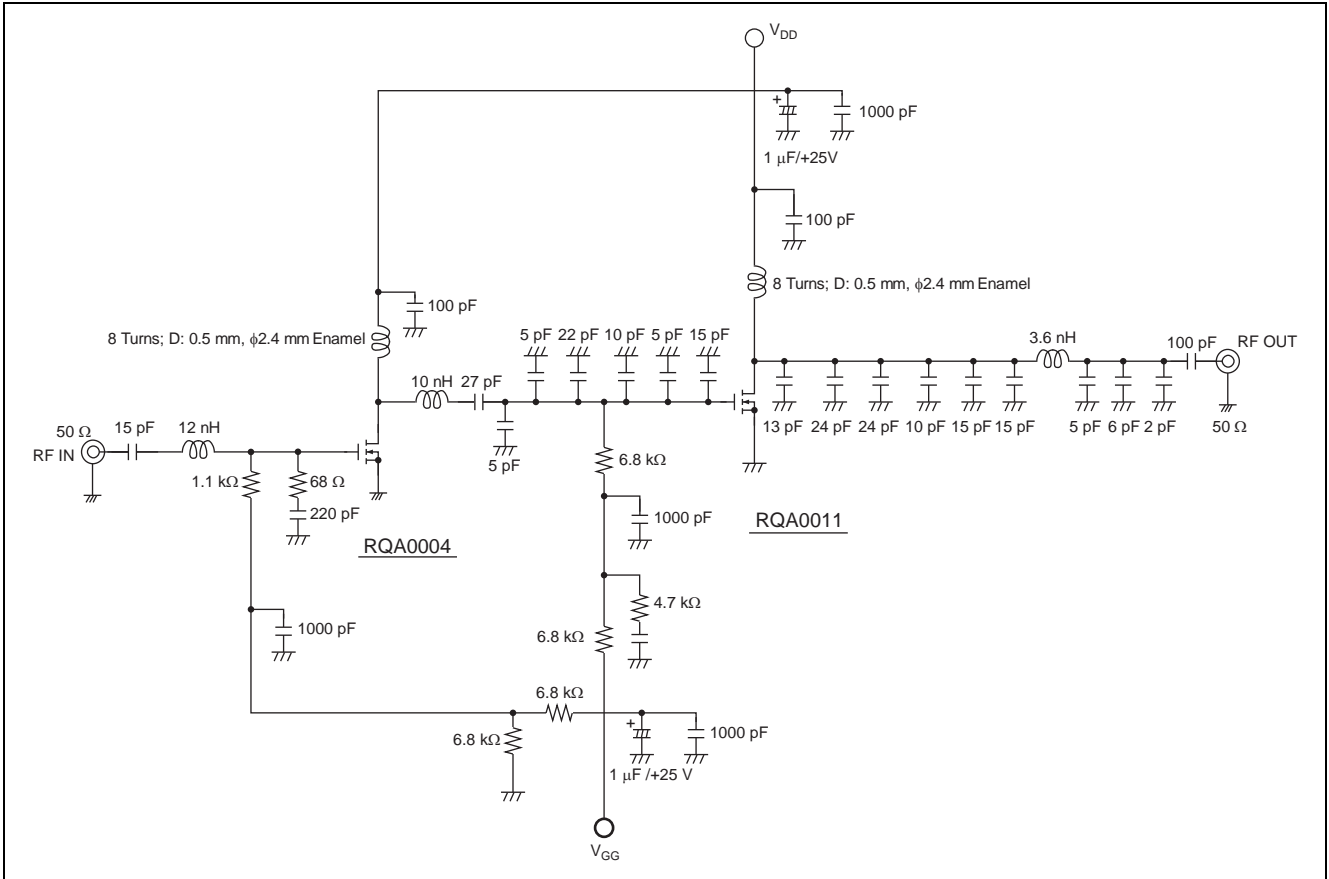

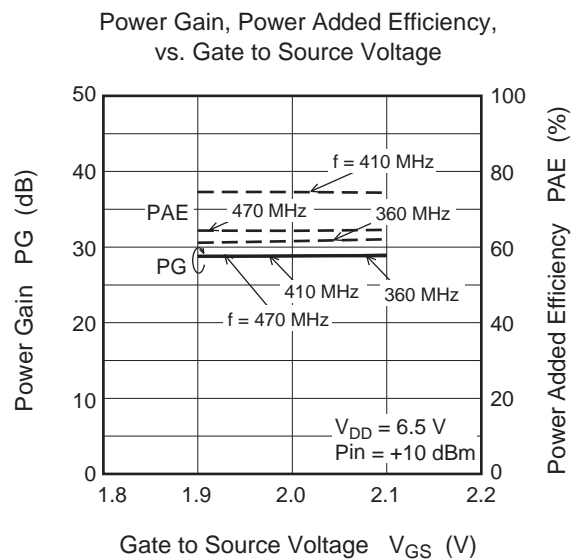
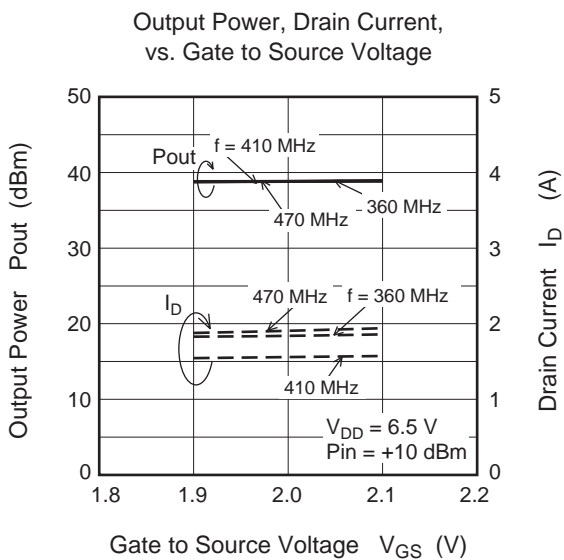
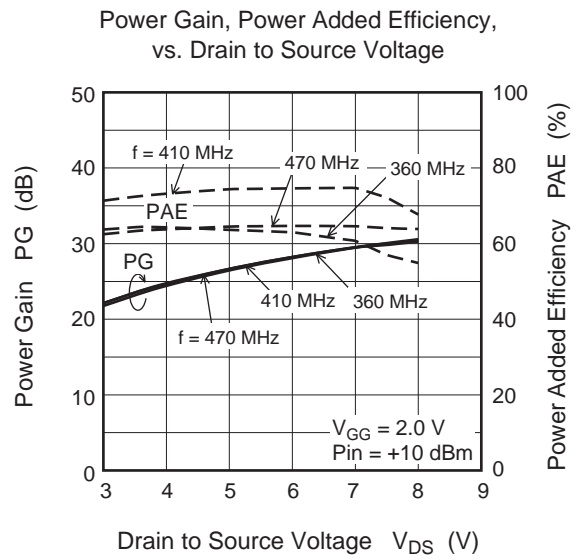
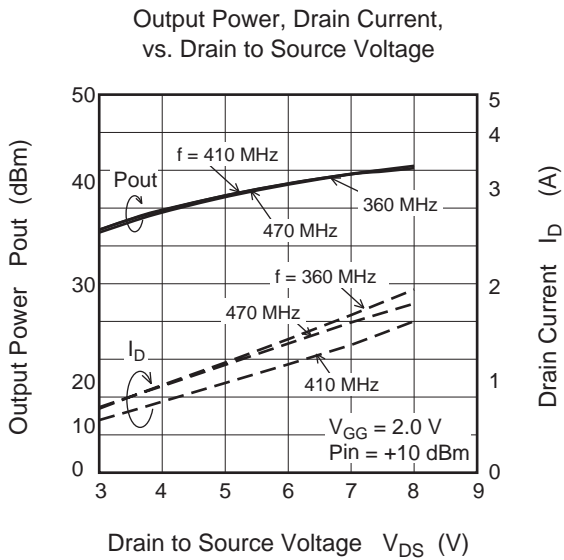
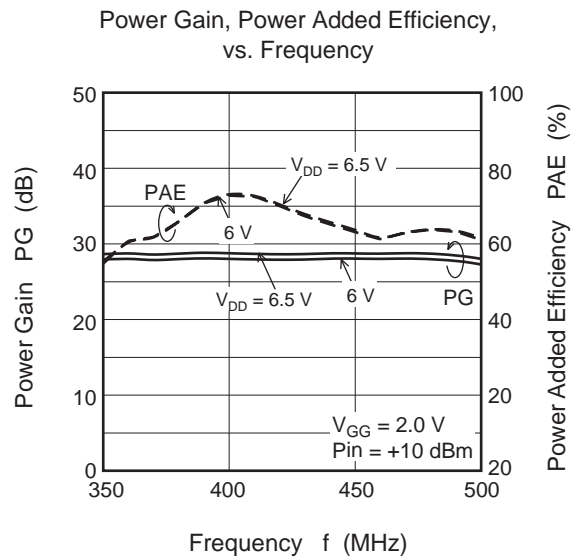
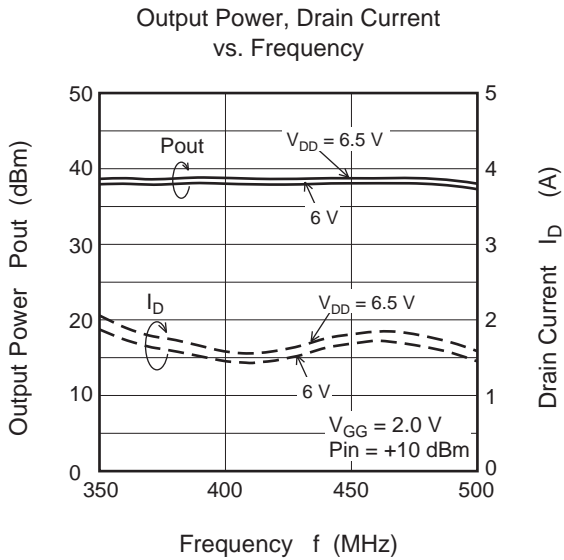

S₁₁ Parameter vs. Frequency

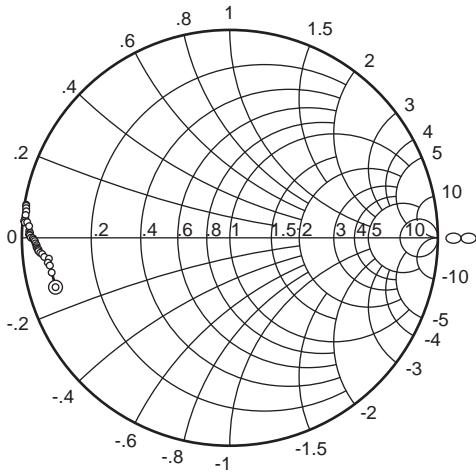

Condition: $V_{DS} = 7.5\text{ V}$, $I_{DQ} = 200\text{ mA}$, $Z_0 = 50\ \Omega$
 100 to 1000 MHz (50 MHz Step)
 1000 to 2500 MHz (100 MHz Step)

S₂₁ Parameter vs. Frequency

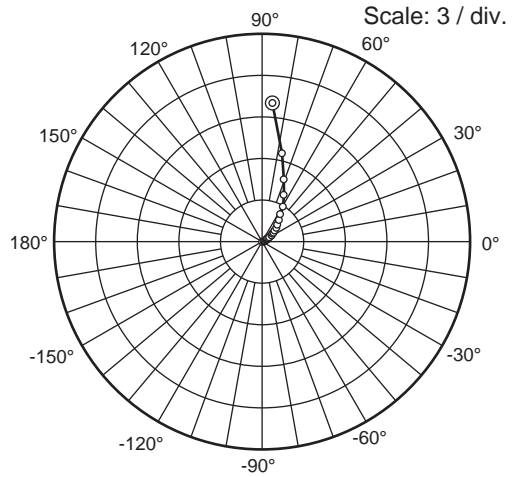

Condition: $V_{DS} = 7.5\text{ V}$, $I_{DQ} = 200\text{ mA}$, $Z_0 = 50\ \Omega$
 100 to 1000 MHz (50 MHz Step)
 1000 to 2500 MHz (100 MHz Step)

S₁₂ Parameter vs. Frequency

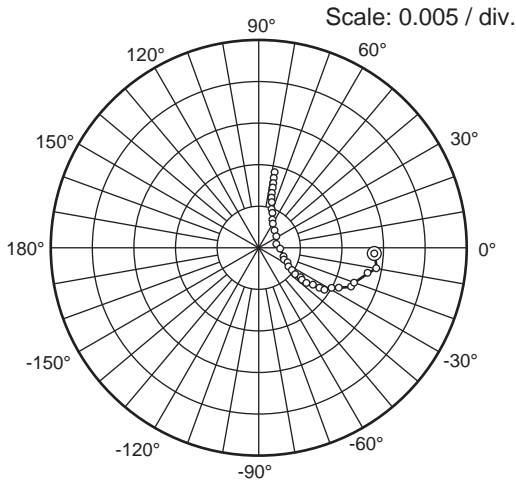

Condition: $V_{DS} = 7.5\text{ V}$, $I_{DQ} = 200\text{ mA}$, $Z_0 = 50\ \Omega$
 100 to 1000 MHz (50 MHz Step)
 1000 to 2500 MHz (100 MHz Step)

S₂₂ Parameter vs. Frequency

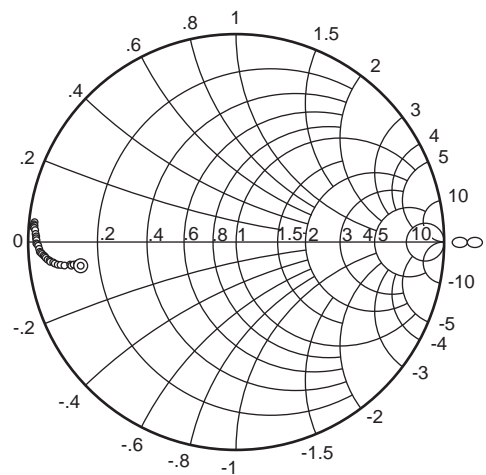

Condition: $V_{DS} = 7.5\text{ V}$, $I_{DQ} = 200\text{ mA}$, $Z_0 = 50\ \Omega$
 100 to 1000 MHz (50 MHz Step)
 1000 to 2500 MHz (100 MHz Step)

S Parameter

 $(V_{DS} = 3.6 \text{ V}, I_D = 200 \text{ mA}, Z_o = 50 \Omega)$

f (MHz)	S11		S21		S12		S22	
	MAG	ANG (deg.)	MAG	ANG (deg.)	MAG	ANG (deg.)	MAG	ANG (deg.)
100	0.861	-166.1	9.02	82.8	0.016	-1.9	0.774	-171.0
150	0.865	-169.7	5.92	74.0	0.016	-13.1	0.788	-171.9
200	0.876	-171.3	4.30	67.4	0.014	-18.3	0.805	-171.8
250	0.883	-172.3	3.29	61.4	0.013	-23.9	0.823	-171.9
300	0.880	-173.1	2.62	56.0	0.013	-27.2	0.824	-172.1
350	0.903	-174.0	2.09	51.4	0.011	-31.8	0.855	-172.4
400	0.915	-174.5	1.72	47.2	0.011	-33.5	0.872	-172.6
450	0.920	-175.0	1.45	43.3	0.010	-38.2	0.886	-172.9
500	0.930	-175.5	1.24	39.8	0.009	-38.5	0.895	-173.4
550	0.935	-176.0	1.06	36.7	0.008	-40.6	0.906	-173.9
600	0.937	-176.4	0.92	33.8	0.007	-41.7	0.914	-174.4
650	0.941	-176.9	0.81	31.2	0.007	-40.9	0.920	-174.7
700	0.941	-177.5	0.71	28.7	0.006	-41.0	0.928	-175.1
750	0.944	-177.9	0.64	26.4	0.005	-41.0	0.934	-175.6
800	0.951	-178.6	0.57	24.4	0.005	-40.3	0.937	-176.0
850	0.952	-179.2	0.51	22.4	0.004	-40.1	0.942	-176.5
900	0.959	-179.6	0.46	21.2	0.004	-33.9	0.945	-177.0
950	0.966	-179.9	0.42	19.8	0.003	-31.0	0.951	-177.3
1000	0.968	-179.8	0.38	18.7	0.003	-25.8	0.954	-177.7
1050	0.969	179.8	0.34	17.5	0.003	-16.0	0.956	-178.0
1100	0.972	179.8	0.32	16.3	0.002	-9.2	0.957	-178.5
1150	0.972	179.7	0.29	15.2	0.002	2.2	0.962	-178.8
1200	0.974	179.4	0.27	14.3	0.002	9.9	0.962	-179.2
1250	0.974	179.2	0.25	13.2	0.002	24.6	0.963	-179.6
1300	0.975	178.9	0.23	12.1	0.002	33.5	0.965	-179.7
1350	0.973	178.6	0.21	11.1	0.002	43.3	0.966	-180.0
1400	0.971	178.2	0.20	9.9	0.003	48.3	0.967	179.8
1450	0.968	177.5	0.19	9.0	0.003	55.8	0.968	179.4
1500	0.970	176.8	0.17	8.0	0.003	62.8	0.967	179.1
1550	0.979	176.5	0.17	7.4	0.004	65.0	0.967	178.9
1600	0.990	175.9	0.16	7.0	0.004	67.1	0.968	178.4
1650	0.995	175.9	0.15	6.9	0.004	68.7	0.968	178.3
1700	0.999	175.8	0.14	6.6	0.004	71.0	0.969	177.9
1750	0.999	175.8	0.13	6.2	0.005	72.3	0.969	177.6
1800	0.999	175.7	0.13	6.2	0.005	74.8	0.972	177.3
1850	0.999	175.7	0.12	6.3	0.005	75.0	0.970	177.0
1900	0.999	175.6	0.12	6.4	0.006	75.5	0.971	176.7
1950	0.999	175.3	0.11	6.4	0.006	75.2	0.972	176.4
2000	0.999	174.9	0.10	6.4	0.006	75.4	0.974	176.2
2050	0.999	174.4	0.10	6.3	0.006	78.5	0.975	175.9
2100	0.999	173.7	0.09	5.9	0.007	78.0	0.975	175.7
2150	0.999	173.0	0.09	5.2	0.007	78.0	0.979	175.5
2200	0.999	172.4	0.09	4.9	0.007	77.6	0.980	175.4
2250	0.999	172.2	0.08	4.2	0.008	78.2	0.979	175.1
2300	0.999	171.5	0.08	4.0	0.008	78.6	0.978	174.9
2350	0.999	171.2	0.08	3.2	0.008	78.8	0.983	174.7
2400	0.999	171.0	0.08	3.3	0.009	79.3	0.979	174.6
2450	0.999	171.2	0.07	2.7	0.009	78.9	0.978	174.4
2500	0.999	170.8	0.07	3.3	0.009	78.7	0.980	174.1

S parameter

 $(V_{DS} = 6\text{ V}, I_D = 200\text{ mA}, Z_o = 50\ \Omega)$

f (MHz)	S11		S21		S12		S22	
	MAG	ANG (deg.)	MAG	ANG (deg.)	MAG	ANG (deg.)	MAG	ANG (deg.)
100	0.869	-165.2	9.86	83.9	0.016	-1.6	0.758	-170.4
150	0.872	-169.3	6.45	75.2	0.015	-10.6	0.773	-171.4
200	0.878	-171.1	4.68	68.4	0.014	-17.0	0.791	-171.3
250	0.887	-172.2	3.59	62.7	0.013	-23.2	0.808	-171.2
300	0.882	-173.2	2.87	57.1	0.012	-26.0	0.811	-171.6
350	0.907	-173.9	2.29	52.6	0.011	-30.3	0.843	-171.7
400	0.915	-174.6	1.90	48.4	0.010	-32.0	0.861	-172.0
450	0.922	-174.9	1.60	44.4	0.009	-36.7	0.874	-172.3
500	0.932	-175.2	1.37	41.1	0.009	-37.5	0.885	-172.9
550	0.933	-175.9	1.18	37.8	0.008	-39.5	0.897	-173.3
600	0.937	-176.4	1.02	35.2	0.007	-40.4	0.905	-173.6
650	0.940	-176.8	0.90	32.5	0.007	-39.4	0.912	-174.0
700	0.941	-177.4	0.79	29.8	0.006	-38.9	0.922	-174.5
750	0.946	-178.0	0.71	27.4	0.005	-40.1	0.927	-174.9
800	0.947	-178.4	0.63	25.1	0.005	-38.9	0.931	-175.4
850	0.955	-179.2	0.57	23.7	0.004	-37.9	0.936	-175.9
900	0.961	-179.8	0.52	21.9	0.004	-32.8	0.941	-176.3
950	0.967	-180.0	0.47	20.6	0.003	-29.5	0.946	-176.7
1000	0.968	-179.9	0.42	19.7	0.003	-26.7	0.949	-177.2
1050	0.969	179.6	0.38	18.3	0.003	-17.2	0.951	-177.6
1100	0.972	179.8	0.35	17.1	0.002	-10.4	0.954	-178.0
1150	0.971	179.7	0.33	15.9	0.002	4.4	0.956	-178.3
1200	0.975	179.5	0.30	15.0	0.002	9.0	0.959	-178.6
1250	0.973	179.3	0.28	14.0	0.002	19.7	0.959	-179.0
1300	0.974	178.9	0.26	12.8	0.002	34.9	0.962	-179.2
1350	0.973	178.8	0.24	11.8	0.002	41.8	0.965	-179.5
1400	0.971	178.3	0.22	10.5	0.003	48.9	0.963	-179.8
1450	0.968	177.7	0.21	9.5	0.003	55.0	0.965	179.9
1500	0.971	177.2	0.20	8.4	0.003	60.4	0.964	179.6
1550	0.975	176.6	0.19	7.8	0.003	63.0	0.966	179.4
1600	0.993	176.1	0.18	7.3	0.004	63.7	0.966	178.9
1650	0.997	175.8	0.17	7.1	0.004	67.9	0.966	178.8
1700	0.999	175.9	0.16	6.7	0.004	69.2	0.967	178.4
1750	0.999	175.8	0.15	6.6	0.004	70.5	0.967	178.0
1800	0.999	175.8	0.14	6.5	0.005	72.7	0.970	177.7
1850	0.999	175.9	0.14	6.4	0.005	74.6	0.969	177.3
1900	0.999	175.9	0.13	6.9	0.006	75.6	0.969	177.1
1950	0.999	175.4	0.12	6.5	0.006	75.6	0.971	176.8
2000	0.999	174.9	0.12	6.3	0.006	76.7	0.972	176.5
2050	0.999	174.6	0.11	6.5	0.006	78.5	0.973	176.3
2100	0.999	173.8	0.11	5.9	0.007	78.2	0.974	176.0
2150	0.999	173.1	0.10	5.0	0.007	77.7	0.978	175.8
2200	0.999	172.6	0.10	4.8	0.007	77.4	0.979	175.8
2250	0.999	172.1	0.09	3.8	0.008	78.2	0.977	175.5
2300	0.999	171.7	0.09	3.4	0.008	77.3	0.978	175.1
2350	0.999	171.2	0.09	2.9	0.008	78.4	0.982	175.1
2400	0.999	171.1	0.08	2.9	0.008	78.9	0.978	174.9
2450	0.999	171.1	0.08	2.5	0.009	78.5	0.978	174.7
2500	0.999	171.1	0.08	2.7	0.009	78.4	0.979	174.4

S parameter

 $(V_{DS} = 7.2 \text{ V}, I_D = 200 \text{ mA}, Z_o = 50 \Omega)$

f (MHz)	S11		S21		S12		S22	
	MAG	ANG (deg.)	MAG	ANG (deg.)	MAG	ANG (deg.)	MAG	ANG (deg.)
100	0.875	-164.1	10.08	85.2	0.015	-0.6	0.757	-170.9
150	0.877	-168.9	6.59	76.3	0.014	-9.4	0.771	-171.7
200	0.884	-170.8	4.78	69.7	0.013	-16.3	0.787	-171.5
250	0.892	-172.0	3.69	63.7	0.012	-20.8	0.804	-171.5
300	0.887	-173.0	2.95	58.3	0.012	-23.6	0.807	-171.7
350	0.908	-173.9	2.35	53.8	0.011	-28.4	0.838	-171.7
400	0.917	-174.4	1.96	49.4	0.010	-30.7	0.854	-172.0
450	0.922	-174.8	1.66	45.8	0.010	-34.6	0.869	-172.3
500	0.931	-175.3	1.42	42.4	0.009	-35.9	0.880	-172.7
550	0.934	-176.0	1.23	39.3	0.008	-38.4	0.893	-173.2
600	0.939	-176.2	1.06	36.3	0.007	-38.5	0.902	-173.6
650	0.943	-176.8	0.93	33.4	0.007	-38.9	0.908	-173.9
700	0.944	-177.4	0.83	31.0	0.006	-36.6	0.917	-174.4
750	0.948	-177.8	0.74	28.4	0.005	-38.0	0.925	-174.8
800	0.949	-178.5	0.66	26.5	0.005	-37.0	0.928	-175.3
850	0.953	-179.1	0.60	24.7	0.004	-36.2	0.933	-175.7
900	0.963	-179.6	0.54	23.3	0.004	-30.7	0.938	-176.2
950	0.972	-179.8	0.50	21.7	0.003	-29.5	0.944	-176.6
1000	0.968	-179.9	0.45	20.3	0.003	-25.6	0.947	-176.9
1050	0.969	180.0	0.41	19.4	0.003	-13.4	0.949	-177.4
1100	0.970	179.8	0.37	18.0	0.002	-7.9	0.953	-177.8
1150	0.972	179.6	0.34	16.8	0.002	3.2	0.955	-178.2
1200	0.975	179.6	0.32	15.8	0.002	8.7	0.958	-178.5
1250	0.975	179.4	0.29	14.8	0.002	24.7	0.958	-178.9
1300	0.977	179.0	0.27	13.5	0.002	33.6	0.960	-179.1
1350	0.972	178.7	0.25	12.4	0.002	43.9	0.962	-179.3
1400	0.972	178.3	0.23	11.2	0.003	45.9	0.963	-179.6
1450	0.967	177.6	0.22	10.0	0.003	53.6	0.963	-180.0
1500	0.971	177.1	0.21	9.0	0.003	61.2	0.963	179.8
1550	0.979	176.6	0.20	8.4	0.003	63.4	0.964	179.5
1600	0.988	176.2	0.19	7.8	0.004	65.1	0.964	179.0
1650	0.996	176.0	0.18	7.6	0.004	68.0	0.965	178.9
1700	0.998	175.7	0.17	7.1	0.004	69.1	0.965	178.5
1750	0.999	175.8	0.16	6.9	0.005	72.3	0.965	178.2
1800	0.999	175.8	0.15	6.8	0.005	72.6	0.969	177.8
1850	0.999	175.9	0.14	6.6	0.005	74.8	0.968	177.5
1900	0.999	175.9	0.14	6.9	0.006	74.8	0.968	177.2
1950	0.999	175.3	0.13	6.6	0.006	76.7	0.970	176.9
2000	0.999	175.0	0.12	6.7	0.006	76.3	0.972	176.7
2050	0.999	174.5	0.12	6.6	0.006	77.7	0.973	176.5
2100	0.999	173.7	0.11	6.2	0.007	76.2	0.974	176.1
2150	0.999	173.1	0.11	5.4	0.007	78.1	0.978	175.9
2200	0.999	172.5	0.10	4.7	0.007	76.9	0.977	175.9
2250	0.999	172.2	0.10	3.9	0.008	78.0	0.977	175.5
2300	0.999	171.7	0.10	3.3	0.008	76.4	0.977	175.2
2350	0.999	171.2	0.09	2.7	0.008	78.6	0.981	175.2
2400	0.999	171.0	0.09	2.7	0.008	79.3	0.978	175.1
2450	0.999	171.1	0.09	2.3	0.009	78.2	0.977	174.8
2500	0.999	170.9	0.08	2.5	0.009	78.6	0.978	174.5

S parameter

 $(V_{DS} = 7.5 \text{ V}, I_D = 50 \text{ mA}, Z_o = 50 \Omega)$

f (MHz)	S11		S21		S12		S22	
	MAG	ANG (deg.)	MAG	ANG (deg.)	MAG	ANG (deg.)	MAG	ANG (deg.)
100	0.823	-154.9	7.70	78.6	0.029	-10.5	0.659	-153.1
150	0.844	-160.8	4.82	66.1	0.027	-23.3	0.715	-156.5
200	0.865	-163.9	3.33	56.7	0.023	-31.6	0.767	-158.5
250	0.887	-166.2	2.44	49.1	0.021	-39.6	0.809	-160.5
300	0.891	-168.1	1.86	42.6	0.019	-44.9	0.829	-162.7
350	0.922	-169.6	1.42	37.5	0.016	-49.4	0.869	-164.4
400	0.932	-171.0	1.14	33.1	0.015	-52.4	0.893	-165.9
450	0.941	-172.0	0.93	29.4	0.013	-56.4	0.908	-167.3
500	0.949	-173.1	0.77	26.1	0.012	-58.1	0.920	-168.6
550	0.953	-173.8	0.65	23.5	0.011	-59.9	0.931	-169.7
600	0.955	-174.4	0.54	21.0	0.009	-61.1	0.939	-170.7
650	0.955	-175.4	0.47	18.8	0.008	-62.3	0.944	-171.6
700	0.957	-176.2	0.41	16.6	0.007	-61.7	0.950	-172.3
750	0.965	-176.8	0.36	14.7	0.007	-62.9	0.955	-173.1
800	0.962	-177.6	0.32	13.1	0.006	-62.2	0.958	-173.8
850	0.969	-178.3	0.28	11.5	0.005	-63.0	0.961	-174.5
900	0.973	-178.8	0.26	10.9	0.004	-60.5	0.963	-175.1
950	0.979	-179.3	0.23	9.6	0.004	-58.6	0.967	-175.6
1000	0.977	-179.2	0.21	8.9	0.003	-57.6	0.969	-176.2
1050	0.982	-179.7	0.19	7.9	0.002	-53.5	0.969	-176.7
1100	0.984	180.0	0.17	7.2	0.002	-46.6	0.971	-177.2
1150	0.982	179.7	0.16	6.3	0.002	-38.0	0.973	-177.5
1200	0.982	179.6	0.15	5.8	0.001	-27.7	0.975	-177.9
1250	0.983	179.5	0.13	5.1	0.001	-1.9	0.975	-178.4
1300	0.984	179.1	0.12	4.2	0.001	21.6	0.976	-178.6
1350	0.986	178.9	0.12	3.5	0.001	37.7	0.977	-178.9
1400	0.987	178.6	0.11	2.9	0.002	47.3	0.978	-179.2
1450	0.987	177.9	0.10	2.2	0.002	56.0	0.977	-179.6
1500	0.989	177.1	0.09	1.4	0.002	64.7	0.976	180.0
1550	0.989	176.5	0.09	0.8	0.003	69.3	0.977	179.7
1600	0.989	175.9	0.08	0.9	0.003	71.4	0.977	179.3
1650	0.999	175.8	0.08	1.3	0.003	73.5	0.976	179.2
1700	0.999	175.8	0.08	1.0	0.004	74.6	0.976	178.7
1750	0.999	176.0	0.07	1.2	0.004	75.2	0.976	178.4
1800	0.999	175.9	0.07	1.9	0.004	76.6	0.978	178.1
1850	0.999	175.8	0.06	1.9	0.005	78.8	0.978	177.7
1900	0.999	175.7	0.06	3.0	0.005	78.7	0.977	177.3
1950	0.999	175.4	0.06	3.1	0.005	79.7	0.980	177.1
2000	0.999	174.9	0.06	3.4	0.006	79.1	0.981	176.8
2050	0.999	174.6	0.05	3.5	0.006	81.0	0.982	176.6
2100	0.999	174.2	0.05	3.6	0.006	80.3	0.982	176.3
2150	0.999	173.6	0.05	3.2	0.007	80.9	0.986	176.1
2200	0.999	173.0	0.05	3.0	0.007	80.5	0.985	176.0
2250	0.999	172.8	0.04	3.0	0.007	80.7	0.985	175.7
2300	0.999	172.1	0.04	3.0	0.007	80.5	0.984	175.4
2350	0.999	171.6	0.04	3.4	0.008	81.6	0.988	175.2
2400	0.999	171.6	0.04	3.7	0.008	81.2	0.985	175.2
2450	0.999	171.6	0.04	3.8	0.008	80.7	0.984	174.9
2500	0.999	171.4	0.04	4.6	0.009	80.5	0.985	174.6

S parameter

(V_{DS} = 7.5 V, I_D = 100 mA, Z_o = 50 Ω)

f (MHz)	S11		S21		S12		S22	
	MAG	ANG (deg.)	MAG	ANG (deg.)	MAG	ANG (deg.)	MAG	ANG (deg.)
100	0.844	-161.0	9.17	82.5	0.020	-3.8	0.702	-165.1
150	0.855	-165.9	5.87	72.1	0.019	-16.1	0.731	-166.4
200	0.867	-168.1	4.19	64.4	0.017	-22.8	0.760	-166.6
250	0.880	-169.6	3.17	57.7	0.017	-29.0	0.789	-166.9
300	0.880	-170.8	2.49	51.8	0.015	-31.9	0.802	-167.7
350	0.906	-172.0	1.96	46.7	0.014	-37.6	0.840	-168.3
400	0.913	-172.7	1.60	42.2	0.012	-40.1	0.862	-169.1
450	0.925	-173.5	1.33	38.4	0.011	-44.6	0.878	-169.8
500	0.932	-174.4	1.12	35.1	0.010	-45.7	0.892	-170.5
550	0.939	-175.0	0.96	31.9	0.009	-49.7	0.903	-171.4
600	0.944	-175.4	0.83	29.3	0.008	-50.1	0.912	-172.1
650	0.944	-176.1	0.72	26.6	0.007	-50.3	0.919	-172.7
700	0.946	-176.9	0.63	24.2	0.007	-50.0	0.928	-173.3
750	0.951	-177.4	0.56	22.0	0.006	-50.8	0.934	-173.8
800	0.952	-178.1	0.49	20.0	0.005	-50.0	0.937	-174.4
850	0.958	-178.9	0.44	18.5	0.004	-50.1	0.941	-174.9
900	0.961	-179.2	0.40	17.3	0.004	-44.7	0.947	-175.5
950	0.967	-179.3	0.36	16.0	0.003	-44.2	0.951	-175.9
1000	0.971	-179.7	0.33	15.0	0.003	-42.4	0.954	-176.5
1050	0.969	-180.0	0.30	13.9	0.002	-35.6	0.957	-177.0
1100	0.972	179.7	0.27	12.7	0.002	-27.0	0.959	-177.5
1150	0.976	179.7	0.25	11.6	0.002	-15.0	0.961	-177.7
1200	0.976	179.5	0.23	11.0	0.002	-6.4	0.963	-178.2
1250	0.978	179.1	0.21	9.7	0.002	10.7	0.963	-178.6
1300	0.976	179.1	0.20	9.0	0.002	21.9	0.965	-178.8
1350	0.979	178.7	0.18	8.0	0.002	37.1	0.966	-179.1
1400	0.980	178.3	0.17	7.0	0.002	45.3	0.966	-179.3
1450	0.982	177.7	0.16	5.9	0.002	53.3	0.967	-179.8
1500	0.983	177.0	0.15	4.9	0.003	61.1	0.967	180.0
1550	0.984	176.4	0.14	4.3	0.003	64.9	0.968	179.7
1600	0.985	175.8	0.13	4.1	0.003	66.4	0.969	179.2
1650	0.999	175.9	0.13	4.2	0.004	67.9	0.969	179.1
1700	0.999	175.6	0.12	3.7	0.004	69.8	0.969	178.7
1750	0.999	175.9	0.12	3.9	0.004	73.2	0.970	178.3
1800	0.999	175.7	0.11	3.8	0.004	72.8	0.972	178.0
1850	0.999	175.7	0.10	4.0	0.005	75.9	0.970	177.7
1900	0.999	175.8	0.10	4.5	0.005	76.8	0.971	177.2
1950	0.999	175.3	0.09	4.5	0.006	76.8	0.973	177.0
2000	0.999	174.9	0.09	4.2	0.006	77.5	0.974	176.8
2050	0.999	174.6	0.08	4.7	0.006	79.9	0.973	176.6
2100	0.999	174.0	0.08	4.2	0.007	77.7	0.975	176.3
2150	0.999	173.4	0.08	3.6	0.007	79.2	0.979	176.0
2200	0.999	172.8	0.07	2.8	0.007	79.7	0.979	176.0
2250	0.999	172.6	0.07	2.6	0.007	79.0	0.979	175.7
2300	0.999	172.0	0.07	2.4	0.008	79.0	0.979	175.4
2350	0.999	171.4	0.07	2.0	0.008	79.9	0.983	175.3
2400	0.999	171.3	0.06	1.9	0.008	80.2	0.978	175.1
2450	0.999	171.3	0.06	1.8	0.008	79.5	0.979	174.8
2500	0.999	171.3	0.06	2.3	0.009	79.2	0.980	174.6

S parameter

 $(V_{DS} = 7.5 \text{ V}, I_D = 200 \text{ mA}, Z_o = 50 \Omega)$

f (MHz)	S11		S21		S12		S22	
	MAG	ANG (deg.)	MAG	ANG (deg.)	MAG	ANG (deg.)	MAG	ANG (deg.)
100	0.879	-164.2	10.01	85.5	0.014	-3.4	0.758	-171.4
150	0.880	-168.9	6.55	77.0	0.014	-10.6	0.773	-172.1
200	0.884	-170.9	4.75	70.5	0.013	-13.8	0.787	-172.0
250	0.893	-172.1	3.69	64.7	0.012	-20.8	0.803	-171.8
300	0.884	-173.3	2.95	59.3	0.012	-23.7	0.805	-172.0
350	0.906	-173.9	2.37	54.9	0.011	-27.5	0.835	-172.1
400	0.913	-174.8	1.97	50.7	0.010	-29.4	0.852	-172.4
450	0.922	-175.3	1.67	46.9	0.009	-33.1	0.866	-172.6
500	0.931	-175.7	1.43	43.5	0.009	-34.6	0.878	-173.0
550	0.932	-176.0	1.24	40.3	0.008	-35.6	0.887	-173.4
600	0.935	-176.4	1.08	37.4	0.007	-37.2	0.897	-173.7
650	0.938	-177.0	0.95	34.6	0.007	-38.0	0.903	-174.1
700	0.939	-177.7	0.84	32.1	0.006	-36.3	0.913	-174.5
750	0.944	-178.2	0.75	29.5	0.005	-37.3	0.919	-175.0
800	0.946	-178.6	0.67	27.7	0.005	-35.8	0.923	-175.4
850	0.953	-179.3	0.61	25.8	0.004	-34.3	0.929	-175.7
900	0.957	-179.7	0.55	24.0	0.004	-28.9	0.934	-176.2
950	0.964	-180.0	0.50	22.6	0.003	-27.9	0.939	-176.6
1000	0.965	-180.0	0.46	21.5	0.003	-22.4	0.943	-176.9
1050	0.969	179.5	0.42	20.0	0.003	-14.2	0.945	-177.4
1100	0.969	179.6	0.38	18.6	0.002	-7.2	0.949	-177.9
1150	0.968	179.3	0.35	17.4	0.002	5.2	0.951	-178.2
1200	0.973	179.3	0.32	16.6	0.002	8.9	0.954	-178.6
1250	0.972	178.7	0.30	15.0	0.002	24.2	0.954	-179.0
1300	0.972	178.8	0.28	14.1	0.002	31.9	0.957	-179.1
1350	0.971	178.7	0.26	13.1	0.002	41.1	0.959	-179.4
1400	0.975	178.1	0.24	11.9	0.003	46.9	0.959	-179.6
1450	0.974	177.7	0.22	10.6	0.003	51.3	0.959	-180.0
1500	0.975	177.0	0.21	9.4	0.003	59.2	0.961	179.7
1550	0.978	176.5	0.20	9.0	0.003	61.8	0.961	179.5
1600	0.984	175.8	0.19	8.4	0.004	63.3	0.962	179.1
1650	0.990	175.8	0.18	8.1	0.004	67.9	0.962	178.9
1700	0.995	175.5	0.17	7.6	0.004	68.4	0.963	178.5
1750	0.998	175.8	0.16	7.4	0.005	71.3	0.964	178.2
1800	0.999	176.0	0.16	7.3	0.005	71.6	0.967	177.8
1850	0.999	175.7	0.15	7.1	0.005	74.7	0.966	177.5
1900	0.999	175.6	0.14	7.3	0.005	74.8	0.965	177.2
1950	0.999	175.3	0.13	7.2	0.006	75.1	0.967	176.9
2000	0.999	174.8	0.13	7.0	0.006	75.7	0.969	176.7
2050	0.999	174.3	0.12	7.0	0.006	78.5	0.969	176.5
2100	0.999	173.8	0.12	6.4	0.007	76.6	0.971	176.2
2150	0.999	173.3	0.11	5.6	0.007	77.1	0.974	176.0
2200	0.999	172.6	0.11	4.9	0.007	77.0	0.975	175.9
2250	0.999	172.2	0.10	4.1	0.008	77.6	0.974	175.6
2300	0.999	171.8	0.10	3.4	0.008	77.3	0.976	175.3
2350	0.999	171.3	0.09	3.0	0.008	78.4	0.980	175.2
2400	0.999	171.4	0.09	3.1	0.008	78.5	0.977	175.1
2450	0.999	171.3	0.09	2.9	0.009	78.4	0.977	174.8
2500	0.999	171.2	0.09	2.9	0.009	78.8	0.977	174.5

S parameter

 $(V_{DS} = 7.5 \text{ V}, I_D = 300 \text{ mA}, Z_o = 50 \Omega)$

f (MHz)	S11		S21		S12		S22	
	MAG	ANG (deg.)	MAG	ANG (deg.)	MAG	ANG (deg.)	MAG	ANG (deg.)
100	0.896	-165.0	10.25	87.2	0.013	3.4	0.785	-173.3
150	0.892	-169.8	6.73	79.1	0.012	-4.6	0.795	-174.1
200	0.895	-171.6	4.94	73.2	0.011	-10.3	0.805	-173.9
250	0.901	-173.1	3.85	67.9	0.011	-16.0	0.816	-173.7
300	0.891	-174.1	3.11	62.9	0.011	-18.7	0.814	-173.8
350	0.912	-175.0	2.51	58.5	0.010	-22.0	0.840	-173.7
400	0.918	-175.1	2.11	54.8	0.009	-23.4	0.855	-173.9
450	0.924	-175.8	1.80	50.9	0.009	-27.0	0.865	-174.0
500	0.933	-176.3	1.56	47.5	0.008	-28.2	0.875	-174.2
550	0.931	-176.7	1.35	44.3	0.007	-29.4	0.885	-174.5
600	0.932	-176.9	1.19	41.5	0.007	-30.5	0.893	-174.7
650	0.937	-177.5	1.05	38.8	0.006	-29.9	0.899	-175.0
700	0.936	-178.0	0.93	35.8	0.006	-27.9	0.907	-175.3
750	0.938	-178.4	0.84	33.6	0.005	-28.5	0.914	-175.7
800	0.945	-179.0	0.75	31.4	0.005	-26.9	0.918	-175.9
850	0.948	-179.7	0.69	29.3	0.004	-26.6	0.924	-176.4
900	0.953	180.0	0.63	27.5	0.004	-20.4	0.929	-176.6
950	0.961	179.8	0.57	26.0	0.003	-16.5	0.935	-177.0
1000	0.963	179.9	0.52	25.0	0.003	-14.1	0.938	-177.4
1050	0.966	179.6	0.48	23.1	0.003	-5.8	0.940	-177.8
1100	0.966	179.3	0.44	21.9	0.003	3.2	0.944	-178.2
1150	0.966	179.3	0.41	20.8	0.003	11.0	0.948	-178.4
1200	0.967	179.2	0.37	19.6	0.002	15.9	0.949	-178.8
1250	0.969	179.0	0.34	18.3	0.003	26.3	0.950	-179.2
1300	0.970	178.7	0.32	17.1	0.003	33.7	0.953	-179.3
1350	0.972	178.4	0.30	15.8	0.003	44.4	0.954	-179.6
1400	0.976	178.2	0.28	14.5	0.003	49.3	0.955	-179.8
1450	0.974	177.4	0.26	13.4	0.003	52.7	0.956	179.9
1500	0.974	176.8	0.24	12.1	0.004	59.3	0.956	179.6
1550	0.980	176.3	0.23	11.5	0.004	62.8	0.959	179.4
1600	0.985	175.8	0.22	10.8	0.004	63.8	0.959	178.9
1650	0.997	175.7	0.21	10.3	0.004	66.1	0.959	178.8
1700	0.999	175.7	0.20	10.0	0.005	68.4	0.960	178.4
1750	0.999	175.7	0.19	9.7	0.005	69.6	0.961	178.1
1800	0.999	175.6	0.18	9.3	0.005	69.4	0.964	177.7
1850	0.999	175.7	0.17	9.0	0.005	70.8	0.962	177.4
1900	0.999	175.5	0.16	9.2	0.006	72.8	0.963	177.1
1950	0.999	175.2	0.16	9.0	0.006	74.1	0.965	176.8
2000	0.999	174.7	0.15	8.8	0.006	74.9	0.966	176.6
2050	0.999	174.3	0.14	8.6	0.007	76.4	0.967	176.4
2100	0.999	173.7	0.13	8.0	0.007	75.7	0.969	176.1
2150	0.999	173.1	0.13	7.2	0.007	77.2	0.972	175.9
2200	0.999	172.5	0.12	6.4	0.007	77.1	0.972	175.8
2250	0.999	172.1	0.12	5.5	0.008	77.9	0.972	175.5
2300	0.999	171.6	0.11	5.0	0.008	76.4	0.973	175.3
2350	0.999	171.2	0.11	4.1	0.008	78.3	0.977	175.1
2400	0.999	171.1	0.11	4.1	0.009	78.1	0.974	175.0
2450	0.999	171.1	0.10	3.6	0.009	78.3	0.974	174.7
2500	0.999	171.0	0.10	3.7	0.009	78.3	0.974	174.4

S parameter

 $(V_{DS} = 7.5 \text{ V}, I_D = 400 \text{ mA}, Z_o = 50 \Omega)$

f (MHz)	S11		S21		S12		S22	
	MAG	ANG (deg.)	MAG	ANG (deg.)	MAG	ANG (deg.)	MAG	ANG (deg.)
100	0.903	-165.5	10.28	88.0	0.013	4.2	0.799	-174.4
150	0.903	-170.2	6.78	80.2	0.011	-6.6	0.808	-175.1
200	0.901	-172.3	4.99	74.6	0.010	-9.4	0.816	-174.9
250	0.907	-173.5	3.91	69.6	0.010	-13.8	0.826	-174.7
300	0.895	-174.7	3.17	64.6	0.010	-15.9	0.821	-174.8
350	0.916	-175.4	2.58	60.6	0.009	-20.6	0.847	-174.9
400	0.922	-175.8	2.17	56.7	0.008	-20.5	0.859	-174.7
450	0.927	-176.2	1.86	53.1	0.008	-23.5	0.868	-174.8
500	0.932	-176.7	1.62	49.6	0.007	-24.4	0.876	-175.0
550	0.936	-177.0	1.42	46.7	0.007	-25.3	0.884	-175.1
600	0.937	-177.3	1.25	43.7	0.006	-26.5	0.892	-175.3
650	0.938	-177.7	1.10	40.9	0.006	-26.1	0.898	-175.5
700	0.939	-178.4	0.98	38.3	0.006	-25.0	0.907	-175.8
750	0.943	-178.8	0.88	35.6	0.005	-23.6	0.912	-176.0
800	0.946	-179.3	0.80	33.5	0.004	-19.9	0.915	-176.3
850	0.948	-179.9	0.73	31.5	0.004	-18.5	0.922	-176.7
900	0.956	179.7	0.67	29.8	0.004	-15.7	0.927	-177.0
950	0.960	179.6	0.61	28.1	0.003	-12.0	0.933	-177.3
1000	0.964	179.7	0.56	26.9	0.003	-7.7	0.937	-177.7
1050	0.963	179.3	0.51	25.5	0.003	-0.5	0.939	-178.0
1100	0.966	179.3	0.47	23.8	0.003	7.8	0.942	-178.4
1150	0.966	179.3	0.43	22.6	0.003	15.4	0.945	-178.6
1200	0.969	179.1	0.40	21.4	0.003	22.3	0.947	-179.0
1250	0.970	178.7	0.37	20.1	0.003	31.2	0.948	-179.4
1300	0.972	178.5	0.34	18.8	0.003	39.9	0.951	-179.5
1350	0.970	178.4	0.32	17.5	0.003	44.3	0.953	-179.7
1400	0.973	177.9	0.30	16.1	0.003	47.7	0.954	-179.9
1450	0.975	177.4	0.28	14.7	0.003	51.8	0.954	179.7
1500	0.974	176.6	0.26	13.6	0.004	60.0	0.955	179.4
1550	0.980	176.3	0.25	12.9	0.004	60.3	0.957	179.2
1600	0.983	175.7	0.24	12.0	0.004	62.3	0.958	178.8
1650	0.990	175.5	0.23	11.8	0.004	65.9	0.958	178.6
1700	0.996	175.6	0.21	11.2	0.005	66.9	0.959	178.3
1750	0.999	175.6	0.20	10.9	0.005	68.5	0.959	178.0
1800	0.999	175.6	0.20	10.4	0.005	69.5	0.961	177.7
1850	0.999	175.5	0.19	10.3	0.005	72.5	0.960	177.3
1900	0.999	175.4	0.18	10.4	0.006	72.6	0.962	177.0
1950	0.999	175.1	0.17	10.1	0.006	74.0	0.963	176.7
2000	0.999	174.6	0.16	10.0	0.006	75.7	0.965	176.5
2050	0.999	174.3	0.15	9.5	0.007	76.3	0.966	176.3
2100	0.999	173.6	0.14	9.0	0.007	74.3	0.968	176.0
2150	0.999	172.9	0.14	8.0	0.007	76.1	0.970	175.8
2200	0.999	172.2	0.13	7.1	0.008	77.1	0.972	175.7
2250	0.999	171.9	0.13	6.4	0.008	77.6	0.971	175.4
2300	0.999	171.6	0.12	5.8	0.008	77.0	0.972	175.2
2350	0.999	171.2	0.12	5.0	0.008	78.5	0.975	175.0
2400	0.999	170.9	0.11	4.5	0.009	78.2	0.973	174.9
2450	0.999	171.0	0.11	4.4	0.009	77.2	0.973	174.6
2500	0.999	170.8	0.11	4.4	0.009	77.7	0.974	174.4

Package Dimensions

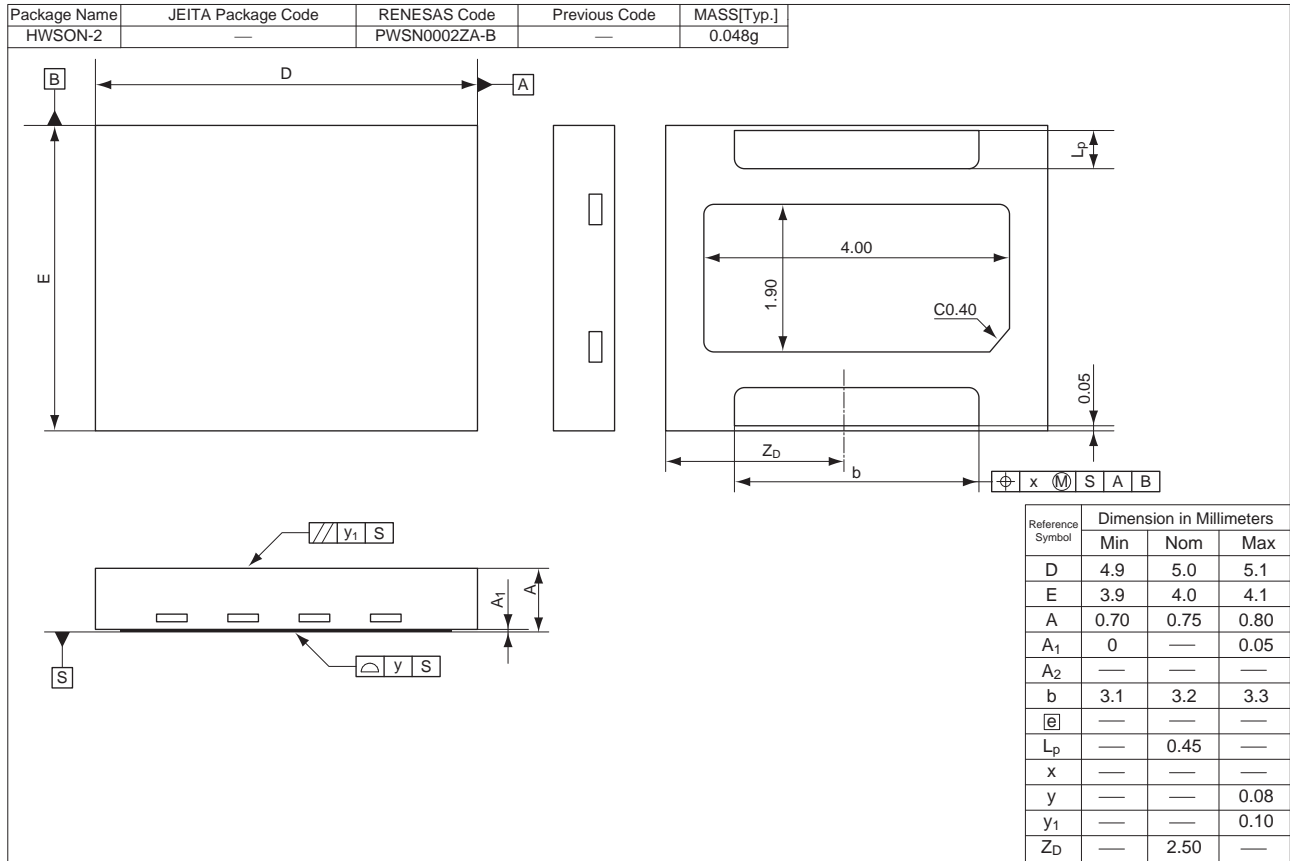

Ordering Information

Orderable Part Number	Quantity	Shipping Container
RQA0011DNSTB-E	2000 pcs.	φ178 mm Reel, 12 mm Emboss Taping

Notice

- All information included in this document is current as of the date this document is issued. Such information, however, is subject to change without any prior notice. Before purchasing or using any Renesas Electronics products listed herein, please confirm the latest product information with a Renesas Electronics sales office. Also, please pay regular and careful attention to additional and different information to be disclosed by Renesas Electronics such as that disclosed through our website.
- Renesas Electronics does not assume any liability for infringement of patents, copyrights, or other intellectual property rights of third parties by or arising from the use of Renesas Electronics products or technical information described in this document. No license, express, implied or otherwise, is granted hereby under any patents, copyrights or other intellectual property rights of Renesas Electronics or others.
- You should not alter, modify, copy, or otherwise misappropriate any Renesas Electronics product, whether in whole or in part.
- Descriptions of circuits, software and other related information in this document are provided only to illustrate the operation of semiconductor products and application examples. You are fully responsible for the incorporation of these circuits, software, and information in the design of your equipment. Renesas Electronics assumes no responsibility for any losses incurred by you or third parties arising from the use of these circuits, software, or information.
- When exporting the products or technology described in this document, you should comply with the applicable export control laws and regulations and follow the procedures required by such laws and regulations. You should not use Renesas Electronics products or the technology described in this document for any purpose relating to military applications or use by the military, including but not limited to the development of weapons of mass destruction. Renesas Electronics products and technology may not be used for or incorporated into any products or systems whose manufacture, use, or sale is prohibited under any applicable domestic or foreign laws or regulations.
- Renesas Electronics has used reasonable care in preparing the information included in this document, but Renesas Electronics does not warrant that such information is error free. Renesas Electronics assumes no liability whatsoever for any damages incurred by you resulting from errors in or omissions from the information included herein.
- Renesas Electronics products are classified according to the following three quality grades: "Standard", "High Quality", and "Specific". The recommended applications for each Renesas Electronics product depends on the product's quality grade, as indicated below. You must check the quality grade of each Renesas Electronics product before using it in a particular application. You may not use any Renesas Electronics product for any application categorized as "Specific" without the prior written consent of Renesas Electronics. Further, you may not use any Renesas Electronics product for any application for which it is not intended without the prior written consent of Renesas Electronics. Renesas Electronics shall not be in any way liable for any damages or losses incurred by you or third parties arising from the use of any Renesas Electronics product for an application categorized as "Specific" or for which the product is not intended where you have failed to obtain the prior written consent of Renesas Electronics. The quality grade of each Renesas Electronics product is "Standard" unless otherwise expressly specified in a Renesas Electronics data sheets or data books, etc.
"Standard": Computers; office equipment; communications equipment; test and measurement equipment; audio and visual equipment; home electronic appliances; machine tools; personal electronic equipment; and industrial robots.
"High Quality": Transportation equipment (automobiles, trains, ships, etc.); traffic control systems; anti-disaster systems; anti-crime systems; safety equipment; and medical equipment not specifically designed for life support.
"Specific": Aircraft; aerospace equipment; submersible repeaters; nuclear reactor control systems; medical equipment or systems for life support (e.g. artificial life support devices or systems), surgical implantations, or healthcare intervention (e.g. excision, etc.), and any other applications or purposes that pose a direct threat to human life.
- You should use the Renesas Electronics products described in this document within the range specified by Renesas Electronics, especially with respect to the maximum rating, operating supply voltage range, movement power voltage range, heat radiation characteristics, installation and other product characteristics. Renesas Electronics shall have no liability for malfunctions or damages arising out of the use of Renesas Electronics products beyond such specified ranges.
- Although Renesas Electronics endeavors to improve the quality and reliability of its products, semiconductor products have specific characteristics such as the occurrence of failure at a certain rate and malfunctions under certain use conditions. Further, Renesas Electronics products are not subject to radiation resistance design. Please be sure to implement safety measures to guard them against the possibility of physical injury, and injury or damage caused by fire in the event of the failure of a Renesas Electronics product, such as safety design for hardware and software including but not limited to redundancy, fire control and malfunction prevention, appropriate treatment for aging degradation or any other appropriate measures. Because the evaluation of microcomputer software alone is very difficult, please evaluate the safety of the final products or system manufactured by you.
- Please contact a Renesas Electronics sales office for details as to environmental matters such as the environmental compatibility of each Renesas Electronics product. Please use Renesas Electronics products in compliance with all applicable laws and regulations that regulate the inclusion or use of controlled substances, including without limitation, the EU RoHS Directive. Renesas Electronics assumes no liability for damages or losses occurring as a result of your noncompliance with applicable laws and regulations.
- This document may not be reproduced or duplicated, in any form, in whole or in part, without prior written consent of Renesas Electronics.
- Please contact a Renesas Electronics sales office if you have any questions regarding the information contained in this document or Renesas Electronics products, or if you have any other inquiries.
(Note 1) "Renesas Electronics" as used in this document means Renesas Electronics Corporation and also includes its majority-owned subsidiaries.
(Note 2) "Renesas Electronics product(s)" means any product developed or manufactured by or for Renesas Electronics.



SALES OFFICES

Renesas Electronics Corporation

<http://www.renesas.com>

Refer to "<http://www.renesas.com/>" for the latest and detailed information.

Renesas Electronics America Inc.
2880 Scott Boulevard Santa Clara, CA 95050-2554, U.S.A.
Tel: +1-408-588-6000, Fax: +1-408-588-6130

Renesas Electronics Canada Limited
1101 Nicholson Road, Newmarket, Ontario L3Y 9C3, Canada
Tel: +1-905-898-5441, Fax: +1-905-898-3220

Renesas Electronics Europe Limited
Dukes Meadow, Millboard Road, Bourne End, Buckinghamshire, SL8 5FH, U.K.
Tel: +44-1628-585-100, Fax: +44-1628-585-900

Renesas Electronics Europe GmbH
Arcadiastrasse 10, 40472 Düsseldorf, Germany
Tel: +49-211-65030, Fax: +49-211-6503-1327

Renesas Electronics (China) Co., Ltd.
7th Floor, Quantum Plaza, No.27 ZhiChunLu Haidian District, Beijing 100083, P.R.China
Tel: +86-10-8235-1155, Fax: +86-10-8235-7679

Renesas Electronics (Shanghai) Co., Ltd.
Unit 204, 205, AZIA Center, No.1233 Lujiazui Ring Rd., Pudong District, Shanghai 200120, China
Tel: +86-21-5877-1818, Fax: +86-21-6887-7858 / -7898

Renesas Electronics Hong Kong Limited
Unit 1601-1613, 16/F., Tower 2, Grand Century Place, 193 Prince Edward Road West, Mongkok, Kowloon, Hong Kong
Tel: +852-2886-9318, Fax: +852 2886-9022/9044

Renesas Electronics Taiwan Co., Ltd.
13F, No. 363, Fu Shing North Road, Taipei, Taiwan
Tel: +886-2-8175-9600, Fax: +886 2-8175-9670

Renesas Electronics Singapore Pte. Ltd.
1 HarbourFront Avenue, #06-10, Keppel Bay Tower, Singapore 098632
Tel: +65-6213-0200, Fax: +65-6278-8001

Renesas Electronics Malaysia Sdn.Bhd.
Unit 906, Block B, Menara Amcorp, Amcorp Trade Centre, No. 18, Jln Persiaran Barat, 46050 Petaling Jaya, Selangor Darul Ehsan, Malaysia
Tel: +60-3-7955-9390, Fax: +60-3-7955-9510

Renesas Electronics Korea Co., Ltd.
11F., Samik Lavied' or Bldg., 720-2 Yeoksam-Dong, Kangnam-Ku, Seoul 135-080, Korea
Tel: +82-2-558-3737, Fax: +82-2-558-5141