

TRANSZORB® Transient Voltage Suppressors

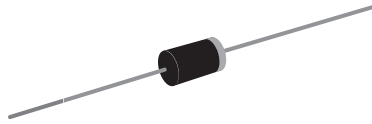

DO-204AC (DO-15)

PRIMARY CHARACTERISTICS	
V_{BR} uni-directional	6.8 V to 540 V
V_{BR} bi-directional	6.8 V to 440 V
P_{PPM}	600 W
P_D	5.0 W
I_{FSM} (uni-directional only)	100 A
T_J max.	175 °C

DEVICES FOR BI-DIRECTION APPLICATIONS

For bi-directional types, use C or CA suffix (e.g. P6KE440CA).

Electrical characteristics apply in both directions.

FEATURES

- Glass passivated chip junction
- Available in uni-directional and bi-directional
- 600 W peak pulse power capability with a 10/1000 μ s waveform, repetitive rate (duty cycle): 0.01 %
- Excellent clamping capability
- Very fast response time
- Low incremental surge resistance
- Solder dip 260 °C, 40 s
- Component in accordance to RoHS 2002/95/EC and WEEE 2002/96/EC



RoHS
COMPLIANT

TYPICAL APPLICATIONS

Use in sensitive electronics protection against voltage transients induced by inductive load switching and lighting on ICs, MOSFET, signal lines of sensor units for consumer, computer, industrial, automotive and telecommunication.

MECHANICAL DATA

Case: DO-204AC, molded epoxy over passivated chip
Molding compound meets UL 94 V-0 flammability rating

Base P/N-E3 - RoHS compliant, commercial grade

Base P/NHE3 - RoHS compliant, high reliability/automotive grade (AEC Q101 qualified)

Terminals: Matte tin plated leads, solderable per J-STD-002 and JESD22-B102

E3 suffix meets JESD 201 class 1A whisker test, HE3 suffix meets JESD 201 class 2 whisker test

Note:

- P6KE250 ~ P6KE540A and P6KE250C ~ P6KE440CA for commercial grade only

Polarity: For uni-directional types the color band denotes cathode end, no marking on bi-directional types

MAXIMUM RATINGS ($T_A = 25$ °C unless otherwise noted)			
PARAMETER	SYMBOL	VALUE	UNIT
Peak power dissipation with a 10/1000 μ s waveform ⁽¹⁾ (Fig. 1)	P_{PPM}	600	W
Peak pulse current with a 10/1000 μ s waveform ⁽¹⁾	I_{PPM}	See next table	A
Power dissipation on infinite heatsink at $T_L = 75$ °C (Fig. 5)	P_D	5.0	W
Peak forward surge current, 8.3 ms single half sine-wave ⁽²⁾	I_{FSM}	100	A
Maximum instantaneous forward voltage at 50 A for uni-directional only ⁽³⁾	V_F	3.5/5.0	V
Operating junction and storage temperature range	T_J, T_{STG}	- 55 to + 175	°C

Notes:

(1) Non-repetitive current pulse, per Fig. 3 and derated above $T_A = 25$ °C per Fig. 2

(2) Measured on 8.3 ms single half sine-wave or equivalent square wave, duty cycle = 4 per minute maximum

(3) $V_F = 3.5$ V for P6KE220(A) and below; $V_F = 5.0$ V for P6KE250(A) and above

P6KE6.8 thru P6KE540A

Vishay General Semiconductor



ELECTRICAL CHARACTERISTICS (T _A = 25 °C unless otherwise noted)								
DEVICE TYPE	BREAKDOWN VOLTAGE V _{BR} AT I _T (1) (V)		TEST CURRENT I _T (mA)	STAND-OFF VOLTAGE V _{WM} (V)	MAXIMUM REVERSE LEAKAGE AT V _{WM} (3) I _D (μA)	PEAK PULSE CURRENT I _{PPM} (2) (A)	MAXIMUM CLAMPING VOLTAGE AT I _{PPM} V _C (V)	MAXIMUM TEMPERATURE COEFFICIENT OF V _{BR} (%/°C)
	MIN.	MAX.						
(+)P6KE6.8	6.12	7.48	10	5.50	1000	55.6	10.8	0.057
(+)P6KE6.8A	6.45	7.14	10	5.80	1000	57.1	10.5	0.057
(+)P6KE7.5	6.75	8.25	10	6.05	500	51.3	11.7	0.061
(+)P6KE7.5A	7.13	7.88	10	6.40	500	53.1	11.3	0.061
(+)P6KE8.2	7.38	9.02	10	6.63	200	48.0	12.5	0.065
(+)P6KE8.2A	7.79	8.61	10	7.02	200	49.6	12.1	0.065
(+)P6KE9.1	8.19	10.0	1.0	7.37	50	43.5	13.8	0.068
(+)P6KE9.1A	8.65	9.55	1.0	7.78	50	44.8	13.4	0.068
(+)P6KE10	9.00	11.0	1.0	8.10	10	40.0	15.0	0.073
(+)P6KE10A	9.50	10.5	1.0	8.55	10	41.4	14.5	0.073
(+)P6KE11	9.90	12.1	1.0	8.92	5.0	37.0	16.2	0.075
(+)P6KE11A	10.5	11.6	1.0	9.40	5.0	38.5	15.6	0.075
(+)P6KE12	10.8	13.2	1.0	9.72	5.0	34.7	17.3	0.078
(+)P6KE12A	11.4	12.6	1.0	10.2	5.0	35.9	16.7	0.078
(+)P6KE13	11.7	14.3	1.0	10.5	5.0	31.6	19.0	0.081
(+)P6KE13A	12.4	13.7	1.0	11.1	5.0	33.0	18.2	0.081
(+)P6KE15	13.5	16.5	1.0	12.1	1.0	27.3	22.0	0.084
(+)P6KE15A	14.3	15.8	1.0	12.8	1.0	28.3	21.2	0.084
(+)P6KE16	14.4	17.6	1.0	12.9	1.0	25.5	23.5	0.086
(+)P6KE16A	15.2	16.8	1.0	13.6	1.0	26.7	22.5	0.086
(+)P6KE18	16.2	19.8	1.0	14.5	1.0	22.6	26.5	0.088
(+)P6KE18A	17.1	18.9	1.0	15.3	1.0	23.8	25.2	0.088
(+)P6KE20	18.0	22.0	1.0	16.2	1.0	20.6	29.1	0.090
(+)P6KE20A	19.0	21.0	1.0	17.1	1.0	21.7	27.7	0.090
(+)P6KE22	19.8	24.2	1.0	17.8	1.0	18.8	31.9	0.092
(+)P6KE22A	20.9	23.1	1.0	18.8	1.0	19.6	30.6	0.092
(+)P6KE24	21.6	26.4	1.0	19.4	1.0	17.3	34.7	0.094
(+)P6KE24A	22.8	25.2	1.0	20.5	1.0	18.1	33.2	0.094
(+)P6KE27	24.3	29.7	1.0	21.8	1.0	15.3	39.1	0.096
(+)P6KE27A	25.7	28.4	1.0	23.1	1.0	16.0	37.5	0.096
(+)P6KE30	27.0	33.0	1.0	24.3	1.0	13.8	43.5	0.097
(+)P6KE30A	28.5	31.5	1.0	25.6	1.0	14.5	41.4	0.097
(+)P6KE33	29.7	36.3	1.0	26.8	1.0	12.6	47.7	0.098
(+)P6KE33A	31.4	34.7	1.0	28.2	1.0	13.1	45.7	0.098
(+)P6KE36	32.4	39.6	1.0	29.1	1.0	11.5	52.0	0.099
(+)P6KE36A	34.2	37.8	1.0	30.8	1.0	12.0	49.9	0.099
(+)P6KE39	35.1	42.9	1.0	31.6	1.0	10.6	56.4	0.100
(+)P6KE39A	37.1	41.0	1.0	33.3	1.0	11.1	53.9	0.100
(+)P6KE43	38.7	47.3	1.0	34.8	1.0	9.7	61.9	0.101
(+)P6KE43A	40.9	45.2	1.0	36.8	1.0	10.1	59.3	0.101
(+)P6KE47	42.3	51.7	1.0	38.1	1.0	8.8	67.8	0.101
(+)P6KE47A	44.7	49.4	1.0	40.2	1.0	9.3	64.8	0.101



ELECTRICAL CHARACTERISTICS ($T_A = 25\text{ }^\circ\text{C}$ unless otherwise noted)								
DEVICE TYPE	BREAKDOWN VOLTAGE V_{BR} AT I_T ⁽¹⁾ (V)		TEST CURRENT I_T (mA)	STAND-OFF VOLTAGE V_{WM} (V)	MAXIMUM REVERSE LEAKAGE AT V_{WM} ⁽³⁾ I_D (μA)	PEAK PULSE CURRENT I_{PPM} ⁽²⁾ (A)	MAXIMUM CLAMPING VOLTAGE AT I_{PPM} V_C (V)	MAXIMUM TEMPERATURE COEFFICIENT OF V_{BR} (%/ $^\circ\text{C}$)
	MIN.	MAX.						
(+)P6KE51	45.9	56.1	1.0	41.3	1.0	8.2	73.5	0.102
(+)P6KE51A	48.5	53.6	1.0	43.6	1.0	8.6	70.1	0.102
(+)P6KE56	50.4	61.6	1.0	45.4	1.0	7.5	80.5	0.103
(+)P6KE56A	53.2	58.8	1.0	47.8	1.0	7.8	77.0	0.103
(+)P6KE62	55.8	68.2	1.0	50.2	1.0	6.7	89.0	0.104
(+)P6KE62A	58.9	65.1	1.0	53.0	1.0	7.1	85.0	0.104
(+)P6KE68	61.2	74.8	1.0	55.1	1.0	6.1	98.0	0.104
(+)P6KE68A	64.6	71.4	1.0	58.1	1.0	6.5	92.0	0.104
(+)P6KE75	67.5	82.5	1.0	60.7	1.0	5.6	108	0.105
(+)P6KE75A	71.3	78.8	1.0	64.1	1.0	5.8	103	0.105
(+)P6KE82	73.8	90.2	1.0	66.4	1.0	5.1	118	0.105
(+)P6KE82A	77.9	86.1	1.0	70.1	1.0	5.3	113	0.105
(+)P6KE91	81.9	100	1.0	73.7	1.0	4.6	131	0.106
(+)P6KE91A	86.5	95.5	1.0	77.8	1.0	4.8	125	0.106
(+)P6KE100	90.0	110	1.0	81.0	1.0	4.2	144	0.106
(+)P6KE100A	95.0	105	1.0	85.5	1.0	4.4	137	0.106
(+)P6KE110	99.0	121	1.0	89.2	1.0	3.8	158	0.107
(+)P6KE110A	105	116	1.0	94.0	1.0	3.9	152	0.107
(+)P6KE120	108	132	1.0	97.2	1.0	3.5	173	0.107
(+)P6KE120A	114	126	1.0	102	1.0	3.6	165	0.107
(+)P6KE130	117	143	1.0	105	1.0	3.2	187	0.107
(+)P6KE130A	124	137	1.0	111	1.0	3.4	179	0.107
(+)P6KE150	135	165	1.0	121	1.0	2.8	215	0.108
(+)P6KE150A	143	158	1.0	128	1.0	2.9	207	0.108
(+)P6KE160	144	176	1.0	130	1.0	2.6	230	0.108
(+)P6KE160A	152	168	1.0	136	1.0	2.7	219	0.108
(+)P6KE170	153	187	1.0	138	1.0	2.5	244	0.108
(+)P6KE170A	162	179	1.0	145	1.0	2.6	234	0.108
(+)P6KE180	162	198	1.0	146	1.0	2.3	258	0.108
(+)P6KE180A	171	189	1.0	154	1.0	2.4	246	0.108
(+)P6KE200	180	220	1.0	162	1.0	2.1	287	0.108
(+)P6KE200A	190	210	1.0	171	1.0	2.2	274	0.108
(+)P6KE220	198	242	1.0	175	1.0	1.7	344	0.108
(+)P6KE220A	209	231	1.0	185	1.0	1.8	328	0.108
(+)P6KE250	225	275	1.0	202	1.0	1.7	360	0.110
(+)P6KE250A	237	263	1.0	214	1.0	1.7	344	0.110
(+)P6KE300	270	330	1.0	243	1.0	1.4	430	0.110
(+)P6KE300A	285	315	1.0	256	1.0	1.4	414	0.110
(+)P6KE350	315	385	1.0	284	1.0	1.2	504	0.110
(+)P6KE350A	333	368	1.0	300	1.0	1.2	482	0.110
(+)P6KE400	360	440	1.0	324	1.0	1.0	574	0.110
(+)P6KE400A	380	420	1.0	342	1.0	1.1	548	0.110

P6KE6.8 thru P6KE540A

Vishay General Semiconductor



ELECTRICAL CHARACTERISTICS ($T_A = 25\text{ }^\circ\text{C}$ unless otherwise noted)								
DEVICE TYPE	BREAKDOWN VOLTAGE V_{BR} AT I_T ⁽¹⁾ (V)		TEST CURRENT I_T (mA)	STAND-OFF VOLTAGE V_{WM} (V)	MAXIMUM REVERSE LEAKAGE AT V_{WM} ⁽³⁾ I_D (μA)	PEAK PULSE CURRENT I_{PPM} ⁽²⁾ (A)	MAXIMUM CLAMPING VOLTAGE AT I_{PPM} V_C (V)	MAXIMUM TEMPERATURE COEFFICIENT OF V_{BR} (%/ $^\circ\text{C}$)
	MIN.	MAX.						
(+)P6KE440	396	484	1.0	356	1.0	0.95	631	0.110
(+)P6KE440A	418	462	1.0	376	1.0	1.00	602	0.110
P6KE480	432	528	1.0	389	1.0	0.88	686	0.110
P6KE480A	456	504	1.0	408	1.0	0.91	658	0.110
P6KE510	459	561	1.0	413	1.0	0.82	729	0.110
P6KE510A	485	535	1.0	434	1.0	0.86	698	0.110
P6KE540	486	594	1.0	437	1.0	0.78	772	0.110
P6KE540A	513	567	1.0	459	1.0	0.81	740	0.110

Notes:

- (1) Pulse test: $t_p \leq 50\text{ ms}$
- (2) Surge current waveform per Fig. 3 and derate per Fig. 2ogm
- (3) For bi-directional types with V_{WM} of 10 V and less, the I_D limit is doubled
- (4) All terms and symbols are consistent with ANSI/IEEE C62.35
- (+) Underwriters laboratory recognition for the classification of protectors (QVQG2) under the UL standard for safety 497B and file number E136766 for both uni-directional and bi-directional devices

THERMAL CHARACTERISTICS ($T_A = 25\text{ }^\circ\text{C}$ unless otherwise noted)			
PARAMETER	SYMBOL	VALUE	UNIT
Typical thermal resistance, junction to lead	$R_{\theta JL}$	20	$^\circ\text{C/W}$
Typical thermal resistance, junction to ambient	$R_{\theta JA}$	75	$^\circ\text{C/W}$

ORDERING INFORMATION (Example)				
PREFERRED P/N	UNIT WEIGHT (g)	PREFERRED PACKAGE CODE	BASE QUANTITY	DELIVERY MODE
P6KE6.8A-E3/54	0.432	54	4000	13" diameter paper tape and reel
P6KE6.8AHE3/54 ⁽¹⁾	0.432	54	4000	13" diameter paper tape and reel

Note:

- (1) Automotive grade AEC-Q101 qualified

RATINGS AND CHARACTERISTICS CURVES

($T_A = 25\text{ }^\circ\text{C}$ unless otherwise noted)

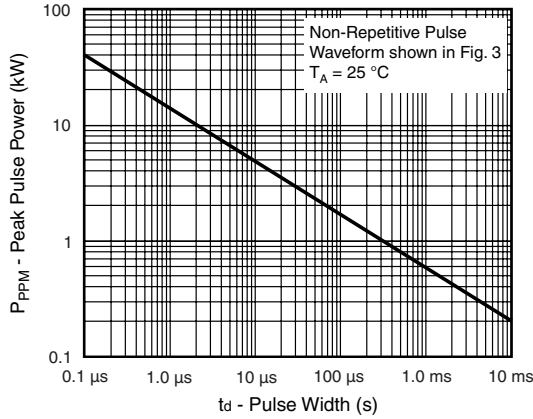

Figure 1. Peak Pulse Power Rating Curve

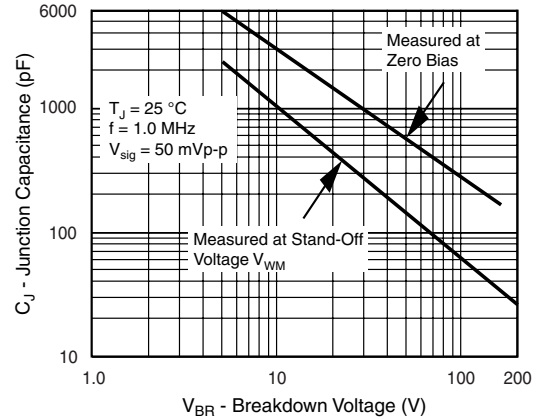

Figure 4. Typical Junction Capacitance Uni-Directional

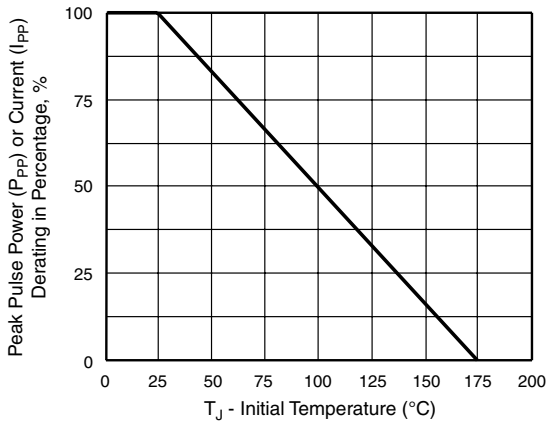

Figure 2. Pulse Power or Current vs. Initial Junction Temperature

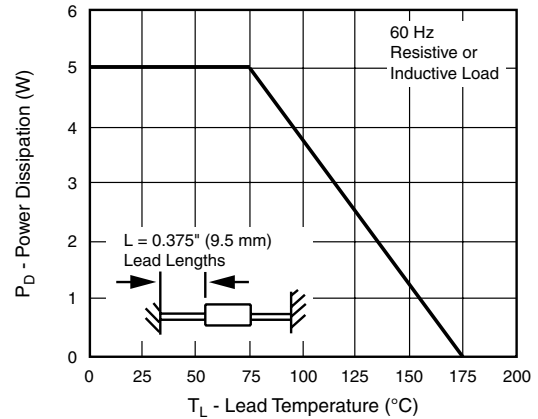

Figure 5. Power Derating Curve

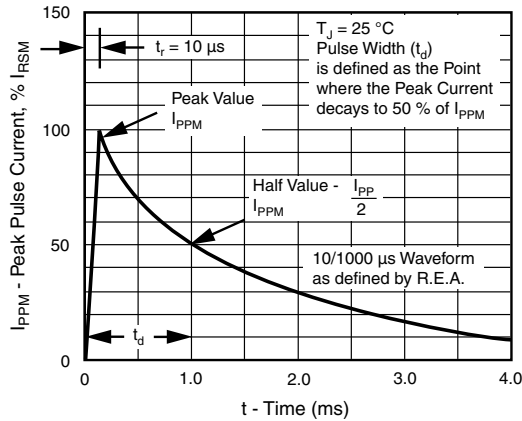

Figure 3. Pulse Waveform

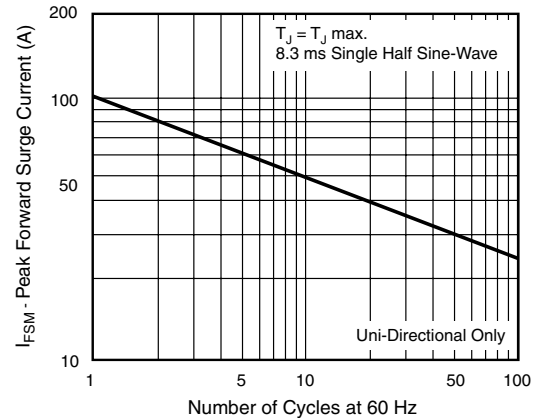

Figure 6. Maximum Non-Repetitive Forward Surge Current

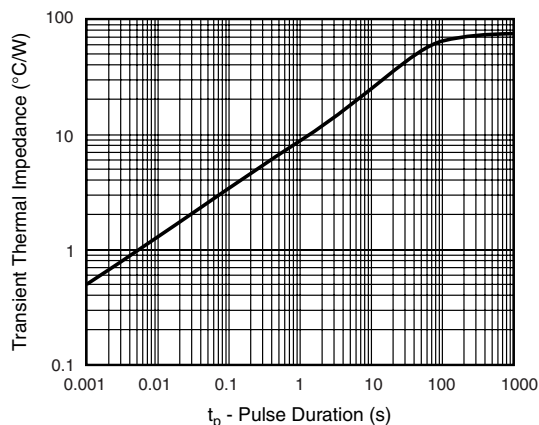
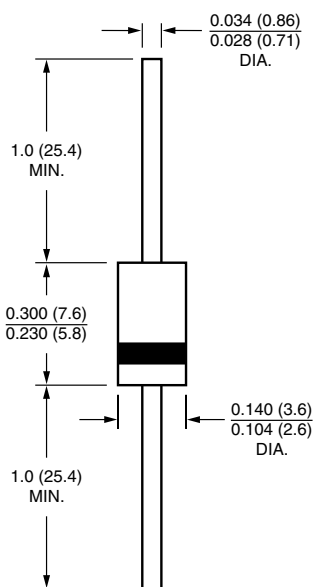

Figure 7. Typical Transient Thermal Impedance

PACKAGE OUTLINE DIMENSIONS in inches (millimeters)

DO-204AC (DO-15)



APPLICATION NOTE

This P6KE TVS series is a low cost commercial product for use in applications where large voltage transients can permanently damage voltage-sensitive components.

The P6KE series device types are designed in a small package size where power and space is a consideration. They are characterized by their high surge capability, extremely fast response time, and low impedance, (R_{on}). Because of the unpredictable nature of transients, and the variation of the impedance with respect to these transients, impedance, per se, is not specified as a parametric value. However, a minimum voltage at low current conditions (BV) and a maximum clamping voltage (V_C) at a maximum peak pulse current is specified.

In some instances, the thermal effect (see V_C Clamping Voltage) may be responsible for 50 % to 70 % of the observed voltage differential when subjected to high current pulses for several duty cycles, thus making a maximum impedance specification insignificant.

In case of a severe current overload or abnormal transient beyond the maximum ratings, the Transient Voltage Suppressor will initially fail 'short' thus tripping the system's circuit breaker or fuse while protecting the entire circuit. Curves depicting clamping voltage vs. various current pulses are available from the factory. Extended power curves vs. pulse time are also available.



Disclaimer

ALL PRODUCT, PRODUCT SPECIFICATIONS AND DATA ARE SUBJECT TO CHANGE WITHOUT NOTICE TO IMPROVE RELIABILITY, FUNCTION OR DESIGN OR OTHERWISE.

Vishay Intertechnology, Inc., its affiliates, agents, and employees, and all persons acting on its or their behalf (collectively, "Vishay"), disclaim any and all liability for any errors, inaccuracies or incompleteness contained in any datasheet or in any other disclosure relating to any product.

Vishay makes no warranty, representation or guarantee regarding the suitability of the products for any particular purpose or the continuing production of any product. To the maximum extent permitted by applicable law, Vishay disclaims (i) any and all liability arising out of the application or use of any product, (ii) any and all liability, including without limitation special, consequential or incidental damages, and (iii) any and all implied warranties, including warranties of fitness for particular purpose, non-infringement and merchantability.

Statements regarding the suitability of products for certain types of applications are based on Vishay's knowledge of typical requirements that are often placed on Vishay products in generic applications. Such statements are not binding statements about the suitability of products for a particular application. It is the customer's responsibility to validate that a particular product with the properties described in the product specification is suitable for use in a particular application. Parameters provided in datasheets and/or specifications may vary in different applications and performance may vary over time. All operating parameters, including typical parameters, must be validated for each customer application by the customer's technical experts. Product specifications do not expand or otherwise modify Vishay's terms and conditions of purchase, including but not limited to the warranty expressed therein.

Except as expressly indicated in writing, Vishay products are not designed for use in medical, life-saving, or life-sustaining applications or for any other application in which the failure of the Vishay product could result in personal injury or death. Customers using or selling Vishay products not expressly indicated for use in such applications do so at their own risk and agree to fully indemnify and hold Vishay and its distributors harmless from and against any and all claims, liabilities, expenses and damages arising or resulting in connection with such use or sale, including attorneys fees, even if such claim alleges that Vishay or its distributor was negligent regarding the design or manufacture of the part. Please contact authorized Vishay personnel to obtain written terms and conditions regarding products designed for such applications.

No license, express or implied, by estoppel or otherwise, to any intellectual property rights is granted by this document or by any conduct of Vishay. Product names and markings noted herein may be trademarks of their respective owners.

Material Category Policy

Vishay Intertechnology, Inc. hereby certifies that all its products that are identified as RoHS-Compliant fulfill the definitions and restrictions defined under Directive 2011/65/EU of The European Parliament and of the Council of June 8, 2011 on the restriction of the use of certain hazardous substances in electrical and electronic equipment (EEE) - recast, unless otherwise specified as non-compliant.

Please note that some Vishay documentation may still make reference to RoHS Directive 2002/95/EC. We confirm that all the products identified as being compliant to Directive 2002/95/EC conform to Directive 2011/65/EU.



Packaging Information

PACKAGING ORDERING CODE		
ANTI-STATIC PACKAGE CODE	PREFERRED PACKAGE CODE	PACKAGING DESCRIPTION
51		Bulk
52, 52T	P	DO-214AA (SMB)/DO-215AA (SMBG), 12 mm tape, 7" diameter plastic reel
2D	P	DO-218AB (SM5-8A), 24 mm tape, 13" diameter plastic reel, anode towards sprocket hole
2E		DO-218AB (SM5-8A), 24 mm tape, 13" diameter plastic reel, cathode towards sprocket hole
2M		Tube packaging for 5KP/6KA type lead formed components
2N		DO-218AB, 24 mm tape, 13" diameter plastic reel with dry packaging, anode towards sprocket hole
53		26 mm horizontal taping and ammo box packaging
54	P	52.4 mm horizontal tape, 13" diameter paper reel
5A, 5AT	P	DO-214AC (SMA), 12 mm tape, 13" diameter plastic reel
5B, 5BT	P	DO-214AA (SMB)/DO-215AA (SMBG), 12 mm tape, 13" diameter plastic reel
5CA	P	DO-214BA (GF1), 12 mm tape, 13" diameter plastic reel
57, 57T	P	DO-214AB (SMC)/DO-215AB (SMCG), 16 mm tape, 7" diameter plastic reel
6A	P	DO-221AC (SlimSMA), 12 mm tape, 7" diameter plastic reel
6B	P	DO-221AC (SlimSMA), 12 mm tape, 13" diameter plastic reel
9A, 9AT	P	DO-214AB (SMC)/DO-215AB (SMCG), 16 mm tape, 13" diameter plastic reel
61, 61T	P	DO-214AC (SMA), 12 mm tape, 7" diameter plastic reel
67A	P	DO-214BA (GF1), 12 mm tape, 7" diameter plastic reel
72	P	Bulk pack for bridge and special axial-leaded formed devices
73		52.4 mm horizontal tape and ammo box packaging
77	P	DFS bridge, 16 mm tape, 13" diameter paper reel
80	P	TO-269AA (MB-S) bridge, 12 mm tape, 13" diameter paper reel
81	P	TO-263AB 24 mm tape, 13" diameter reinforced hub plastic reel
8A	P	SMPD, 24 mm tape, 13" diameter plastic reel
8W	P	TO-263AB (wire bond) 24 mm tape, 13" diameter reinforced hub plastic reel
83	P	DO-213AA (GL34) 8 mm tape, 13" diameter plastic reel
84A	P	DO-220AA (SMP) 12 mm tape, 7" diameter plastic reel
85A	P	DO-220AA (SMP) 12 mm tape, 13" diameter plastic reel
86A	P	TO-277A (SMPC), 12 mm tape, 7" diameter plastic reel
87A	P	TO-277A (SMPC), 12 mm tape, 13" diameter plastic reel
38		Lead forming bulk packaging in anti-static bags
89A	P	MicroSMP, 8 mm tape, 7" diameter plastic reel
90		Euroform, reel, cathode first off reel, lead coated
91		Euroform, ammo pack, cathode first out of ammo pack, lead coated
92		Euroform, reel, cathode last off reel, lead coated
93		Euroform, ammo pack, cathode last out of ammo pack, lead coated
45	P	Anti-static tube packaging for Bridge and Power Pack
4W	P	Anti-static tube packaging for wire bond TO-220, ITO-220, TO-262 and TO-263
96	P	DO-213AB (GL41), 12 mm tape, 7" diameter plastic reel
97	P	DO-213AB (GL41), 12 mm tape, 13" diameter plastic reel
98	P	DO-213AA (GL34), 8 mm tape, 7" diameter plastic reel
100		MPG06 pseudo radial tape, cathode first out of ammo pack
H	P	Tape in 7" diameter plastic reel
I	P	Tape in 13" diameter plastic reel
TR	P	DO-214AC (SMA), 12 mm tape, 7" diameter plastic reel ⁽¹⁾
TR3	P	DO-214AC (SMA), 12 mm tape, 13" diameter plastic reel ⁽¹⁾

Notes

- ⁽¹⁾ Formerly sold by Vishay Telefunken® (Telefunken® is a registered trademark of Electro Holding GmbH).
- "P" and bold letter denotes preferred package code.
- A "T" suffix added to the packaging codes for SMA, SMB and SMC products indicates that the patented folded-frame construction is used. This does not apply to TR and TR3 codes or TRANSZORB® TVS in SMA and SMB.



BULK PACKAGING					
CASE TYPES	PREFERRED PACKAGE CODE	PACKAGING	BOX SIZE		QUANTITY
			INCHES	cm	EA.
DF-M, DF-S, DFL-S	45	Anti-static plastic tubes	17.4 length	44.1 length	50
GSIB-3S	45	Anti-static plastic tubes	25.1 length	63.9 length	20
GSIB-5S, PB	45	Anti-static plastic tubes	24.2 length	61.5 length	20
GBU, BU	45	Anti-static plastic tubes	18.5 length	47 length	20
GBL	45	Anti-static plastic tubes	17.5 length	44.5 length	20
KBPM	45	Anti-static plastic tubes	18.5 length	47 length	30
TO-220AB/AC, ITO-220AC/AB, TO-262AA	45, 4W	Anti-static plastic tubes	21.0 length	53.7 length	50
TO-247AD	45	Anti-static plastic tubes	20.0 length	50.8 length	30
TO-269AA (MB-S)	45	Anti-static plastic tubes	20.3 x 0.41	51.5 x 1.04	100
KBPM	51	Anti-static PVC tray	12.5 x 6.5 x 1.25	31.7 x 16.5 x 3.17	600
GBL	51	Anti-static PVC tray	12.5 x 6.1 x 1.0	30.9 x 15.5 x 2.5	400
GBPC12-35W	51	Paper box	12.5 x 12.5 x 1.7	31.7 x 31.7 x 4.3	100
GBPC1, GBPC6	51	Paper box	7.5 x 7.5 x 1.43	19.0 x 19.0 x 3.6	100
KBL	51	Anti-static PVC tray	12.2 x 6.1 x 1.5	30.9 x 15.5 x 3.8	300
GBPC12-35	51	Paper box	12.5 x 12.5 x 1.7	31.7 x 31.7 x 4.3	100
KBU4, 6, 8	51	Anti-static PVC tray	12.2 x 6.1 x 1.5	30.9 x 15.5 x 3.8	250
WOG, 2WOG	51	Plastic bags	-	-	100
GBU, /BU	51	Paper tray	13.1 x 6.6 x 1.2	33.2 x 17.2 x 3.0	250
KBPM	72	Paper box	7.4 x 7.4 x 1.5	18.8 x 18.8 x 3.8	200

AXIAL-LEADED TAPE AND REEL PACKAGING

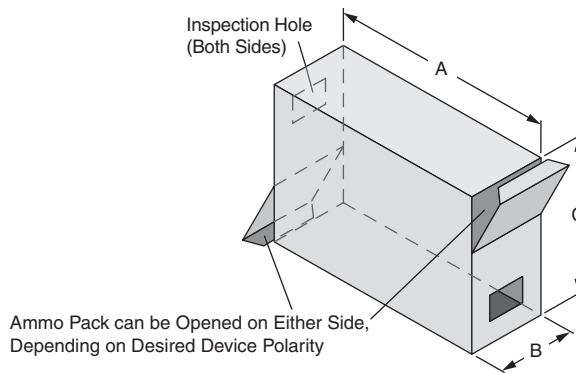

All axial-leaded devices are packed in accordance with EIA standard RS-296-E. The diagrams given below refer to these specifications.

TABLE 1 - AMMO PACK PACKAGING						
PACKAGING	AVAILABLE PRODUCT OUTLINES	PREFERRED PACKAGE CODE	DIMENSION A	DIMENSION B	DIMENSION C	QUANTITY BOX
26 mm horizontal tape, ammo pack	DO-204AL (DO-41), MPG06	53	9.7" (247 mm)	1.7" (44 mm)	3.7" (95 mm)	3.0K
	DO-204AC	53				1.5K
	P300	53				0.75K
52 mm horizontal tape, ammo pack	DO-204AL, MPG06	73	10.0" (255 mm)	3.15" (80 mm)	4.53" (115 mm)	3.0K
	DO-204AC	73				2.0K
	DO201AD, GP20	73				1.0K
	P600	73				0.3K
Radial (avisert, panasert, euroform) vertical tape	GP10-E, RGP10-E, GP10-E, RGP10-E	91, 93	13.4" (340 mm)	1.8" (47 mm)	7.9" (200 mm)	2.0K 2.5K 2.0K
Pseudo/radial tape, ammo pack	MPG06	100	13.4" (340 mm)	1.8" (47 mm)	7.9" (200 mm)	2.0K

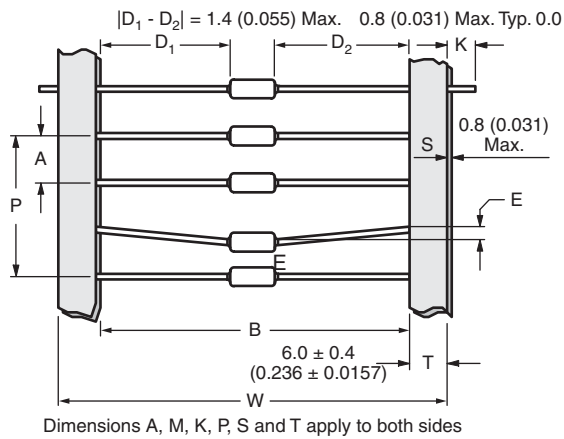

Description	Symbol	
Component Pitch	A	2, 3
Inside Tape Spacing	B	2, 3
Lead to Lead Eccentricity	$ D_1 - D_2 $	-
Lead Extension	K	-
Lead Bending	E	2
Cumulative Pitch	P	3
Exposed Adhesive	S	-
Tape Width	T	-

All polarized components shall be oriented in the same direction

Fig. 1

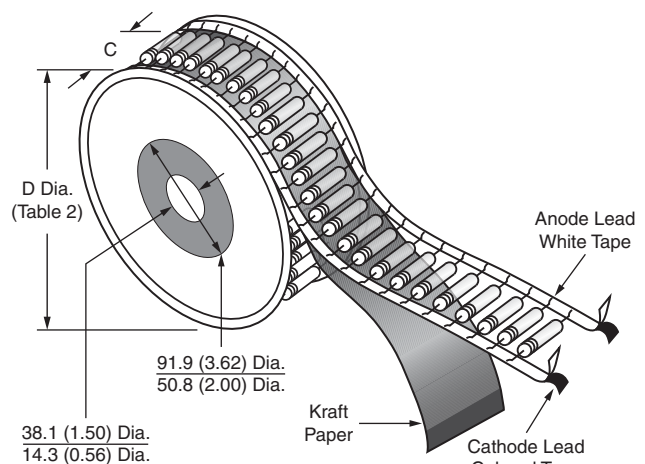

The "C" dimension of Fig. 2 is between flanges of the component reel and shall be 1.5 mm (0.059") to 8.00 mm (0.315") greater than the overall taped component width "W" (Fig. 1). Where "W" dimension is 68.2 mm (2.68") max.

Fig. 2



AXIAL-LEADED TAPE AND REEL PACKAGING

TABLE 2 - REEL AND AMMO PACK TAPING SPECIFICATIONS										
COMPONENT CASE TYPE	PREFERRED PACKAGE CODE	UNITS PER REEL	COMPONENT PITCH "A" Fig. 1		INSIDE TAPE SPACING "B" Fig. 1		REEL DIMENSION "D" Fig. 2		LEAD BENDING "E" Fig. 1	
			EA.	INCHES	mm	INCHES	mm	INCHES	mm	INCHES
1.5KA (PAR)	54	1400	0.395	10.0	2.06	52.4	13.0	330	0.047	1.2
DO-204AC	54	4000	0.200	5.0	2.06	52.4	13.0	330	0.047	1.2
DO-201AD	54	1400	0.395	10.0	2.06	52.4	13.0	330	0.047	1.2
DO-204AL	54	5500	0.200	5.0	2.06	52.4	13.0	330	0.047	1.2
DFS Surface Mount	77	1500	Fig. 13		-	-	13.0	330	Fig. 13	-
DO-214BA (GF1)	67A/5CA	1500/6500			-	-	7.0/13.0	178/330	Fig. 13	-
DO-213AA (GL34)	98/83	2500/9000			-	-	7.0/13.0	178/330	Fig. 13	-
DO-213AB (GL41)	96/97	1500/5000			-	-	7.0/13.0	178/330	Fig. 13	-
GP10E Radial	Fig. 7 and Fig. 8	2500	0.500	12.7	-	-	13.0	330	0.079	2.0
GP10E	54	5500	0.200	5.0	2.06	52.4	13.0	330	0.047	1.2
GP20/1.5KE	54	1400	0.395	10.0	2.06	52.4	13.0	330	0.047	1.2
MPG06	100	5500	0.200	5.0	2.06	52.4	13.0	330	0.047	1.2
P600	54	800	0.395	10.0	2.06	52.4	13.0	330	0.047	1.2
DO-220AA (SMP)	84A/85A	3000/10 000	Fig. 13		-	-	7.0/13.0	178/330	Fig. 13	-
SMPD	8A	2000			-	-	13.0	330	Fig. 13	-
MicroSMP	89A	4500			-	-	7.0	178	Fig. 13	-
TO-277A (SMPC)	86A/87A	1500/6500			-	-	7.0/13.0	178/330	Fig. 13	-
DO-214AC (SMA)	61, 61T, TR/5A, 5AT, TR3	1800/7500			-	-	7.0/13.0	178/330	Fig. 13	-
DO-214AA (SMB)/ DO-215AA (SMBG)	52, 52T/5B, 5BT	750/3200			-	-	7.0/13.0	178/330	Fig. 13	-
DO-214AB (SMC)/ DO-215AB (SMCG)	57T/9AT	850/3500			-	-	7.0/13.0	178/330	Fig. 13	-
DO-218AB	2D	750			-	-	13.0	330	Fig. 13	-
TO-263AB	81, 8W	800			-	-	13.0	330	Fig. 13	-
TO-269AA (MB-S)	80	3000			-	-	13.0	330	Fig. 13	-
DO-221AC (SlimSMA)	6A/6B	3500/14 000			-	-	7.0/13.0	178/330	Fig. 13	-

Note

- Package codes, 61/5A, 52/5B are matrix-frame constructions for TRANSZORB® TVS in SMA and SMB only.

TABLE 3 - COMPONENT AND INSIDE HORIZONTAL TAPE SPACING			
COMPONENT BODY DIAMETER	COMPONENTS SPACING A (LEAD TO LEAD)	INSIDE TAPE SPACING "B"	CUMULATIVE PITCH TOLERANCE
0 mm to 5 mm (0.0" to 0.197")	5.0 mm ± 0.5 mm (0.197" ± 0.020")	26 mm + 1.5 mm/- 0.0 mm (1.024" + 0.059"/- 0.0")	Not to exceed 1.5 mm (0.059") over 6 consecutive components
0 mm to 5 mm (0.0" to 0.197")	5.0 mm ± 0.5 mm (0.197" ± 0.020")	52.4 mm + 1.5 mm/- 0.4 mm (2.062" + 0.059"/- 0.016")	
5.01 mm to 10 mm (0.197" to 0.394")	10 mm ± 0.5 mm (0.394" ± 0.020")	52.4 mm + 1.5 mm/- 0.4 mm (2.062" + 0.059"/- 0.016")	



DIMENSIONS in millimeters (inches)

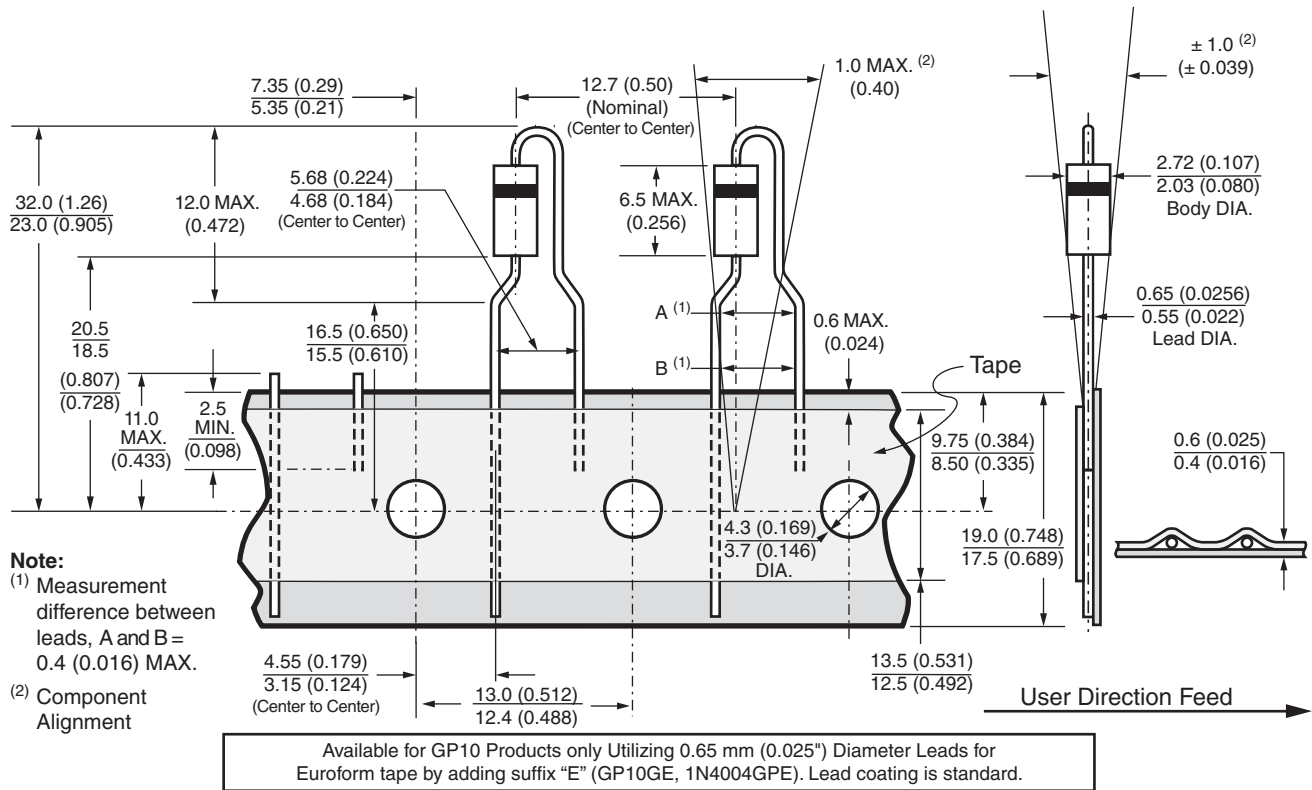

Fig. 3 - Euroform

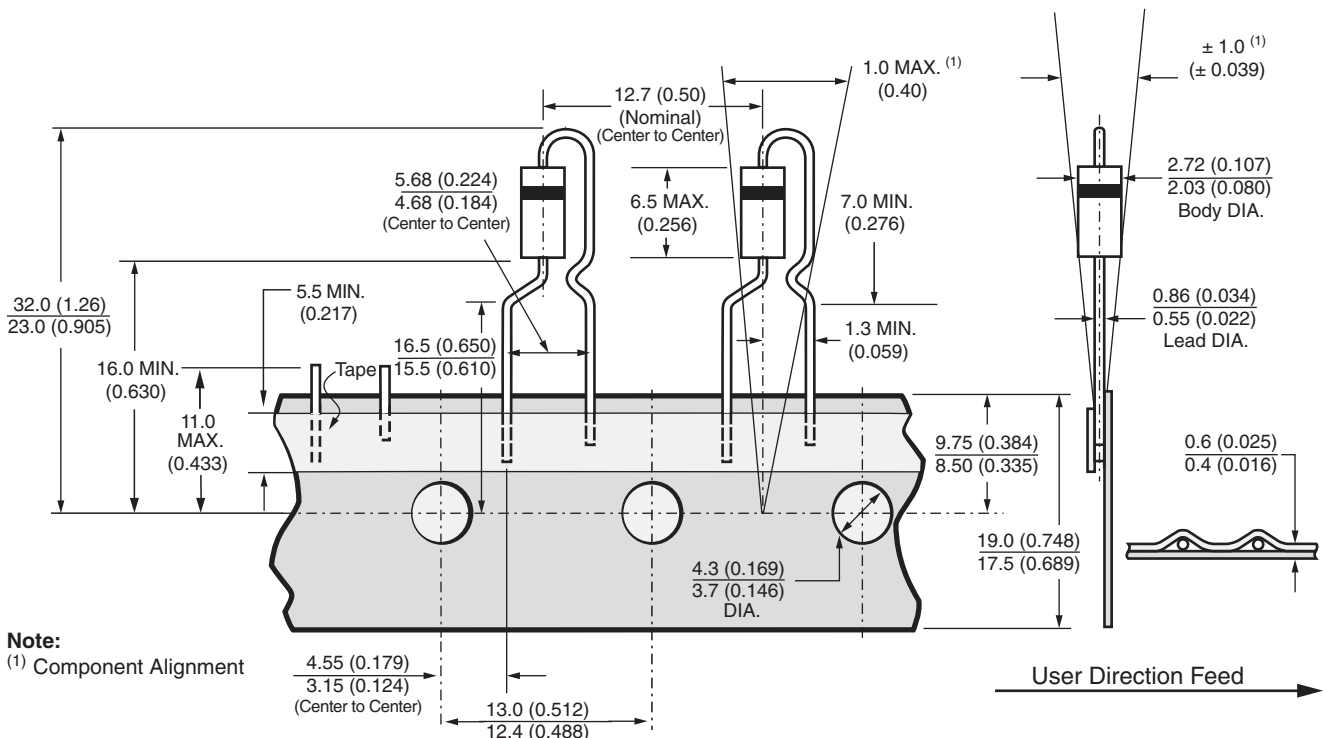
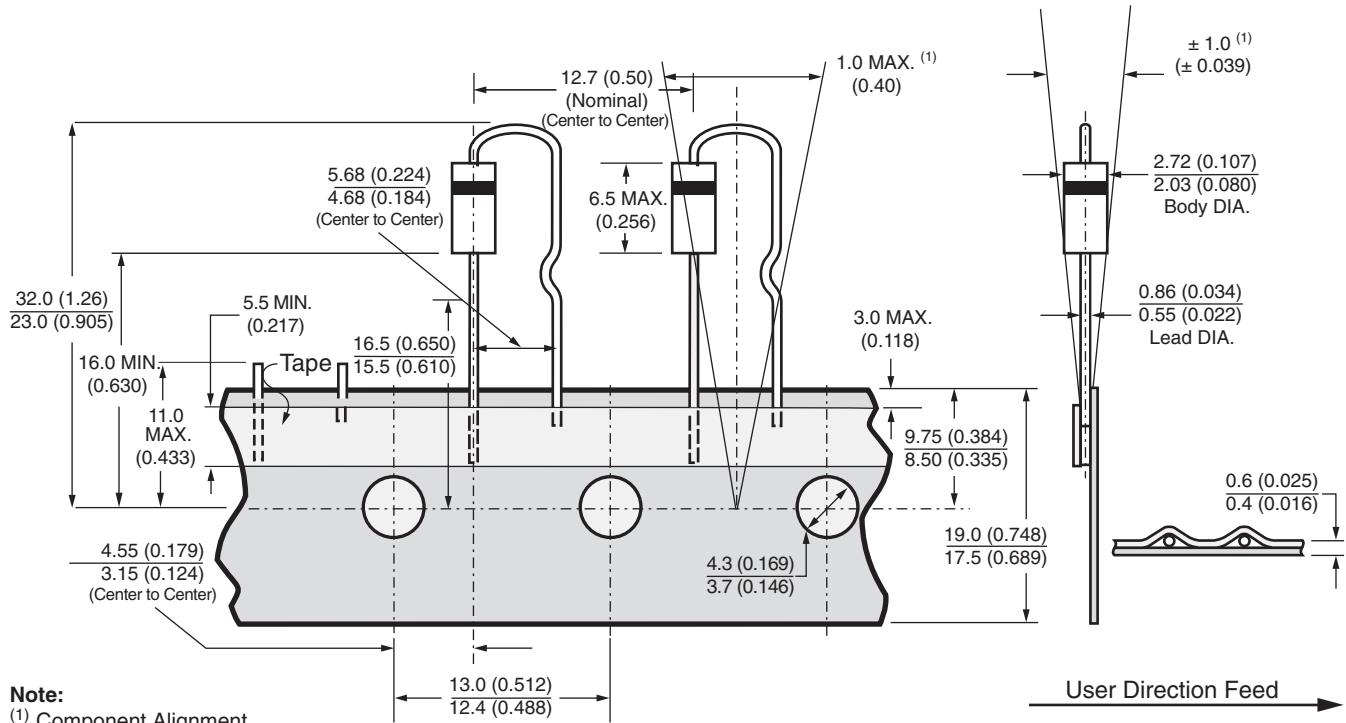

Fig. 4 - Panasert



DIMENSIONS in millimeters (inches)



Note:
(1) Component Alignment

Available only for GP10 style products utilizing 0.65 mm (0.025") or 0.76 mm (0.030") diameter leads for Panasert and Avisert tape. Lead coating is available on GP10 products only.

Standard Polarity Cathode Oriented Away from Sprocket Holes (Optional Polarity Cathode Oriented Toward Sprocket Holes)

Fig. 5 - Avisert

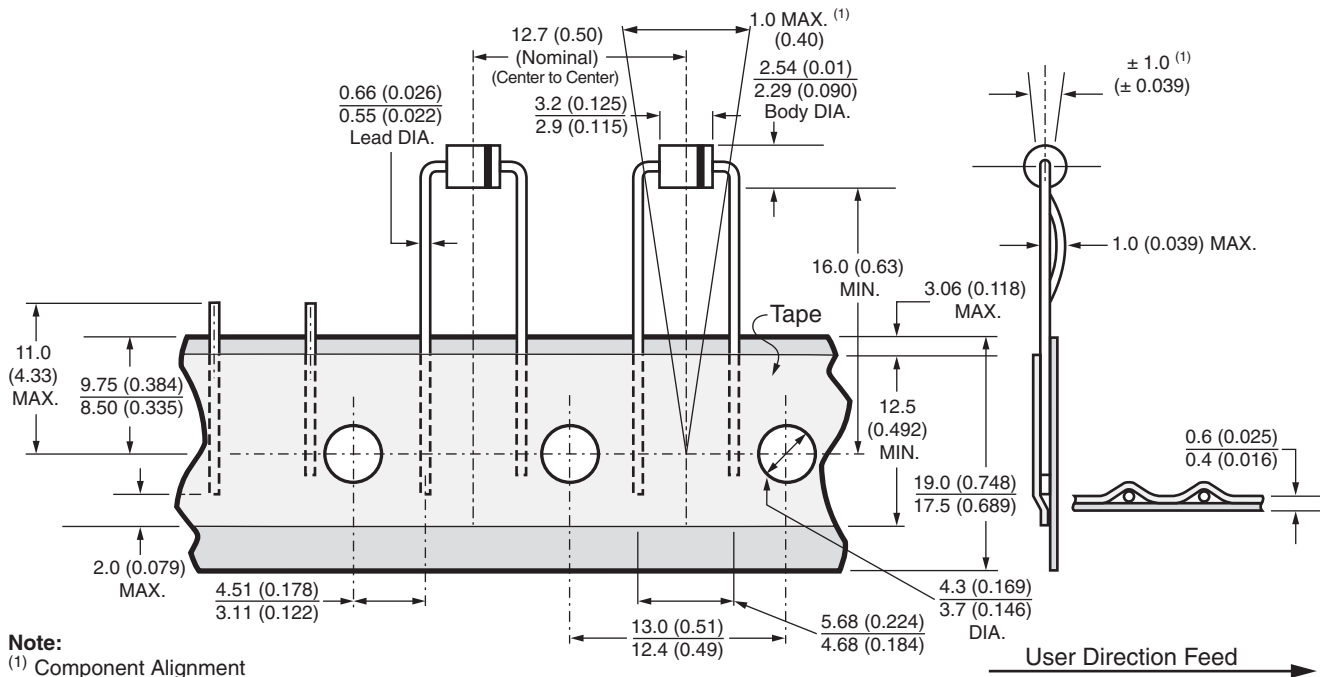

Note:
(1) Component Alignment

Available only for MPG06 Product in Ammo Pack in Accordance with EIA Standard RS-468-A Utilizing 0.61 mm (0.024") Diameter Leads. Maximum Cumulative Pitch Tolerance: 1.0 mm (0.039")/20 Pitch.

Fig. 6 - Pseudo Radial

RADIAL TAPE PACKAGING

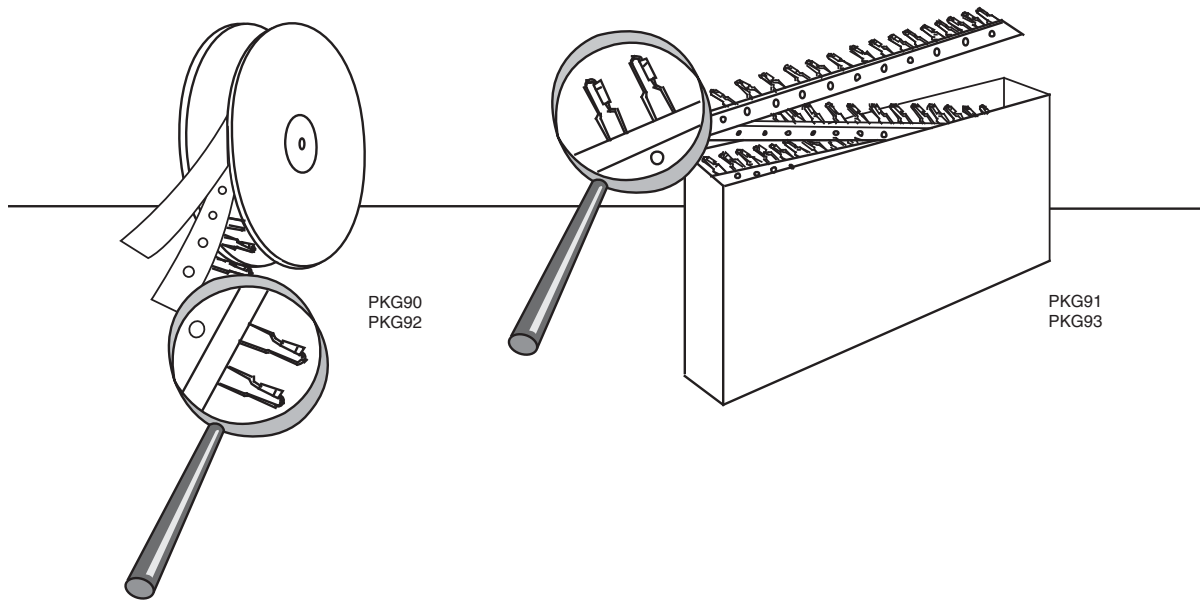

Fig. 7 and Fig. 8 - Reel and Ammo Box Packaging

PREFERRED PACKAGE CODE	
EUROFORM	PKG90, PKG91, PKG92, PKG93

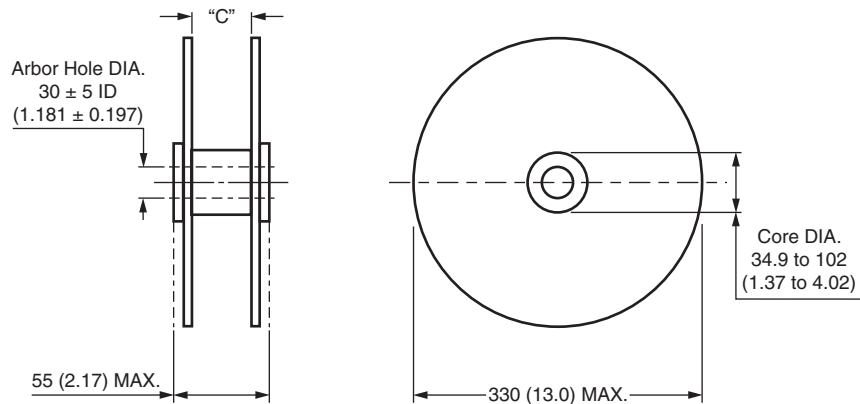

Fig. 9 - Reel Dimensions

Notes

- "C" dimension between the reel flanges shall be governed by the overall width of the taped components and shall be 1.5 mm (0.057") to 8.0 mm (0.315") greater than the overall width
- All leaded devices are packaged in accordance with EIA standard RS-468-A specification and are available on reel or in fan fold box (ammo pack)
- All dimensions are in millimeters and (inches). The above packaging is only available from Taiwan.

SURFACE MOUNT TAPE AND REEL PACKAGING

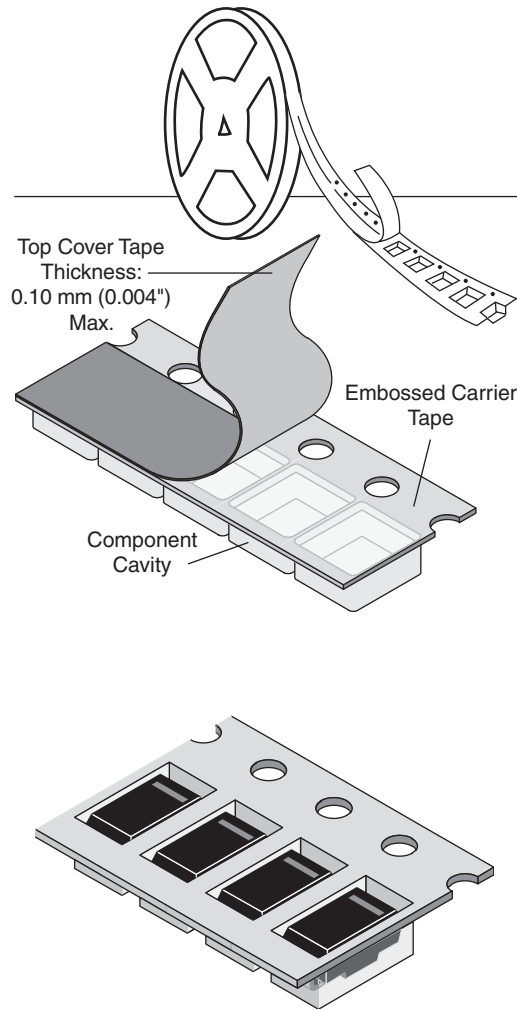

Fig. 10

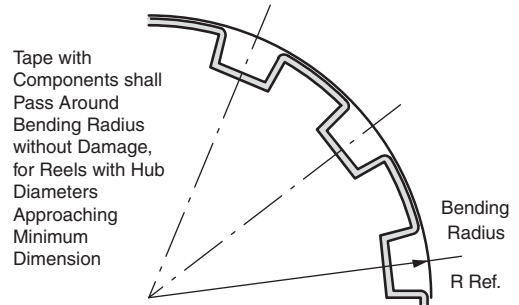

Fig. 11

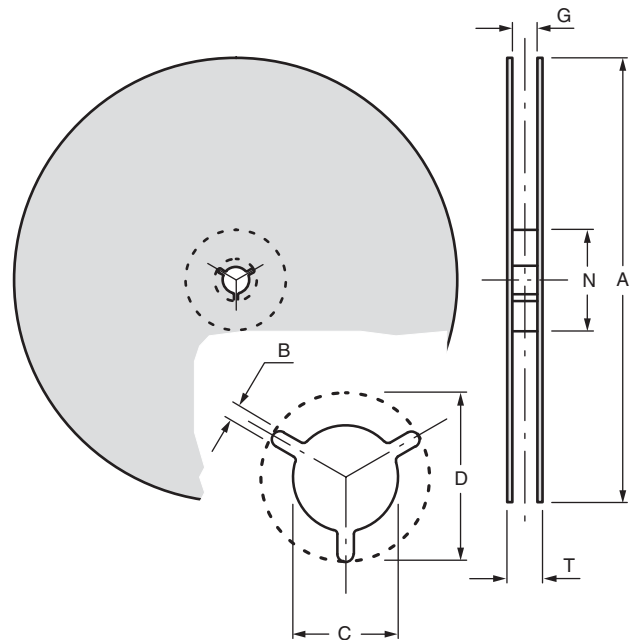

Fig. 12

DIMENSIONS in millimeters (inches)							
TAPE SIZE	A MAX.	B MIN.	C	D MIN.	N MIN.	G MAX.	T MAX.
8 mm (0.315)	330 ± 2.0 (13.0 ± 0.079) 178 ± 2.0 (7.0 ± 0.079)	1.5 (0.059)	13.0 ± 0.20 (0.51 ± 0.0008)	20.2 (0.795)	50 (1.97)	9.9 (0.389)	14.4 (0.567)
12 mm (0.472)	330 ± 2.0 (13.0 ± 0.079) 178 ± 2.0 (7.0 ± 0.079)	1.5 (0.059)	13.0 ± 0.20 (0.51 ± 0.0008)	20.2 (0.795)	50 (1.97)	14.4 (0.567)	18.4 (0.724)
16 mm (0.630)	330 ± 2.0 (13.0 ± 0.079) 178 ± 2.0 (7.0 ± 0.079)	1.5 (0.059)	13.0 ± 0.20 (0.51 ± 0.0008)	20.2 (0.795)	50 (1.97)	18.4 (0.724)	22.4 (0.802)
24 mm (0.945)	330 ± 2.0 (13.0 ± 0.079) 178 ± 2.0 (7.0 ± 0.079)	1.5 (0.059)	13.0 ± 0.20 (0.51 ± 0.0008)	20.2 (0.795)	50 (1.97)	26.4 (1.039)	30.4 (1.197)

SURFACE MOUNT TAPE AND REEL PACKAGING

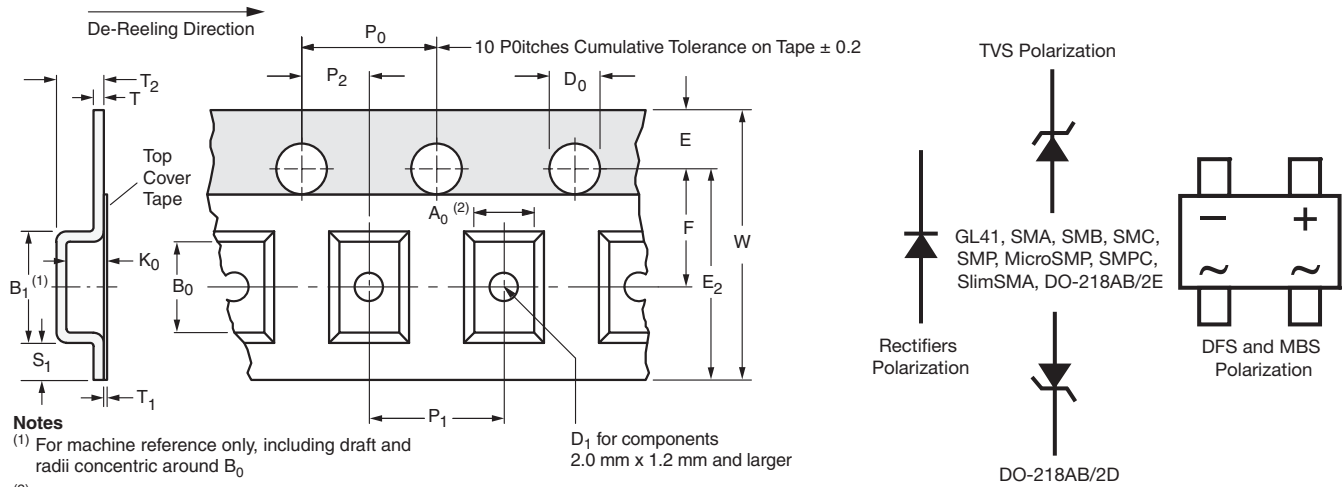

Fig. 13

8 mm, 12 mm, 16 mm, AND 24 mm EMBOSSED TAPE in millimeters (inches)								
TAPE SIZE	D_0	E_1	P_0	P_2	A_0, B_0, K_0	S_1 MIN.	T MAX.	T_1 MAX.
8 mm, 12 mm	1.5 ± 0.1 (0.059 \pm 0.004)	1.75 ± 0.1 (0.069 \pm 0.004)	4.0 ± 0.1 (0.157 \pm 0.004)	2.0 ± 0.05 (0.79 \pm 0.002)	(1)	0.6 (0.024)	0.600 (0.024)	0.1 (0.004)
16 mm, 24 mm				2.0 ± 0.1 (0.79 \pm 0.004)				

DIMENSIONS in millimeters (inches)									
CASE TYPE	TAPE SIZE	B_1 MAX.	D_1 MIN.	E_2 MAX.	F	P_1	R REF.	T_2 MAX.	W
DO-213AA (GL34)	8 (0.315)	4.2 (0.165)	1.0 (0.39)	6.25 (0.246)	3.5 ± 0.05 (0.138 \pm 0.002)	4.0 ± 0.10 (0.57 \pm 0.004)	25 (0.984)	2.4 (0.094)	8.0 ± 0.30 (0.315 \pm 0.012)
MicroSMP		3.28 (0.129)		6.05 (0.238)				1.919 (0.076)	
DO-213AB (GL41)	12 (0.472)	8.2 (0.323)	1.5 (0.059)	10.25 (0.404)	5.5 ± 0.05 (0.217 \pm 0.002)	4.0 ± 0.10 (0.57 \pm 0.004)	30 (1.181)	4.5 (0.177)	12.0 ± 0.30 (0.472 \pm 0.012)
DO-214BA (GF1)								3.25 (0.128)	
DO-214AC(SMA)								2.64 (0.104)	
DO-220AA (SMP)								1.84 (0.072)	
TO-277A (SMPC)								1.43 (0.056)	
DO-214AA (SMB)/ DO-215AA (SMBG)								2.77 (0.109)	
DO-214AB (SMC)/ DO-215AB (SMCG)								2.64 (0.104)	
DFS	16 (0.630)	12.1 (0.476)	1.5 (0.059)	14.25 (0.561)	7.5 ± 0.05 (0.295 \pm 0.002)	4.0 ± 0.10 (0.157 \pm 0.001)	30 (1.181)	3.91 (0.154)	16.0 ± 0.2 (0.630 \pm 0.008)
TO-263AB DO-218AB								5.31 (0.209)	
SMPD								2.35 (0.093)	
DO-221AC (SlimSMA)	12 (0.472)	6.2 (0.244)	1.5 (0.059)	10.25 (0.404)	5.5 ± 0.05 (0.217 \pm 0.002)	4.0 ± 0.10 (0.157 \pm 0.001)	30 (1.181)	1.53 (0.060)	12.0 ± 0.3 (0.472 \pm 0.012)

Notes

- (1) A_0 , B_0 , and K_0 are determined by the maximum dimensions of the component size. The clearance between the component and the cavity must be within 0.05 mm (0.002") min. to 0.5 mm (0.02") max. for 8 mm tape and 12 mm tape, 0.15 mm (0.006") min. to 0.90 mm (0.035") max. for 16 mm tape and 0.15 mm (0.006") min. to 1.0 mm (0.59") max. for 24 mm tape.
- (2) All surface mount components are packed in accordance with EIA standard 481-C