

1. Overview

1.1 Features

The M16C/63 Group microcomputer (MCU) incorporates the M16C/60 Series CPU core and flash memory, employing sophisticated instructions for a high level of efficiency. This MCU has 1 MB of address space (expandable to 4 MB), and it is capable of executing instructions at high speed. In addition, the CPU core boasts a multiplier for high-speed operation processing.

This MCU consumes low power, and supports operating modes that allow additional power control. The MCU also uses an anti-noise configuration to reduce emissions of electromagnetic noise and is designed to withstand electromagnetic interference (EMI). By integrating many of the peripheral functions, including the multifunction timer and serial interface, the number of system components has been reduced.

1.1.1 Applications

This MCU can be used in audio components, cameras, televisions, household appliances, office equipment, communication devices, mobile devices, industrial equipment, and other applications.

1.2 Specifications

The M16C/63 Group includes 100-pin and 80-pin packages. Table 1.1 to Table 1.4 list specifications.

Table 1.1 Specifications for the 100-Pin Package (1/2)

Item	Function	Description
CPU	Central processing unit	M16C/60 Series core (multiplier: 16 bit × 16 bit → 32 bit, multiply and accumulate instruction: 16 bit × 16 bit + 32 bit → 32 bit) <ul style="list-style-type: none"> • Number of basic instructions: 91 • Minimum instruction execution time: 50.0 ns (f(BCLK) = 20 MHz, VCC1 = VCC2 = 2.7 to 5.5 V) 100.0 ns (f(BCLK) = 10 MHz, VCC1 = VCC2 = 2.1 to below 2.7 V) 200.0 ns (f(BCLK) = 5 MHz, VCC1 = VCC2 = 1.8 V) • Operating modes: Single-chip, memory expansion, and microprocessor
Memory	ROM, RAM, data flash	See Table 1.5 "Product List".
Voltage Detection	Voltage detector	<ul style="list-style-type: none"> • Power-on reset • 3 voltage detection points (detection level of voltage detection 0 and 1 selectable)
Clock	Clock generator	<ul style="list-style-type: none"> • 4 circuits: Main clock, sub clock, low-speed on-chip oscillator (125 kHz), high-speed on-chip oscillator (40 MHz ±10%) • Oscillation stop detection: Main clock oscillation stop/restart detection function • Frequency divider circuit: Divide ratio selectable from 1, 2, 4, 8, and 16 Sub clock frequency divider circuit: Divide ratio selectable from 1 and 2 • Power saving features: Wait mode, stop mode • Real-time clock
External Bus Expansion	Bus memory expansion	<ul style="list-style-type: none"> • Address space: 1 MB • External bus interface: 0 to 8 waits inserted, 4 chip select outputs, memory area expansion function (expandable to 4 MB), 3 V and 5 V interfaces • Bus format: Separate bus or multiplexed bus selectable, data bus width selectable (8 or 16 bits), number of address buses selectable (12, 16, or 20)
I/O Ports	Programmable I/O ports	<ul style="list-style-type: none"> • CMOS I/O ports: 85 (selectable pull-up resistors) • N-channel open drain ports: 3
Interrupts		<ul style="list-style-type: none"> • Interrupt vectors: 70 • External interrupt inputs: 17 ($\overline{\text{NMI}}$, $\overline{\text{INT}} \times 8$, key input × 8) • Interrupt priority levels: 7
Watchdog Timer		15-bit timer × 1 (with prescaler) Automatic reset start function selectable
DMA	DMAC	<ul style="list-style-type: none"> • 4 channels, cycle steal mode • Trigger sources: 43 • Transfer modes: 2 (single transfer, repeat transfer)

Table 1.2 Specifications for the 100-Pin Package (2/2)

Item	Function	Description
Timers	Timer A	16-bit timer × 5 Timer mode, event counter mode, one-shot timer mode, pulse width modulation (PWM) mode Event counter two-phase pulse signal processing (two-phase encoder input) × 3 Programmable output mode × 3
	Timer B	16-bit timer × 6 Timer mode, event counter mode, pulse period measurement mode, pulse width measurement mode
	Three-phase motor control timer functions	<ul style="list-style-type: none"> • Three-phase inverter control (timer A1, timer A2, timer A4, timer B2) • On-chip dead time timer
	Real-time clock	<ul style="list-style-type: none"> • Count: seconds, minutes, hours, days of the week, months, years • Periodic interrupt: 0.25 s, 0.5 s • Automatic correction function
	PWM function	8 bits × 2
	Remote control signal receiver	<ul style="list-style-type: none"> • 2 circuits • 4 wave pattern matchings (differentiate wave pattern for headers, data 0, data 1, and special data) • 6-byte receive buffer (1 circuit only) • Operating frequency of 32 kHz
Serial Interface	UART0 to UART2, UART5 to UART7	Clock synchronous/asynchronous × 6 channels I ² C-bus, IEBus, special mode 2 SIM (UART2)
	SI/O3, SI/O4	Clock synchronization only × 2 channels
Multi-master I ² C-bus Interface		1 channel
CEC Functions (2)		CEC transmit/receive, arbitration lost detection, ACK automatic output, operation frequency of 32 kHz
A/D Converter		10-bit resolution × 26 channels, including sample and hold function Conversion time: 2.15 μs
D/A Converter		8-bit resolution × 2 circuits
CRC Calculator		CRC-CCITT ($X^{16} + X^{12} + X^5 + 1$), CRC-16 ($X^{16} + X^{15} + X^2 + 1$) compliant
Flash Memory		<ul style="list-style-type: none"> • Program and erase power supply voltage: 2.7 to 5.5 V • Program and erase cycles: 1,000 times (program ROM 1, program ROM 2), 10,000 times (data flash) • Program security: ROM code protect, ID code check
Debug Functions		On-chip debug, on-board flash rewrite, address match interrupt × 4
Operation Frequency/Supply Voltage		5 MHz/VCC1 = 1.8 to 5.5 V, VCC2 = 1.8 V to VCC1 10 MHz/VCC1 = 2.1 to 5.5 V, VCC2 = 2.1 V to VCC1 20 MHz/VCC1 = 2.7 to 5.5 V, VCC2 = 2.7 V to VCC1
Current Consumption		Described in Electrical Characteristics
Operating Temperature		-20°C to 85°C, -40°C to 85°C (1)
Package		100-pin QFP: PRQP0100JD-B (Previous package code: 100P6F-A) 100-pin LQFP: PLQP0100KB-A (Previous package code: 100P6Q-A) 100-pin LGA: PTLG0100KA-A (Previous package code: 100F0M)

Notes:

1. See Table 1.5 "Product List" for the operating temperature.
2. The CEC function indicates circuitry which supports the transmission and reception of CEC signals standardized by the High-Definition Multimedia Interface (HDMI). HDMI and High-Definition Multimedia Interface are registered trademarks of HDMI Licensing, LLC.

Table 1.3 Specifications for the 80-Pin Package (1/2)

Item	Function	Description
CPU	Central processing unit	M16C/60 Series core (multiplier: 16 bit × 16 bit → 32 bit, multiply and accumulate instruction: 16 bit × 16 bit + 32 bit → 32 bit) <ul style="list-style-type: none"> • Number of basic instructions: 91 • Minimum instruction execution time: 50.0 ns (f(BCLK) = 20 MHz, VCC1 = 2.7 to 5.5 V) 100.0 ns (f(BCLK) = 10 MHz, VCC1 = 2.1 to below 2.7 V) 200.0 ns (f(BCLK) = 5 MHz, VCC1 = 1.8 V) • Operating mode: Single-chip
Memory	ROM, RAM, data flash	See Table 1.5 "Product List".
Voltage Detection	Voltage detector	<ul style="list-style-type: none"> • Power-on reset • 3 voltage detection points (detection level of voltage detection 0 and 1 selectable)
Clock	Clock generator	<ul style="list-style-type: none"> • 4 circuits: Main clock, sub clock, low-speed on-chip oscillator (125 kHz), high-speed on-chip oscillator (40 MHz ±10%) • Oscillation stop detection: Main clock oscillation stop/restart detection function • Frequency divider circuit: Divide ratio selectable from 1, 2, 4, 8, and 16 Sub clock frequency divider circuit: Divide ratio selectable from 1 and 2 • Power saving features: Wait mode, stop mode • Real-time clock
External Bus Expansion	Bus memory expansion	None
I/O Ports	Programmable I/O ports	<ul style="list-style-type: none"> • CMOS I/O ports: 68 (selectable pull-up resistors) • N-channel open drain ports: 3
Interrupts		<ul style="list-style-type: none"> • Interrupt vectors: 70 • External interrupt inputs: 14 ($\overline{\text{NMI}}$, $\overline{\text{INT}} \times 5$, key input × 8) • Interrupt priority levels: 7
Watchdog Timer		15-bit timer × 1 (with prescaler) Automatic reset start function selectable
DMA	DMAC	<ul style="list-style-type: none"> • 4 channels, cycle steal mode • Trigger sources: 43 • Transfer modes: 2 (single transfer, repeat transfer)

Table 1.4 Specifications for the 80-Pin Package (2/2)

Item	Function	Description
Timers	Timer A	16-bit timer × 5 Timer mode × 5 Event counter mode, one-shot timer mode, pulse width modulation (PWM) mode × 3 Event counter two-phase pulse signal processing (two-phase encoder input) × 2 Programmable output mode × 1
	Timer B	16-bit timer × 6 Timer mode × 6 Event counter mode, pulse period measurement mode, pulse width measurement mode × 5
	Three-phase motor control timer functions	None
	Real-time clock	<ul style="list-style-type: none"> Count: seconds, minutes, hours, days of the week, months, years Periodic interrupt: 0.25 s, 0.5 s Automatic correction function
	PWM function	8 bits × 2
	Remote control signal receiver	<ul style="list-style-type: none"> 2 circuits 4 wave pattern matchings (differentiate wave pattern for headers, data 0, data 1, and special data) 6-byte receive buffer (1 circuit only) Operating frequency of 32 kHz
Serial Interface	UART0 to UART2, UART5	Clock synchronous/asynchronous × 3 channels I ² C-bus, IEBus, special mode 2 Clock asynchronous × 1 channel I ² C-bus, IEBus, SIM
	SI/O3, SI/O4	Clock synchronization only × 2 channels (SI/O3 is used for transmission only)
Multi-master I ² C-bus Interface		1 channel
CEC Functions (2)		CEC transmit/receive, arbitration lost detection, ACK automatic output, operation frequency of 32 kHz
A/D Converter		10-bit resolution × 26 channels, including sample and hold function Conversion time: 2.15 μs
D/A Converter		8-bit resolution × 2 circuits
CRC Calculator		CRC-CCITT ($X^{16} + X^{12} + X^5 + 1$), CRC-16 ($X^{16} + X^{15} + X^2 + 1$) compliant
Flash Memory		<ul style="list-style-type: none"> Program and erase power supply voltage: 2.7 to 5.5 V Program and erase cycles: 1,000 times (program ROM 1, program ROM 2), 10,000 times (data flash) Program security: ROM code protect, ID code check
Debug Functions		On-chip debug, on-board flash rewrite, address match interrupt × 4
Operation Frequency/Supply Voltage		5 MHz/VCC1 = 1.8 to 5.5 V 10 MHz/VCC1 = 2.1 to 5.5 V 20 MHz/VCC1 = 2.7 to 5.5 V
Current Consumption		Described in Electrical Characteristics
Operating Temperature		-20°C to 85°C, -40°C to 85°C (1)
Package		80-pin LQFP: PLQP0080KB-A (Previous package code: 80P6Q-A)

Notes:

- See Table 1.5 "Product List" for the operating temperature.
- The CEC function indicates circuitry which supports the transmission and reception of CEC signals standardized by the High-Definition Multimedia Interface (HDMI). HDMI and High-Definition Multimedia Interface are registered trademarks of HDMI Licensing, LLC.

1.3 Product List

Table 1.5 lists product information. Figure 1.1 shows the Part No., with Memory Size and Package, and Figure 1.2 and Figure 1.3 shows the Marking Diagram (Top View).

Table 1.5 Product List

As of November, 2012

Part No.	ROM Capacity			RAM Capacity	Package Code	Remarks				
	Program ROM 1	Program ROM 2	Data flash							
R5F363A6NFA	128 KB	16 KB	4 KB x 2 blocks	12 KB	PRQP0100JD-B	Operating temperature -20°C to 85°C				
R5F363A6NFB					PLQP0100KB-A					
R5F363A6NLG					PTLG0100KA-A					
R5F363B6NFE					256 KB	16 KB	4 KB x 2 blocks	20 KB	PLQP0080KB-A	Operating temperature -40°C to 85°C
R5F363A6DFA									PRQP0100JD-B	
R5F363A6DFB									PLQP0100KB-A	
R5F363B6DFE	384 KB	16 KB	4 KB x 2 blocks	31 KB	PLQP0080KB-A	Operating temperature -20°C to 85°C				
R5F363AENFA					PRQP0100JD-B					
R5F363AENFB					PLQP0100KB-A					
R5F363AENLG					PTLG0100KA-A					
R5F363BENFE					512 KB	16 KB	4 KB x 2 blocks	31 KB	PLQP0080KB-A	Operating temperature -40°C to 85°C
R5F363AEDFA									PRQP0100JD-B	
R5F363AEDFB	PLQP0100KB-A									
R5F363BEDFE	512 KB	16 KB	4 KB x 2 blocks	31 KB	PLQP0080KB-A	Operating temperature -20°C to 85°C				
R5F363AKNFA					PRQP0100JD-B					
R5F363AKNFB					PLQP0100KB-A					
R5F363AKNLG					PTLG0100KA-A					
R5F363AKDFA					Operating temperature -40°C to 85°C					
R5F363AKDFB						PLQP0100KB-A				
R5F363AMNFA	Operating temperature -40°C to 85°C									
R5F363AMNFB		PRQP0100JD-B								
R5F363AMNLG		PLQP0100KB-A								
R5F363AMDFA		PTLG0100KA-A								
R5F363AMDFB		PRQP0100JD-B								
		PLQP0100KB-A								

(D): Under development

(P): Planning

Previous package codes are as follows:

PRQP0100JD-B: 100P6F-A

PLQP0100KB-A: 100P6Q-A

PTLG0100KA-A: 100F0M

PLQP0080KB-A: 80P6Q-A

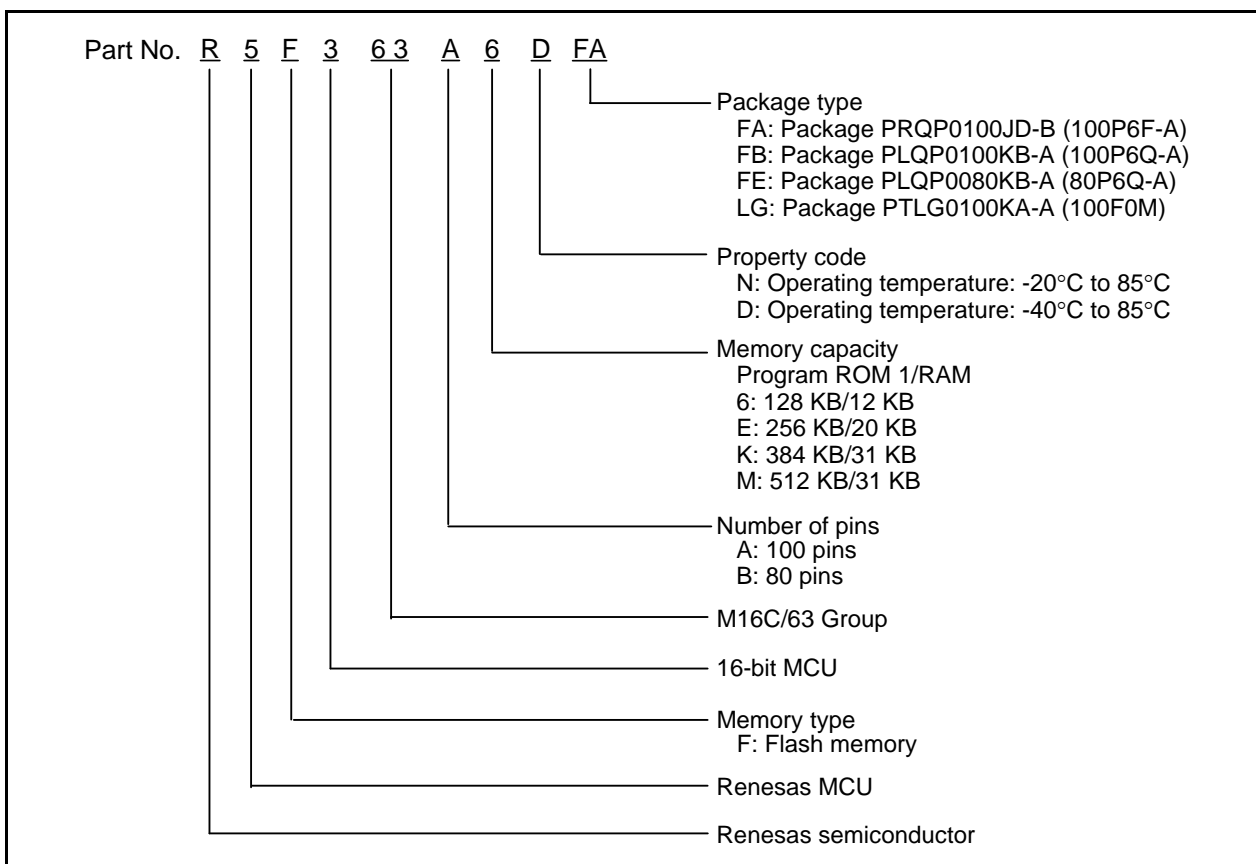

Figure 1.1 Part No., with Memory Size and Package

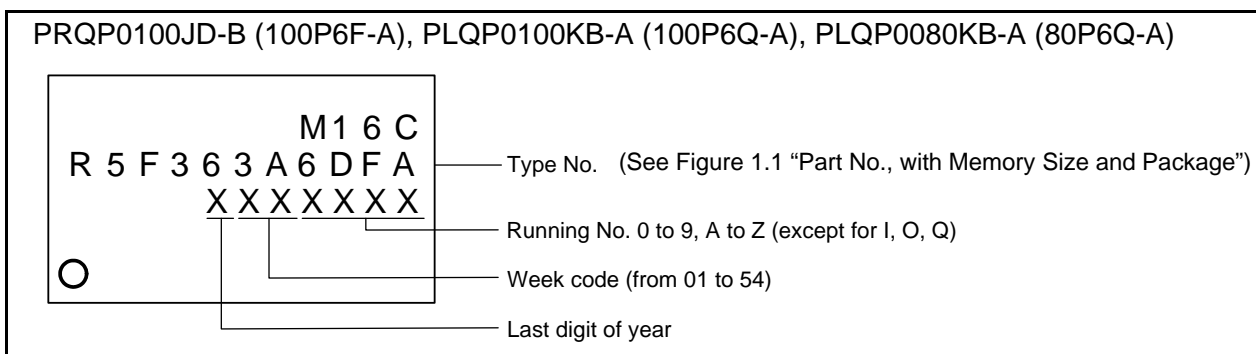

Figure 1.2 Marking Diagram (Top View) (1/2)

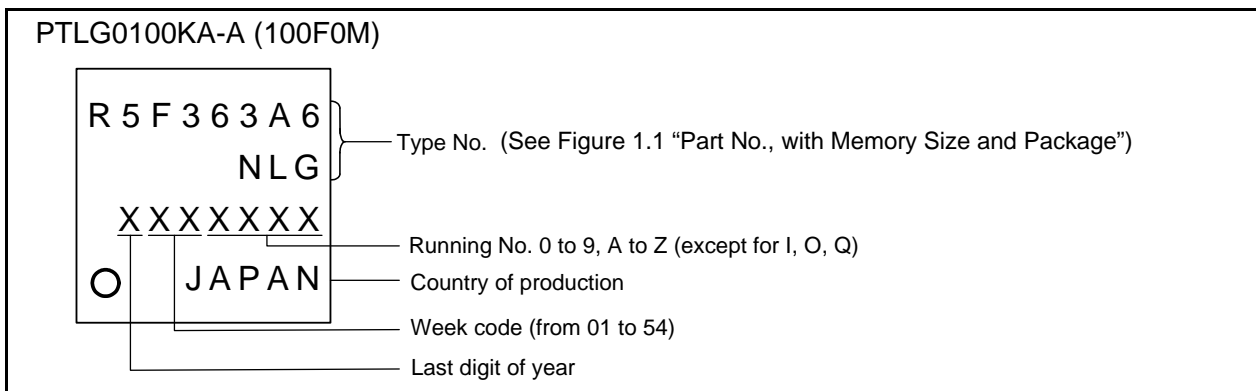

Figure 1.3 Marking Diagram (Top View) (2/2)

1.4 Block Diagram

Figure 1.4 and Figure 1.5 show block diagrams.

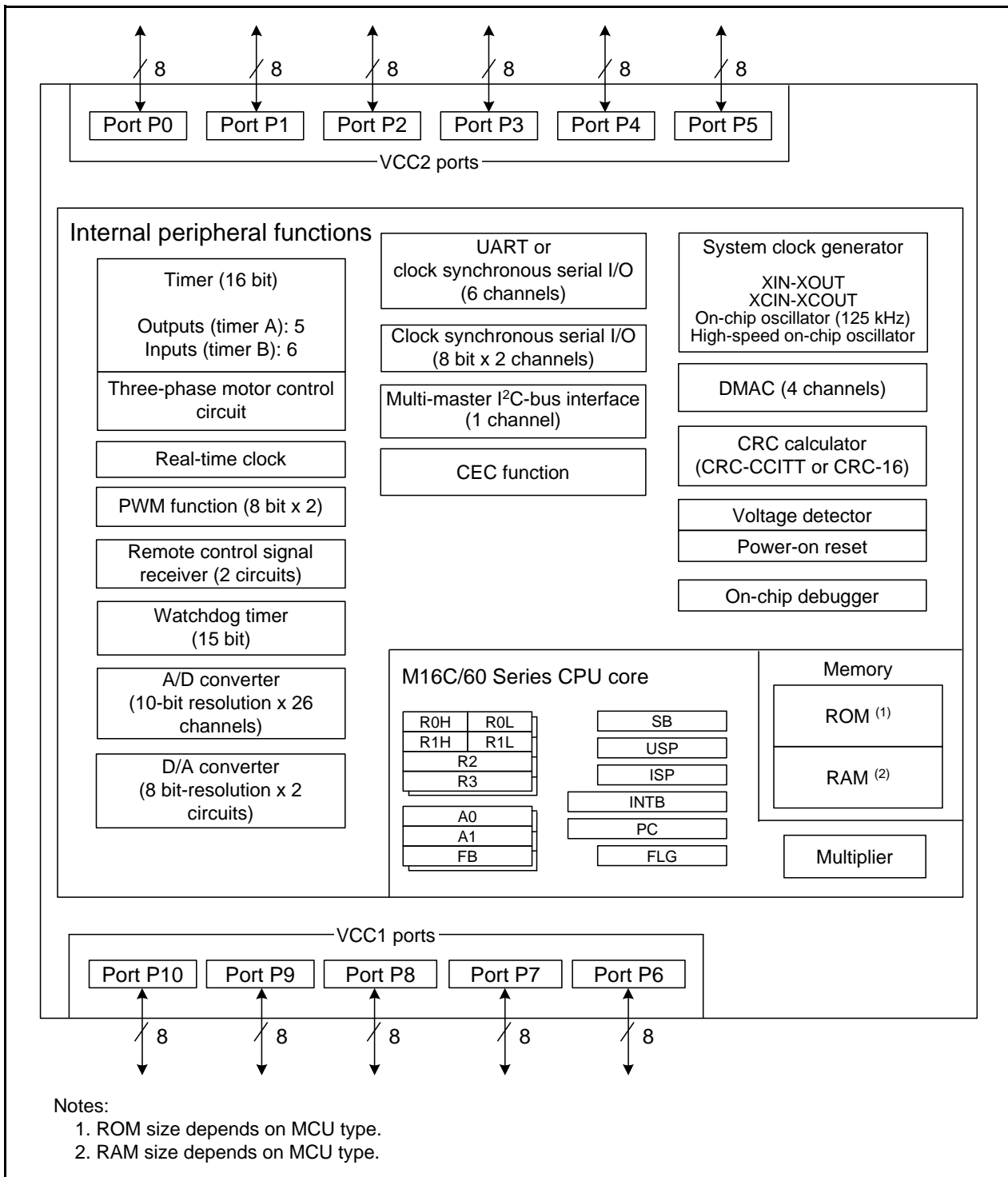

Figure 1.4 Block Diagram for the 100-Pin Package

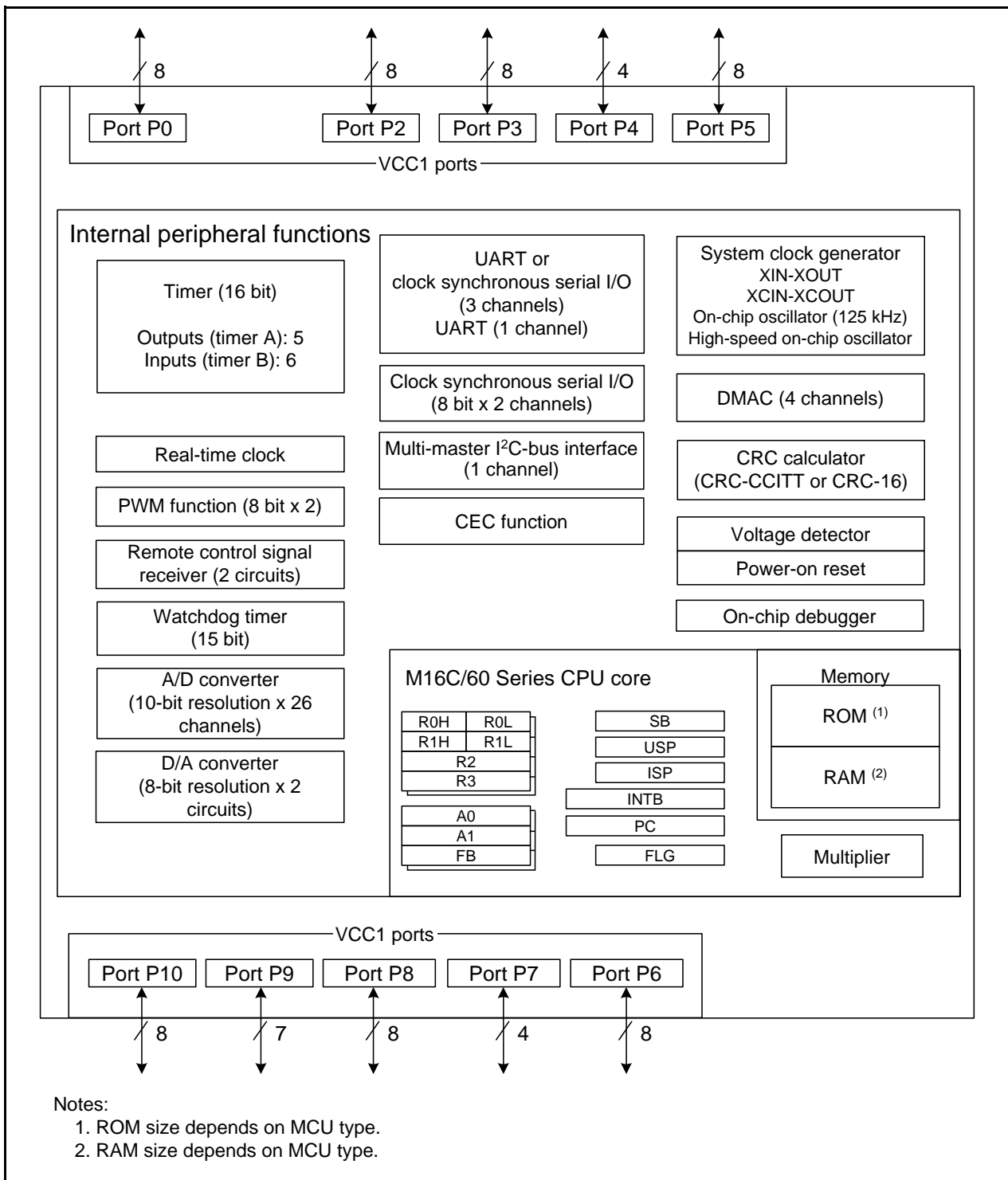

Figure 1.5 Block Diagram for the 80-Pin Package

1.5 Pin Assignments

Figure 1.6 to Figure 1.9 show pin assignments. Table 1.6 to Table 1.9 list pin names.

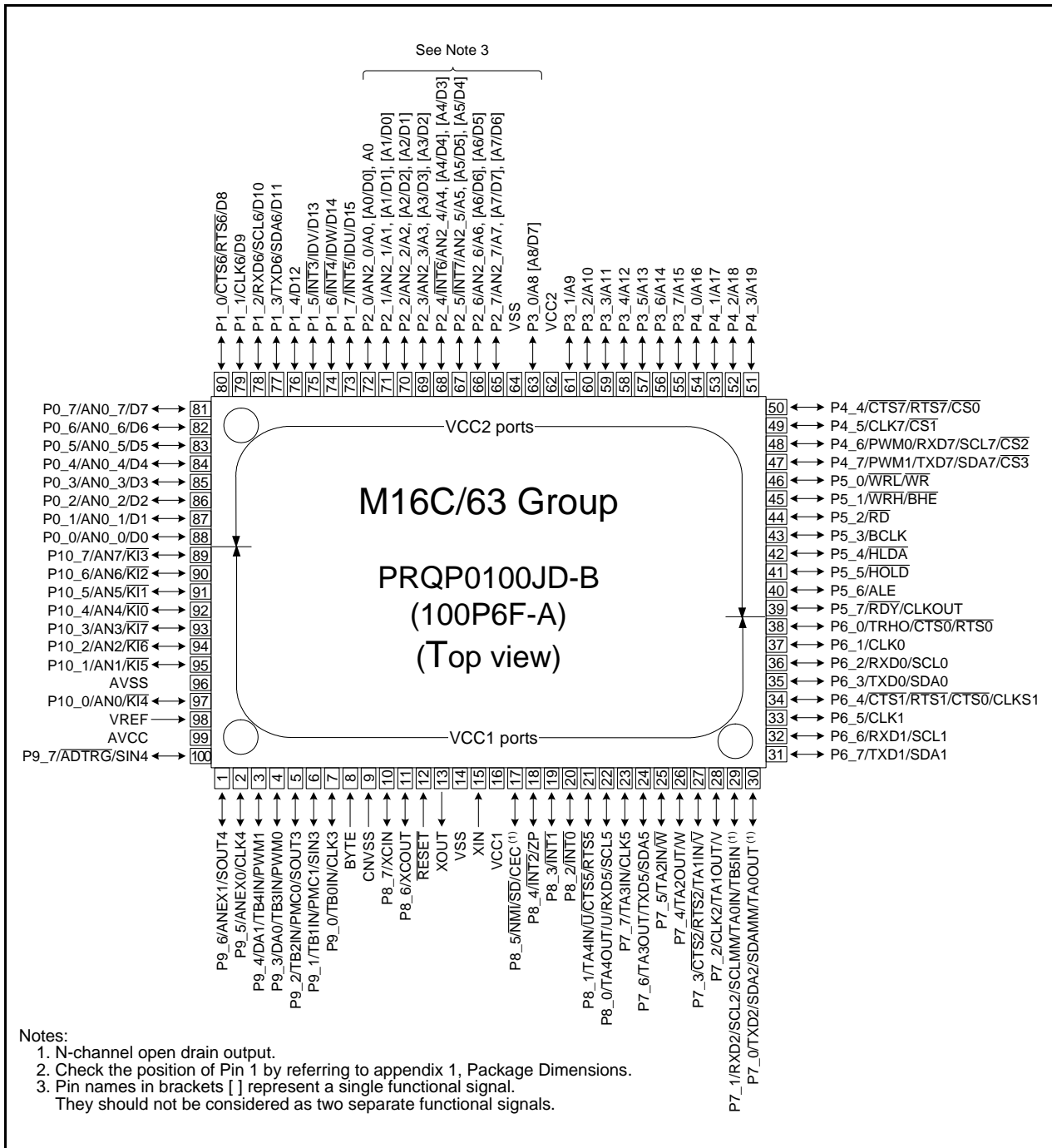

Figure 1.6 Pin Assignment for the 100-Pin Package

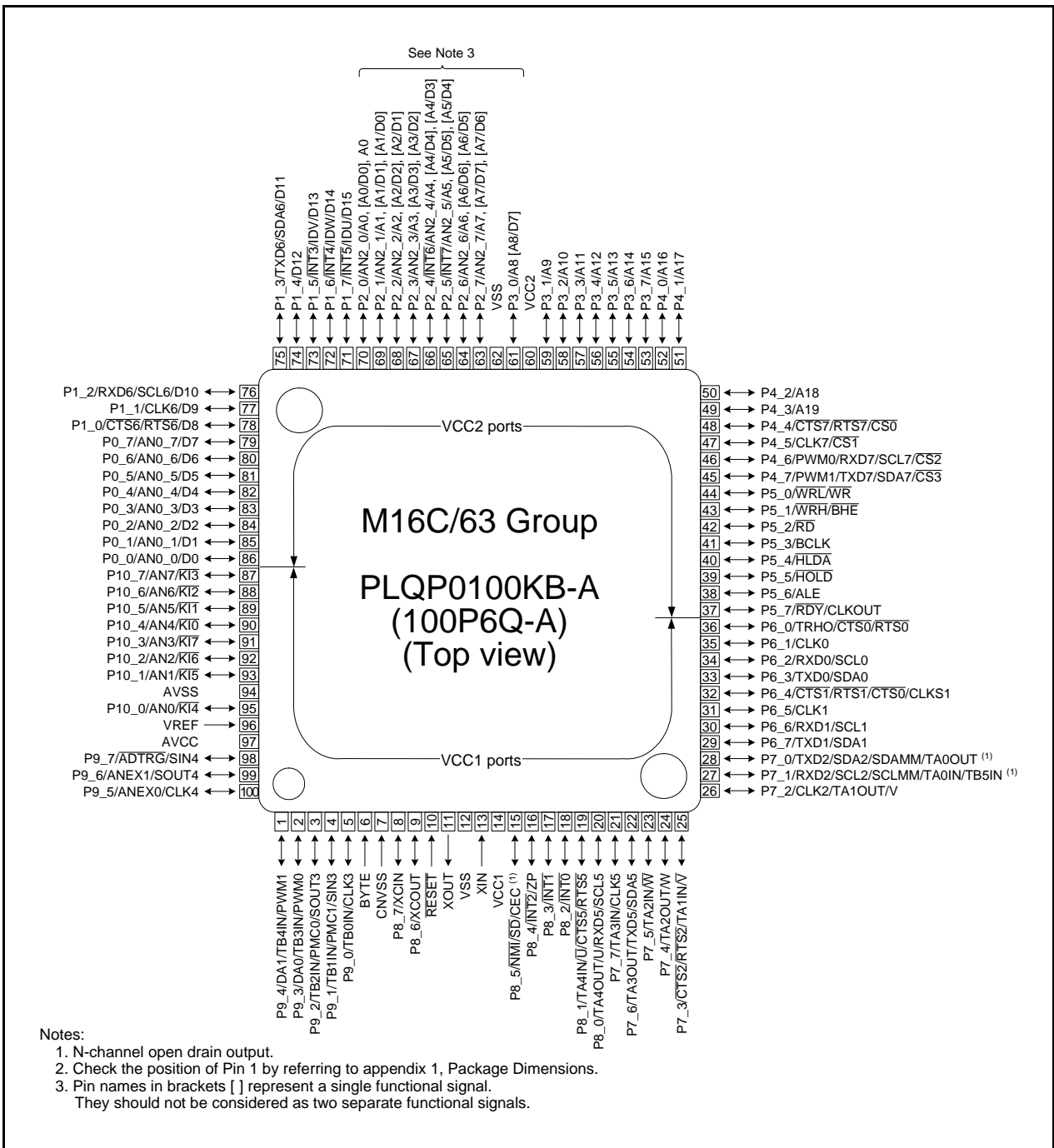

Figure 1.7 Pin Assignment for the 100-Pin Package

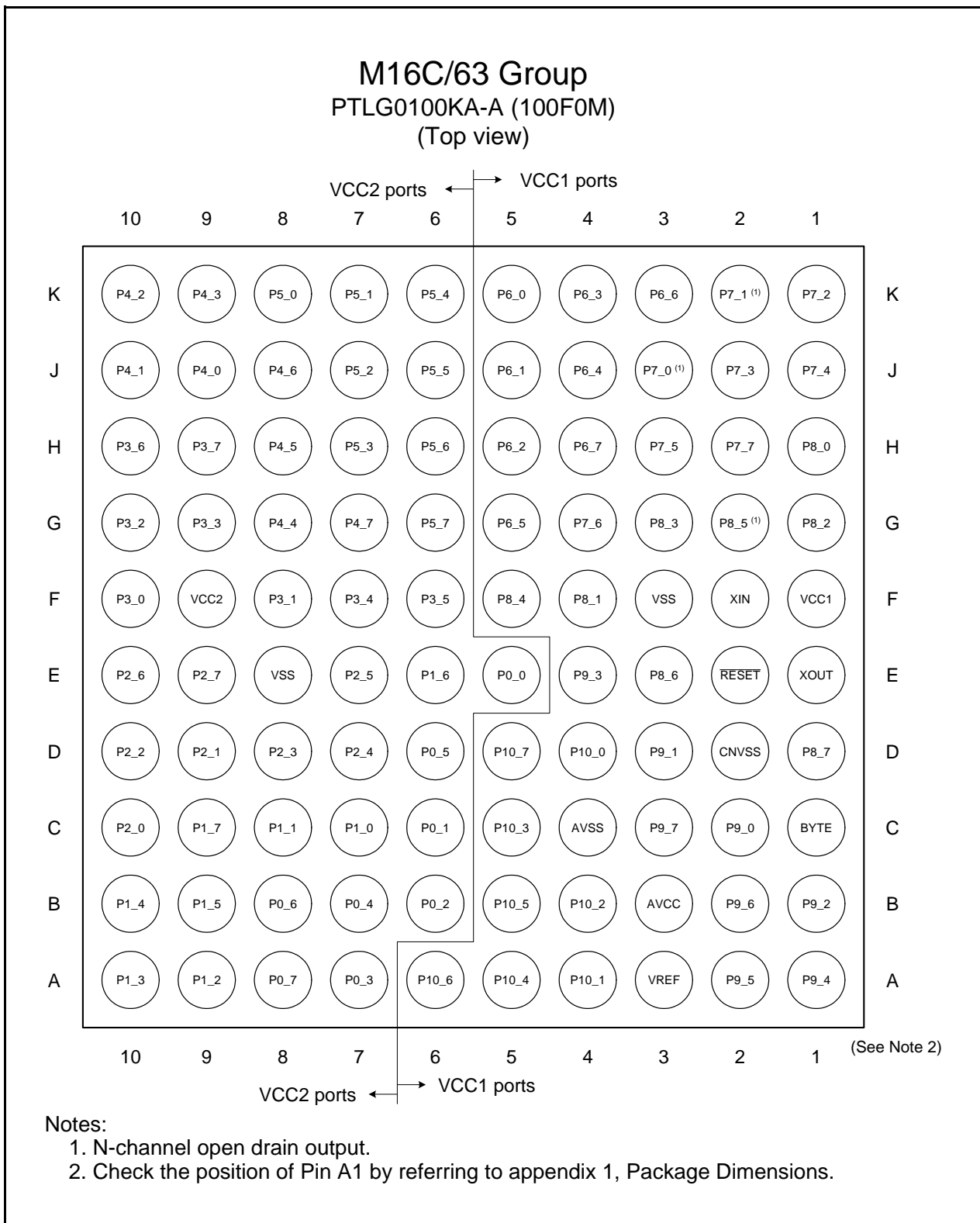

Figure 1.8 Pin Assignment for the 100-Pin Package

Table 1.6 Pin Names for the 100-Pin Package (1/2)

Pin No.			Control Pin	Port	I/O Pin for Peripheral Function				Bus Control Pin
FA	FB	LG			Interrupt	Timer	Serial interface	A/D converter, D/A converter	
1	99	B2		P9_6			SOUT4	ANEX1	
2	100	A2		P9_5			CLK4	ANEX0	
3	1	A1		P9_4		TB4IN/PWM1		DA1	
4	2	E4		P9_3		TB3IN/PWM0		DA0	
5	3	B1		P9_2		TB2IN/PMC0	SOUT3		
6	4	D3		P9_1		TB1IN/PMC1	SIN3		
7	5	C2		P9_0		TB0IN	CLK3		
8	6	C1	BYTE						
9	7	D2	CNVSS						
10	8	D1	XCIN	P8_7					
11	9	E3	XCOUT	P8_6					
12	10	E2	RESET						
13	11	E1	XOUT						
14	12	F3	VSS						
15	13	F2	XIN						
16	14	F1	VCC1						
17	15	G2		P8_5	$\overline{\text{NMI}}$	$\overline{\text{SD}}$	CEC		
18	16	F5		P8_4	$\overline{\text{INT2}}$	ZP			
19	17	G3		P8_3	$\overline{\text{INT1}}$				
20	18	G1		P8_2	$\overline{\text{INT0}}$				
21	19	F4		P8_1		TA4IN/ $\overline{\text{U}}$	$\overline{\text{CTS5/RTS5}}$		
22	20	H1		P8_0		TA4OUT/ $\overline{\text{U}}$	RXD5/SCL5		
23	21	H2		P7_7		TA3IN	CLK5		
24	22	G4		P7_6		TA3OUT	TXD5/SDA5		
25	23	H3		P7_5		TA2IN/ $\overline{\text{W}}$			
26	24	J1		P7_4		TA2OUT/ $\overline{\text{W}}$			
27	25	J2		P7_3		TA1IN/ $\overline{\text{V}}$	$\overline{\text{CTS2/RTS2}}$		
28	26	K1		P7_2		TA1OUT/ $\overline{\text{V}}$	CLK2		
29	27	K2		P7_1		TA0IN/TB5IN	RXD2/SCL2/SCLMM		
30	28	J3		P7_0		TA0OUT	TXD2/SDA2/SDAMM		
31	29	H4		P6_7			TXD1/SDA1		
32	30	K3		P6_6			RXD1/SCL1		
33	31	G5		P6_5			CLK1		
34	32	J4		P6_4			$\overline{\text{CTS1/RTS1/CTS0/CLKS1}}$		
35	33	K4		P6_3			TXD0/SDA0		
36	34	H5		P6_2			RXD0/SCL0		
37	35	J5		P6_1			CLK0		
38	36	K5		P6_0		TRHO	$\overline{\text{CTS0/RTS0}}$		
39	37	G6	CLKOUT	P5_7					$\overline{\text{RDY}}$
40	38	H6		P5_6					ALE
41	39	J6		P5_5					HOLD
42	40	K6		P5_4					HLDA
43	41	H7		P5_3					BCLK
44	42	J7		P5_2					$\overline{\text{RD}}$
45	43	K7		P5_1					WRH/BHE
46	44	K8		P5_0					WRL/WR
47	45	G7		P4_7		PWM1	TXD7/SDA7		$\overline{\text{CS3}}$
48	46	J8		P4_6		PWM0	RXD7/SCL7		$\overline{\text{CS2}}$
49	47	H8		P4_5			CLK7		$\overline{\text{CS1}}$
50	48	G8		P4_4			$\overline{\text{CTS7/RTS7}}$		$\overline{\text{CS0}}$

Table 1.7 Pin Names for the 100-Pin Package (2/2)

Pin No.			Control Pin	Port	I/O Pin for Peripheral Function				Bus Control Pin
FA	FB	LG			Interrupt	Timer	Serial interface	A/D converter, D/A converter	
51	49	K9		P4_3				A19	
52	50	K10		P4_2				A18	
53	51	J10		P4_1				A17	
54	52	J9		P4_0				A16	
55	53	H9		P3_7				A15	
56	54	H10		P3_6				A14	
57	55	F6		P3_5				A13	
58	56	F7		P3_4				A12	
59	57	G9		P3_3				A11	
60	58	G10		P3_2				A10	
61	59	F8		P3_1				A9	
62	60	F9	VCC2						
63	61	F10		P3_0				A8, [A8/D7]	
64	62	E8	VSS						
65	63	E9		P2_7			AN2_7	A7, [A7/D7], [A7/D6]	
66	64	E10		P2_6			AN2_6	A6, [A6/D6], [A6/D5]	
67	65	E7		P2_5	INT7		AN2_5	A5, [A5/D5], [A5/D4]	
68	66	D7		P2_4	INT6		AN2_4	A4, [A4/D4], [A4/D3]	
69	67	D8		P2_3			AN2_3	A3, [A3/D3], [A3/D2]	
70	68	D10		P2_2			AN2_2	A2, [A2/D2], [A2/D1]	
71	69	D9		P2_1			AN2_1	A1, [A1/D1], [A1/D0]	
72	70	C10		P2_0			AN2_0	A0, [A0/D0], A0	
73	71	C9		P1_7	INT5	IDU		D15	
74	72	E6		P1_6	INT4	IDW		D14	
75	73	B9		P1_5	INT3	IDV		D13	
76	74	B10		P1_4				D12	
77	75	A10		P1_3			TXD6/SDA6	D11	
78	76	A9		P1_2			RXD6/SCL6	D10	
79	77	C8		P1_1			CLK6	D9	
80	78	C7		P1_0			CTS6/RTS6	D8	
81	79	A8		P0_7			AN0_7	D7	
82	80	B8		P0_6			AN0_6	D6	
83	81	D6		P0_5			AN0_5	D5	
84	82	B7		P0_4			AN0_4	D4	
85	83	A7		P0_3			AN0_3	D3	
86	84	B6		P0_2			AN0_2	D2	
87	85	C6		P0_1			AN0_1	D1	
88	86	E5		P0_0			AN0_0	D0	
89	87	D5		P10_7	K13		AN7		
90	88	A6		P10_6	K12		AN6		
91	89	B5		P10_5	K11		AN5		
92	90	A5		P10_4	K10		AN4		
93	91	C5		P10_3	K17		AN3		
94	92	B4		P10_2	K16		AN2		
95	93	A4		P10_1	K15		AN1		
96	94	C4	AVSS						
97	95	D4		P10_0	K14		AN0		
98	96	A3	VREF						
99	97	B3	AVCC						
100	98	C3		P9_7			SIN4	ADTRG	

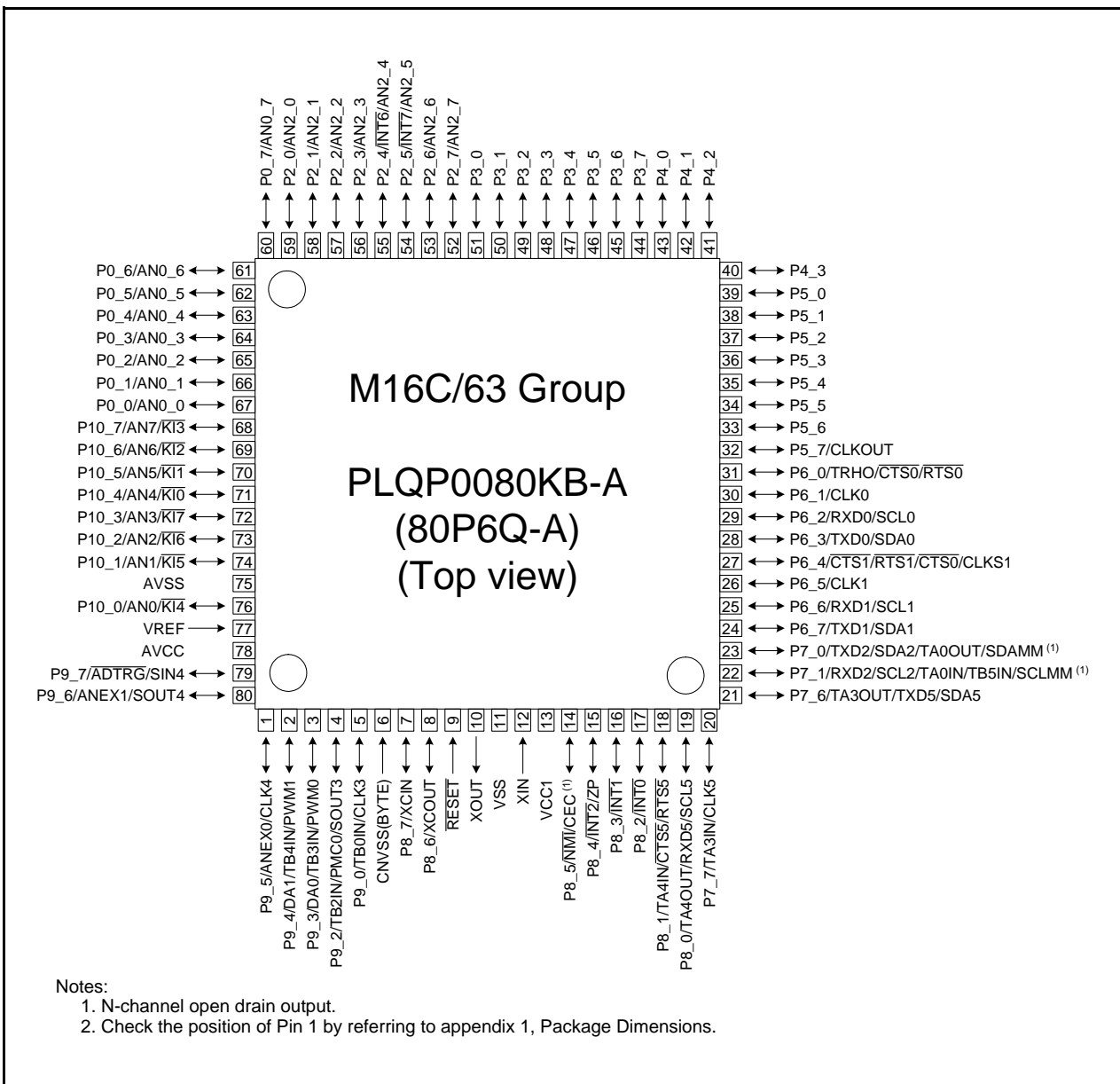

Figure 1.9 Pin Assignment for the 80-Pin Package

Table 1.8 Pin Names for the 80-Pin Package (1/2)

Pin No.	Control Pin	Port	I/O Pin for Peripheral Function			
			Interrupt	Timer	Serial interface	A/D converter, D/A converter
1		P9_5			CLK4	ANEX0
2		P9_4		TB4IN/PWM1		DA1
3		P9_3		TB3IN/PWM0		DA0
4		P9_2		TB2IN/PMC0	SOUT3	
5		P9_0		TB0IN	CLK3	
6	CNVSS					
7	XCIN	P8_7				
8	XCOUT	P8_6				
9	$\overline{\text{RESET}}$					
10	XOUT					
11	VSS					
12	XIN					
13	VCC1					
14		P8_5	$\overline{\text{NMI}}$		CEC	
15		P8_4	$\overline{\text{INT2}}$	ZP		
16		P8_3	$\overline{\text{INT1}}$			
17		P8_2	$\overline{\text{INT0}}$			
18		P8_1		TA4IN	$\overline{\text{CTS5/RTS5}}$	
19		P8_0		TA4OUT	RXD5/SCL5	
20		P7_7		TA3IN	CLK5	
21		P7_6		TA3OUT	TXD5/SDA5	
22		P7_1		TA0IN/TB5IN	RXD2/SCL2/SCLMM	
23		P7_0		TA0OUT	TXD2/SDA2/SDAMM	
24		P6_7			TXD1/SDA1	
25		P6_6			RXD1/SCL1	
26		P6_5			CLK1	
27		P6_4			$\overline{\text{CTS1/RTS1/CTS0/CLKS1}}$	
28		P6_3			TXD0/SDA0	
29		P6_2			RXD0/SCL0	
30		P6_1			CLK0	
31		P6_0		TRHO	$\overline{\text{CTS0/RTS0}}$	
32	CLKOUT	P5_7				
33		P5_6				
34		P5_5				
35		P5_4				
36		P5_3				
37		P5_2				
38		P5_1				
39		P5_0				
40		P4_3				

Table 1.9 Pin Names for the 80-Pin Package (2/2)

Pin No.	Control Pin	Port	I/O Pin for Peripheral Function			
			Interrupt	Timer	Serial interface	A/D converter, D/A converter
41		P4_2				
42		P4_1				
43		P4_0				
44		P3_7				
45		P3_6				
46		P3_5				
47		P3_4				
48		P3_3				
49		P3_2				
50		P3_1				
51		P3_0				
52		P2_7				AN2_7
53		P2_6				AN2_6
54		P2_5	$\overline{\text{INT7}}$			AN2_5
55		P2_4	$\overline{\text{INT6}}$			AN2_4
56		P2_3				AN2_3
57		P2_2				AN2_2
58		P2_1				AN2_1
59		P2_0				AN2_0
60		P0_7				AN0_7
61		P0_6				AN0_6
62		P0_5				AN0_5
63		P0_4				AN0_4
64		P0_3				AN0_3
65		P0_2				AN0_2
66		P0_1				AN0_1
67		P0_0				AN0_0
68		P10_7	$\overline{\text{KI3}}$			AN7
69		P10_6	$\overline{\text{KI2}}$			AN6
70		P10_5	$\overline{\text{KI1}}$			AN5
71		P10_4	$\overline{\text{KI0}}$			AN4
72		P10_3	$\overline{\text{KI7}}$			AN3
73		P10_2	$\overline{\text{KI6}}$			AN2
74		P10_1	$\overline{\text{KI5}}$			AN1
75	AVSS					
76		P10_0	$\overline{\text{KI4}}$			AN0
77	VREF					
78	AVCC					
79		P9_7			SIN4	ADTRG
80		P9_6			SOUT4	ANEX1

1.6 Pin Functions

Table 1.10 Pin Functions for the 100-Pin Package (1/3)

Signal Name	Pin Name	I/O	Power Supply	Description
Power supply input	VCC1, VCC2, VSS	I	-	Apply 1.8 to 5.5 V to pins VCC1 and VCC2 ($VCC1 \geq VCC2$) and 0 V to the VSS pin.
Analog power supply input	AVCC, AVSS	I	VCC1	This is the power supply for the A/D and D/A converters. Connect the AVCC pin to VCC1, and connect the AVSS pin to VSS.
Reset input	$\overline{\text{RESET}}$	I	VCC1	Driving this pin low resets the MCU.
CNVSS	CNVSS	I	VCC1	Input pin to switch processor modes. After a reset, to start operating in single-chip mode, connect the CNVSS pin to VSS via a resistor. To start operating in microprocessor mode, connect the pin to VCC1.
External data bus width select input	BYTE	I	VCC1	Input pin to select the data bus of the external area. The data bus is 16 bits when it is low, and 8 bits when it is high. This pin must be fixed either high or low. Connect the BYTE pin to VSS in single-chip mode.
Bus control pins	D0 to D7	I/O	VCC2	Inputs or outputs data (D0 to D7) while accessing an external area with a separate bus.
	D8 to D15	I/O	VCC2	Inputs or outputs data (D8 to D15) while accessing an external area with a 16-bit separate bus.
	A0 to A19	O	VCC2	Outputs address bits A0 to A19.
	A0/D0 to A7/D7	I/O	VCC2	Inputs or outputs data (D0 to D7) and outputs address bits (A0 to A7) by timesharing, while accessing an external area with an 8-bit multiplexed bus.
	A1/D0 to A8/D7	I/O	VCC2	Inputs or outputs data (D0 to D7) and outputs address bits (A1 to A8) by timesharing, while accessing an external area with a 16-bit multiplexed bus.
	$\overline{\text{CS0}}$ to $\overline{\text{CS3}}$	O	VCC2	Outputs chip-select signals $\overline{\text{CS0}}$ to $\overline{\text{CS3}}$ to specify an external area.
	$\overline{\text{WRL}}/\overline{\text{WRH}}/\overline{\text{BHE}}$ $\overline{\text{RD}}$	O	VCC2	Outputs $\overline{\text{WRL}}$, $\overline{\text{WRH}}$, ($\overline{\text{WR}}$, $\overline{\text{BHE}}$), and $\overline{\text{RD}}$ signals. $\overline{\text{WRL}}$ and $\overline{\text{WRH}}$ can be switched with $\overline{\text{BHE}}$ and $\overline{\text{WR}}$. <ul style="list-style-type: none"> • $\overline{\text{WRL}}$, $\overline{\text{WRH}}$, and $\overline{\text{RD}}$ selected If the external data bus is 16 bits, data is written to an even address in an external area when $\overline{\text{WRL}}$ is driven low. Data is written to an odd address when $\overline{\text{WRH}}$ is driven low. Data is read when $\overline{\text{RD}}$ is driven low. • $\overline{\text{WR}}$, $\overline{\text{BHE}}$, and $\overline{\text{RD}}$ selected Data is written to an external area when $\overline{\text{WR}}$ is driven low. Data in an external area is read when $\overline{\text{RD}}$ is driven low. An odd address is accessed when $\overline{\text{BHE}}$ is driven low. Select $\overline{\text{WR}}$, $\overline{\text{BHE}}$, and $\overline{\text{RD}}$ when using an 8-bit external data bus.
	ALE	O	VCC2	Outputs an ALE signal to latch the address.
	$\overline{\text{HOLD}}$	I	VCC2	$\overline{\text{HOLD}}$ input is unavailable. Connect the $\overline{\text{HOLD}}$ pin to VCC2 via a resistor (pull-up).
	$\overline{\text{HLDA}}$	O	VCC2	In a hold state, $\overline{\text{HLDA}}$ outputs a low-level signal.
	$\overline{\text{RDY}}$	I	VCC2	The MCU bus is placed in a wait state while the $\overline{\text{RDY}}$ pin is driven low.

Power supply: VCC2 is used to supply power to the external bus associated pins. The dual power supply configuration allows VCC2 to interface at a different voltage than VCC1.

Table 1.11 Pin Functions for the 100-Pin Package (2/3)

Signal Name	Pin Name	I/O	Power Supply	Description	
Main clock input	XIN	I	VCC1	I/O for the main clock oscillator. Connect a ceramic resonator or crystal between pins XIN and XOUT. ⁽¹⁾ Input an external clock to XIN pin and leave XOUT pin open.	
Main clock output	XOUT	O	VCC1		
Sub clock input	XCIN	I	VCC1	I/O for a sub clock oscillator. Connect a crystal between XCIN pin and XCOOUT pin. ⁽¹⁾ Input an external clock to XCIN pin and leave XCOOUT pin open.	
Sub clock output	XCOOUT	O	VCC1		
BCLK output	BCLK	O	VCC2	Outputs the BCLK signal.	
Clock output	CLKOUT	O	VCC2	Outputs a clock with the same frequency as f _C , f ₁ , f ₈ , or f ₃₂ .	
$\overline{\text{INT}}$ interrupt input	INT0 to INT2	I	VCC1	Input for the $\overline{\text{INT}}$ interrupt.	
	$\overline{\text{INT3}}$ to $\overline{\text{INT7}}$	I	VCC2		
$\overline{\text{NMI}}$ interrupt input	NMI	I	VCC1	Input for the $\overline{\text{NMI}}$ interrupt.	
Key input interrupt input	$\overline{\text{KI0}}$ to $\overline{\text{KI7}}$	I	VCC1	Input for the key input interrupt.	
Timer A	TA0OUT to TA4OUT	I/O	VCC1	I/O for timers A0 to A4 (TA0OUT is N-channel open drain output).	
	TA0IN to TA4IN	I	VCC1	Input for timers A0 to A4.	
	ZP	I	VCC1	Input for Z-phase.	
Timer B	TB0IN to TB5IN	I	VCC1	Input for timers B0 to B5.	
Three-phase motor control timer	U, $\overline{\text{U}}$, V, $\overline{\text{V}}$, W, $\overline{\text{W}}$	O	VCC1	Output for the three-phase motor control timer.	
	$\overline{\text{SD}}$	I	VCC1	Forced cutoff input.	
	IDU, IDV, IDW	I	VCC2	Input for the position data.	
Real-time clock output	TRHO	O	VCC1	Output for the real-time clock.	
PWM output	PWM0, PWM1	O	VCC1, VCC2	PWM output.	
Remote control signal receiver input	PMC0, PMC1	I	VCC1	Input for the remote control signal receiver.	
Serial interface UART0 to UART2, UART5 to UART7	$\overline{\text{CTS0}}$ to $\overline{\text{CTS2}}$, $\overline{\text{CTS5}}$	I	VCC1	Input pins to control data transmission.	
	$\overline{\text{CTS6}}$, $\overline{\text{CTS7}}$	I	VCC2		
	$\overline{\text{RTS0}}$ to $\overline{\text{RTS2}}$, $\overline{\text{RTS5}}$	O	VCC1	Output pins to control data reception.	
	$\overline{\text{RTS6}}$, $\overline{\text{RTS7}}$	O	VCC2		
	CLK0 to CLK2, CLK5	I/O	VCC1	Transmit/receive clock I/O.	
	CLK6, CLK7	I/O	VCC2		
	RXD0 to RXD2, RXD5	I	VCC1	Serial data input.	
	RXD6, RXD7	I	VCC2		
	TXD0 to TXD2, TXD5	O	VCC1	Serial data output. ⁽²⁾	
	TXD6, TXD7	O	VCC2		
		CLKS1	O	VCC1	Output for the transmit/receive clock multiple-pin output function.

Notes:

- Contact the manufacturer of crystal/ceramic resonator regarding the oscillation characteristics.
- TXD2, SDA2, and SCL2 are N-channel open drain output pins. TXDi, SDAi, and SCLi can be selected as CMOS output pins or N-channel open drain output pins (i = 0, 1, 5 to 7).

Table 1.12 Pin Functions for the 100-Pin Package (3/3)

Signal Name	Pin Name	I/O	Power Supply	Description
UART0 to UART2, UART5 to UART7 I ² C mode	SDA0 to SDA2, SDA5	I/O	VCC1	Serial data I/O.
	SDA6, SDA7	I/O	VCC2	
	SCL0 to SCL2, SCL5	I/O	VCC1	Transmit/receive clock I/O.
	SCL6, SCL7	I/O	VCC2	
Serial interface SI/O3, SI/O4	CLK3, CLK4	I/O	VCC1	Transmit/receive clock I/O.
	SIN3, SIN4	I	VCC1	Serial data input.
	SOUT3, SOUT4	O	VCC1	Serial data output.
Multi-master I ² C-bus interface	SDAMM	I/O	VCC1	Serial data I/O (N-channel open drain output).
	SCLMM	I/O	VCC1	Transmit/receive clock I/O (N-channel open drain output).
CEC I/O	CEC	I/O	VCC1	CEC I/O (N-channel open drain output).
Reference voltage input	VREF	I	VCC1	Reference voltage input for the A/D and D/A converters.
A/D converter	AN0 to AN7	I	VCC1	Analog input.
	AN0_0 to AN0_7 AN2_0 to AN2_7	I	VCC2	
	ADTRG	I	VCC1	External trigger input.
	ANEX0, ANEX1	I	VCC1	Extended analog input.
D/A converter	DA0, DA1	O	VCC1	Output for the D/A converter.
I/O ports	P0_0 to P0_7 P1_0 to P1_7 P2_0 to P2_7 P3_0 to P3_7 P4_0 to P4_7 P5_0 to P5_7	I/O	VCC2	8-bit CMOS I/O ports. A direction register determines whether each pin is used as an input port or an output port. A pull-up resistor may be enabled or disabled for input ports in 4-bit units.
	P6_0 to P6_7 P7_0 to P7_7 P8_0 to P8_7 P9_0 to P9_7 P10_0 to P10_7	I/O	VCC1	8-bit I/O ports having equivalent functions to P0. However, P7_0, P7_1, and P8_5 are N-channel open drain output ports. No pull-up resistor is provided. P8_5 is an input port for verifying the $\overline{\text{NMI}}$ pin level and shares a pin with $\overline{\text{NMI}}$.

Table 1.13 Pin Functions for the 80-Pin Package (1/2)

Signal Name	Pin Name	I/O	Power Supply	Description
Power supply input	VCC1, VSS	I	-	Apply 1.8 to 5.5 V to the VCC1 pin and 0 V to the VSS pin.
Analog power supply input	AVCC, AVSS	I	VCC1	This is the power supply for the A/D and D/A converters. Connect the AVCC pin to VCC1, and connect the AVSS pin to VSS.
Reset input	$\overline{\text{RESET}}$	I	VCC1	Driving this pin low resets the MCU.
CNVSS	CNVSS	I	VCC1	Input pin to switch processor modes. After a reset, to start operating in single-chip mode, connect the CNVSS pin to VSS via a resistor.
Main clock input	XIN	I	VCC1	I/O pins for the main clock oscillator. Connect a ceramic resonator or crystal between pins XIN and XOUT. ⁽¹⁾ Input an external clock to XIN pin and leave XOUT pin open.
Main clock output	XOUT	O	VCC1	
Sub clock input	XCIN	I	VCC1	I/O pins for a sub clock oscillator. Connect a crystal between XCIN pin and XCOOUT pin. ⁽¹⁾ Input an external clock to XCIN pin and leave XCOOUT pin open.
Sub clock output	XCOOUT	O	VCC1	
Clock output	CLKOUT	O	VCC1	Outputs a clock with the same frequency as f _C , f ₁ , f ₈ , or f ₃₂ .
$\overline{\text{INT}}$ interrupt input	$\overline{\text{INT0}}$ to $\overline{\text{INT2}}$	I	VCC1	Input for the $\overline{\text{INT}}$ interrupt.
	$\overline{\text{INT6}}$, $\overline{\text{INT7}}$	I	VCC1	
$\overline{\text{NMI}}$ interrupt input	$\overline{\text{NMI}}$	I	VCC1	Input for the $\overline{\text{NMI}}$ interrupt.
Key input interrupt input	$\overline{\text{KI0}}$ to $\overline{\text{KI7}}$	I	VCC1	Input for the key input interrupt.
Timer A	TA0OUT, TA3OUT, TA4OUT	I/O	VCC1	I/O for timers A0, A3, and A4 (TA0OUT is N-channel open drain output).
	TA0IN, TA3IN, TA4IN	I	VCC1	Input for timers A0, A3, and A4.
	ZP	I	VCC1	Input for Z-phase.
Timer B	TB0IN, TB2IN to TB5IN	I	VCC1	Input for timers B0, and B2 to B5.
Real-time clock output	TRHO	O	VCC1	Output for the real-time clock.
PWM output	PWM0, PWM1	O	VCC1	PWM output.
Remote control signal receiver input	PMC0	I	VCC1	Input for the remote control signal receiver.

Note:

- Contact the manufacturer of crystal/ceramic resonator regarding oscillation characteristics.

Table 1.14 Pin Functions for the 80-Pin Package (2/2)

Signal Name	Pin Name	I/O	Power Supply	Description
Serial interface UART0 to UART2, UART5	CTS0, CTS1, CTS5	I	VCC1	Input pins to control data transmission
	RTS0, RTS1, RTS5	O	VCC1	Output pins to control data reception
	CLK0, CLK1, CLK5	I/O	VCC1	Transmit/receive clock I/O.
	RXD0 to RXD2, RXD5	I	VCC1	Serial data input.
	TXD0 to TXD2, TXD5	O	VCC1	Serial data output. (1)
	CLKS1	O	VCC1	Output for the transmit/receive clock multiple-pin output function.
UART0 to UART2, UART5 I ² C mode	SDA0 to SDA2, SDA5	I/O	VCC1	Serial data I/O.
	SCL0 to SCL2, SCL5	I/O	VCC1	Transmit/receive clock I/O.
Serial interface SI/O3, SI/O4	CLK3, CLK4	I/O	VCC1	Transmit/receive clock I/O.
	SIN4	I	VCC1	Serial data input.
	SOUT3, SOUT4	O	VCC1	Serial data output.
Multi-master I ² C-bus interface	SDAMM	I/O	VCC1	Serial data I/O (N-channel open drain output).
	SCLMM	I/O	VCC1	Transmit/receive clock I/O (N-channel open drain output).
CEC I/O	CEC	I/O	VCC1	CEC I/O (N-channel open drain output).
Reference voltage input	VREF	I	VCC1	Reference voltage input for the A/D and D/A converters.
A/D converter	AN0 to AN7	I	VCC1	Analog input.
	AN0_0 to AN0_7 AN2_0 to AN2_7	I	VCC1	
	ADTRG	I	VCC1	External trigger input.
	ANEX0, ANEX1	I	VCC1	Extended analog input.
D/A converter	DA0, DA1	O	VCC1	Output for the D/A converter.
I/O ports	P0_0 to P0_7 P2_0 to P2_7 P3_0 to P3_7 P5_0 to P5_7 P6_0 to P6_7 P8_0 to P8_7 P10_0 to P10_7	I/O	VCC1	8-bit CMOS I/O ports. A direction register determines whether each pin is used as an input port or an output port. A pull-up resistor may be enabled or disabled for input ports in 4-bit units. P8_5 is N-channel open drain output port. No pull-up resistor is provided. P8_5 is an input port for verifying the $\overline{\text{NMI}}$ pin level and shares a pin with $\overline{\text{NMI}}$.
	P4_0 to P4_3 P7_0, P7_1 P7_6, P7_7 P9_0, P9_2 to P9_7	I/O	VCC1	I/O ports having equivalent functions to P0. However, P7_0 and P7_1 are N-channel open drain output ports. No pull-up resistor is provided.

Note:

1. TXD2, SDA2, and SCL2 are N-channel open drain output pins. TXDi (i = 0, 1, 5), SDAi, and SCLi can be selected as CMOS output pins or N-channel open drain output pins.

2. Central Processing Unit (CPU)

Figure 2.1 shows the CPU registers. Seven registers (R0, R1, R2, R3, A0, A1, and FB) out of 13 compose a register bank, and there are two register banks.

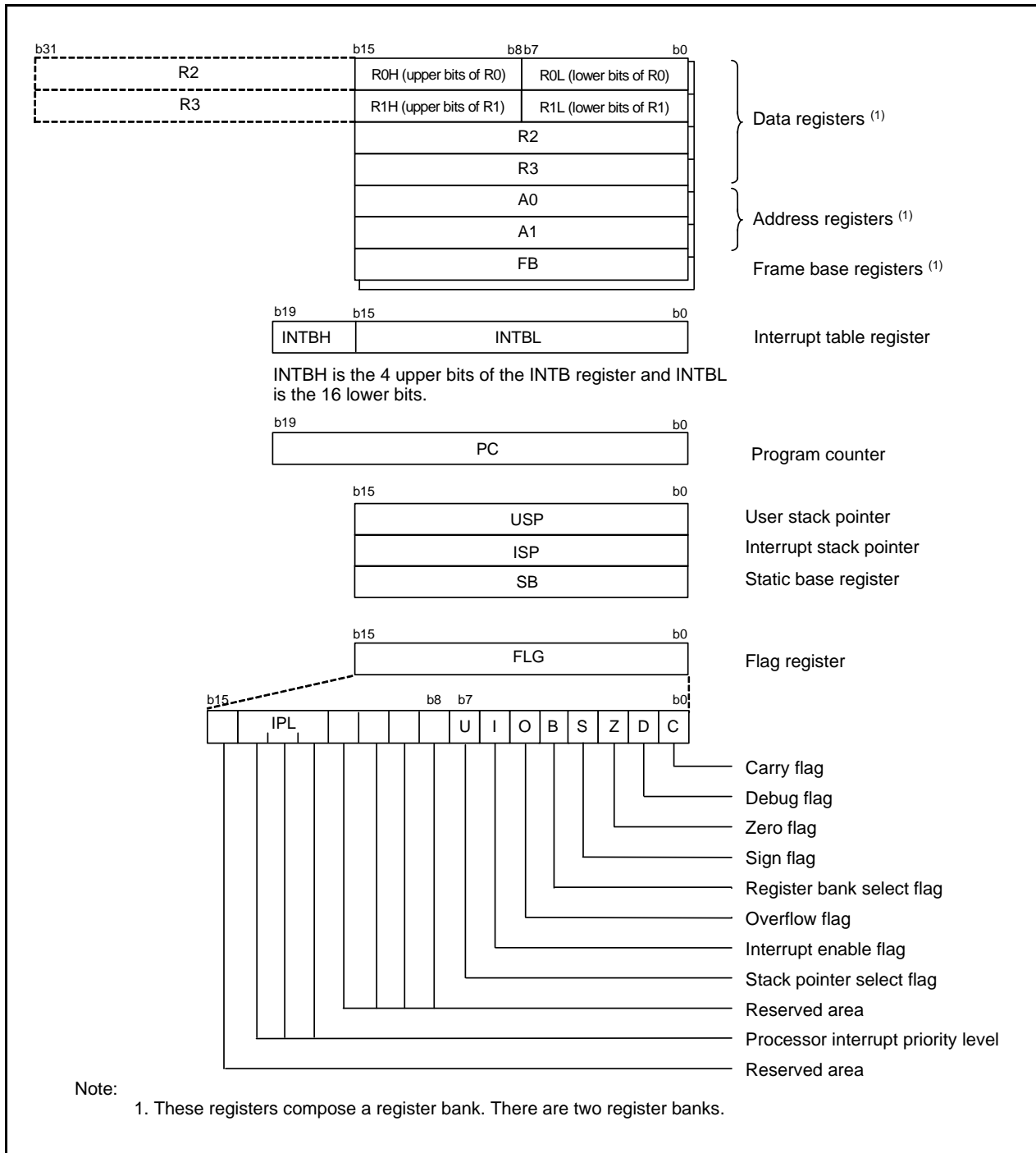

Figure 2.1 CPU Registers

2.1 Data Registers (R0, R1, R2, and R3)

R0, R1, R2, and R3 are 16-bit registers used for transfer, arithmetic, and logic operations. R0 and R1 can be split into upper (R0H/R1H) and lower (R0L/R1L) bits to be used separately as 8-bit data registers.

R0 can be combined with R2, and R3 can be combined with R1 and be used as 32-bit data registers R2R0 and R3R1, respectively.

2.2 Address Registers (A0 and A1)

A0 and A1 are 16-bit registers used for indirect addressing, relative addressing, transfer, arithmetic, and logic operations. A0 can be combined with A1 and used as a 32-bit address register (A1A0).

2.3 Frame Base Register (FB)

FB is a 16-bit register that is used for FB relative addressing.

2.4 Interrupt Table Register (INTB)

INTB is a 20-bit register that indicates the start address of a relocatable interrupt vector table.

2.5 Program Counter (PC)

The PC is 20 bits wide and indicates the address of the next instruction to be executed.

2.6 User Stack Pointer (USP) and Interrupt Stack Pointer (ISP)

The USP and ISP stack pointers (SP) are each comprised of 16 bits. The U flag is used to switch between USP and ISP.

2.7 Static Base Register (SB)

SB is a 16-bit register used for SB relative addressing.

2.8 Flag Register (FLG)

FLG is an 11-bit register that indicates the CPU state.

2.8.1 Carry Flag (C Flag)

The C flag retains a carry, borrow, or shift-out bit generated by the arithmetic/logic unit.

2.8.2 Debug Flag (D Flag)

The D flag is for debugging only. Set it to 0.

2.8.3 Zero Flag (Z Flag)

The Z flag becomes 1 when an arithmetic operation results in 0. Otherwise, it becomes 0.

2.8.4 Sign Flag (S Flag)

The S flag becomes 1 when an arithmetic operation results in a negative value. Otherwise, it becomes 0.

2.8.5 Register Bank Select Flag (B Flag)

Register bank 0 is selected when the B flag is 0. Register bank 1 is selected when this flag is 1.

2.8.6 Overflow Flag (O Flag)

The O flag becomes 1 when an arithmetic operation results in an overflow. Otherwise, it becomes 0.

2.8.7 Interrupt Enable Flag (I Flag)

The I flag enables maskable interrupts.

Maskable interrupts are disabled when the I flag is 0, and enabled when it is 1. The I flag becomes 0 when an interrupt request is accepted.

2.8.8 Stack Pointer Select Flag (U Flag)

ISP is selected when the U flag is 0. USP is selected when the U flag is 1.

The U flag becomes 0 when a hardware interrupt request is accepted, or the INT instruction of software interrupt number 0 to 31 is executed.

2.8.9 Processor Interrupt Priority Level (IPL)

IPL is 3 bits wide and assigns processor interrupt priority levels from 0 to 7.

If a requested interrupt has higher priority than IPL, the interrupt request is enabled.

2.8.10 Reserved Areas

Only set these bits to 0. The read value is undefined.

3. Address Space

3.1 Address Space

The M16C/63 Group has a 1 MB address space from 00000h to FFFFFh. Address space is expandable to 4 MB with the memory area expansion function. Addresses 40000h to BFFFFh can be used as external areas from bank 0 to bank 7. Figure 3.1 shows the Address Space. Areas that can be accessed vary depending on processor mode and the status of each control bit.

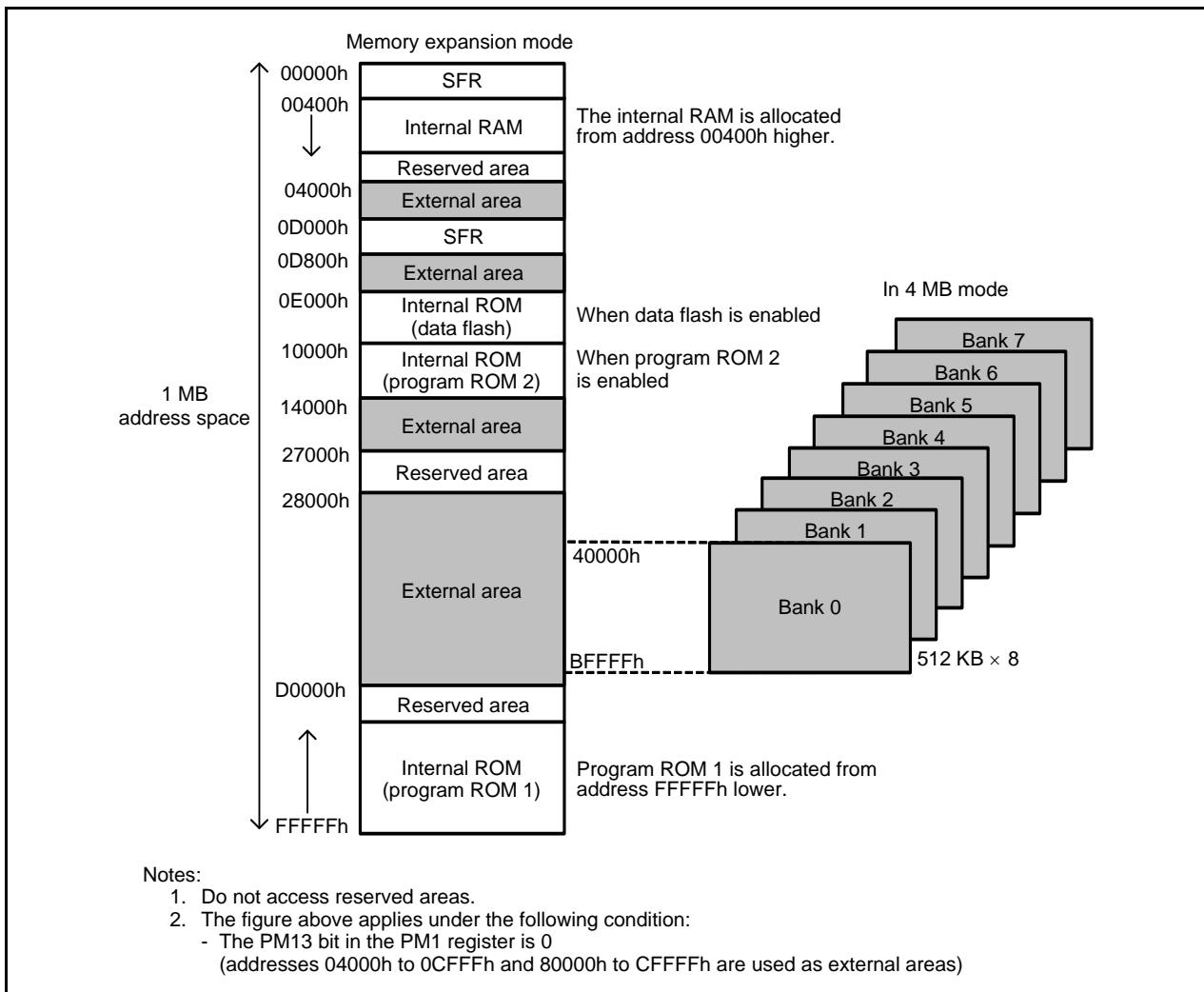

Figure 3.1 Address Space

3.2 Memory Map

Special function registers (SFRs) are allocated from address 00000h to 003FFh and from 0D000h to 0D7FFh. Peripheral function control registers are located here. All blank areas within SFRs are reserved. Do not access these areas.

Internal RAM is allocated from address 00400h and higher, with 10 KB of internal RAM allocated from 00400h to 02BFFh. Internal RAM is used not only for data storage, but also for the stack area when subroutines are called or when an interrupt request is accepted.

The internal ROM is flash memory. Three internal ROM areas are available: data flash, program ROM 1, and program ROM 2.

The data flash is allocated from 0E000h to 0FFFFh. This data flash area is mostly used for data storage, but can also store programs.

Program ROM 2 is allocated from 10000h to 13FFFh. Program ROM 1 is allocated from FFFFFh and lower, with the 64 KB program ROM 1 area allocated from address F0000h to FFFFFh.

The special page vectors are allocated from FFE00h to FFFD7h. They are used for the JMPS and JSRS instructions. Refer to the M16C/60, M16C/20, M16C/Tiny Series Software Manual for details.

The fixed vector table for interrupts is allocated from FFFDCh to FFFFFh.

The 256 bytes beginning with the start address set in the INTB register compose the relocatable vector table for interrupts.

Figure 3.2 shows the Memory Map.

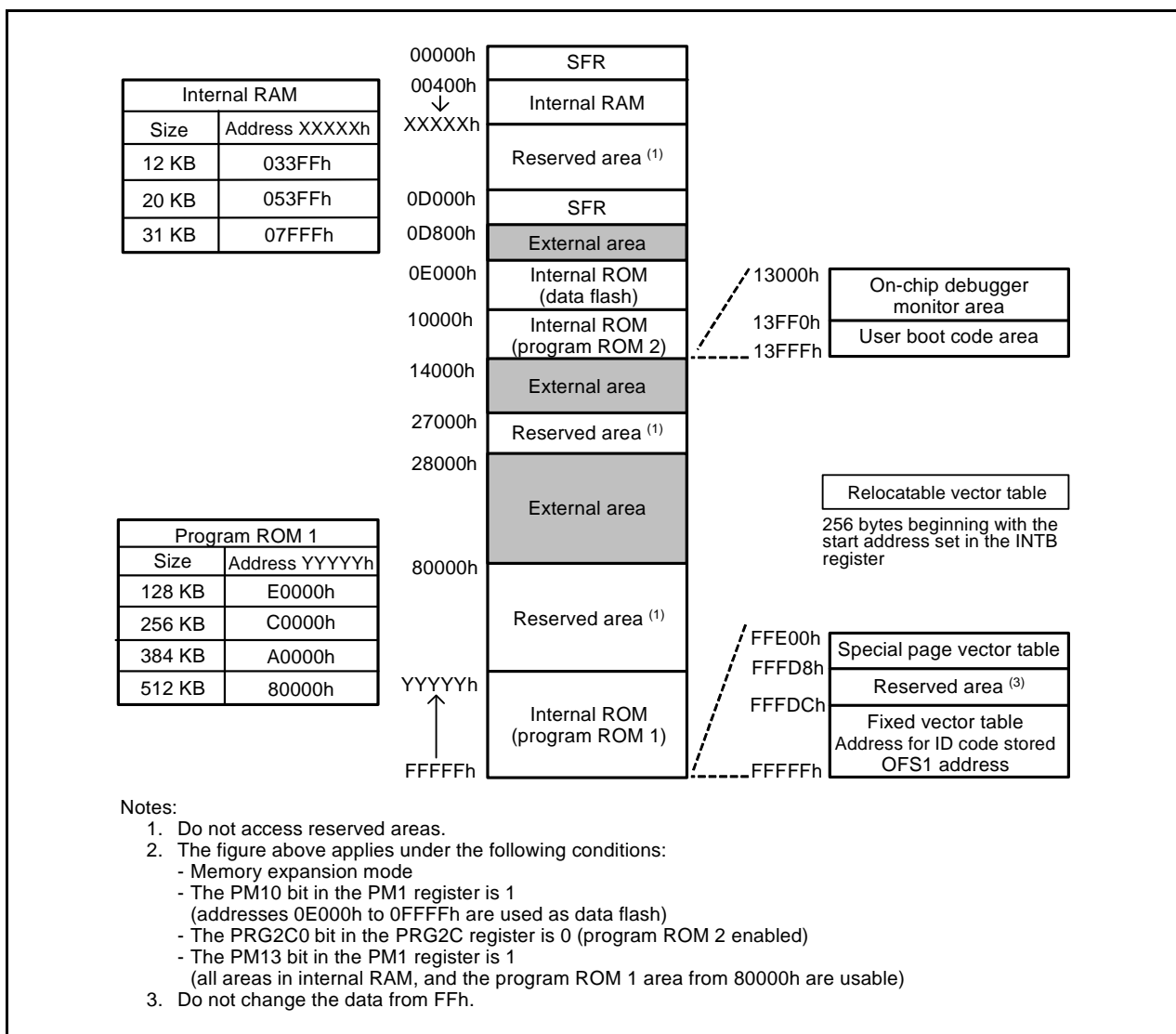

Figure 3.2 Memory Map

3.3 Accessible Area in Each Mode

Areas that can be accessed vary depending on processor mode and the status of each control bit. Figure 3.3 shows the Accessible Area in Each Mode.

In single-chip mode, the SFRs, internal RAM, and internal ROM can be accessed.

In memory expansion mode, the SFRs, internal RAM, internal ROM, and external areas can be accessed. Address space is expandable to 4 MB with the memory area expansion function.

In microprocessor mode, the SFRs, internal RAM, and external areas can be accessed. Address space is expandable to 4 MB with the memory area expansion function. Allocate ROM to the fixed vector table from FFFDCh to FFFFFh.

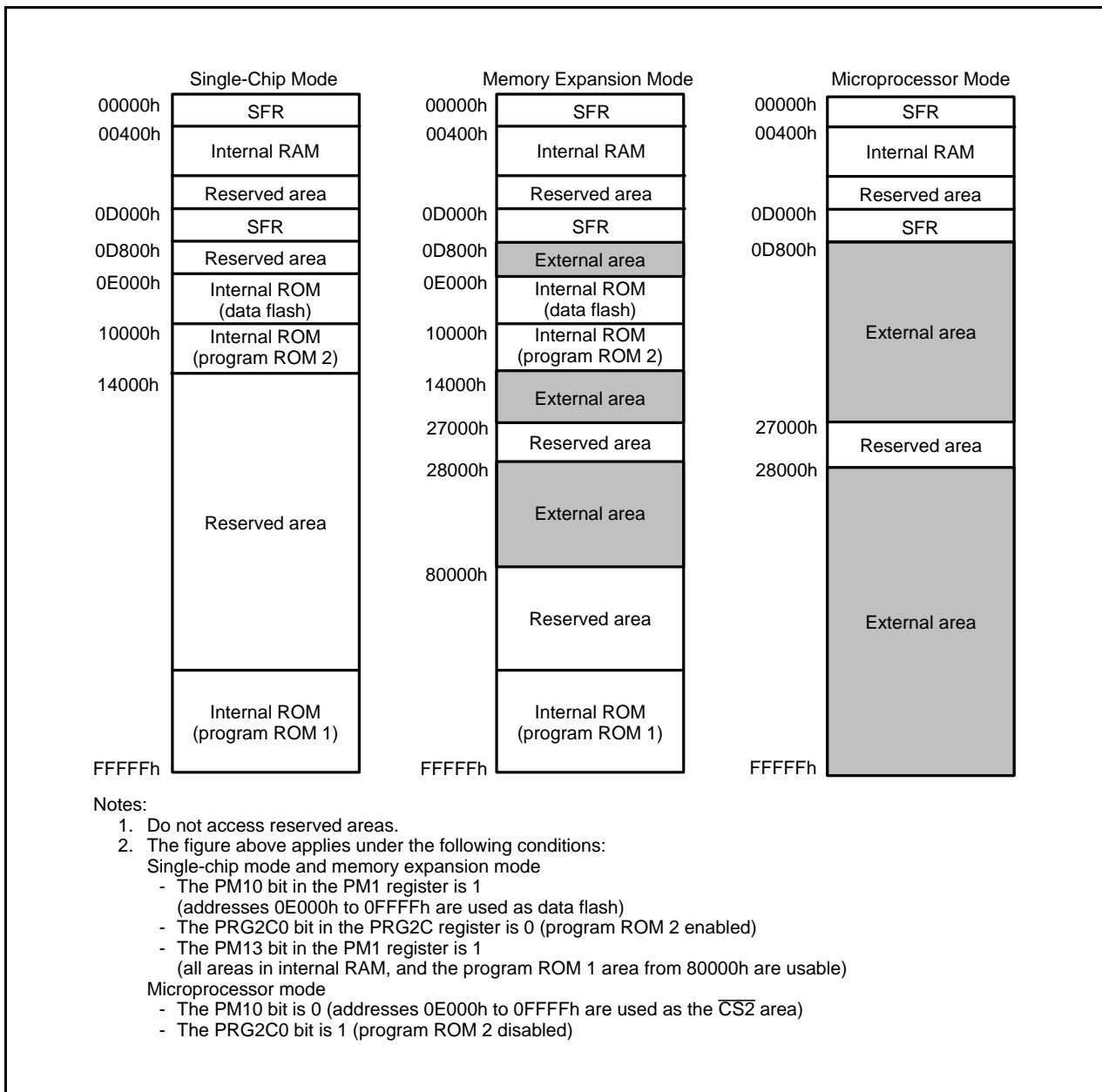

Figure 3.3 Accessible Area in Each Mode

4. Special Function Registers (SFRs)

4.1 SFRs

An SFR is a control register for a peripheral function.

Table 4.1 SFR Information (1) (1)

Address	Register	Symbol	Reset Value
0000h			
0001h			
0002h			
0003h			
0004h	Processor Mode Register 0	PM0	0000 0000b (CNVSS pin is low) 0000 0011b (CNVSS pin is high) ⁽²⁾
0005h	Processor Mode Register 1	PM1	0000 1000b
0006h	System Clock Control Register 0	CM0	0100 1000b
0007h	System Clock Control Register 1	CM1	0010 0000b
0008h	Chip Select Control Register	CSR	01h
0009h	External Area Recovery Cycle Control Register	EWR	XXXX XX00b
000Ah	Protect Register	PRCR	00h
000Bh	Data Bank Register	DBR	00h
000Ch	Oscillation Stop Detection Register	CM2	0X00 0010b ⁽³⁾
000Dh			
000Eh			
000Fh			
0010h	Program 2 Area Control Register	PRG2C	XXXX XX00b
0011h	External Area Wait Control Expansion Register	EWC	00h
0012h	Peripheral Clock Select Register	PCLKR	0000 0011b
0013h	Sub Clock Division Control Register	SCM0	XXXX X000b
0014h			
0015h	Clock Prescaler Reset Flag	CPSRF	0XXX XXXXb
0016h	Peripheral Clock Stop Register 1	PCLKSTP1	X000 0000b
0017h			
0018h	Reset Source Determine Register	RSTFR	XX00 001Xb (hardware reset) ⁽⁴⁾
0019h	Voltage Detector 2 Flag Register	VCR1	0000 1000b ⁽⁵⁾
001Ah	Voltage Detector Operation Enable Register	VCR2	00h ⁽⁵⁾
001Bh	Chip Select Expansion Control Register	CSE	00h
001Ch			
001Dh			
001Eh	Processor Mode Register 2	PM2	XX00 0X01b
001Fh			

X: Undefined

Notes:

1. The blank areas are reserved. No access is allowed.
2. Software reset, watchdog timer reset, oscillator stop detect reset, voltage monitor 1 reset, and voltage monitor 2 reset do not affect the following bits: bits PM01 and PM00 in the PM0 register.
3. Oscillator stop detect reset does not affect bits CM20, CM21, and CM27.
4. The state of bits in the RSTFR register depends on the reset type.
5. This is the reset value after hardware reset. Refer to the explanation of each register for details.

Table 4.2 SFR Information (2) ⁽¹⁾

Address	Register	Symbol	Reset Value
0020h			
0021h			
0022h	40 MHz On-Chip Oscillator Control Register 0	FRA0	XXXX XX00b
0023h			
0024h			
0025h			
0026h	Voltage Monitor Function Select Register	VWCE	00h
0027h			
0028h	Voltage Detector 1 Level Select Register	VD1LS	0000 1010b ⁽²⁾
0029h			
002Ah	Voltage Monitor 0 Control Register	VW0C	1000 XX10b ⁽²⁾
002Bh	Voltage Monitor 1 Control Register	VW1C	1000 1010b ⁽²⁾
002Ch	Voltage Monitor 2 Control Register	VW2C	1000 0X10b ⁽²⁾
002Dh			
002Eh			
002Fh			
0030h			
0031h			
0032h			
0033h			
0034h			
0035h			
0036h			
0037h			
0038h			
0039h			
003Ah			
003Bh			
003Ch			
003Dh			
003Eh			
003Fh			

X: Undefined

Notes:

1. The blank areas are reserved. No access is allowed.
2. This is the reset value after hardware reset. Refer to the explanation of each register for details.

Table 4.3 SFR Information (3) ⁽¹⁾

Address	Register	Symbol	Reset Value
0040h			
0041h			
0042h	INT7 Interrupt Control Register	INT7IC	XX00 X000b
0043h	INT6 Interrupt Control Register	INT6IC	XX00 X000b
0044h	INT3 Interrupt Control Register	INT3IC	XX00 X000b
0045h	Timer B5 Interrupt Control Register	TB5IC	XXXX X000b
0046h	Timer B4 Interrupt Control Register UART1 Bus Collision Detection Interrupt Control Register	TB4IC U1BCNIC	XXXX X000b
0047h	Timer B3 Interrupt Control Register UART0 Bus Collision Detection Interrupt Control Register	TB3IC U0BCNIC	XXXX X000b
0048h	SI/O4 Interrupt Control Register INT5 Interrupt Control Register	S4IC INT5IC	XX00 X000b
0049h	SI/O3 Interrupt Control Register INT4 Interrupt Control Register	S3IC INT4IC	XX00 X000b
004Ah	UART2 Bus Collision Detection Interrupt Control Register	BCNIC	XXXX X000b
004Bh	DMA0 Interrupt Control Register	DM0IC	XXXX X000b
004Ch	DMA1 Interrupt Control Register	DM1IC	XXXX X000b
004Dh	Key Input Interrupt Control Register	KUPIC	XX00 X000b
004Eh	A/D Conversion Interrupt Control Register	ADIC	XXXX X000b
004Fh	UART2 Transmit Interrupt Control Register	S2TIC	XXXX X000b
0050h	UART2 Receive Interrupt Control Register	S2RIC	XXXX X000b
0051h	UART0 Transmit Interrupt Control Register	S0TIC	XXXX X000b
0052h	UART0 Receive Interrupt Control Register	S0RIC	XXXX X000b
0053h	UART1 Transmit Interrupt Control Register	S1TIC	XXXX X000b
0054h	UART1 Receive Interrupt Control Register	S1RIC	XXXX X000b
0055h	Timer A0 Interrupt Control Register	TA0IC	XXXX X000b
0056h	Timer A1 Interrupt Control Register	TA1IC	XXXX X000b
0057h	Timer A2 Interrupt Control Register	TA2IC	XXXX X000b
0058h	Timer A3 Interrupt Control Register	TA3IC	XXXX X000b
0059h	Timer A4 Interrupt Control Register	TA4IC	XXXX X000b
005Ah	Timer B0 Interrupt Control Register	TB0IC	XXXX X000b
005Bh	Timer B1 Interrupt Control Register	TB1IC	XXXX X000b
005Ch	Timer B2 Interrupt Control Register	TB2IC	XXXX X000b
005Dh	INT0 Interrupt Control Register	INT0IC	XX00 X000b
005Eh	INT1 Interrupt Control Register	INT1IC	XX00 X000b
005Fh	INT2 Interrupt Control Register	INT2IC	XX00 X000b

X: Undefined

Note:

1. The blank areas are reserved. No access is allowed.

Table 4.4 SFR Information (4) ⁽¹⁾

Address	Register	Symbol	Reset Value
0060h			
0061h			
0062h			
0063h			
0064h			
0065h			
0066h			
0067h			
0068h			
0069h	DMA2 Interrupt Control Register	DM2IC	XXXX X000b
006Ah	DMA3 Interrupt Control Register	DM3IC	XXXX X000b
006Bh	UART5 Bus Collision Detection Interrupt Control Register CEC1 Interrupt Control Register	U5BCNIC CEC1IC	XXXX X000b
006Ch	UART5 Transmit Interrupt Control Register CEC2 Interrupt Control Register	S5TIC CEC2IC	XXXX X000b
006Dh	UART5 Receive Interrupt Control Register	S5RIC	XXXX X000b
006Eh	UART6 Bus Collision Detection Interrupt Control Register Real-Time Clock Periodic Interrupt Control Register	U6BCNIC RTCTIC	XXXX X000b
006Fh	UART6 Transmit Interrupt Control Register Real-Time Clock Alarm Interrupt Control Register	S6TIC RTCCIC	XXXX X000b
0070h	UART6 Receive Interrupt Control Register	S6RIC	XXXX X000b
0071h	UART7 Bus Collision Detection Interrupt Control Register Remote Control Signal Receiver 0 Interrupt Control Register	U7BCNIC PMC0IC	XXXX X000b
0072h	UART7 Transmit Interrupt Control Register Remote Control Signal Receiver 1 Interrupt Control Register	S7TIC PMC1IC	XXXX X000b
0073h	UART7 Receive Interrupt Control Register	S7RIC	XXXX X000b
0074h			
0075h			
0076h			
0077h			
0078h			
0079h			
007Ah			
007Bh	I2C-bus Interface Interrupt Control Register	IICIC	XXXX X000b
007Ch	SCL/SDA Interrupt Control Register	SCLDAIC	XXXX X000b
007Dh			
007Eh			
007Fh			
0080h to 017Fh			

X: Undefined

Note:

1. The blank areas are reserved. No access is allowed.

Table 4.5 SFR Information (5) ⁽¹⁾

Address	Register	Symbol	Reset Value
0180h	DMA0 Source Pointer	SAR0	XXh
0181h			XXh
0182h			0Xh
0183h			
0184h	DMA0 Destination Pointer	DAR0	XXh
0185h			XXh
0186h			0Xh
0187h			
0188h	DMA0 Transfer Counter	TCR0	XXh
0189h			XXh
018Ah			
018Bh			
018Ch	DMA0 Control Register	DM0CON	0000 0X00b
018Dh			
018Eh			
018Fh			
0190h	DMA1 Source Pointer	SAR1	XXh
0191h			XXh
0192h			0Xh
0193h			
0194h	DMA1 Destination Pointer	DAR1	XXh
0195h			XXh
0196h			0Xh
0197h			
0198h	DMA1 Transfer Counter	TCR1	XXh
0199h			XXh
019Ah			
019Bh			
019Ch	DMA1 Control Register	DM1CON	0000 0X00b
019Dh			
019Eh			
019Fh			
01A0h	DMA2 Source Pointer	SAR2	XXh
01A1h			XXh
01A2h			0Xh
01A3h			
01A4h	DMA2 Destination Pointer	DAR2	XXh
01A5h			XXh
01A6h			0Xh
01A7h			
01A8h	DMA2 Transfer Counter	TCR2	XXh
01A9h			XXh
01AAh			
01ABh			
01ACh	DMA2 Control Register	DM2CON	0000 0X00b
01ADh			
01AEh			
01AFh			

X: Undefined

Note:

1. The blank areas are reserved. No access is allowed.

Table 4.6 SFR Information (6) ⁽¹⁾

Address	Register	Symbol	Reset Value
01B0h	DMA3 Source Pointer	SAR3	XXh
01B1h			XXh
01B2h			0Xh
01B3h			
01B4h	DMA3 Destination Pointer	DAR3	XXh
01B5h			XXh
01B6h			0Xh
01B7h			
01B8h	DMA3 Transfer Counter	TCR3	XXh
01B9h			XXh
01BAh			
01BBh			
01BCh	DMA3 Control Register	DM3CON	0000 0X00b
01BDh			
01BEh			
01BFh			
01C0h	Timer B0-1 Register	TB01	XXh
01C1h			XXh
01C2h	Timer B1-1 Register	TB11	XXh
01C3h			XXh
01C4h	Timer B2-1 Register	TB21	XXh
01C5h			XXh
01C6h	Pulse Period/Pulse Width Measurement Mode Function Select Register 1	PPWFS1	XXXX X000b
01C7h			
01C8h	Timer B Count Source Select Register 0	TBCS0	00h
01C9h	Timer B Count Source Select Register 1	TBCS1	X0h
01CAh			
01CBh	Timer AB Division Control Register 0	TCKDIVC0	0000 X000b
01CCh			
01CDh			
01CEh			
01CFh			
01D0h	Timer A Count Source Select Register 0	TACS0	00h
01D1h	Timer A Count Source Select Register 1	TACS1	00h
01D2h	Timer A Count Source Select Register 2	TACS2	X0h
01D3h			
01D4h	16-bit Pulse Width Modulation Mode Function Select Register	PWMFS	0XX0 X00Xb
01D5h	Timer A Waveform Output Function Select Register	TAPOFS	XXX0 0000b
01D6h			
01D7h			
01D8h	Timer A Output Waveform Change Enable Register	TAOW	XXX0 X00Xb
01D9h			
01DAh	Three-Phase Protect Control Register	TPRC	00h
01DBh			
01DCh			
01DDh			
01DEh			
01DFh			

X: Undefined

Note:

1. The blank areas are reserved. No access is allowed.

Table 4.7 SFR Information (7) ⁽¹⁾

Address	Register	Symbol	Reset Value
01E0h	Timer B3-1 Register	TB31	XXh
01E1h			XXh
01E2h	Timer B4-1 Register	TB41	XXh
01E3h			XXh
01E4h	Timer B5-1 Register	TB51	XXh
01E5h			XXh
01E6h	Pulse Period/Pulse Width Measurement Mode Function Select Register 2	PPWFS2	XXXX X000b
01E7h			
01E8h	Timer B Count Source Select Register 2	TBCS2	00h
01E9h	Timer B Count Source Select Register 3	TBCS3	X0h
01EAh			
01EBh			
01ECh			
01EDh			
01EEh			
01EFh			
01F0h	PMC0 Function Select Register 0	PMC0CON0	00h
01F1h	PMC0 Function Select Register 1	PMC0CON1	00XX 0000b
01F2h	PMC0 Function Select Register 2	PMC0CON2	0000 00X0b
01F3h	PMC0 Function Select Register 3	PMC0CON3	00h
01F4h	PMC0 Status Register	PMC0STS	00h
01F5h	PMC0 Interrupt Source Select Register	PMC0INT	00h
01F6h	PMC0 Compare Control Register	PMC0CPC	XXX0 X000b
01F7h	PMC0 Compare Data Register	PMC0CPD	00h
01F8h	PMC1 Function Select Register 0	PMC1CON0	XXX0 X000b
01F9h	PMC1 Function Select Register 1	PMC1CON1	XXXX 0X00b
01FAh	PMC1 Function Select Register 2	PMC1CON2	0000 00X0b
01FBh	PMC1 Function Select Register 3	PMC1CON3	00h
01FCh	PMC1 Status Register	PMC1STS	X000 X00Xb
01FDh	PMC1 Interrupt Source Select Register	PMC1INT	X000 X00Xb
01FEh			
01FFh			
0200h			
0201h			
0202h			
0203h			
0204h			
0205h	Interrupt Source Select Register 3	IFSR3A	00h
0206h	Interrupt Source Select Register 2	IFSR2A	00h
0207h	Interrupt Source Select Register	IFSR	00h
0208h			
0209h			
020Ah			
020Bh			
020Ch			
020Dh			
020Eh	Address Match Interrupt Enable Register	AIER	XXXX XX00b
020Fh	Address Match Interrupt Enable Register 2	AIER2	XXXX XX00b

X: Undefined

Note:

1. The blank areas are reserved. No access is allowed.

Table 4.8 SFR Information (8) ⁽¹⁾

Address	Register	Symbol	Reset Value
0210h	Address Match Interrupt Register 0	RMAD0	00h
0211h			00h
0212h			X0h
0213h			
0214h	Address Match Interrupt Register 1	RMAD1	00h
0215h			00h
0216h			X0h
0217h			
0218h	Address Match Interrupt Register 2	RMAD2	00h
0219h			00h
021Ah			X0h
021Bh			
021Ch	Address Match Interrupt Register 3	RMAD3	00h
021Dh			00h
021Eh			X0h
021Fh			
0220h	Flash Memory Control Register 0	FMR0	0000 0001b (Other than user boot mode) 0010 0001b (User boot mode)
0221h	Flash Memory Control Register 1	FMR1	00X0 XX0Xb
0222h	Flash Memory Control Register 2	FMR2	XXXX 0000b
0223h	Flash Memory Control Register 3	FMR3	XXXX 0000b
0224h			
0225h			
0226h			
0227h			
0228h			
0229h			
022Ah			
022Bh			
022Ch			
022Dh			
022Eh			
022Fh			
0230h	Flash Memory Control Register 6	FMR6	XX0X XX00b
0231h			
0232h			
0233h			
0234h			
0235h			
0236h			
0237h			
0238h			
0239h			
023Ah			
023Bh			
023Ch			
023Dh			
023Eh			
023Fh			

X: Undefined

Note:

1. The blank areas are reserved. No access is allowed.

Table 4.9 SFR Information (9) ⁽¹⁾

Address	Register	Symbol	Reset Value
0240h			
0241h			
0242h			
0243h			
0244h	UART0 Special Mode Register 4	U0SMR4	00h
0245h	UART0 Special Mode Register 3	U0SMR3	000X 0X0Xb
0246h	UART0 Special Mode Register 2	U0SMR2	X000 0000b
0247h	UART0 Special Mode Register	U0SMR	X000 0000b
0248h	UART0 Transmit/Receive Mode Register	U0MR	00h
0249h	UART0 Bit Rate Register	U0BRG	XXh
024Ah	UART0 Transmit Buffer Register	U0TB	XXh
024Bh			XXh
024Ch	UART0 Transmit/Receive Control Register 0	U0C0	0000 1000b
024Dh	UART0 Transmit/Receive Control Register 1	U0C1	00XX 0010b
024Eh	UART0 Receive Buffer Register	U0RB	XXh
024Fh			XXh
0250h	UART Transmit/Receive Control Register 2	U0CON	X000 0000b
0251h			
0252h	UART Clock Select Register	UCLKSELO	X0h
0253h			
0254h	UART1 Special Mode Register 4	U1SMR4	00h
0255h	UART1 Special Mode Register 3	U1SMR3	000X 0X0Xb
0256h	UART1 Special Mode Register 2	U1SMR2	X000 0000b
0257h	UART1 Special Mode Register	U1SMR	X000 0000b
0258h	UART1 Transmit/Receive Mode Register	U1MR	00h
0259h	UART1 Bit Rate Register	U1BRG	XXh
025Ah	UART1 Transmit Buffer Register	U1TB	XXh
025Bh			XXh
025Ch	UART1 Transmit/Receive Control Register 0	U1C0	0000 1000b
025Dh	UART1 Transmit/Receive Control Register 1	U1C1	00XX 0010b
025Eh	UART1 Receive Buffer Register	U1RB	XXh
025Fh			XXh
0260h			
0261h			
0262h			
0263h			
0264h	UART2 Special Mode Register 4	U2SMR4	00h
0265h	UART2 Special Mode Register 3	U2SMR3	000X 0X0Xb
0266h	UART2 Special Mode Register 2	U2SMR2	X000 0000b
0267h	UART2 Special Mode Register	U2SMR	X000 0000b
0268h	UART2 Transmit/Receive Mode Register	U2MR	00h
0269h	UART2 Bit Rate Register	U2BRG	XXh
026Ah	UART2 Transmit Buffer Register	U2TB	XXh
026Bh			XXh
026Ch	UART2 Transmit/Receive Control Register 0	U2C0	0000 1000b
026Dh	UART2 Transmit/Receive Control Register 1	U2C1	0000 0010b
026Eh	UART2 Receive Buffer Register	U2RB	XXh
026Fh			XXh

X: Undefined

Note:

1. The blank areas are reserved. No access is allowed.

Table 4.10 SFR Information (10) ⁽¹⁾

Address	Register	Symbol	Reset Value
0270h	SI/O3 Transmit/Receive Register	S3TRR	XXh
0271h			
0272h	SI/O3 Control Register	S3C	0100 0000b
0273h	SI/O3 Bit Rate Register	S3BRG	XXh
0274h	SI/O4 Transmit/Receive Register	S4TRR	XXh
0275h			
0276h	SI/O4 Control Register	S4C	0100 0000b
0277h	SI/O4 Bit Rate Register	S4BRG	XXh
0278h	SI/O3, 4 Control Register 2	S34C2	00XX X0X0b
0279h			
027Ah			
027Bh			
027Ch			
027Dh			
027Eh			
027Fh			
0280h			
0281h			
0282h			
0283h			
0284h	UART5 Special Mode Register 4	U5SMR4	00h
0285h	UART5 Special Mode Register 3	U5SMR3	000X 0X0Xb
0286h	UART5 Special Mode Register 2	U5SMR2	X000 0000b
0287h	UART5 Special Mode Register	U5SMR	X000 0000b
0288h	UART5 Transmit/Receive Mode Register	U5MR	00h
0289h	UART5 Bit Rate Register	U5BRG	XXh
028Ah	UART5 Transmit Buffer Register	U5TB	XXh
028Bh			XXh
028Ch	UART5 Transmit/Receive Control Register 0	U5C0	0000 1000b
028Dh	UART5 Transmit/Receive Control Register 1	U5C1	0000 0010b
028Eh	UART5 Receive Buffer Register	U5RB	XXh
028Fh			XXh
0290h			
0291h			
0292h			
0293h			
0294h	UART6 Special Mode Register 4	U6SMR4	00h
0295h	UART6 Special Mode Register 3	U6SMR3	000X 0X0Xb
0296h	UART6 Special Mode Register 2	U6SMR2	X000 0000b
0297h	UART6 Special Mode Register	U6SMR	X000 0000b
0298h	UART6 Transmit/Receive Mode Register	U6MR	00h
0299h	UART6 Bit Rate Register	U6BRG	XXh
029Ah	UART6 Transmit Buffer Register	U6TB	XXh
029Bh			XXh
029Ch	UART6 Transmit/Receive Control Register 0	U6C0	0000 1000b
029Dh	UART6 Transmit/Receive Control Register 1	U6C1	0000 0010b
029Eh	UART6 Receive Buffer Register	U6RB	XXh
029Fh			XXh

X: Undefined

Note:

1. The blank areas are reserved. No access is allowed.

Table 4.11 SFR Information (11) ⁽¹⁾

Address	Register	Symbol	Reset Value
02A0h			
02A1h			
02A2h			
02A3h			
02A4h	UART7 Special Mode Register 4	U7SMR4	00h
02A5h	UART7 Special Mode Register 3	U7SMR3	000X 0X0Xb
02A6h	UART7 Special Mode Register 2	U7SMR2	X000 0000b
02A7h	UART7 Special Mode Register	U7SMR	X000 0000b
02A8h	UART7 Transmit/Receive Mode Register	U7MR	00h
02A9h	UART7 Bit Rate Register	U7BRG	XXh
02AAh	UART7 Transmit Buffer Register	U7TB	XXh
02ABh			XXh
02ACh	UART7 Transmit/Receive Control Register 0	U7C0	0000 1000b
02ADh	UART7 Transmit/Receive Control Register 1	U7C1	0000 0010b
02AEh	UART7 Receive Buffer Register	U7RB	XXh
02AFh			XXh
02B0h	I2C0 Data Shift Register	S00	XXh
02B1h			
02B2h	I2C0 Address Register 0	S0D0	0000 000Xb
02B3h	I2C0 Control Register 0	S1D0	00h
02B4h	I2C0 Clock Control Register	S20	00h
02B5h	I2C0 Start/Stop Condition Control Register	S2D0	0001 1010b
02B6h	I2C0 Control Register 1	S3D0	0011 0000b
02B7h	I2C0 Control Register 2	S4D0	00h
02B8h	I2C0 Status Register 0	S10	0001 000Xb
02B9h	I2C0 Status Register 1	S11	XXXX X000b
02BAh	I2C0 Address Register 1	S0D1	0000 000Xb
02BBh	I2C0 Address Register 2	S0D2	0000 000Xb
02BCh			
02BDh			
02BEh			
02BFh			
02C0h to 02FFh			

X: Undefined

Note:

1. The blank areas are reserved. No access is allowed.

Table 4.12 SFR Information (12) ⁽¹⁾

Address	Register	Symbol	Reset Value
0300h	Timer B3/B4/B5 Count Start Flag	TBSR	000X XXXXb
0301h			
0302h	Timer A1-1 Register	TA11	XXh
0303h			XXh
0304h	Timer A2-1 Register	TA21	XXh
0305h			XXh
0306h	Timer A4-1 Register	TA41	XXh
0307h			XXh
0308h	Three-Phase PWM Control Register 0	INVC0	00h
0309h	Three-Phase PWM Control Register 1	INVC1	00h
030Ah	Three-Phase Output Buffer Register 0	IDB0	XX11 1111b
030Bh	Three-Phase Output Buffer Register 1	IDB1	XX11 1111b
030Ch	Dead Time Timer	DTT	XXh
030Dh	Timer B2 Interrupt Generation Frequency Set Counter	ICTB2	XXh
030Eh	Position-Data-Retain Function Control Register	PDRF	XXXX 0000b
030Fh			
0310h	Timer B3 Register	TB3	XXh
0311h			XXh
0312h	Timer B4 Register	TB4	XXh
0313h			XXh
0314h	Timer B5 Register	TB5	XXh
0315h			XXh
0316h			
0317h			
0318h	Port Function Control Register	PFCR	0011 1111b
0319h			
031Ah			
031Bh	Timer B3 Mode Register	TB3MR	00XX 0000b
031Ch	Timer B4 Mode Register	TB4MR	00XX 0000b
031Dh	Timer B5 Mode Register	TB5MR	00XX 0000b
031Eh			
031Fh			
0320h	Count Start Flag	TABSR	00h
0321h			
0322h	One-Shot Start Flag	ONSF	00h
0323h	Trigger Select Register	TRGSR	00h
0324h	Increment/Decrement Flag	UDF	00h
0325h			
0326h	Timer A0 Register	TA0	XXh
0327h			XXh
0328h	Timer A1 Register	TA1	XXh
0329h			XXh
032Ah	Timer A2 Register	TA2	XXh
032Bh			XXh
032Ch	Timer A3 Register	TA3	XXh
032Dh			XXh
032Eh	Timer A4 Register	TA4	XXh
032Fh			XXh

X: Undefined

Note:

- The blank areas are reserved. No access is allowed.

Table 4.13 SFR Information (13) ⁽¹⁾

Address	Register	Symbol	Reset Value
0330h	Timer B0 Register	TB0	XXh
0331h			XXh
0332h	Timer B1 Register	TB1	XXh
0333h			XXh
0334h	Timer B2 Register	TB2	XXh
0335h			XXh
0336h	Timer A0 Mode Register	TA0MR	00h
0337h	Timer A1 Mode Register	TA1MR	00h
0338h	Timer A2 Mode Register	TA2MR	00h
0339h	Timer A3 Mode Register	TA3MR	00h
033Ah	Timer A4 Mode Register	TA4MR	00h
033Bh	Timer B0 Mode Register	TB0MR	00XX 0000b
033Ch	Timer B1 Mode Register	TB1MR	00XX 0000b
033Dh	Timer B2 Mode Register	TB2MR	00XX 0000b
033Eh	Timer B2 Special Mode Register	TB2SC	X000 0000b
033Fh			
0340h	Second Data Register	TRHSEC	0000 0000b
0341h	Minute Data Register	TRHMIN	0000 0000b
0342h	Hour Data Register	TRHHR	0000 0000b
0343h	Day-of-the-Week Data Register	TRHWK	0000 0000b
0344h	Date Data Register	TRHDY	0000 0001b
0345h	Month Data Register	TRHMON	0000 0001b
0346h	Year Data Register	TRHYR	0000 0000b
0347h	Timer RH Control Register	TRHCR	0000 0100b
0348h	Timer RH Count Source Select Register	TRHCSR	0000 1000b
0349h	Clock Error Correction Register	TRHADJ	0000 0000b
034Ah	Timer RH Interrupt Flag Register	TRHIFR	XXX0 0000b
034Bh	Timer RH Interrupt Enable Register	TRHIER	0000 0000b
034Ch	Alarm Minute Register	TRHAMN	0000 0000b
034Dh	Alarm Hour Register	TRHAHR	0000 0000b
034Eh	Alarm Day-of-the-Week Register	TRHAWK	0XXX X000b
034Fh	Timer RH Protect Register	TRHPRC	00XX XXXXb
0350h	CEC Function Control Register 1	CECC1	XXXX X000b
0351h	CEC Function Control Register 2	CECC2	00h
0352h	CEC Function Control Register 3	CECC3	XXXX 0000b
0353h	CEC Function Control Register 4	CECC4	00h
0354h	CEC Flag Register	CECFLG	00h
0355h	CEC Interrupt Source Select Register	CISEL	00h
0356h	CEC Transmit Buffer Register 1	CCTB1	00h
0357h	CEC Transmit Buffer Register 2	CCTB2	XXXX XX00b
0358h	CEC Receive Buffer Register 1	CCRB1	00h
0359h	CEC Receive Buffer Register 2	CCRB2	XXXX X000b
035Ah	CEC Receive Follower Address Set Register 1	CRADRI1	00h
035Bh	CEC Receive Follower Address Set Register 2	CRADRI2	00h
035Ch			
035Dh			
035Eh			
035Fh			

X: Undefined

Note:

1. The blank areas are reserved. No access is allowed.

Table 4.14 SFR Information (14) ⁽¹⁾

Address	Register	Symbol	Reset Value
0360h	Pull-Up Control Register 0	PUR0	00h
0361h	Pull-Up Control Register 1	PUR1	0000 0000b ⁽²⁾ 0000 0010b
0362h	Pull-Up Control Register 2	PUR2	00h
0363h			
0364h			
0365h			
0366h	Port Control Register	PCR	0000 0XX0b
0367h			
0368h			
0369h	NMI/SD Digital Filter Register	NMIDF	XXXX X000b
036Ah			
036Bh			
036Ch			
036Dh			
036Eh			
036Fh			
0370h	PWM Control Register 0	PWMCON0	00h
0371h			
0372h	PWM0 Prescaler	PWMPRE0	00h
0373h	PWM0 Register	PWMREG0	00h
0374h	PWM1 Prescaler	PWMPRE1	00h
0375h	PWM1 Register	PWMREG1	00h
0376h	PWM Control Register 1	PWMCON1	00h
0377h			
0378h			
0379h			
037Ah			
037Bh			
037Ch	Count Source Protection Mode Register	CSPR	00h ⁽³⁾
037Dh	Watchdog Timer Refresh Register	WDTR	XXh
037Eh	Watchdog Timer Start Register	WDTS	XXh
037Fh	Watchdog Timer Control Register	WDC	00XX XXXXb
0380h to 038Fh			

X: Undefined

Notes:

- The blank areas are reserved. No access is allowed.
- Values after hardware reset, power-on reset, or voltage monitor 0 reset are as follows:
 - 00000000b when a low-level signal is input to the CNVSS pin
 - 00000010b when a high-level signal is input to the CNVSS pin
 Values after voltage monitor 1 reset, voltage monitor 2 reset, software reset, watchdog timer reset, or oscillation stop detect reset are as follows:
 - 00000000b when bits PM01 and PM00 in the PM0 register are 00b (single-chip mode).
 - 00000010b when bits PM01 and PM00 in the PM0 register are 01b (memory expansion mode) or 11b (microprocessor mode).
- When the CSPROINI bit in the OFS1 address is 0, the reset value is 1000 0000b.

Table 4.15 SFR Information (15) ⁽¹⁾

Address	Register	Symbol	Reset Value
0390h	DMA2 Source Select Register	DM2SL	00h
0391h			
0392h	DMA3 Source Select Register	DM3SL	00h
0393h			
0394h			
0395h			
0396h			
0397h			
0398h	DMA0 Source Select Register	DM0SL	00h
0399h			
039Ah	DMA1 Source Select Register	DM1SL	00h
039Bh			
039Ch			
039Dh			
039Eh			
039Fh			
03A0h			
03A1h			
03A2h	Open-Circuit Detection Assist Function Register	AINRST	XX00 XXXXb
03A3h			
03A4h			
03A5h			
03A6h			
03A7h			
03A8h			
03A9h			
03AAh			
03ABh			
03ACh			
03ADh			
03AEh			
03AFh			
03B0h			
03B1h			
03B2h			
03B3h			
03B4h	SFR Snoop Address Register	CRCSAR	XXXX XXXXb
03B5h			00XX XXXXb
03B6h	CRC Mode Register	CRCMR	0XXX XXX0b
03B7h			
03B8h			
03B9h			
03BAh			
03BBh			
03BCh	CRC Data Register	CRCD	XXh
03BDh			XXh
03BEh	CRC Input Register	CRCIN	XXh
03BFh			

X: Undefined

Note:

1. The blank areas are reserved. No access is allowed.

Table 4.16 SFR Information (16) ⁽¹⁾

Address	Register	Symbol	Reset Value
03C0h	A/D Register 0	AD0	XXXX XXXXb
03C1h			0000 00XXb
03C2h	A/D Register 1	AD1	XXXX XXXXb
03C3h			0000 00XXb
03C4h	A/D Register 2	AD2	XXXX XXXXb
03C5h			0000 00XXb
03C6h	A/D Register 3	AD3	XXXX XXXXb
03C7h			0000 00XXb
03C8h	A/D Register 4	AD4	XXXX XXXXb
03C9h			0000 00XXb
03CAh	A/D Register 5	AD5	XXXX XXXXb
03CBh			0000 00XXb
03CCh	A/D Register 6	AD6	XXXX XXXXb
03CDh			0000 00XXb
03CEh	A/D Register 7	AD7	XXXX XXXXb
03CFh			0000 00XXb
03D0h			
03D1h			
03D2h			
03D3h			
03D4h	A/D Control Register 2	ADCON2	0000 X00Xb
03D5h			
03D6h	A/D Control Register 0	ADCON0	0000 0XXXb
03D7h	A/D Control Register 1	ADCON1	0000 0000b
03D8h	D/A0 Register	DA0	00h
03D9h			
03DAh	D/A1 Register	DA1	00h
03DBh			
03DCh	D/A Control Register	DACON	00h
03DDh			
03DEh			
03DFh			
03E0h	Port P0 Register	P0	XXh
03E1h	Port P1 Register	P1	XXh
03E2h	Port P0 Direction Register	PD0	00h
03E3h	Port P1 Direction Register	PD1	00h
03E4h	Port P2 Register	P2	XXh
03E5h	Port P3 Register	P3	XXh
03E6h	Port P2 Direction Register	PD2	00h
03E7h	Port P3 Direction Register	PD3	00h
03E8h	Port P4 Register	P4	XXh
03E9h	Port P5 Register	P5	XXh
03EAh	Port P4 Direction Register	PD4	00h
03EBh	Port P5 Direction Register	PD5	00h
03ECh	Port P6 Register	P6	XXh
03EDh	Port P7 Register	P7	XXh
03EEh	Port P6 Direction Register	PD6	00h
03EFh	Port P7 Direction Register	PD7	00h

X: Undefined

Note:

1. The blank areas are reserved. No access is allowed.

Table 4.17 SFR Information (17) ⁽¹⁾

Address	Register	Symbol	Reset Value
03F0h	Port P8 Register	P8	XXh
03F1h	Port P9 Register	P9	XXh
03F2h	Port P8 Direction Register	PD8	00h
03F3h	Port P9 Direction Register	PD9	00h
03F4h	Port P10 Register	P10	XXh
03F5h			
03F6h	Port P10 Direction Register	PD10	00h
03F7h			
03F8h			
03F9h			
03FAh			
03FBh			
03FCh			
03FDh			
03FEh			
03FFh			

X: Undefined

Note:

1. The blank areas are reserved. No access is allowed.

Table 4.18 SFR Information (18) ⁽¹⁾

Address	Register	Symbol	Reset Value
D080h	PMC0 Header Pattern Set Register (Min)	PMC0HDPMIN	0000 0000b
D081h			XXXX X000b
D082h	PMC0 Header Pattern Set Register (Max)	PMC0HDPMAX	0000 0000b
D083h			XXXX X000b
D084h	PMC0 Data 0 Pattern Set Register (Min)	PMC0D0PMIN	00h
D085h	PMC0 Data 0 Pattern Set Register (Max)	PMC0D0PMAX	00h
D086h	PMC0 Data 1 Pattern Set Register (Min)	PMC0D1PMIN	00h
D087h	PMC0 Data 1 Pattern Set Register (Max)	PMC0D1PMAX	00h
D088h	PMC0 Measurements Register	PMC0TIM	00h
D089h			00h
D08Ah			
D08Bh			
D08Ch	PMC0 Receive Data Store Register 0	PMC0DAT0	00h
D08Dh	PMC0 Receive Data Store Register 1	PMC0DAT1	00h
D08Eh	PMC0 Receive Data Store Register 2	PMC0DAT2	00h
D08Fh	PMC0 Receive Data Store Register 3	PMC0DAT3	00h
D090h	PMC0 Receive Data Store Register 4	PMC0DAT4	00h
D091h	PMC0 Receive Data Store Register 5	PMC0DAT5	00h
D092h	PMC0 Receive Bit Count Register	PMC0RBIT	XX00 0000b
D093h			
D094h	PMC1 Header Pattern Set Register (Min)	PMC1HDPMIN	0000 0000b
D095h			XXXX X000b
D096h	PMC1 Header Pattern Set Register (Max)	PMC1HDPMAX	0000 0000b
D097h			XXXX X000b
D098h	PMC1 Data 0 Pattern Set Register (Min)	PMC1D0PMIN	00h
D099h	PMC1 Data 0 Pattern Set Register (Max)	PMC1D0PMAX	00h
D09Ah	PMC1 Data 1 Pattern Set Register (Min)	PMC1D1PMIN	00h
D09Bh	PMC1 Data 1 Pattern Set Register (Max)	PMC1D1PMAX	00h
D09Ch	PMC1 Measurements Register	PMC1TIM	00h
D09Dh			00h
D09Eh			
D09Fh			

X: Undefined

Note:

1. The blank areas are reserved. No access is allowed.

4.2 Notes on SFRs

4.2.1 Register Settings

Table 4.19 lists Registers with Write-Only Bits and registers whose function differs between reading and writing. Set these registers with immediate values. Do not use read-modify-write instructions. When establishing the next value by altering the existing value, write the existing value to the RAM as well as to the register. Transfer the next value to the register after making changes in the RAM. Read-modify-write instructions can be used when writing to the no register bits.

Table 4.19 Registers with Write-Only Bits

Address	Register	Symbol
0249h	UART0 Bit Rate Register	U0BRG
024Bh to 024Ah	UART0 Transmit Buffer Register	U0TB
0259h	UART1 Bit Rate Register	U1BRG
025Bh to 025Ah	UART1 Transmit Buffer Register	U1TB
0269h	UART2 Bit Rate Register	U2BRG
026Bh to 026Ah	UART2 Transmit Buffer Register	U2TB
0273h	SI/O3 Bit Rate Register	S3BRG
0277h	SI/O4 Bit Rate Register	S4BRG
0289h	UART5 Bit Rate Register	U5BRG
028Bh to 028Ah	UART5 Transmit Buffer Register	U5TB
0299h	UART6 Bit Rate Register	U6BRG
029Bh to 029Ah	UART6 Transmit Buffer Register	U6TB
02A9h	UART7 Bit Rate Register	U7BRG
02ABh to 02AAh	UART7 Transmit Buffer Register	U7TB
02B6h	I2C0 Control Register 1	S3D0
02B8h	I2C0 Status Register 0	S10
0303h to 0302h	Timer A1-1 Register	TA11
0305h to 0304h	Timer A2-1 Register	TA21
0307h to 0306h	Timer A4-1 Register	TA41
030Ah	Three-Phase Output Buffer Register 0	IDB0
030Bh	Three-Phase Output Buffer Register 1	IDB1
030Ch	Dead Time Timer	DTT
030Dh	Timer B2 Interrupt Generation Frequency Set Counter	ICTB2
0327h to 0326h	Timer A0 Register	TA0
0329h to 0328h	Timer A1 Register	TA1
032Bh to 032Ah	Timer A2 Register	TA2
032Dh to 032Ch	Timer A3 Register	TA3
032Fh to 032Eh	Timer A4 Register	TA4
037Dh	Watchdog Timer Refresh Register	WDTR
037Eh	Watchdog Timer Start Register	WDTS

Table 4.20 Read-Modify-Write Instructions

Function	Mnemonic
Transfer	<i>MOVDir</i>
Bit processing	BCLR, <i>BMCnd</i> , BNOT, BSET, BTSTC, and BTSTS
Shifting	ROLC, RORC, ROT, SHA, and SHL
Arithmetic operation	ABS, ADC, ADCF, ADD, DEC, DIV, DIVU, DIVX, EXTS, INC, MUL, MULU, NEG, SBB, and SUB
Decimal operation	DADC, DADD, DSBB, and DSUB
Logical operation	AND, NOT, OR, and XOR
Jump	ADJNZ, SBJNZ

5. Electrical Characteristics

5.1 Electrical Characteristics (Common to 1.8 V, 3 V, and 5 V)

5.1.1 Absolute Maximum Rating

Table 5.1 Absolute Maximum Ratings

Symbol	Parameter		Condition	Rated Value	Unit
V_{CC1}	Supply voltage		$V_{CC1} = AV_{CC}$	-0.3 to 6.5	V
V_{CC2}	Supply voltage		$V_{CC1} = AV_{CC}$	-0.3 to $V_{CC1} + 0.1$ (1)	V
AV_{CC}	Analog supply voltage		$V_{CC1} = AV_{CC}$	-0.3 to 6.5	V
V_{REF}	Analog reference voltage		$V_{CC1} = AV_{CC}$	-0.3 to $V_{CC1} + 0.1$ (1)	V
V_I	Input voltage	RESET, CNVSS, BYTE, P6_0 to P6_7, P7_2 to P7_7, P8_0 to P8_4, P8_6, P8_7, P9_0 to P9_7, P10_0 to P10_7 XIN		-0.3 to $V_{CC1} + 0.3$ (1)	V
		P0_0 to P0_7, P1_0 to P1_7, P2_0 to P2_7, P3_0 to P3_7, P4_0 to P4_7, P5_0 to P5_7		-0.3 to $V_{CC2} + 0.3$ (1)	V
		P7_0, P7_1, P8_5		-0.3 to 6.5	V
V_O	Output voltage	P6_0 to P6_7, P7_2 to P7_7, P8_0 to P8_4, P8_6, P8_7, P9_0 to P9_7, P10_0 to P10_7 XOUT		-0.3 to $V_{CC1} + 0.3$ (1)	V
		P0_0 to P0_7, P1_0 to P1_7, P2_0 to P2_7, P3_0 to P3_7, P4_0 to P4_7, P5_0 to P5_7		-0.3 to $V_{CC2} + 0.3$ (1)	V
		P7_0, P7_1, P8_5		-0.3 to 6.5	V
P_d	Power consumption		$-40^\circ\text{C} < T_{opr} \leq 85^\circ\text{C}$	300	mW
T_{opr}	Operating temperature	When the MCU is operating		-20 to 85/-40 to 85	°C
		Flash program erase	Program area	-20 to 85/-40 to 85	
			Data area	-20 to 85/-40 to 85	
T_{stg}	Storage temperature			-65 to 150	°C

Note:

1. Maximum value is 6.5 V.

5.1.2 Recommended Operating Conditions

Table 5.2 Recommended Operating Conditions (1/4)

$V_{CC1} = V_{CC2} = 1.8$ to 5.5 V at $T_{opr} = -20^{\circ}\text{C}$ to $85^{\circ}\text{C}/-40^{\circ}\text{C}$ to 85°C unless otherwise specified.

Symbol	Parameter		Standard			Unit	
			Min.	Typ.	Max.		
V_{CC1}	Supply voltage	CEC function is not used ($V_{CC1} \geq V_{CC2}$)		2.7		5.5	V
		CEC function is not used ($V_{CC1} = V_{CC2}$)		1.8		5.5	V
		CEC function is used		2.7		3.63	V
V_{CC2}	Supply voltage	$V_{CC1} \geq 2.7$	2.7		V_{CC1}	V	
		$V_{CC1} < 2.7$		V_{CC1}		V	
AV_{CC}	Analog supply voltage			V_{CC1}		V	
V_{SS}	Supply voltage			0		V	
AV_{SS}	Analog supply voltage			0		V	
V_{IH}	High input voltage	P3_1 to P3_7, P4_0 to P4_7, P5_0 to P5_7	$2.7\text{ V} \leq V_{CC1} \leq 5.5\text{ V}$	$0.8V_{CC2}$		V_{CC2}	V
			$1.8\text{ V} \leq V_{CC1} < 2.7\text{ V}$	$0.85V_{CC2}$		V_{CC2}	V
		P0_0 to P0_7, P1_0 to P1_7, P2_0 to P2_7, P3_0 (in single-chip mode)	$2.7\text{ V} \leq V_{CC1} \leq 5.5\text{ V}$	$0.8V_{CC2}$		V_{CC2}	V
			$1.8\text{ V} \leq V_{CC1} < 2.7\text{ V}$	$0.85V_{CC2}$		V_{CC2}	V
		P0_0 to P0_7, P1_0 to P1_7, P2_0 to P2_7, P3_0 (data input in memory expansion and microprocessor modes)	$2.7\text{ V} \leq V_{CC1} \leq 5.5\text{ V}$	$0.5V_{CC2}$		V_{CC2}	V
			$1.8\text{ V} \leq V_{CC1} < 2.7\text{ V}$	$0.55V_{CC2}$		V_{CC2}	V
		P6_0 to P6_7, P7_2 to P7_7, P8_0 to P8_4, P8_6, P8_7, P9_0 to P9_7, P10_0 to P10_7, XIN, RESET, CNVSS, BYTE	$2.7\text{ V} \leq V_{CC1} \leq 5.5\text{ V}$	$0.8V_{CC1}$		V_{CC1}	V
			$1.8\text{ V} \leq V_{CC1} < 2.7\text{ V}$	$0.85V_{CC1}$		V_{CC1}	V
		P7_0, P7_1, P8_5	$2.7\text{ V} \leq V_{CC1} \leq 5.5\text{ V}$	$0.8V_{CC1}$		6.5	V
$1.8\text{ V} \leq V_{CC1} < 2.7\text{ V}$	$0.85V_{CC1}$			6.5	V		
CEC			$0.7V_{CC1}$			V	
V_{IL}	Low input voltage	P3_1 to P3_7, P4_0 to P4_7, P5_0 to P5_7		0		$0.2V_{CC2}$	V
		P0_0 to P0_7, P1_0 to P1_7, P2_0 to P2_7, P3_0 (in single-chip mode)		0		$0.2V_{CC2}$	V
		P0_0 to P0_7, P1_0 to P1_7, P2_0 to P2_7, P3_0 (data input in memory expansion and microprocessor mode)		0		$0.16V_{CC2}$	V
		P6_0 to P6_7, P7_0 to P7_7, P8_0 to P8_7, P9_0 to P9_7, P10_0 to P10_7, XIN, RESET, CNVSS, BYTE		0		$0.2V_{CC1}$	V
		CEC				$0.26V_{CC1}$	V

Table 5.3 Recommended Operating Conditions (2/4)
 $V_{CC1} = V_{CC2} = 1.8 \text{ to } 5.5 \text{ V}$ at $T_{opr} = -20^\circ\text{C}$ to $85^\circ\text{C}/-40^\circ\text{C}$ to 85°C unless otherwise specified.

Symbol	Parameter	Standard			Unit		
		Min.	Typ.	Max.			
$I_{OH(sum)}$	High peak output current (100-pin package)	$V_{CC1}, V_{CC2} \geq 2.7 \text{ V}$	Sum of $I_{OH(peak)}$ at P0_0 to P0_7, P1_0 to P1_7, P2_0 to P2_7			-40.0	mA
			Sum of $I_{OH(peak)}$ at P3_0 to P3_7, P4_0 to P4_7, P5_0 to P5_7			-40.0	mA
			Sum of $I_{OH(peak)}$ at P6_0 to P6_7, P7_2 to P7_7, P8_0 to P8_4			-40.0	mA
			Sum of $I_{OH(peak)}$ at P8_6, P8_7, P9_0 to P9_7, P10_0 to P10_7			-40.0	mA
	$V_{CC1}, V_{CC2} < 2.7 \text{ V}$	Sum of $I_{OH(peak)}$ at P0_0 to P0_7, P1_0 to P1_7, P2_0 to P2_7			-5.0	mA	
		Sum of $I_{OH(peak)}$ at P3_0 to P3_7, P4_0 to P4_7, P5_0 to P5_7			-5.0	mA	
		Sum of $I_{OH(peak)}$ at P6_0 to P6_7, P7_2 to P7_7, P8_0 to P8_4			-5.0	mA	
		Sum of $I_{OH(peak)}$ at P8_6, P8_7, P9_0 to P9_7, P10_0 to P10_7			-5.0	mA	
	High peak output current (80-pin package)	$V_{CC1}, V_{CC2} \geq 2.7 \text{ V}$	Sum of all ports			-80.0	mA
			$V_{CC1}, V_{CC2} < 2.7 \text{ V}$	Sum of all ports			-10.0
$I_{OH(peak)}$	High peak output current	$V_{CC1}, V_{CC2} \geq 2.7 \text{ V}$	P0_0 to P0_7, P1_0 to P1_7, P2_0 to P2_7, P3_0 to P3_7, P4_0 to P4_7, P5_0 to P5_7, P6_0 to P6_7, P7_2 to P7_7, P8_0 to P8_4, P8_6, P8_7, P9_0 to P9_7, P10_0 to P10_7			-10.0	mA
		$V_{CC1}, V_{CC2} < 2.7 \text{ V}$	P0_0 to P0_7, P1_0 to P1_7, P2_0 to P2_7, P3_0 to P3_7, P4_0 to P4_7, P5_0 to P5_7, P6_0 to P6_7, P7_2 to P7_7, P8_0 to P8_4, P8_6, P8_7, P9_0 to P9_7, P10_0 to P10_7			-1.0	mA
$I_{OH(avg)}$	High average output current (1)	$V_{CC1}, V_{CC2} \geq 2.7 \text{ V}$	P0_0 to P0_7, P1_0 to P1_7, P2_0 to P2_7, P3_0 to P3_7, P4_0 to P4_7, P5_0 to P5_7, P6_0 to P6_7, P7_2 to P7_7, P8_0 to P8_4, P8_6, P8_7, P9_0 to P9_7, P10_0 to P10_7			-5.0	mA
		$V_{CC1}, V_{CC2} < 2.7 \text{ V}$	P0_0 to P0_7, P1_0 to P1_7, P2_0 to P2_7, P3_0 to P3_7, P4_0 to P4_7, P5_0 to P5_7, P6_0 to P6_7, P7_2 to P7_7, P8_0 to P8_4, P8_6, P8_7, P9_0 to P9_7, P10_0 to P10_7			-0.5	mA

Note:

- The average output current is the mean value within 100 ms.

Table 5.4 Recommended Operating Conditions (3/4)
 $V_{CC1} = V_{CC2} = 1.8 \text{ to } 5.5 \text{ V}$ at $T_{opr} = -20^\circ\text{C}$ to $85^\circ\text{C}/-40^\circ\text{C}$ to 85°C unless otherwise specified.

Symbol	Parameter		Standard			Unit	
			Min.	Typ.	Max.		
$I_{OL(sum)}$	Low peak output current (100-pin package)	$V_{CC1}, V_{CC2} \geq 2.7 \text{ V}$	Sum of $I_{OL(peak)}$ at P0_0 to P0_7, P1_0 to P1_7, P2_0 to P2_7, P8_6, P8_7, P9_0 to P9_7, P10_0 to P10_7			80.0	mA
			Sum of $I_{OL(peak)}$ at P3_0 to P3_7, P4_0 to P4_7, P5_0 to P5_7, P6_0 to P6_7, P7_0 to P7_7, P8_0 to P8_5			80.0	mA
		$V_{CC1}, V_{CC2} < 2.7 \text{ V}$	Sum of $I_{OL(peak)}$ at P0_0 to P0_7, P1_0 to P1_7, P2_0 to P2_7, P8_6, P8_7, P9_0 to P9_7, P10_0 to P10_7			10.0	mA
			Sum of $I_{OL(peak)}$ at P3_0 to P3_7, P4_0 to P4_7, P5_0 to P5_7, P6_0 to P6_7, P7_0 to P7_7, P8_0 to P8_5			10.0	mA
	Low peak output current (80-pin package)	$V_{CC1}, V_{CC2} \geq 2.7 \text{ V}$	Sum of all ports			80.0	mA
			$V_{CC1}, V_{CC2} < 2.7 \text{ V}$	Sum of all ports			10.0
$I_{OL(peak)}$	Low peak output current	$V_{CC1}, V_{CC2} \geq 2.7 \text{ V}$	P0_0 to P0_7, P1_0 to P1_7, P2_0 to P2_7, P3_0 to P3_7, P4_0 to P4_7, P5_0 to P5_7, P6_0 to P6_7, P7_0 to P7_7, P8_0 to P8_7, P9_0 to P9_7, P10_0 to P10_7			10.0	mA
		$V_{CC1}, V_{CC2} < 2.7 \text{ V}$	P0_0 to P0_7, P1_0 to P1_7, P2_0 to P2_7, P3_0 to P3_7, P4_0 to P4_7, P5_0 to P5_7, P6_0 to P6_7, P7_0 to P7_7, P8_0 to P8_7, P9_0 to P9_7, P10_0 to P10_7			1.0	mA
$I_{OL(avg)}$	Low average output current (1)	$V_{CC1}, V_{CC2} \geq 2.7 \text{ V}$	P0_0 to P0_7, P1_0 to P1_7, P2_0 to P2_7, P3_0 to P3_7, P4_0 to P4_7, P5_0 to P5_7, P6_0 to P6_7, P7_0 to P7_7, P8_0 to P8_7, P9_0 to P9_7, P10_0 to P10_7			5.0	mA
		$V_{CC1}, V_{CC2} < 2.7 \text{ V}$	P0_0 to P0_7, P1_0 to P1_7, P2_0 to P2_7, P3_0 to P3_7, P4_0 to P4_7, P5_0 to P5_7, P6_0 to P6_7, P7_0 to P7_7, P8_0 to P8_7, P9_0 to P9_7, P10_0 to P10_7			0.5	mA
$f_{(XIN)}$	Main clock input oscillation frequency	$2.7 \text{ V} \leq V_{CC1} \leq 5.5 \text{ V}$		1		20	MHz
		$1.8 \text{ V} \leq V_{CC1} < 2.7 \text{ V}$		1		10	MHz
$f_{(XCIN)}$	Sub clock oscillation frequency				32.768		kHz
$f_{(BCLK)}$	CPU operation clock	$2.7 \text{ V} \leq V_{CC1} \leq 5.5 \text{ V}, 1 \text{ MHz} \leq f_{(XIN)} \leq 20 \text{ MHz}$				20	MHz
		$2.1 \text{ V} \leq V_{CC1} < 2.7 \text{ V}, 1 \text{ MHz} \leq f_{(XIN)} \leq 10 \text{ MHz}$				10	MHz
		$1.8 \text{ V} \leq V_{CC1} < 2.1 \text{ V}, 1 \text{ MHz} \leq f_{(XIN)} \leq 10 \text{ MHz}$				(Note 2)	MHz

Notes:

- The average output current is the mean value within 100 ms.
- Calculated by the following equation according to V_{CC1} : $16.67 \times V_{CC1} - 25$ [MHz]

See Figure 5.1 "Relation between $f_{(BCLK)}$ and V_{CC1} "

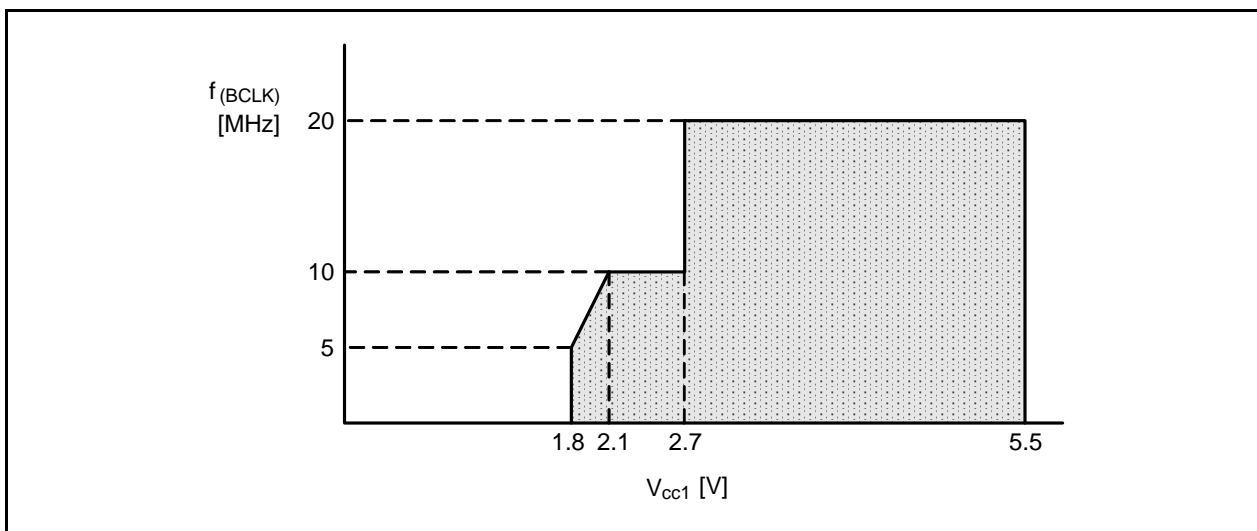

Figure 5.1 Relation between $f_{(BCLK)}$ and V_{CC1}

Table 5.5 Recommended Operating Conditions (4/4)⁽¹⁾

$V_{CC1} = 1.8$ to 5.5 V, $V_{SS} = 0$ V, and $T_{opr} = -20^{\circ}\text{C}$ to $85^{\circ}\text{C}/-40^{\circ}\text{C}$ to 85°C unless otherwise specified.
The ripple voltage must not exceed $V_{r(VCC1)}$ and/or $dV_{r(VCC1)}/dt$.

Symbol	Parameter	Standard			Unit	
		Min.	Typ.	Max.		
$V_{r(VCC1)}$	Allowable ripple voltage	$V_{CC1} = 5.0$ V			0.5	Vp-p
		$V_{CC1} = 3.0$ V			0.3	Vp-p
		$V_{CC1} = 2.0$ V			0.2	Vp-p
$dV_{r(VCC1)}/dt$	Ripple voltage falling gradient	$V_{CC1} = 5.0$ V			0.3	V/ms
		$V_{CC1} = 3.0$ V			0.3	V/ms
		$V_{CC1} = 2.0$ V			0.3	V/ms

Note:

- The device is operationally guaranteed under these operating conditions.

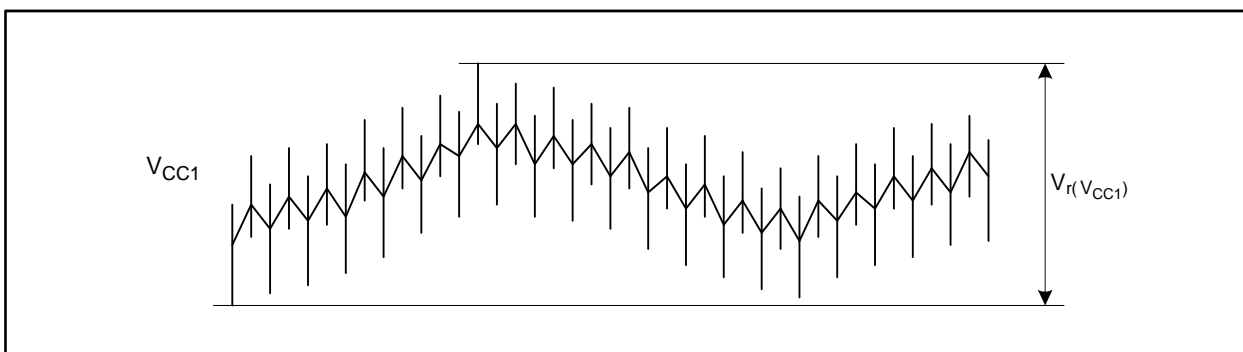

Figure 5.2 Ripple Waveform

5.1.3 A/D Conversion Characteristics

Table 5.6 A/D Conversion Characteristics (1/2) (1)

$AV_{CC} = V_{CC1} = V_{CC2} = V_{REF} = 1.8$ to 5.5 V, $V_{SS} = AV_{SS} = 0$ V at $T_{opr} = -20^{\circ}\text{C}$ to $85^{\circ}\text{C}/-40^{\circ}\text{C}$ to 85°C unless otherwise specified.

Symbol	Parameter		Measuring Condition	Standard			Unit	
				Min.	Typ.	Max.		
-	Resolution		$AV_{CC} = V_{CC1} = V_{CC2} = V_{REF}$			10	Bits	
I_{NL}	Integral non-linearity error	10 bits	$V_{CC1} = 5.0$ V	AN0 to AN7 input, AN0_0 to AN0_7 input, AN2_0 to AN2_7 input, ANEX0, ANEX1 input (Note 2)			± 3	LSB
			$V_{CC1} = 3.3$ V	AN0 to AN7 input, AN0_0 to AN0_7 input, AN2_0 to AN2_7 input, ANEX0, ANEX1 input (Note 2)			± 3	LSB
			$V_{CC1} = 3.0$ V	AN0 to AN7 input, AN0_0 to AN0_7 input, AN2_0 to AN2_7 input, ANEX0, ANEX1 input (Note 2)			± 3	LSB
			$V_{CC1} = 2.2$ V (3)	AN0 to AN7 input, AN0_0 to AN0_7 input, AN2_0 to AN2_7 input (Note 2)			± 6	LSB
			$V_{CC1} = 1.8$ V (3)	AN0 to AN7 input, AN0_0 to AN0_7 input, AN2_0 to AN2_7 input (Note 2)			± 6	LSB
-	Absolute accuracy	10 bits	$V_{CC1} = 5.0$ V	AN0 to AN7 input, AN0_0 to AN0_7 input, AN2_0 to AN2_7 input, ANEX0, ANEX1 input (Note 2)			± 3	LSB
			$V_{CC1} = 3.3$ V	AN0 to AN7 input, AN0_0 to AN0_7 input, AN2_0 to AN2_7 input, ANEX0, ANEX1 input (Note 2)			± 3	LSB
			$V_{CC1} = 3.0$ V	AN0 to AN7 input, AN0_0 to AN0_7 input, AN2_0 to AN2_7 input, ANEX0, ANEX1 input (Note 2)			± 3	LSB
			$V_{CC1} = 2.2$ V (3)	AN0 to AN7 input, AN0_0 to AN0_7 input, AN2_0 to AN2_7 input (Note 2)			± 6	LSB
			$V_{CC1} = 1.8$ V (3)	AN0 to AN7 input, AN0_0 to AN0_7 input, AN2_0 to AN2_7 input (Note 2)			± 6	LSB

Notes:

1. Use when $AV_{CC} = V_{CC1} = V_{CC2}$.
2. Flash memory rewrite disabled. Except for the analog input pin, set the pins to be measured as input ports and connect them to V_{SS} . See Figure 5.3 "A/D Accuracy Measure Circuit".
3. PUMPON bit in the ADCON1 register is 1 (Voltage multiplier ON)

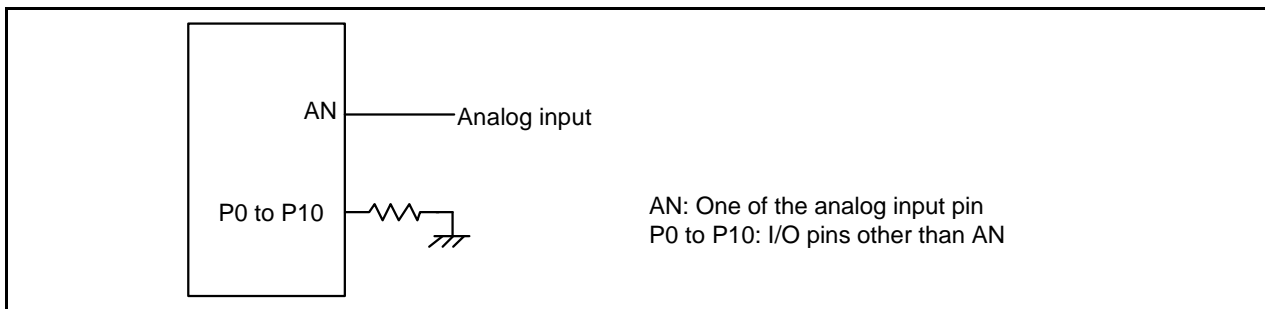

Figure 5.3 A/D Accuracy Measure Circuit

Table 5.7 A/D Conversion Characteristics (2/2) (1)

$AV_{CC} = V_{CC1} = V_{CC2} = V_{REF} = 1.8$ to 5.5 V, $V_{SS} = AV_{SS} = 0$ V at $T_{opr} = -20^{\circ}\text{C}$ to $85^{\circ}\text{C}/-40^{\circ}\text{C}$ to 85°C unless otherwise specified.

Symbol	Parameter	Measuring Condition	Standard			Unit
			Min.	Typ.	Max.	
ϕ_{AD}	A/D operating clock frequency	$4.0\text{ V} \leq V_{REF} \leq AV_{CC} \leq 5.5\text{ V}$	2		20	MHz
		$3.2\text{ V} \leq V_{REF} \leq AV_{CC} \leq 5.5\text{ V}$	2		16	MHz
		$3.0\text{ V} \leq V_{REF} \leq AV_{CC} \leq 5.5\text{ V}$	2		10	MHz
		$1.8\text{ V} \leq V_{REF} \leq AV_{CC} \leq 5.5\text{ V}$	2		5	MHz
-	Tolerance level impedance		3		$\text{k}\Omega$	
D_{NL}	Differential non-linearity error	(4)			± 1	LSB
-	Offset error	(4)			± 3	LSB
-	Gain error	(4)			± 3	LSB
t_{CONV}	10-bit conversion time	$V_{CC1} = 5\text{ V}$, $\phi_{AD} = 20\text{ MHz}$	2.15			μs
t_{SAMP}	Sampling time		0.75			μs
V_{REF}	Reference voltage		1.8		AV_{CC}	V
V_{IA}	Analog input voltage (2), (3)		0		V_{REF}	V

Notes:

1. Use when $AV_{CC} = V_{CC1} = V_{CC2}$.
2. Do not use A/D converter when $V_{CC1} > V_{CC2}$.
3. When analog input voltage is over reference voltage, the result of A/D conversion is 3FFh.
4. Flash memory rewrite disabled. Except for the analog input pin, set the pins to be measured as input ports and connect them to V_{SS} . See Figure 5.3 "A/D Accuracy Measure Circuit".

5.1.4 D/A Conversion Characteristics

Table 5.8 D/A Conversion Characteristics

$V_{CC1} = AV_{CC} = V_{REF} = 3.0$ to 5.5 V, $V_{SS} = AV_{SS} = 0$ V at $T_{opr} = -20^{\circ}\text{C}$ to $85^{\circ}\text{C}/-40^{\circ}\text{C}$ to 85°C unless otherwise specified.

Symbol	Parameter	Measuring Condition	Standard			Unit
			Min.	Typ.	Max.	
-	Resolution				8	Bits
-	Absolute Accuracy				2.5	LSB
t_{SU}	Setup Time				3	μs
R_O	Output Resistance		5	6	8.2	$\text{k}\Omega$
I_{VREF}	Reference Power Supply Input Current	See Notes 1 and 2			1.5	mA

Notes:

1. This applies when using one D/A converter, with the D/A register for the unused D/A converter set to 00h.
2. The current consumption of the A/D converter is not included. Also, the I_{VREF} of the D/A converter will flow even if the ADSTBY bit in the ADCON1 register is 0 (A/D operation stopped (standby)).

5.1.5 Flash Memory Electrical Characteristics

Table 5.9 CPU Clock When Operating Flash Memory ($f_{(BCLK)}$)

$V_{CC1} = 1.8$ to 5.5 V, $T_{opr} = -20^{\circ}\text{C}$ to $85^{\circ}\text{C}/-40^{\circ}\text{C}$ to 85°C unless otherwise specified.

Symbol	Parameter	Conditions	Standard			Unit
			Min.	Typ.	Max.	
-	CPU rewrite mode				10 (1)	MHz
$f(\text{SLOW_R})$	Slow read mode				5 (3)	MHz
-	Low current consumption read mode			$f_{C(32.768)}$	35	kHz
-	Data flash read	$3.0\text{ V} < V_{CC1} \leq 5.5\text{ V}$			20 (2)	MHz

Notes:

- Set the PM17 bit in the PM1 register to 1 (one wait).
- When the frequency is $1.8 \leq V_{CC1} \leq 3.0$ V, set the FMR17 bit in the FMR1 register to 0 (one wait) or the PM17 bit in the PM1 register to 1 (one wait)
- Set the PM17 bit in the PM1 register to 1 (one wait). When using 125 kHz on-chip oscillator clock or sub clock as the CPU clock source, a wait is not necessary.

Table 5.10 Flash Memory (Program ROM 1, 2) Electrical Characteristics

$V_{CC1} = 2.7$ to 5.5 V at $T_{opr} = 0^{\circ}\text{C}$ to 60°C (option: -40°C to 85°C), unless otherwise specified.

Symbol	Parameter	Conditions	Standard			Unit
			Min.	Typ.	Max.	
-	Program and erase cycles (1), (3), (4)	$V_{CC1} = 3.3\text{ V}$, $T_{opr} = 25^{\circ}\text{C}$	1,000 (2)			times
-	2 word program time	$V_{CC1} = 3.3\text{ V}$, $T_{opr} = 25^{\circ}\text{C}$		150	4000	μs
-	Lock bit program time	$V_{CC1} = 3.3\text{ V}$, $T_{opr} = 25^{\circ}\text{C}$		70	3000	μs
-	Block erase time	$V_{CC1} = 3.3\text{ V}$, $T_{opr} = 25^{\circ}\text{C}$		0.2	3.0	s
$t_{d(\text{SR-SUS})}$	Time delay from suspend request until suspend				$5 + \frac{3}{f_{(BCLK)}}$	ms
-	Interval from erase start/restart until following suspend request		0			μs
-	Suspend interval necessary for auto-erasure to complete (7)		20			ms
-	Time from suspend until erase restart				$30 + \frac{1}{f_{(BCLK)}}$	μs
-	Program, erase voltage		2.7		5.5	V
-	Read voltage	$T_{opr} = -20^{\circ}\text{C}$ to $85^{\circ}\text{C}/-40^{\circ}\text{C}$ to 85°C	2.7		5.5	V
-	Program, erase temperature		0		60	$^{\circ}\text{C}$
t_{PS}	Flash memory circuit stabilization wait time				50	μs
-	Data hold time (6)	Ambient temperature = 55°C	20			year

Notes:

- Definition of program and erase cycles:
The program and erase cycles refer to the number of per-block erasures. If the program and erase cycles are n ($n = 1,000$), each block can be erased n times. For example, if a block is erased after writing 2 word data 16,384 times, each to a different address, this counts as one program and erase cycles. Data cannot be written to the same address more than once without erasing the block (rewrite prohibited).
- Cycles to guarantee all electrical characteristics after program and erase. (1 to Min. value can be guaranteed).
- In a system that executes multiple programming operations, the actual erasure count can be reduced by writing to sequential addresses in turn so that as much of the block as possible is used up before performing an erase operation. It is advisable to retain data on the erasure cycles of each block and limit the number of erase operations to a certain number.
- If an error occurs during block erase, attempt to execute the clear status register command, then execute the block erase command at least three times until the erase error does not occur.
- Customers desiring program/erase failure rate information should contact a Renesas Electronics sales office.
- The data hold time includes time that the power supply is off or the clock is not supplied.
- After an erase start or erase restart, if an interval of at least 20 ms is not set before the next suspend request, the erase sequence cannot be completed.

Table 5.11 Flash Memory (Data Flash) Electrical Characteristics

$V_{CC1} = 2.7$ to 5.5 V at $T_{opr} = -20$ to $85^{\circ}\text{C}/-40$ to 85°C , unless otherwise specified.

Symbol	Parameter	Conditions	Standard			Unit
			Min.	Typ.	Max.	
-	Program and erase cycles (1), (3), (4)	$V_{CC1} = 3.3$ V, $T_{opr} = 25^{\circ}\text{C}$	10,000 (2)			times
-	2 word program time	$V_{CC1} = 3.3$ V, $T_{opr} = 25^{\circ}\text{C}$		300	4000	μs
-	Lock bit program time	$V_{CC1} = 3.3$ V, $T_{opr} = 25^{\circ}\text{C}$		140	3000	μs
-	Block erase time	$V_{CC1} = 3.3$ V, $T_{opr} = 25^{\circ}\text{C}$		0.2	3.0	s
$t_{d(SR-SUS)}$	Time delay from suspend request until suspend				$5 + \frac{3}{f_{(BCLK)}}$	ms
-	Interval from erase start/restart until following suspend request		0			μs
-	Suspend interval necessary for auto-erasure to complete (7)		20			ms
-	Time from suspend until erase restart				$30 + \frac{1}{f_{(BCLK)}}$	μs
-	Program, erase voltage		2.7		5.5	V
-	Read voltage		2.7		5.5	V
-	Program, erase temperature		-20/-40		85	$^{\circ}\text{C}$
t_{PS}	Flash memory circuit stabilization wait time				50	μs
-	Data hold time (6)	Ambient temperature = 55°C	20			year

Notes:

- Definition of program and erase cycles
The program and erase cycles refer to the number of per-block erasures.
If the program and erase cycles are n ($n = 10,000$), each block can be erased n times.
For example, if a 4 KB block is erased after writing 2 word data 1,024 times, each to a different address, this counts as one program and erase cycles. Data cannot be written to the same address more than once without erasing the block (rewrite prohibited).
- Cycles to guarantee all electrical characteristics after program and erase. (1 to Min. value can be guaranteed).
- In a system that executes multiple programming operations, the actual erasure count can be reduced by writing to sequential addresses in turn so that as much of the block as possible is used up before performing an erase operation. For example, when programming groups of 16 bytes, the effective number of rewrites can be minimized by programming up to 256 groups before erasing them all in one operation. In addition, averaging the erasure cycles between blocks A and B can further reduce the actual erasure cycles. It is also advisable to retain data on the erasure cycles of each block and limit the number of erase operations to a certain number.
- If an error occurs during block erase, attempt to execute the clear status register command, then execute the block erase command at least three times until the erase error does not occur.
- Customers desiring program/erase failure rate information should contact a Renesas Electronics sales office.
- The data hold time includes time that the power supply is off or the clock is not supplied.
- After an erase start or erase restart, if an interval of at least 20 ms is not set before the next suspend request, the erase sequence cannot be completed.

5.1.6 Voltage Detector and Power Supply Circuit Electrical Characteristics

Table 5.12 Voltage Detector 0 Electrical Characteristics

The measurement condition is $V_{CC1} = 1.8$ to 5.5 V, $T_{opr} = -20^{\circ}\text{C}$ to $85^{\circ}\text{C}/-40^{\circ}\text{C}$ to 85°C , unless otherwise specified.

Symbol	Parameter	Condition	Standard			Unit
			Min.	Typ.	Max.	
V_{det0}	Voltage detection level V_{det0_0} (1)	When V_{CC1} is falling.	1.80	1.90	2.10	V
	Voltage detection level V_{det0_2} (1)	When V_{CC1} is falling.	2.70	2.85	3.00	V
-	Voltage detector 0 response time (3)	When V_{CC1} falls from 5 V to $(V_{det0_0} - 0.1)$ V			200	μs
-	Voltage detector self power consumption	$VC25 = 1$, $V_{CC1} = 5.0$ V		1.5		μA
$t_{d(E-A)}$	Waiting time until voltage detector operation starts (2)				100	μs

Notes:

1. Select the voltage detection level with the VDSEL1 bit in the OFS1 address.
2. Necessary time until the voltage detector operates when setting to 1 again after setting the VC25 bit in the VCR2 register to 0.
3. Time from when passing the V_{det0} until when a voltage monitor 0 reset is generated.

Table 5.13 Voltage Detector 1 Electrical Characteristics

The measurement condition is $V_{CC1} = 1.8$ to 5.5 V, $T_{opr} = -20^{\circ}\text{C}$ to $85^{\circ}\text{C}/-40^{\circ}\text{C}$ to 85°C , unless otherwise specified.

Symbol	Parameter	Condition	Standard			Unit
			Min.	Typ.	Max.	
V_{det1}	Voltage detection level V_{det1_0} (1)	When V_{CC1} is falling.	1.90	2.20	2.50	V
	Voltage detection level V_{det1_6} (1)	When V_{CC1} is falling.	2.80	3.10	3.40	V
	Voltage detection level V_{det1_B} (1)	When V_{CC1} is falling.	3.55	3.85	4.15	V
	Voltage detection level V_{det1_F} (1)	When V_{CC1} is falling.	4.15	4.45	4.75	V
-	Hysteresis width at the rising of V_{CC1} in voltage detector 1	When selecting V_{det1_0}		0.10		V
		When selecting V_{det1_6} to V_{det1_F}		0.15		V
-	Voltage detector 1 response time (3)	When V_{CC1} falls from 5 V to $(V_{det1_0} - 0.1)$ V			200	μs
-	Voltage detector self power consumption	$VC26 = 1$, $V_{CC1} = 5.0$ V		1.7		μA
$t_{d(E-A)}$	Waiting time until voltage detector operation starts (2)				100	μs

Notes:

1. Select the voltage detection level with bits VD1S0 to VD1S3 in the VD1LS register.
2. Necessary time until the voltage detector operates when setting to 1 again after setting the VC26 bit in the VCR2 register to 0.
3. Time from when passing the V_{det1} until when a voltage monitor 1 reset is generated.

Table 5.14 Voltage Detector 2 Electrical Characteristics

The measurement condition is $V_{CC1} = 1.8$ to 5.5 V, $T_{opr} = -20^{\circ}\text{C}$ to $85^{\circ}\text{C}/-40^{\circ}\text{C}$ to 85°C , unless otherwise specified.

Symbol	Parameter	Condition	Standard			Unit
			Min.	Typ.	Max.	
V_{det2}	Voltage detection level V_{det2_0}	When V_{CC1} is falling	3.70	4.00	4.30	V
-	Hysteresis width at the rising of V_{CC1} in voltage detector 2			0.15		V
-	Voltage detector 2 response time ⁽²⁾	When V_{CC1} falls from 5 V to $(V_{det2_0} - 0.1)$ V			200	μs
-	Voltage detector self power consumption	$VC27 = 1$, $V_{CC1} = 5.0$ V		1.7		μA
$t_{d(E-A)}$	Waiting time until voltage detector operation starts ⁽¹⁾				100	μs

Notes:

- Necessary time until the voltage detector operates after setting to 1 again after setting the VC27 bit in the VCR2 register to 0.
- Time from when passing the V_{det2} until when a voltage monitor 2 reset is generated.

Table 5.15 Power-On Reset Circuit

The measurement condition is $V_{CC1} = 2.0$ to 5.5 V, $T_{opr} = -20^{\circ}\text{C}$ to $85^{\circ}\text{C}/-40^{\circ}\text{C}$ to 85°C , unless otherwise specified.

Symbol	Parameter	Condition	Standard			Unit
			Min.	Typ.	Max.	
V_{por1}	Voltage at which power-on reset enabled ⁽¹⁾				0.5	V
t_{rth}	External power V_{CC1} rise gradient		2.0		50000	mV/ms
$t_{w(por)}$	Time necessary to enable power-on reset		300			ms

Note:

- To use the power-on reset function, enable voltage monitor 0 reset by setting the LVDAS bit in the OFS1 address to 0. Also, set the VDSEL1 bit to 0 (V_{det0_2}).

**Figure 5.4 Power-On Reset Circuit Electrical Characteristics**

Table 5.16 Power Supply Circuit Timing Characteristics

The measurement condition is $V_{CC1} = 1.8$ to 5.5 V and $T_{opr} = 25^{\circ}\text{C}$, unless otherwise specified.

Symbol	Parameter	Condition	Standard			Unit
			Min.	Typ.	Max.	
$t_{d(P-R)}$	Internal power supply stability time when power is on (1)				5	ms
$t_{d(R-S)}$	STOP release time				150	μs
$t_{d(W-S)}$	Low power mode wait mode release time				150	μs

Note:

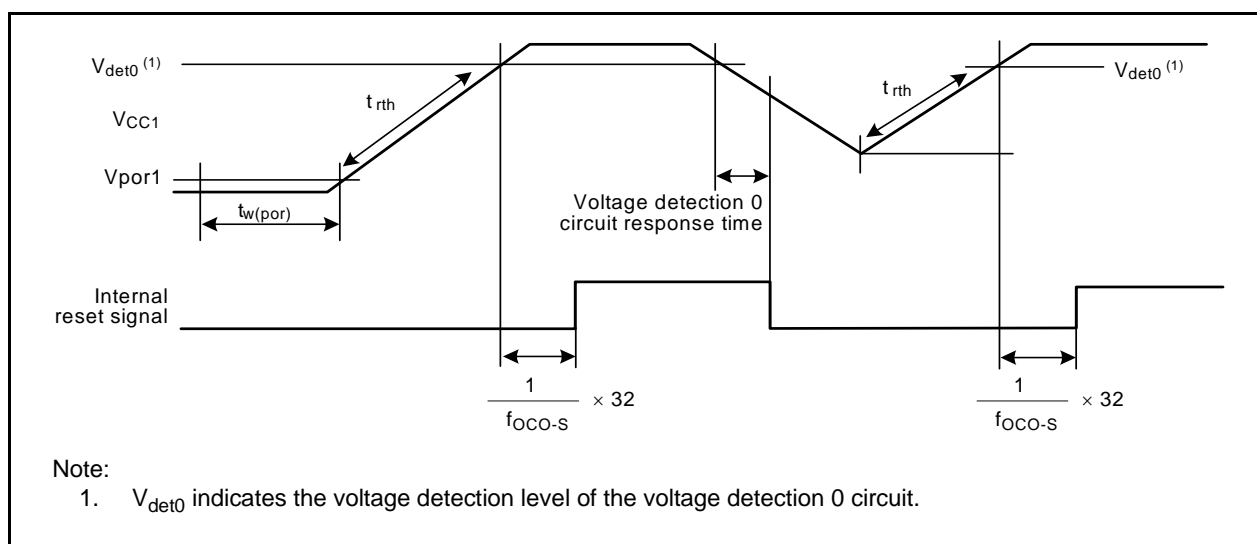
1. Waiting time until the internal power supply generator stabilizes when power is on.

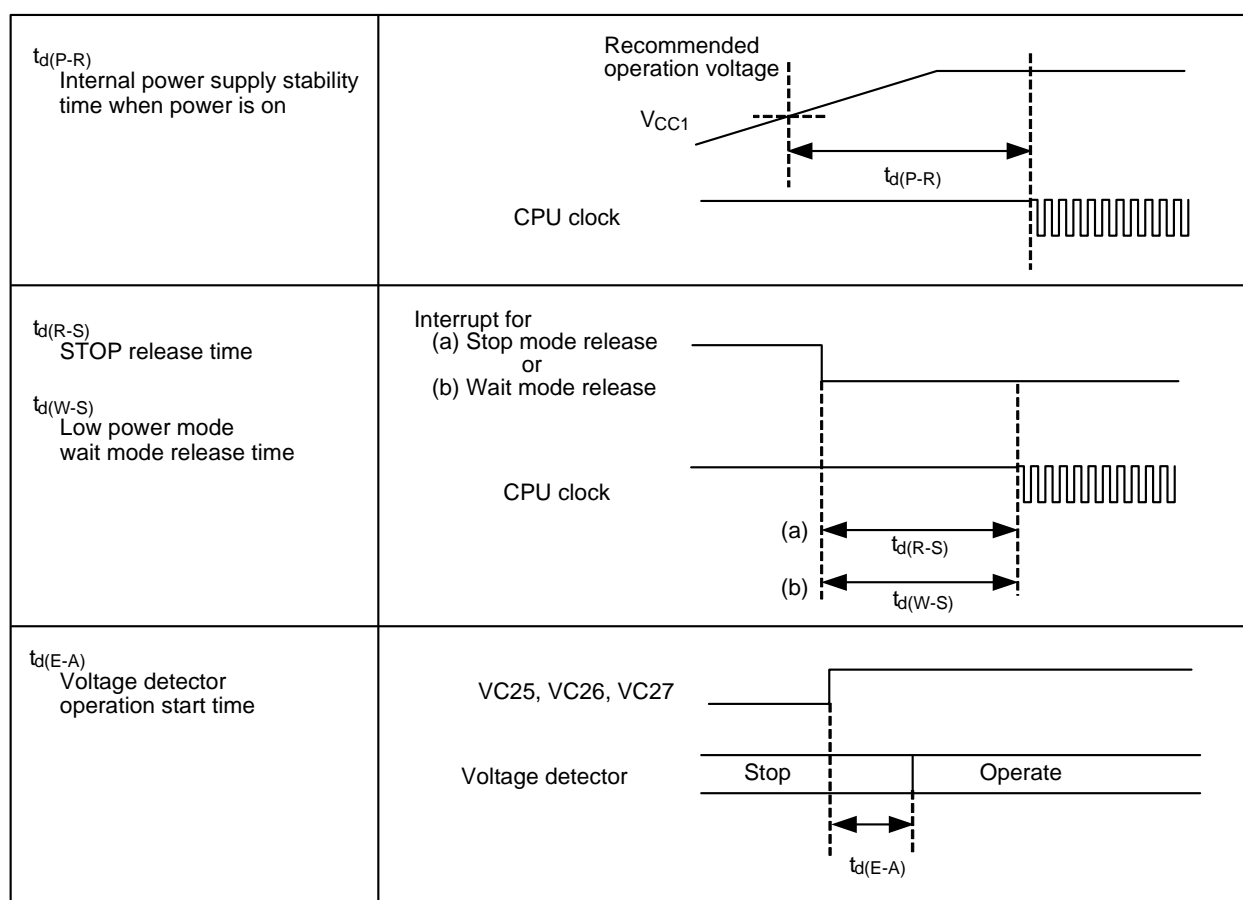

Figure 5.5 Power Supply Circuit Timing Diagram

5.1.7 Oscillator Electrical Characteristics

Table 5.17 40 MHz On-Chip Oscillator Electrical Characteristics

$V_{CC1} = 1.8$ to 5.5 V, $T_{opr} = -20^{\circ}\text{C}$ to $85^{\circ}\text{C}/-40^{\circ}\text{C}$ to 85°C , unless otherwise specified.

Symbol	Parameter	Condition	Standard			Unit
			Min.	Typ.	Max.	
f _{OCO40M}	40 MHz on-chip oscillator frequency	Average frequency in a 10 ms period $2.7\text{ V} \leq V_{CC1} < 5.5\text{ V}$	36	40	44	MHz
		Average frequency in a 10 ms period $1.8\text{ V} \leq V_{CC1} < 2.7\text{ V}$	30	40	50	MHz
tsu(f _{OCO40M})	Wait time until 40 MHz on-chip oscillator stabilizes				2	ms

Table 5.18 125 kHz On-Chip Oscillator Electrical Characteristics

$V_{CC1} = 1.8$ to 5.5 V, $T_{opr} = -20^{\circ}\text{C}$ to $85^{\circ}\text{C}/-40^{\circ}\text{C}$ to 85°C , unless otherwise specified.

Symbol	Parameter	Condition	Standard			Unit
			Min.	Typ.	Max.	
f _{OCO-s}	125 kHz on-chip oscillator frequency	Average frequency in a 10 ms period	100	125	150	kHz
tsu(f _{OCO-s})	Wait time until 125 kHz on-chip oscillator stabilizes				20	μs

5.2 Electrical Characteristics ($V_{CC1} = V_{CC2} = 5\text{ V}$)

5.2.1 Electrical Characteristics

$$V_{CC1} = V_{CC2} = 5\text{ V}$$

Table 5.19 Electrical Characteristics (1) (1)

$V_{CC1} = V_{CC2} = 4.2$ to 5.5 V , $V_{SS} = 0\text{ V}$ at $T_{opr} = -20^\circ\text{C}$ to 85°C / -40°C to 85°C , $f_{(BCLK)} = 20\text{ MHz}$ unless otherwise specified.

Symbol	Parameter		Measuring Condition	Standard			Unit	
				Min.	Typ.	Max.		
V_{OH}	High output voltage	P6_0 to P6_7, P7_2 to P7_7, P8_0 to P8_4, P8_6, P8_7, P9_0 to P9_7, P10_0 to P10_7	$I_{OH} = -5\text{ mA}$	$V_{CC1} - 2.0$		V_{CC1}	V	
		P0_0 to P0_7, P1_0 to P1_7, P2_0 to P2_7, P3_0 to P3_7, P4_0 to P4_7, P5_0 to P5_7	$I_{OH} = -5\text{ mA}$	$V_{CC2} - 2.0$		V_{CC2}		
V_{OH}	High output voltage	P6_0 to P6_7, P7_2 to P7_7, P8_0 to P8_4, P8_6, P8_7, P9_0 to P9_7, P10_0 to P10_7	$I_{OH} = -200\text{ }\mu\text{A}$	$V_{CC1} - 0.3$		V_{CC1}	V	
		P0_0 to P0_7, P1_0 to P1_7, P2_0 to P2_7, P3_0 to P3_7, P4_0 to P4_7, P5_0 to P5_7	$I_{OH} = -200\text{ }\mu\text{A}$	$V_{CC2} - 0.3$		V_{CC2}		
V_{OH}	High output voltage	XOUT	HIGHPOWER	$I_{OH} = -1\text{ mA}$	$V_{CC1} - 2.0$		V_{CC1}	V
			LOWPOWER	$I_{OH} = -0.5\text{ mA}$	$V_{CC1} - 2.0$		V_{CC1}	
	High output voltage	XCOU	With no load applied			1.5		V
V_{OL}	Low output voltage	P6_0 to P6_7, P7_0 to P7_7, P8_0 to P8_7, P9_0 to P9_7, P10_0 to P10_7	$I_{OL} = 5\text{ mA}$			2.0	V	
		P0_0 to P0_7, P1_0 to P1_7, P2_0 to P2_7, P3_0 to P3_7, P4_0 to P4_7, P5_0 to P5_7	$I_{OL} = 5\text{ mA}$			2.0		
V_{OL}	Low output voltage	P6_0 to P6_7, P7_0 to P7_7, P8_0 to P8_7, P9_0 to P9_7, P10_0 to P10_7	$I_{OL} = 200\text{ }\mu\text{A}$			0.45	V	
		P0_0 to P0_7, P1_0 to P1_7, P2_0 to P2_7, P3_0 to P3_7, P4_0 to P4_7, P5_0 to P5_7	$I_{OL} = 200\text{ }\mu\text{A}$			0.45		
V_{OL}	Low output voltage	XOUT	HIGHPOWER	$I_{OL} = 1\text{ mA}$			2.0	V
			LOWPOWER	$I_{OL} = 0.5\text{ mA}$			2.0	
	Low output voltage	XCOU	With no load applied			0		V

Note:

1. When $V_{CC1} \neq V_{CC2}$, refer to 5 V, 3 V, or 1.8 V standard depending on the voltage.

$$V_{CC1} = V_{CC2} = 5 \text{ V}$$

Table 5.20 Electrical Characteristics (2) (1)
 $V_{CC1} = V_{CC2} = 4.2 \text{ to } 5.5 \text{ V}$, $V_{SS} = 0 \text{ V}$ at $T_{opr} = -20^\circ\text{C to } 85^\circ\text{C} / -40^\circ\text{C to } 85^\circ\text{C}$, $f_{(BCLK)} = 20 \text{ MHz}$ unless otherwise specified.

Symbol	Parameter	Measuring Condition	Standard			Unit	
			Min.	Typ.	Max.		
$V_{T+} - V_{T-}$	Hysteresis	HOLD, RDY, TA0IN to TA4IN, TB0IN to TB5IN, INT0 to INT7, NMI, ADTRG, CTS0 to CTS2, CTS5 to CTS7, SCL0 to SCL2, SCL5 to SCL7, SDA0 to SDA2, SDA5 to SDA7, CLK0 to CLK7, TA0OUT to TA4OUT, KI0 to KI7, RXD0 to RXD2, RXD5 to RXD7, SIN3, SIN4, SD, PMC0, PMC1, SCLMM, SDAMM, CEC, ZP, IDU, IDV, IDW		0.5		2.0	V
$V_{T+} - V_{T-}$	Hysteresis	RESET		0.5		2.5	V
I_{IH}	High input current	P0_0 to P0_7, P1_0 to P1_7, P2_0 to P2_7, P3_0 to P3_7, P4_0 to P4_7, P5_0 to P5_7, P6_0 to P6_7, P7_0 to P7_7, P8_0 to P8_7, P9_0 to P9_7, P10_0 to P10_7 XIN, RESET, CNVSS, BYTE	$V_I = 5 \text{ V}$			5.0	μA
I_{IL}	Low input current	P0_0 to P0_7, P1_0 to P1_7, P2_0 to P2_7, P3_0 to P3_7, P4_0 to P4_7, P5_0 to P5_7, P6_0 to P6_7, P7_0 to P7_7, P8_0 to P8_7, P9_0 to P9_7, P10_0 to P10_7 XIN, RESET, CNVSS, BYTE	$V_I = 0 \text{ V}$			-5.0	μA
R_{PULLUP}	Pull-up resistance	P0_0 to P0_7, P1_0 to P1_7, P2_0 to P2_7, P3_0 to P3_7, P4_0 to P4_7, P5_0 to P5_7, P6_0 to P6_7, P7_2 to P7_7, P8_0 to P8_4, P8_6, P8_7, P9_0 to P9_7, P10_0 to P10_7	$V_I = 0 \text{ V}$	30	50	170	$\text{k}\Omega$
R_{fXIN}	Feedback resistance XIN				0.8		$\text{M}\Omega$
R_{fXCIN}	Feedback resistance XCIN				8		$\text{M}\Omega$
V_{RAM}	RAM retention voltage	In stop mode		1.8			V

Note:

1. When $V_{CC1} \neq V_{CC2}$, refer to 5 V, 3 V, or 1.8 V standard depending on the voltage.

$$V_{CC1} = V_{CC2} = 5 \text{ V}$$

Table 5.21 Electrical Characteristics (3)
 $V_{CC1} = V_{CC2} = 4.2 \text{ to } 5.5 \text{ V}$, $V_{SS} = 0 \text{ V}$ at $T_{opr} = -20^\circ\text{C}$ to 85°C / -40°C to 85°C , $f_{(BCLK)} = 20 \text{ MHz}$ unless otherwise specified.

Symbol	Parameter	Measuring Condition	Standard			Unit
			Min.	Typ.	Max.	
I _{CC}	Power supply current In single-chip, mode, the output pin are open and other pins are V _{SS}	High-speed mode	f _(BCLK) = 20 MHz (no division) XIN = 20 MHz (square wave) 125 kHz on-chip oscillator stopped CM15 = 1 (drive capacity High) A/D converter stopped		10.7	mA
			f _(BCLK) = 20 MHz (no division) XIN = 20 MHz (square wave) 125 kHz on-chip oscillator stopped CM15 = 1 (drive capacity High) A/D converter operating (2)		11.4	mA
			f _(BCLK) = 20 MHz XIN = 20 MHz (square wave) 125 kHz on-chip oscillator stopped CM15 = 0 (drive capacity Low) A/D converter stopped		10.1	mA
			f _(BCLK) = 20 MHz (no division) XIN = 20 MHz (square wave) 125 kHz on-chip oscillator stopped CM15 = 1 (drive capacity High) PCLKSTP1 = FF (peripheral clock stop)		9.1	mA
			f _(BCLK) = 20 MHz (no division) XIN = 20 MHz (square wave) 125 kHz on-chip oscillator stopped CM15 = 0 (drive capacity Low) PCLKSTP1 = FF (peripheral clock stopped)		8.5	mA
		40 MHz on-chip oscillator mode	Main clock stopped 40 MHz on-chip oscillator on, divide-by-2 (f _(BCLK) = 20 MHz) 125 kHz on-chip oscillator stopped		9.0	mA
		125 kHz on-chip oscillator mode	Main clock stopped 40 MHz on-chip oscillator stopped, 125 kHz on-chip oscillator on, no division FMR22 = 1 (slow read mode)		450.0	μA
		Low-power mode	f _(BCLK) = 32 kHz FMR22 = FMR23 = 1 (in low current consumption read mode) On flash memory (1)		80.0	μA
		Wait mode	f _(BCLK) = 32 kHz Main clock stopped 40 MHz on-chip oscillator stopped 125 kHz on-chip oscillator on PM25 = 1 (peripheral function clock fC operating) T _{opr} = 25°C Real-time clock operating		5.6	μA
			f _(BCLK) = 32 kHz Main clock stopped 40 MHz on-chip oscillator stopped 125 kHz on-chip oscillator stopped PM25 = 0 (peripheral function clock fC stopped) T _{opr} = 25°C		5.3	μA
		Stop mode	T _{opr} = 25°C		2.4	μA
		During flash memory program	f _(BCLK) = 10 MHz, PM17 = 1 (one wait) V _{CC1} = 5.0 V		20.0	mA
During flash memory erase	f _(BCLK) = 10 MHz, PM17 = 1 (one wait) V _{CC1} = 5.0 V		30.0	mA		

Notes:

- This indicates the memory in which the program to be executed exists.
- A/D conversion is executed in repeat mode.

$$V_{CC1} = V_{CC2} = 5 \text{ V}$$

5.2.2 Timing Requirements (Peripheral Functions and Others)

($V_{CC1} = V_{CC2} = 5 \text{ V}$, $V_{SS} = 0 \text{ V}$, at $T_{opr} = -20^{\circ}\text{C}$ to $85^{\circ}\text{C}/-40^{\circ}\text{C}$ to 85°C unless otherwise specified)

5.2.2.1 Reset Input ($\overline{\text{RESET}}$ Input)

Table 5.22 Reset Input ($\overline{\text{RESET}}$ Input)

Symbol	Parameter	Standard		Unit
		Min.	Max.	
$t_{w(\text{RSTL})}$	$\overline{\text{RESET}}$ input low pulse width	10		μs

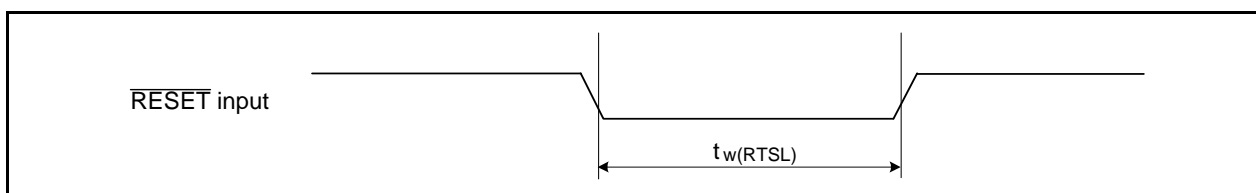

Figure 5.6 Reset Input ($\overline{\text{RESET}}$ Input)

5.2.2.2 External Clock Input

Table 5.23 External Clock Input (XIN Input) (1)

Symbol	Parameter	Standard		Unit
		Min.	Max.	
t_c	External clock input cycle time	50		ns
$t_{w(\text{H})}$	External clock input high pulse width	20		ns
$t_{w(\text{L})}$	External clock input low pulse width	20		ns
t_r	External clock rise time		9	ns
t_f	External clock fall time		9	ns

Note:

- The condition is $V_{CC1} = V_{CC2} = 3.0$ to 5.0 V .

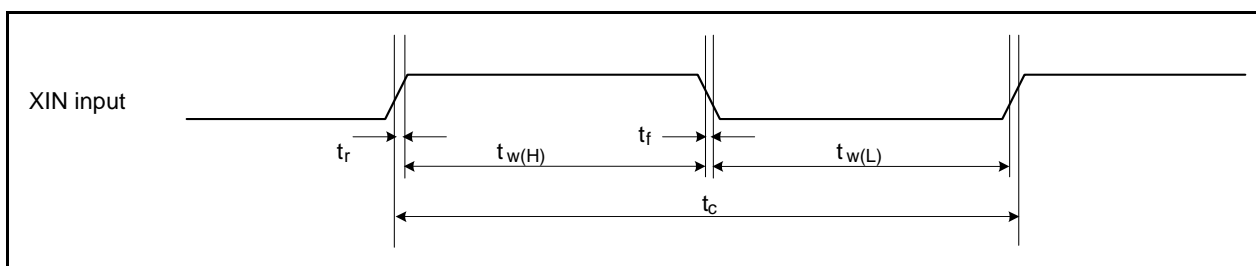

Figure 5.7 External Clock Input (XIN Input)

$$V_{CC1} = V_{CC2} = 5 \text{ V}$$

Timing Requirements

($V_{CC1} = V_{CC2} = 5 \text{ V}$, $V_{SS} = 0 \text{ V}$, at $T_{opr} = -20^\circ\text{C}$ to $85^\circ\text{C}/-40^\circ\text{C}$ to 85°C unless otherwise specified)

5.2.2.3 Timer A Input

Table 5.24 Timer A Input (Counter Input in Event Counter Mode)

Symbol	Parameter	Standard		Unit
		Min.	Max.	
$t_{c(TA)}$	TAiIN input cycle time	100		ns
$t_{w(TAH)}$	TAiIN input high pulse width	40		ns
$t_{w(TAL)}$	TAiIN input low pulse width	40		ns

Table 5.25 Timer A Input (Gating Input in Timer Mode)

Symbol	Parameter	Standard		Unit
		Min.	Max.	
$t_{c(TA)}$	TAiIN input cycle time	400		ns
$t_{w(TAH)}$	TAiIN input high pulse width	200		ns
$t_{w(TAL)}$	TAiIN input low pulse width	200		ns

Table 5.26 Timer A Input (External Trigger Input in One-Shot Timer Mode)

Symbol	Parameter	Standard		Unit
		Min.	Max.	
$t_{c(TA)}$	TAiIN input cycle time	200		ns
$t_{w(TAH)}$	TAiIN input high pulse width	100		ns
$t_{w(TAL)}$	TAiIN input low pulse width	100		ns

Table 5.27 Timer A Input (External Trigger Input in Pulse Width Modulation Mode and Programmable Output Mode)

Symbol	Parameter	Standard		Unit
		Min.	Max.	
$t_{w(TAH)}$	TAiIN input high pulse width	100		ns
$t_{w(TAL)}$	TAiIN input low pulse width	100		ns

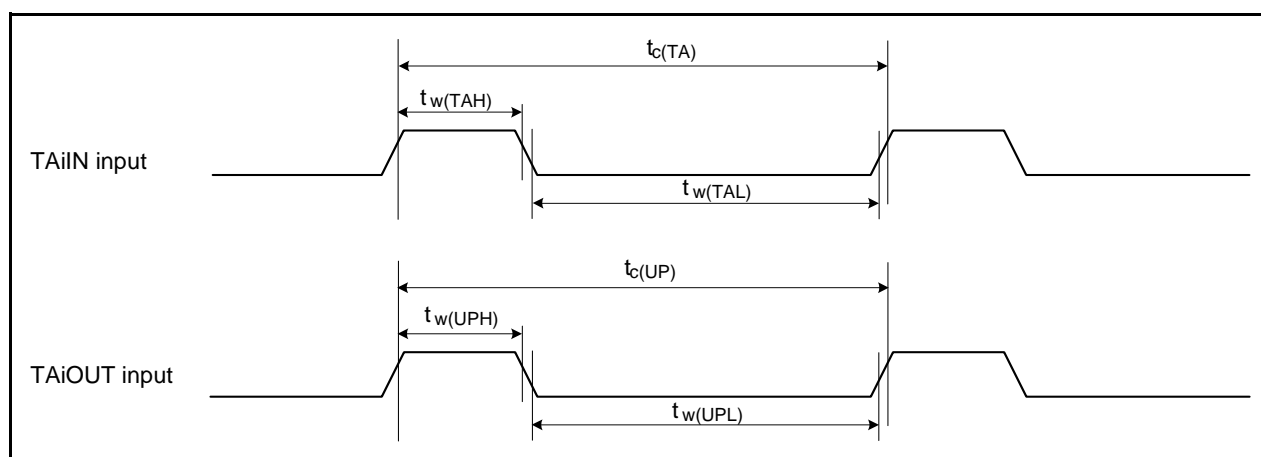

Figure 5.8 Timer A Input

$$V_{CC1} = V_{CC2} = 5 \text{ V}$$

Timing Requirements

($V_{CC1} = V_{CC2} = 5 \text{ V}$, $V_{SS} = 0 \text{ V}$, at $T_{opr} = -20^\circ\text{C}$ to $85^\circ\text{C}/-40^\circ\text{C}$ to 85°C unless otherwise specified)

Table 5.28 Timer A Input (Two-Phase Pulse Input in Event Counter Mode)

Symbol	Parameter	Standard		Unit
		Min.	Max.	
$t_{c(TA)}$	TAiIN input cycle time	800		ns
$t_{su(TAIN-TAOUT)}$	TAiOUT input setup time	200		ns
$t_{su(TAOUT-TAIN)}$	TAiIN input setup time	200		ns

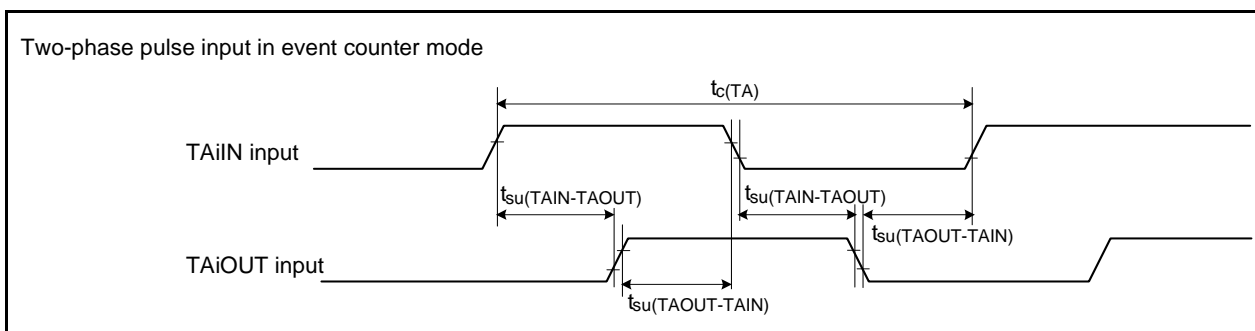
**Figure 5.9 Timer A Input (Two-Phase Pulse Input in Event Counter Mode)**

$$V_{CC1} = V_{CC2} = 5 \text{ V}$$

Timing Requirements

($V_{CC1} = V_{CC2} = 5 \text{ V}$, $V_{SS} = 0 \text{ V}$, at $T_{opr} = -20^\circ\text{C}$ to $85^\circ\text{C}/-40^\circ\text{C}$ to 85°C unless otherwise specified)

5.2.2.4 Timer B Input

Table 5.29 Timer B Input (Counter Input in Event Counter Mode)

Symbol	Parameter	Standard		Unit
		Min.	Max.	
$t_{c(TB)}$	TBiIN input cycle time (counted on one edge)	100		ns
$t_{w(TBH)}$	TBiIN input high pulse width (counted on one edge)	40		ns
$t_{w(TBL)}$	TBiIN input low pulse width (counted on one edge)	40		ns
$t_{c(TB)}$	TBiIN input cycle time (counted on both edges)	200		ns
$t_{w(TBH)}$	TBiIN input high pulse width (counted on both edges)	80		ns
$t_{w(TBL)}$	TBiIN input low pulse width (counted on both edges)	80		ns

Table 5.30 Timer B Input (Pulse Period Measurement Mode)

Symbol	Parameter	Standard		Unit
		Min.	Max.	
$t_{c(TB)}$	TBiIN input cycle time	400		ns
$t_{w(TBH)}$	TBiIN input high pulse width	200		ns
$t_{w(TBL)}$	TBiIN input low pulse width	200		ns

Table 5.31 Timer B Input (Pulse Width Measurement Mode)

Symbol	Parameter	Standard		Unit
		Min.	Max.	
$t_{c(TB)}$	TBiIN input cycle time	400		ns
$t_{w(TBH)}$	TBiIN input high pulse width	200		ns
$t_{w(TBL)}$	TBiIN input low pulse width	200		ns

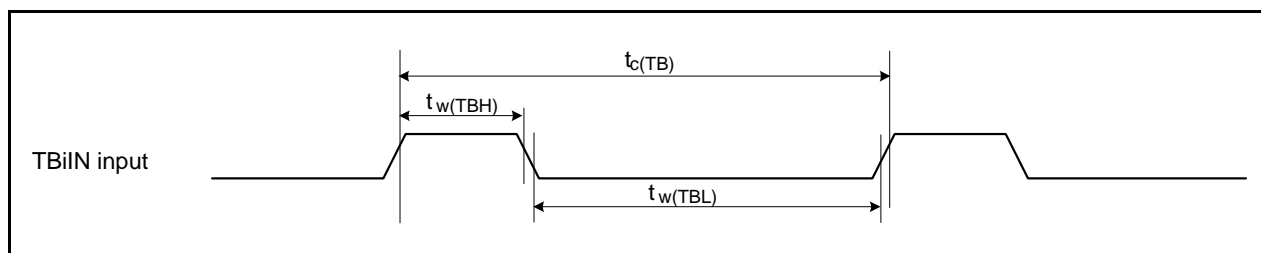

Figure 5.10 Timer B Input

$$V_{CC1} = V_{CC2} = 5\text{ V}$$

Timing Requirements

($V_{CC1} = V_{CC2} = 5\text{ V}$, $V_{SS} = 0\text{ V}$, at $T_{opr} = -20^{\circ}\text{C}$ to 85°C / -40°C to 85°C unless otherwise specified)

5.2.2.5 Serial Interface

Table 5.32 Serial Interface

Symbol	Parameter	Standard		Unit
		Min.	Max.	
$t_c(\text{CK})$	CLKi input cycle time	200		ns
$t_w(\text{CKH})$	CLKi input high pulse width	100		ns
$t_w(\text{CKL})$	CLKi input low pulse width	100		ns
$t_d(\text{C-Q})$	TXDi output delay time		80	ns
$t_h(\text{C-Q})$	TXDi hold time	0		ns
$t_{su}(\text{D-C})$	RXDi input setup time	70		ns
$t_h(\text{C-D})$	RXDi input hold time	90		ns

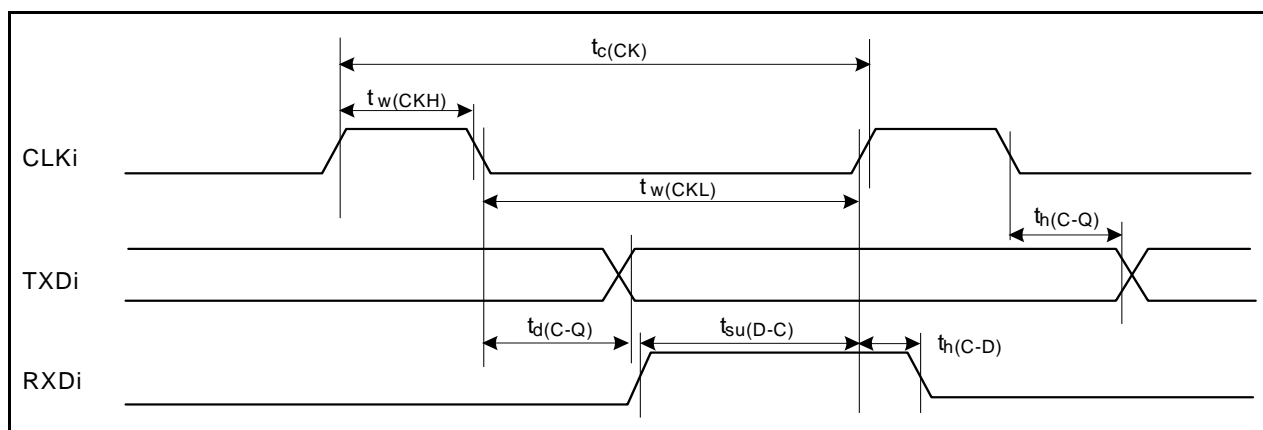

Figure 5.11 Serial Interface

5.2.2.6 External Interrupt $\overline{\text{INT}}_i$ Input

Table 5.33 External Interrupt $\overline{\text{INT}}_i$ Input

Symbol	Parameter	Standard		Unit
		Min.	Max.	
$t_w(\text{INH})$	$\overline{\text{INT}}_i$ input high pulse width	250		ns
$t_w(\text{INL})$	$\overline{\text{INT}}_i$ input low pulse width	250		ns

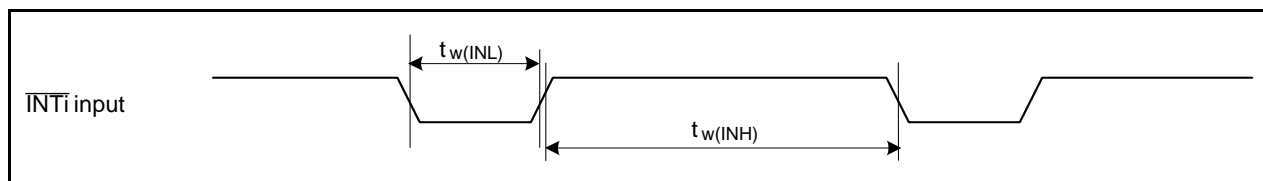

Figure 5.12 External Interrupt $\overline{\text{INT}}_i$ Input

$$V_{CC1} = V_{CC2} = 5\text{ V}$$

Timing Requirements

($V_{CC1} = V_{CC2} = 5\text{ V}$, $V_{SS} = 0\text{ V}$, at $T_{opr} = -20^{\circ}\text{C}$ to 85°C / -40°C to 85°C unless otherwise specified)

5.2.2.7 Multi-master I²C-bus

Table 5.34 Multi-master I²C-bus

Symbol	Parameter	Standard Clock Mode		Fast-mode		Unit
		Min.	Max.	Min.	Max.	
t_{BUF}	Bus free time	4.7		1.3		μs
$t_{HD;STA}$	Hold time in start condition	4.0		0.6		μs
t_{LOW}	Hold time in SCL clock 0 status	4.7		1.3		μs
t_R	SCL, SDA signals' rising time		1000	$20 + 0.1 C_b$	300	ns
$t_{HD;DAT}$	Data hold time	0		0	0.9	μs
t_{HIGH}	Hold time in SCL clock 1 status	4.0		0.6		μs
t_F	SCL, SDA signals' falling time		300	$20 + 0.1 C_b$	300	ns
$t_{su;DAT}$	Data setup time	250		100		ns
$t_{su;STA}$	Setup time in restart condition	4.7		0.6		μs
$t_{su;STO}$	Stop condition setup time	4.0		0.6		μs

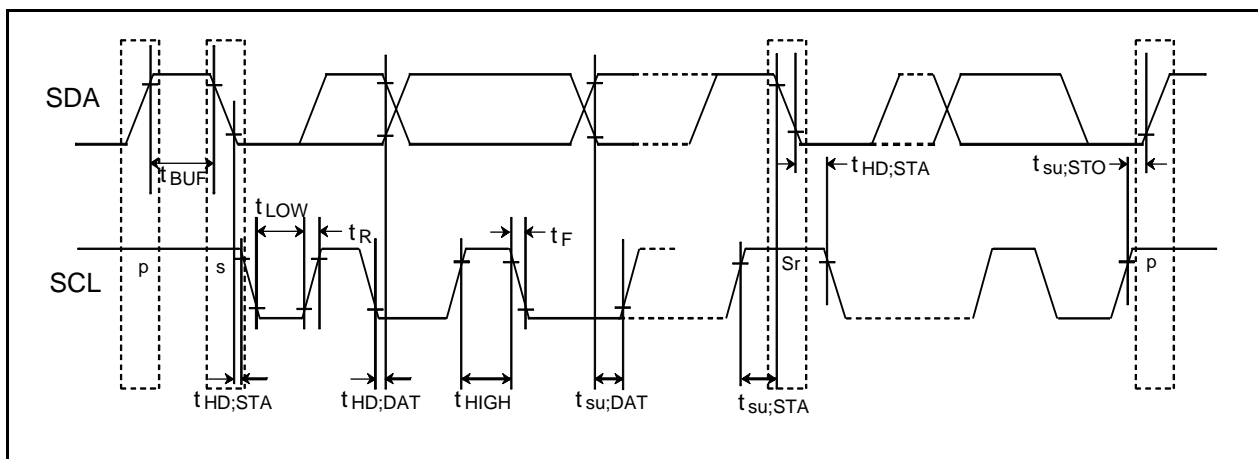

Figure 5.13 Multi-master I²C-bus

$$V_{CC1} = V_{CC2} = 5 V$$

Timing Requirements

($V_{CC1} = V_{CC2} = 5 V$, $V_{SS} = 0 V$, at $T_{opr} = -20^{\circ}C$ to $85^{\circ}C$ / $-40^{\circ}C$ to $85^{\circ}C$ unless otherwise specified)

5.2.3 Timing Requirements (Memory Expansion Mode and Microprocessor Mode)

Table 5.35 Memory Expansion Mode and Microprocessor Mode

Symbol	Parameter	Standard		Unit
		Min.	Max.	
$t_{ac1}(RD-DB)$	Data input access time (for setting with no wait)		(Note 1)	ns
$t_{ac2}(RD-DB)$	Data input access time (for setting with 1 to 3 waits)		(Note 2)	ns
$t_{ac3}(RD-DB)$	Data input access time (when accessing multiplex bus area)		(Note 3)	ns
$t_{ac4}(RD-DB)$	Data input access time (for setting with $2\phi + 3\phi$ or more)		(Note 4)	ns
$t_{su}(DB-RD)$	Data input setup time	40		ns
$t_{su}(RDY-BCLK)$	\overline{RDY} input setup time	80		ns
$t_h(RD-DB)$	Data input hold time	0		ns
$t_h(BCLK-RDY)$	\overline{RDY} input hold time	0		ns

Notes:

1. Calculated according to the BCLK frequency as follows:

$$\frac{0.5 \times 10^9}{f_{(BCLK)}} - 45 [ns]$$

2. Calculated according to the BCLK frequency as follows:

$$\frac{(n + 0.5) \times 10^9}{f_{(BCLK)}} - 45 [ns] \quad n \text{ is 1 for 1 wait setting, 2 for 2 waits setting and 3 for 3 waits setting.}$$

3. Calculated according to the BCLK frequency as follows:

$$\frac{(n - 0.5) \times 10^9}{f_{(BCLK)}} - 45 [ns] \quad n \text{ is 2 for 2 waits setting, and 3 for 3 waits setting.}$$

4. Calculated according to the BCLK frequency as follows:

$$\frac{n \times 10^9}{f_{(BCLK)}} - 45 [ns] \quad n \text{ is 3 for } 2\phi + 3\phi, 4 \text{ for } 2\phi + 4\phi, 4 \text{ for } 3\phi + 4\phi, \text{ and } 5 \text{ for } 4\phi + 5\phi.$$

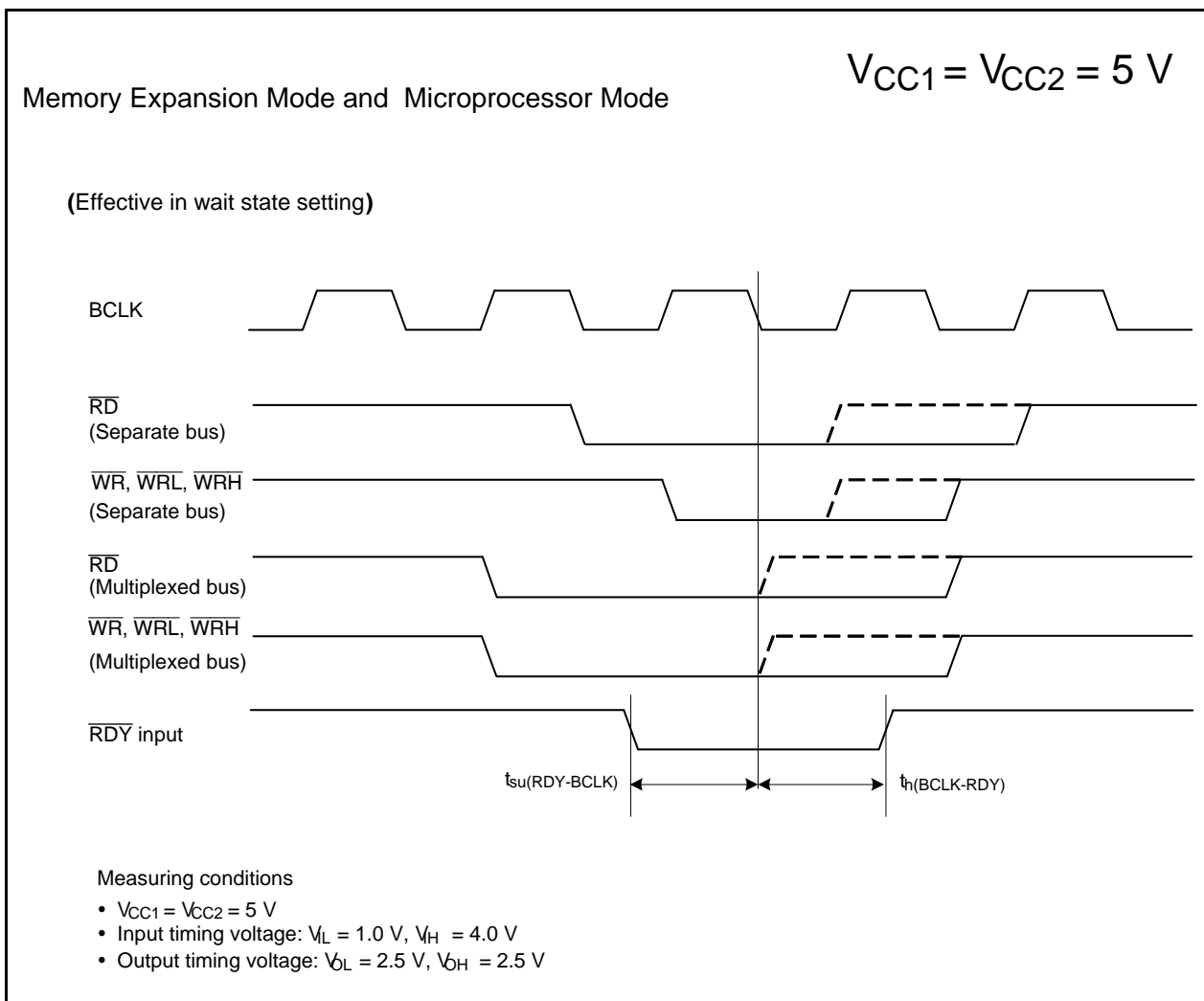

Figure 5.14 Timing Diagram

$$V_{CC1} = V_{CC2} = 5 \text{ V}$$

5.2.4 Switching Characteristics (Memory Expansion Mode and Microprocessor Mode)

($V_{CC1} = V_{CC2} = 5 \text{ V}$, $V_{SS} = 0 \text{ V}$, at $T_{opr} = -20^{\circ}\text{C}$ to $85^{\circ}\text{C}/-40^{\circ}\text{C}$ to 85°C unless otherwise specified)

5.2.4.1 In No Wait State Setting

Table 5.36 Memory Expansion Mode and Microprocessor Mode (in No Wait State Setting)

Symbol	Parameter	Measuring Condition	Standard		Unit
			Min.	Max.	
$t_{d(\text{BCLK-AD})}$	Address output delay time	See Figure 5.15		25	ns
$t_{h(\text{BCLK-AD})}$	Address output hold time (in relation to BCLK)		0		ns
$t_{h(\text{RD-AD})}$	Address output hold time (in relation to RD)		0		ns
$t_{h(\text{WR-AD})}$	Address output hold time (in relation to WR)		(Note 2)		ns
$t_{d(\text{BCLK-CS})}$	Chip select output delay time			25	ns
$t_{h(\text{BCLK-CS})}$	Chip select output hold time (in relation to BCLK)		0		ns
$t_{d(\text{BCLK-ALE})}$	ALE signal output delay time			15	ns
$t_{h(\text{BCLK-ALE})}$	ALE signal output hold time		-4		ns
$t_{d(\text{BCLK-RD})}$	RD signal output delay time			25	ns
$t_{h(\text{BCLK-RD})}$	RD signal output hold time		0		ns
$t_{d(\text{BCLK-WR})}$	WR signal output delay time			25	ns
$t_{h(\text{BCLK-WR})}$	WR signal output hold time		0		ns
$t_{d(\text{BCLK-DB})}$	Data output delay time (in relation to BCLK)			40	ns
$t_{h(\text{BCLK-DB})}$	Data output hold time (in relation to BCLK) ⁽³⁾		0		ns
$t_{d(\text{DB-WR})}$	Data output delay time (in relation to WR)		(Note 1)		ns
$t_{h(\text{WR-DB})}$	Data output hold time (in relation to WR) ⁽³⁾		(Note 2)		ns

Notes:

1. Calculated according to the BCLK frequency as follows:

$$\frac{0.5 \times 10^9}{f_{(\text{BCLK})}} - 40[\text{ns}] \quad f_{(\text{BCLK})} \text{ is } 12.5 \text{ MHz or less.}$$

2. Calculated according to the BCLK frequency as follows:

$$\frac{0.5 \times 10^9}{f_{(\text{BCLK})}} - 10[\text{ns}]$$

3. This standard value shows the timing when the output is off, and does not show hold time of data bus.

Hold time of data bus varies with capacitor volume and pull-up (pull-down) resistance value.

Hold time of data bus is expressed in

$$t = -CR \times \ln(1 - V_{OL}/V_{CC2})$$

by a circuit of the right figure.

For example, when $V_{OL} = 0.2V_{CC2}$, $C = 30 \text{ pF}$, $R = 1 \text{ k}\Omega$, hold time of output low level is

$$t = -30 \text{ pF} \times 1 \text{ k}\Omega \times \ln(1 - 0.2V_{CC2}/V_{CC2}) \\ = 6.7 \text{ ns.}$$

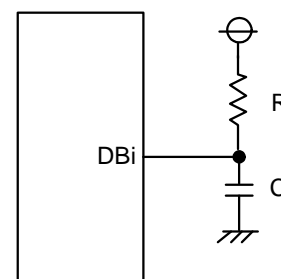

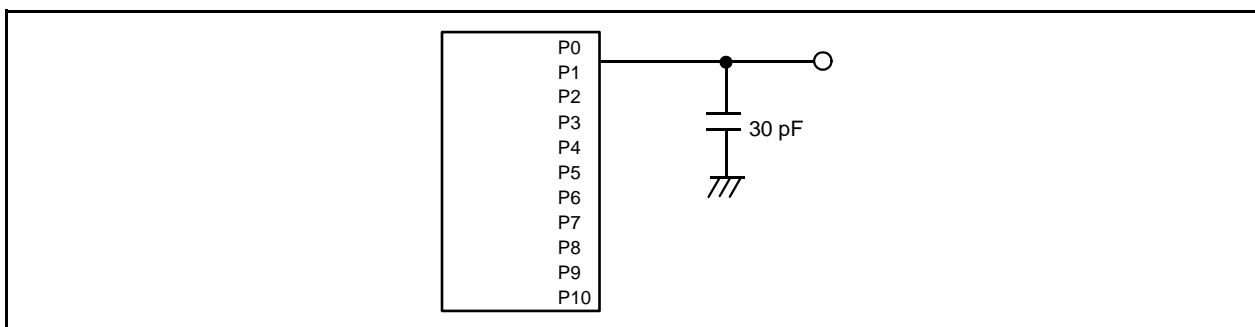

Figure 5.15 Ports P0 to P10 Measurement Circuit

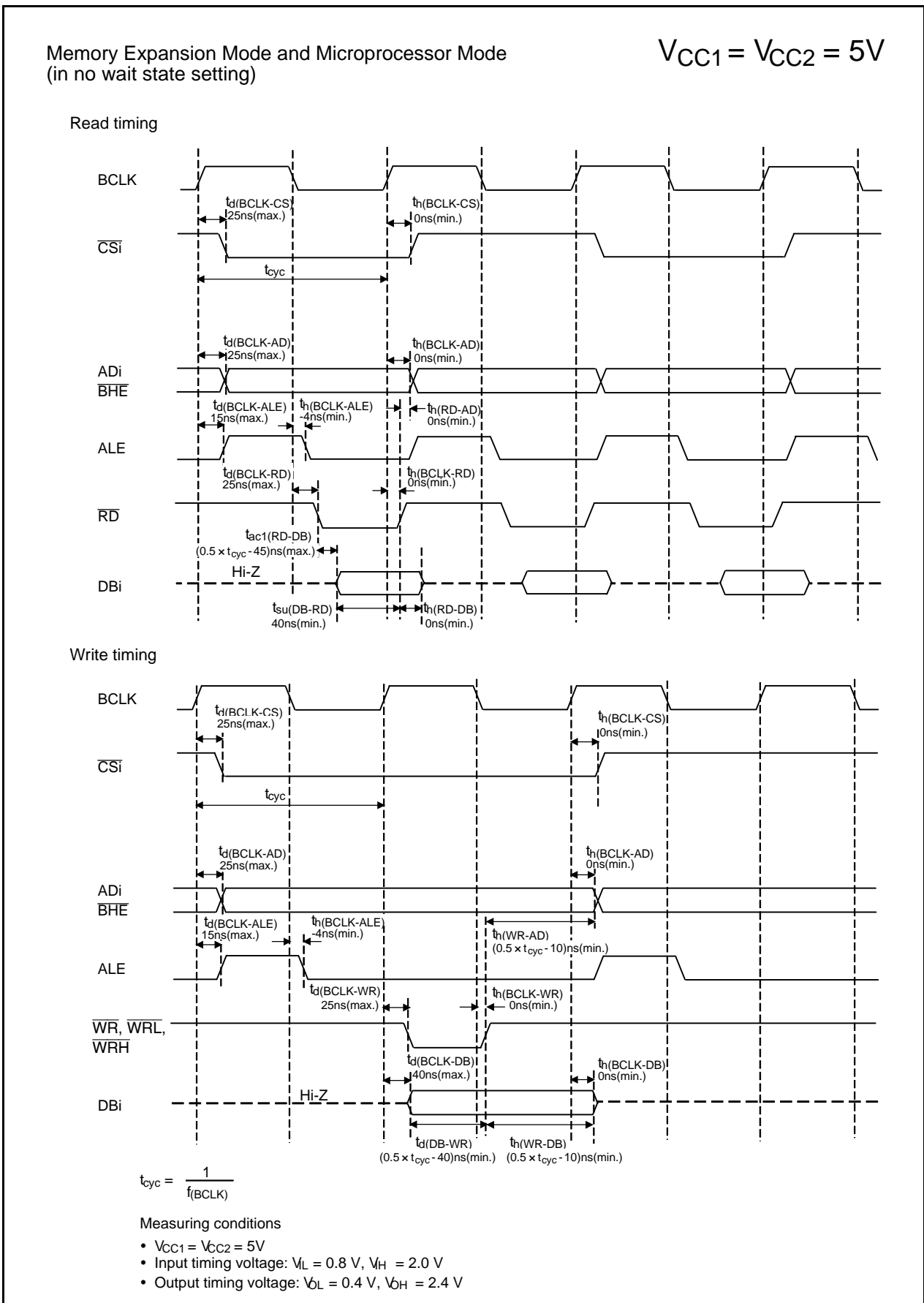

Figure 5.16 Timing Diagram

$$V_{CC1} = V_{CC2} = 5 \text{ V}$$

Switching Characteristics

($V_{CC1} = V_{CC2} = 5 \text{ V}$, $V_{SS} = 0 \text{ V}$, at $T_{opr} = -20^\circ\text{C}$ to $85^\circ\text{C}/-40^\circ\text{C}$ to 85°C unless otherwise specified)

5.2.4.2 In 1 to 3 Waits Setting and When Accessing External Area

Table 5.37 Memory Expansion Mode and Microprocessor Mode (in 1 to 3 Waits Setting and When Accessing External Area)

Symbol	Parameter	Measuring Condition	Standard		Unit
			Min.	Max.	
$t_{d(BCLK-AD)}$	Address output delay time	See Figure 5.15		25	ns
$t_{h(BCLK-AD)}$	Address output hold time (in relation to BCLK)		0		ns
$t_{h(RD-AD)}$	Address output hold time (in relation to RD)		0		ns
$t_{h(WR-AD)}$	Address output hold time (in relation to WR)		(Note 2)		ns
$t_{d(BCLK-CS)}$	Chip select output delay time			25	ns
$t_{h(BCLK-CS)}$	Chip select output hold time (in relation to BCLK)		0		ns
$t_{d(BCLK-ALE)}$	ALE signal output delay time			15	ns
$t_{h(BCLK-ALE)}$	ALE signal output hold time		-4		ns
$t_{d(BCLK-RD)}$	RD signal output delay time			25	ns
$t_{h(BCLK-RD)}$	RD signal output hold time		0		ns
$t_{d(BCLK-WR)}$	WR signal output delay time			25	ns
$t_{h(BCLK-WR)}$	WR signal output hold time		0		ns
$t_{d(BCLK-DB)}$	Data output delay time (in relation to BCLK)			40	ns
$t_{h(BCLK-DB)}$	Data output hold time (in relation to BCLK) ⁽³⁾		0		ns
$t_{d(DB-WR)}$	Data output delay time (in relation to WR)		(Note 1)		ns
$t_{h(WR-DB)}$	Data output hold time (in relation to WR) ⁽³⁾		(Note 2)		ns

Notes:

1. Calculated according to the BCLK frequency as follows:

$$\frac{(n-0.5) \times 10^9}{f_{(BCLK)}} - 40 [ns] \quad \begin{array}{l} n \text{ is 1 for 1 wait setting, 2 for 2 waits setting and 3 for 3 waits setting.} \\ \text{When } n = 1, f_{(BCLK)} \text{ is 12.5 MHz or less.} \end{array}$$

2. Calculated according to the BCLK frequency as follows:

$$\frac{0.5 \times 10^9}{f_{(BCLK)}} - 10 [ns]$$

3. This standard value shows the timing when the output is off, and does not show hold time of data bus. Hold time of data bus varies with capacitor volume and pull-up (pull-down) resistance value.

Hold time of data bus is expressed in

$$t = -CR \times \ln(1 - V_{OL}/V_{CC2})$$

by a circuit of the right figure.

For example, when $V_{OL} = 0.2V_{CC2}$, $C = 30 \text{ pF}$, $R = 1 \text{ k}\Omega$, hold

time of output low level is

$$t = -30 \text{ pF} \times 1 \text{ k}\Omega \times \ln(1 - 0.2V_{CC2}/V_{CC2})$$

$$= 6.7 \text{ ns.}$$

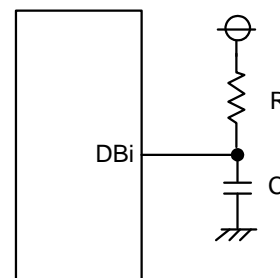

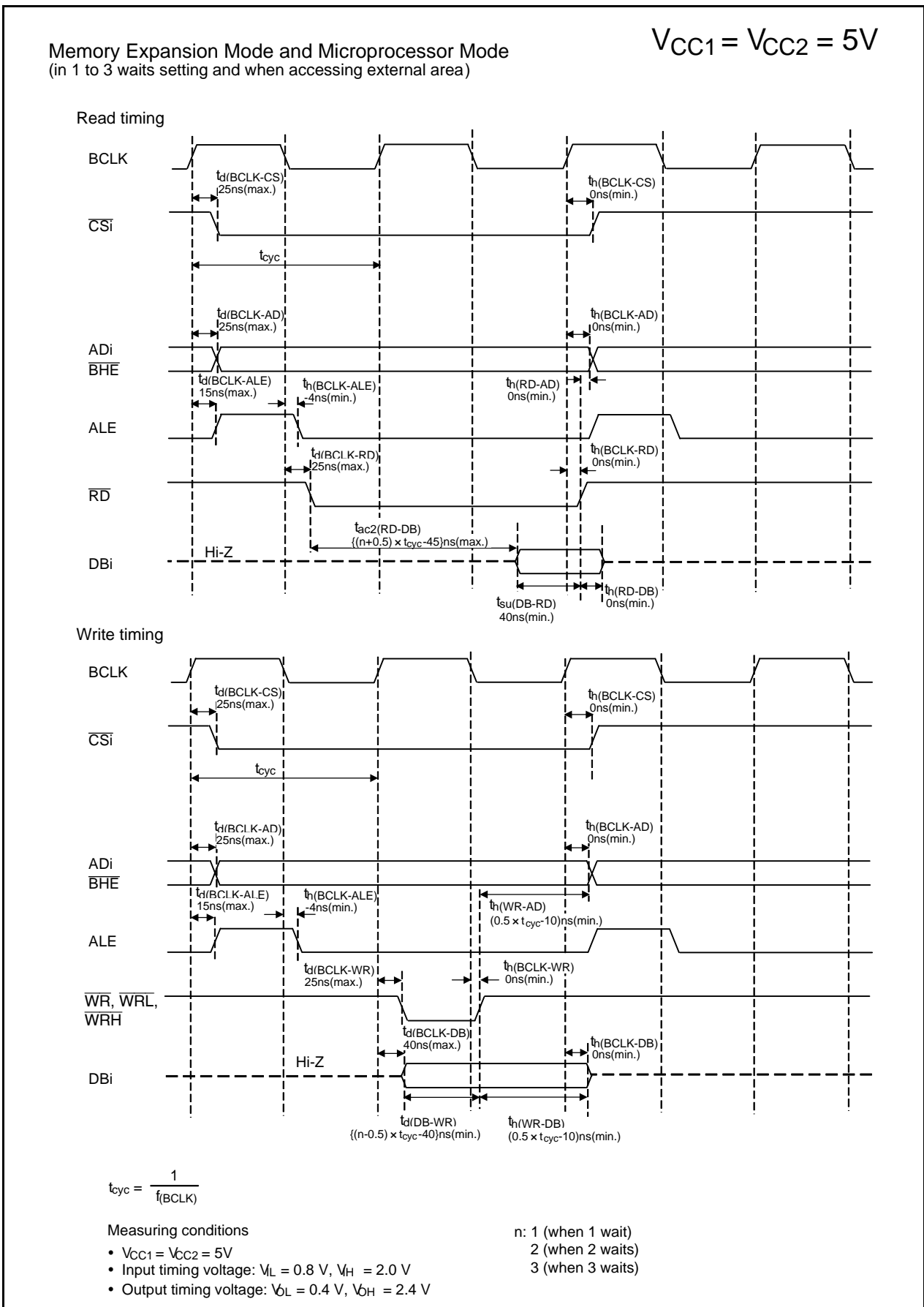

Figure 5.17 Timing Diagram

$$V_{CC1} = V_{CC2} = 5 \text{ V}$$

Switching Characteristics

($V_{CC1} = V_{CC2} = 5 \text{ V}$, $V_{SS} = 0 \text{ V}$, at $T_{opr} = -20^\circ\text{C}$ to $85^\circ\text{C}/-40^\circ\text{C}$ to 85°C unless otherwise specified)

5.2.4.3 In 2 or 3 Waits Setting, and When Accessing External Area and Using Multiplexed Bus

Table 5.38 Memory Expansion Mode and Microprocessor Mode (in 2 or 3 Waits Setting, and When Accessing External Area and Using Multiplexed Bus) (5)

Symbol	Parameter	Measuring Condition	Standard		Unit
			Min.	Max.	
$t_{d(BCLK-AD)}$	Address output delay time	See Figure 5.15		25	ns
$t_{h(BCLK-AD)}$	Address output hold time (in relation to BCLK)		0		ns
$t_{h(RD-AD)}$	Address output hold time (in relation to RD)		(Note 1)		ns
$t_{h(WR-AD)}$	Address output hold time (in relation to WR)		(Note 1)		ns
$t_{d(BCLK-CS)}$	Chip select output delay time			25	ns
$t_{h(BCLK-CS)}$	Chip select output hold time (in relation to BCLK)		0		ns
$t_{h(RD-CS)}$	Chip select output hold time (in relation to RD)		(Note 1)		ns
$t_{h(WR-CS)}$	Chip select output hold time (in relation to WR)		(Note 1)		ns
$t_{d(BCLK-RD)}$	RD signal output delay time			25	ns
$t_{h(BCLK-RD)}$	RD signal output hold time		0		ns
$t_{d(BCLK-WR)}$	WR signal output delay time			25	ns
$t_{h(BCLK-WR)}$	WR signal output hold time		0		ns
$t_{d(BCLK-DB)}$	Data output delay time (in relation to BCLK)			40	ns
$t_{h(BCLK-DB)}$	Data output hold time (in relation to BCLK)		0		ns
$t_{d(DB-WR)}$	Data output delay time (in relation to WR)		(Note 2)		ns
$t_{h(WR-DB)}$	Data output hold time (in relation to WR)		(Note 1)		ns
$t_{d(BCLK-ALE)}$	ALE signal output delay time (in relation to BCLK)			15	ns
$t_{h(BCLK-ALE)}$	ALE signal output hold time (in relation to BCLK)		-4		ns
$t_{d(AD-ALE)}$	ALE signal output delay time (in relation to Address)		(Note 3)		ns
$t_{h(AD-ALE)}$	ALE signal output hold time (in relation to Address)		(Note 4)		ns
$t_{d(AD-RD)}$	RD signal output delay from the end of address		0		ns
$t_{d(AD-WR)}$	WR signal output delay from the end of address	0		ns	
$t_{dz(RD-AD)}$	Address output floating start time		8	ns	

Notes:

1. Calculated according to the BCLK frequency as follows:

$$\frac{0.5 \times 10^9}{f_{(BCLK)}} - 10 [ns]$$

2. Calculated according to the BCLK frequency as follows:

$$\frac{(n - 0.5) \times 10^9}{f_{(BCLK)}} - 40 [ns] \quad n \text{ is 2 for 2-wait setting, 3 for 3-wait setting.}$$

3. Calculated according to the BCLK frequency as follows:

$$\frac{0.5 \times 10^9}{f_{(BCLK)}} - 25 [ns]$$

4. Calculated according to the BCLK frequency as follows:

$$\frac{0.5 \times 10^9}{f_{(BCLK)}} - 15 [ns]$$

5. When using multiplex bus, set $f_{(BCLK)}$ 12.5 MHz or less.

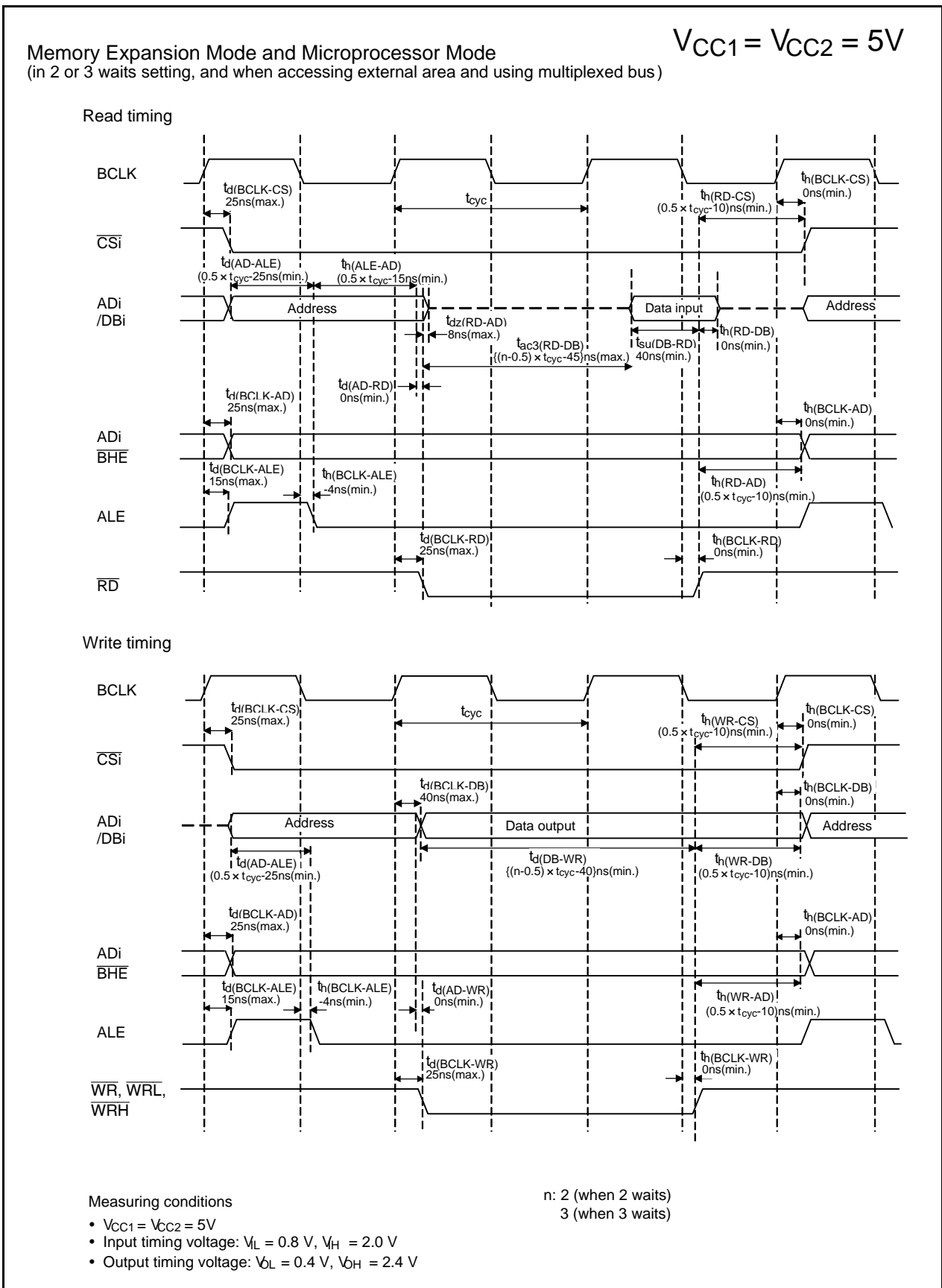

Figure 5.18 Timing Diagram

$$V_{CC1} = V_{CC2} = 5 \text{ V}$$

Switching Characteristics

($V_{CC1} = V_{CC2} = 5 \text{ V}$, $V_{SS} = 0 \text{ V}$, at $T_{opr} = -20^\circ\text{C}$ to $85^\circ\text{C}/-40^\circ\text{C}$ to 85°C unless otherwise specified)

5.2.4.4 In Wait State Setting $2\phi + 3\phi$, $2\phi + 4\phi$, $3\phi + 4\phi$, and $4\phi + 5\phi$, and When Accessing External Area

Table 5.39 Memory Expansion Mode and Microprocessor Mode (in Wait State Setting $2\phi + 3\phi$, $2\phi + 4\phi$, $3\phi + 4\phi$, and $4\phi + 5\phi$, and When Accessing External Area)

Symbol	Parameter	Measuring Condition	Standard		Unit
			Min.	Max.	
$t_{d(BCLK-AD)}$	Address output delay time	See Figure 5.15		25	ns
$t_{h(BCLK-AD)}$	Address output hold time (in relation to BCLK)		0		ns
$t_{h(RD-AD)}$	Address output hold time (in relation to RD)		0		ns
$t_{h(WR-AD)}$	Address output hold time (in relation to WR)		(Note 2)		ns
$t_{d(BCLK-CS)}$	Chip select output delay time			25	ns
$t_{h(BCLK-CS)}$	Chip select output hold time (in relation to BCLK)		0		ns
$t_{d(BCLK-ALE)}$	ALE signal output delay time			15	ns
$t_{h(BCLK-ALE)}$	ALE signal output hold time		-4		ns
$t_{d(BCLK-RD)}$	RD signal output delay time			25	ns
$t_{h(BCLK-RD)}$	RD signal output hold time		0		ns
$t_{d(BCLK-WR)}$	WR signal output delay time			25	ns
$t_{h(BCLK-WR)}$	WR signal output hold time		0		ns
$t_{d(BCLK-DB)}$	Data output delay time (in relation to BCLK)			40	ns
$t_{h(BCLK-DB)}$	Data output hold time (in relation to BCLK) ⁽³⁾		0		ns
$t_{d(DB-WR)}$	Data output delay time (in relation to WR)		(Note 1)		ns
$t_{h(WR-DB)}$	Data output hold time (in relation to WR) ⁽³⁾		(Note 2)		ns

Notes:

1. Calculated according to the BCLK frequency as follows:

$$\frac{(n-0.5) \times 10^9}{f_{(BCLK)}} - 40 [ns] \quad n \text{ is } 3 \text{ for } 2\phi + 3\phi, 4 \text{ for } 2\phi + 4\phi, 4 \text{ for } 3\phi + 4\phi, \text{ and } 5 \text{ for } 4\phi + 5\phi.$$

2. Calculated according to the BCLK frequency as follows:

$$\frac{0.5 \times 10^9}{f_{(BCLK)}} - 10 [ns]$$

3. This standard value shows the timing when the output is off, and does not show hold time of data bus. Hold time of data bus varies with capacitor volume and pull-up (pull-down) resistance value.

Hold time of data bus is expressed in

$$t = -CR \times \ln(1 - V_{OL}/V_{CC2})$$

by a circuit of the right figure.

For example, when $V_{OL} = 0.2V_{CC2}$, $C = 30 \text{ pF}$, $R = 1 \text{ k}\Omega$, hold time of output low level is

$$t = -30 \text{ pF} \times 1 \text{ k}\Omega \times \ln(1 - 0.2V_{CC2}/V_{CC2}) = 6.7 \text{ ns}.$$

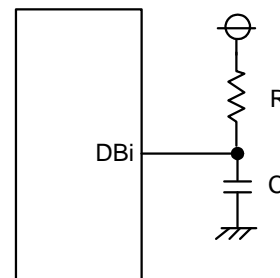

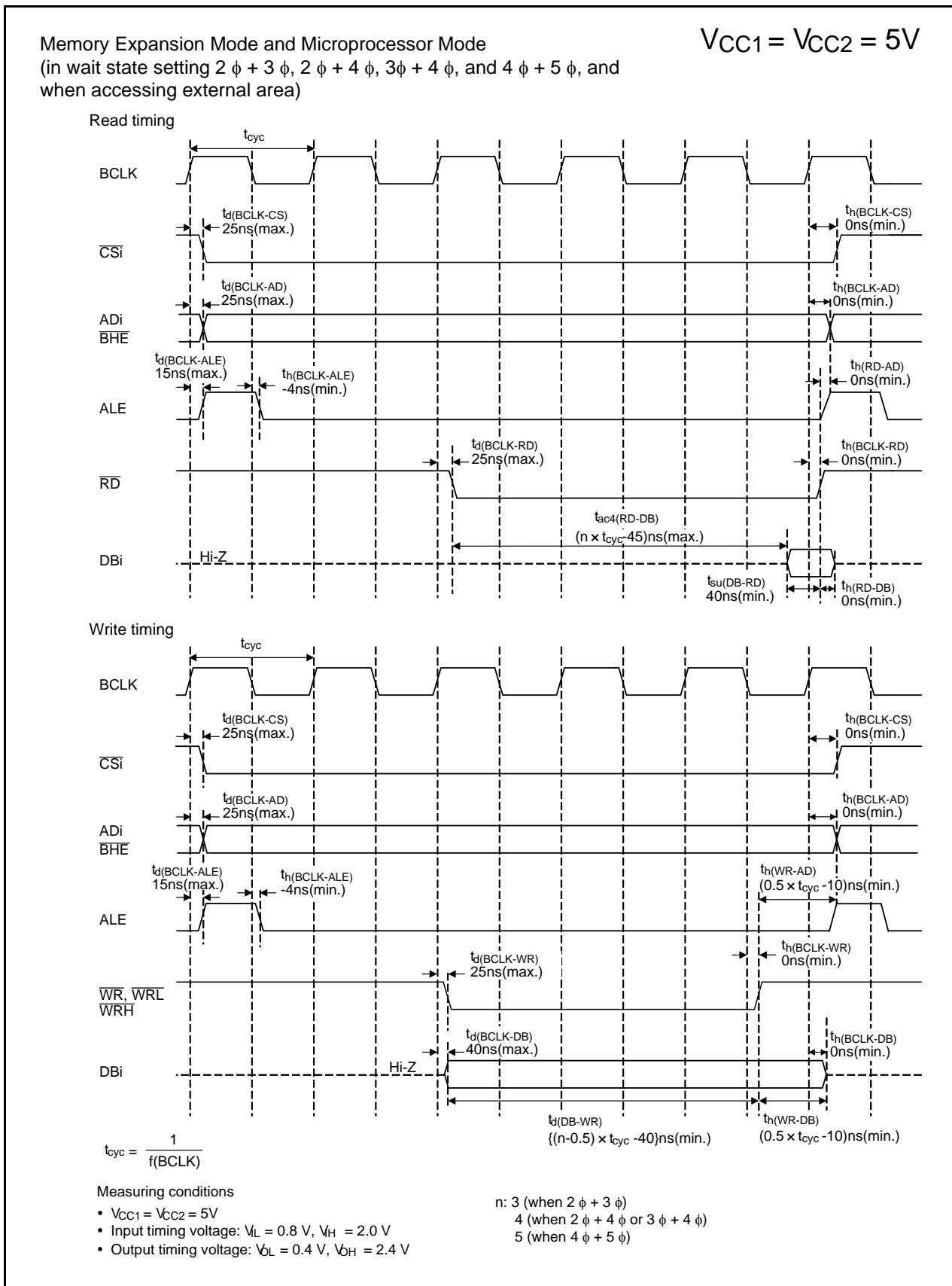

Figure 5.19 Timing Diagram

$$V_{CC1} = V_{CC2} = 5 \text{ V}$$

Switching Characteristics

($V_{CC1} = V_{CC2} = 5 \text{ V}$, $V_{SS} = 0 \text{ V}$, at $T_{opr} = -20^\circ\text{C}$ to $85^\circ\text{C}/-40^\circ\text{C}$ to 85°C unless otherwise specified)

5.2.4.5 In Wait State Setting $2\phi + 3\phi$, $2\phi + 4\phi$, $3\phi + 4\phi$, and $4\phi + 5\phi$, and When Inserting 1 to 3 Recovery Cycles and Accessing External Area

Table 5.40 Memory Expansion and Microprocessor Modes (in Wait State Setting $2\phi + 3\phi$, $2\phi + 4\phi$, $3\phi + 4\phi$, and $4\phi + 5\phi$, and When Inserting 1 to 3 Recovery Cycles and Accessing External Area)

Symbol	Parameter	Measuring Condition	Standard		Unit
			Min.	Max.	
$t_{d(BCLK-AD)}$	Address output delay time	See Figure 5.15		25	ns
$t_{h(BCLK-AD)}$	Address output hold time (in relation to BCLK)		0		ns
$t_{h(RD-AD)}$	Address output hold time (in relation to RD)		(Note 4)		ns
$t_{h(WR-AD)}$	Address output hold time (in relation to WR)		(Note 2)		ns
$t_{d(BCLK-CS)}$	Chip select output delay time			25	ns
$t_{h(BCLK-CS)}$	Chip select output hold time (in relation to BCLK)		0		ns
$t_{d(BCLK-ALE)}$	ALE signal output delay time			15	ns
$t_{h(BCLK-ALE)}$	ALE signal output hold time		-4		ns
$t_{d(BCLK-RD)}$	RD signal output delay time			25	ns
$t_{h(BCLK-RD)}$	RD signal output hold time		0		ns
$t_{d(BCLK-WR)}$	WR signal output delay time			25	ns
$t_{h(BCLK-WR)}$	WR signal output hold time		0		ns
$t_{d(BCLK-DB)}$	Data output delay time (in relation to BCLK)			40	ns
$t_{h(BCLK-DB)}$	Data output hold time (in relation to BCLK) ⁽³⁾		0		ns
$t_{d(DB-WR)}$	Data output delay time (in relation to WR)		(Note 1)		ns
$t_{h(WR-DB)}$	Data output hold time (in relation to WR) ⁽³⁾		(Note 2)		ns

Notes:

1. Calculated according to the BCLK frequency as follows:

$$\frac{n \times 10^9}{f_{(BCLK)}} - 40 [ns] \quad n \text{ is 3 for } 2\phi + 3\phi, 4 \text{ for } 2\phi + 4\phi, 4 \text{ for } 3\phi + 4\phi, \text{ and } 5 \text{ for } 4\phi + 5\phi.$$

2. Calculated according to the BCLK frequency as follows:

$$\frac{m \times 10^9}{f_{(BCLK)}} - 10 [ns] \quad m \text{ is 1 when 1 recovery cycle is inserted, 2 when 2 recovery cycles are inserted, and 3 when 3 recovery cycles are inserted.}$$

3. This standard value shows the timing when the output is off, and does not show hold time of data bus.

Hold time of data bus varies with capacitor volume and pull-up (pull-down) resistance value.

Hold time of data bus is expressed in

$$t = -CR \times \ln(1 - V_{OL}/V_{CC2})$$

by a circuit of the right figure.

For example, when $V_{OL} = 0.2V_{CC2}$, $C = 30 \text{ pF}$, $R = 1 \text{ k}\Omega$, hold time of output low level is

$$t = -30 \text{ pF} \times 1 \text{ k}\Omega \times \ln(1 - 0.2V_{CC2}/V_{CC2}) = 6.7 \text{ ns.}$$

4. Calculated according to the BCLK frequency as follows:

$$\frac{m \times 10^9}{f_{(BCLK)}} + 0 [ns] \quad m \text{ is 1 when 1 recovery cycle is inserted, 2 when 2 recovery cycles are inserted, and 3 when 3 recovery cycles are inserted.}$$

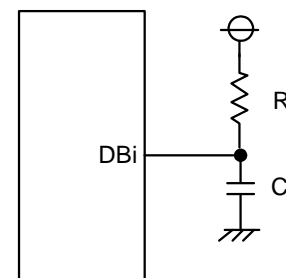

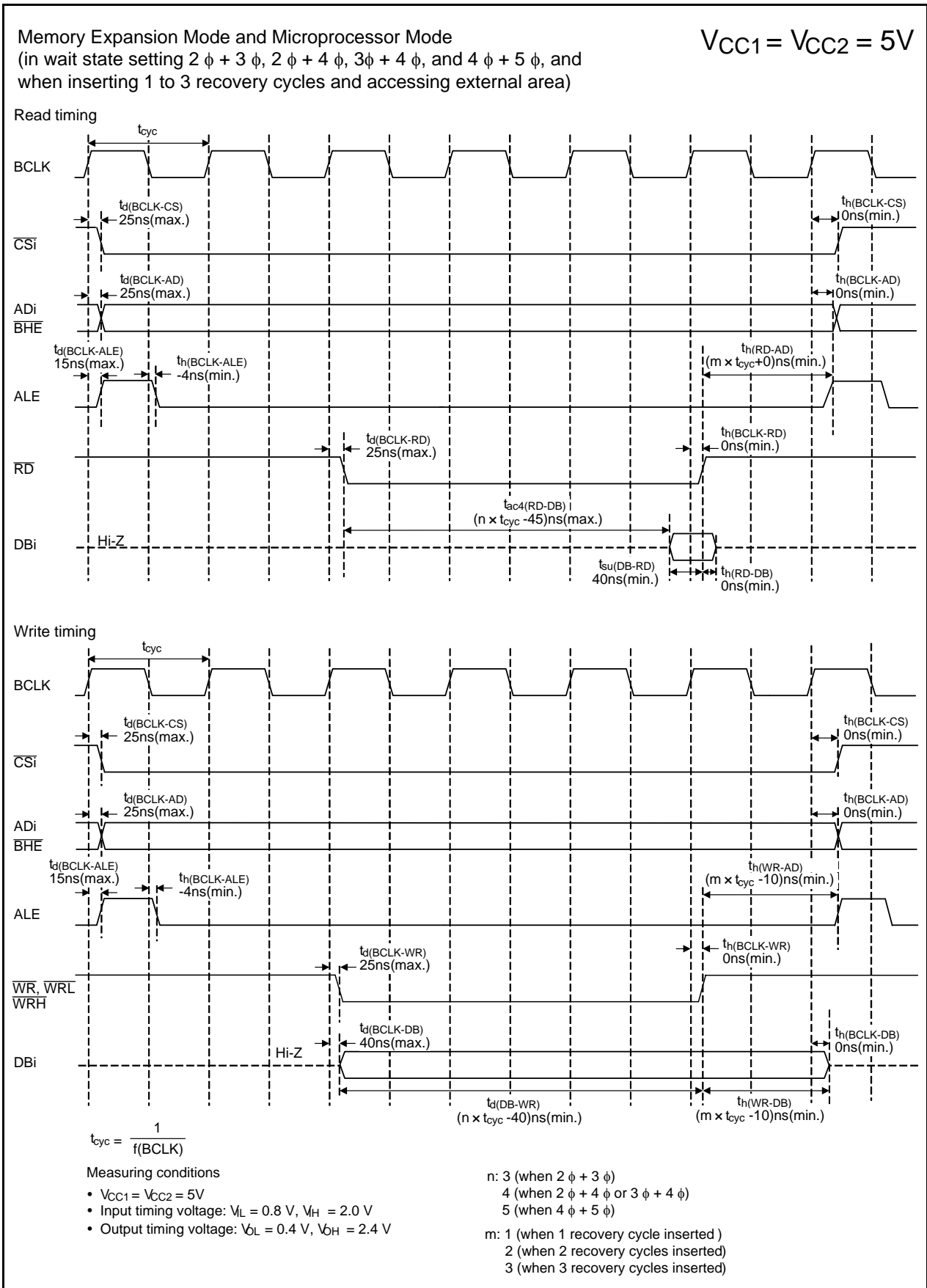

Figure 5.20 Timing Diagram

5.3 Electrical Characteristics ($V_{CC1} = V_{CC2} = 3\text{ V}$)

5.3.1 Electrical Characteristics

$$V_{CC1} = V_{CC2} = 3\text{ V}$$

Table 5.41 Electrical Characteristics (1) (1)

$V_{CC1} = V_{CC2} = 2.7$ to 3.3 V , $V_{SS} = 0\text{ V}$ at $T_{opr} = -20^\circ\text{C}$ to $85^\circ\text{C}/-40^\circ\text{C}$ to 85°C , $f_{(BCLK)} = 20\text{ MHz}$ unless otherwise specified.

Symbol	Parameter		Measuring Condition	Standard			Unit	
				Min.	Typ.	Max.		
V_{OH}	High output voltage	P6_0 to P6_7, P7_2 to P7_7, P8_0 to P8_4, P8_6, P8_7, P9_0 to P9_7, P10_0 to P10_7	$I_{OH} = -1\text{ mA}$	$V_{CC1} - 0.5$		V_{CC1}	V	
		P0_0 to P0_7, P1_0 to P1_7, P2_0 to P2_7, P3_0 to P3_7, P4_0 to P4_7, P5_0 to P5_7	$I_{OH} = -1\text{ mA}$	$V_{CC2} - 0.5$		V_{CC2}		
V_{OH}	High output voltage	XOUT	HIGHPOWER	$I_{OH} = -0.1\text{ mA}$	$V_{CC1} - 0.5$		V_{CC1}	V
			LOWPOWER	$I_{OH} = -50\text{ }\mu\text{A}$	$V_{CC1} - 0.5$		V_{CC1}	
	High output voltage	XCOUT		With no load applied		1.5		V
V_{OL}	Low output voltage	P6_0 to P6_7, P7_0 to P7_7, P8_0 to P8_7, P9_0 to P9_7, P10_0 to P10_7	$I_{OL} = 1\text{ mA}$			0.5	V	
		P0_0 to P0_7, P1_0 to P1_7, P2_0 to P2_7, P3_0 to P3_7, P4_0 to P4_7, P5_0 to P5_7	$I_{OL} = 1\text{ mA}$			0.5		
		CEC	$I_{OL} = 1\text{ mA}$		0	0.5	V	
V_{OL}	Low output voltage	XOUT	HIGHPOWER	$I_{OL} = 0.1\text{ mA}$		0.5	V	
			LOWPOWER	$I_{OL} = 50\text{ }\mu\text{A}$		0.5		
	Low output voltage	XCOUT		With no load applied		0		V
$V_{T+}-V_{T-}$	Hysteresis	HOLD, RDY, TA0IN to TA4IN, TB0IN to TB5IN, INT0 to INT7, NMI, ADTRG, CTS0 to CTS2, CTS5 to CTS7, SCL0 to SCL2, SCL5 to SCL7, SDA0 to SDA2, SDA5 to SDA7, CLK0 to CLK7, TA0OUT to TA4OUT, KI0 to KI7, RXD0 to RXD2, RXD5 to RXD7, SIN3, SIN4, SD, PMC0, PMC1, SCLMM, SDAMM, ZP, IDU, IDV, IDW		0.2		1.0	V	
		CEC		0.2	0.5	1.0		V
		RESET		0.2		1.8		V
I_{IH}	High input current	P0_0 to P0_7, P1_0 to P1_7, P2_0 to P2_7, P3_0 to P3_7, P4_0 to P4_7, P5_0 to P5_7, P6_0 to P6_7, P7_0 to P7_7, P8_0 to P8_7, P9_0 to P9_7, P10_0 to P10_7 XIN, RESET, CNVSS, BYTE	$V_I = 3\text{ V}$			4.0	μA	
–	Leakage current in powered-off state	CEC	$V_{CC1} = 0\text{ V}$			1.8	μA	
I_{IL}	Low input current	P0_0 to P0_7, P1_0 to P1_7, P2_0 to P2_7, P3_0 to P3_7, P4_0 to P4_7, P5_0 to P5_7, P6_0 to P6_7, P7_0 to P7_7, P8_0 to P8_7, P9_0 to P9_7, P10_0 to P10_7 XIN, RESET, CNVSS, BYTE	$V_I = 0\text{ V}$			-4.0	μA	
R_{PULLUP}	Pull-up resistance	P0_0 to P0_7, P1_0 to P1_7, P2_0 to P2_7, P3_0 to P3_7, P4_0 to P4_7, P5_0 to P5_7, P6_0 to P6_7, P7_2 to P7_7, P8_0 to P8_4, P8_6, P8_7, P9_0 to P9_7, P10_0 to P10_7	$V_I = 0\text{ V}$	50	100	500	$\text{k}\Omega$	
R_{fXIN}	Feedback resistance	XIN			0.8		$\text{M}\Omega$	
R_{fXCIN}	Feedback resistance	XCIN			8		$\text{M}\Omega$	
V_{RAM}	RAM retention voltage		In stop mode	1.8			V	

Note:

- When $V_{CC1} \neq V_{CC2}$, refer to 5 V, 3 V, or 1.8 V standard depending on the voltage.

$$V_{CC1} = V_{CC2} = 3 \text{ V}$$

Table 5.42 Electrical Characteristics (2)
 $V_{CC1} = V_{CC2} = 2.7 \text{ to } 3.3 \text{ V}$, $V_{SS} = 0 \text{ V}$ at $T_{opr} = -20^\circ\text{C}$ to $85^\circ\text{C}/-40^\circ\text{C}$ to 85°C , $f_{(BCLK)} = 20 \text{ MHz}$ unless otherwise specified.

Symbol	Parameter	Measuring Condition	Standard			Unit	
			Min.	Typ.	Max.		
I_{CC}	Power supply current In single-chip, mode, the output pin are open and other pins are V_{SS}	High-speed mode	$f_{(BCLK)} = 20 \text{ MHz}$ (no division) XIN = 20 MHz (square wave) 125 kHz on-chip oscillator stopped CM15 = 1 (drive capacity High) A/D converter stopped		9.5		mA
			$f_{(BCLK)} = 20 \text{ MHz}$ (no division) XIN = 20 MHz (square wave) 125 kHz on-chip oscillator stopped CM15 = 1 (drive capacity High) A/D converter operating ⁽²⁾		10.2		mA
			$f_{(BCLK)} = 20 \text{ MHz}$ XIN = 20 MHz (square wave) 125 kHz on-chip oscillator stopped CM15 = 0 (drive capacity Low) A/D converter stopped		9.2		mA
			$f_{(BCLK)} = 20 \text{ MHz}$ (no division) XIN = 20 MHz (square wave) 125 kHz on-chip oscillator stopped CM15 = 1 (drive capacity High) PCLKSTP1 = FF (peripheral clock stopped)		7.9		mA
			$f_{(BCLK)} = 20 \text{ MHz}$ (no division) XIN = 20 MHz (square wave) 125 kHz on-chip oscillator stopped CM15 = 0 (drive capacity Low) PCLKSTP1 = FF (peripheral clock stopped)		7.6		mA
		40 MHz on-chip oscillator mode	Main clock stopped 40 MHz on-chip oscillator on, divide-by-2 ($f_{(BCLK)} = 20 \text{ MHz}$) 125 kHz on-chip oscillator stopped		9.0		mA
		125 kHz on-chip oscillator mode	Main clock stopped 40 MHz on-chip oscillator stopped 125 kHz on-chip oscillator on, no division FMR22 = 1 (slow read mode)		450.0		μA
		Low-power mode	$f_{(BCLK)} = 32 \text{ MHz}$ FMR 22 = FMR23 = 1 (in low-current consumption read mode) On flash memory ⁽¹⁾		80.0		μA
		Wait mode	$f_{(BCLK)} = 32 \text{ kHz}$ Main clock stopped 40 MHz on-chip oscillator stopped 125 kHz on-chip oscillator on PM25 = 1 (peripheral function clock fC operating) $T_{opr} = 25^\circ\text{C}$ Real-time clock operating		5.3		μA
			$f_{(BCLK)} = 32 \text{ MHz}$ 40 MHz on-chip oscillator stopped 125 kHz on-chip oscillator stopped PM25 = 0 (peripheral function clock fC stopped) $T_{opr} = 25^\circ\text{C}$		5.0		μA
		Stop mode	$T_{opr} = 25^\circ\text{C}$		2.2		μA
		During flash memory program	$f_{(BCLK)} = 10 \text{ MHz}$, PM17 = 1 (one wait) $V_{CC1} = 3.0 \text{ V}$		20.0		mA
During flash memory erase	$f_{(BCLK)} = 10 \text{ MHz}$, PM17 = 1 (one wait) $V_{CC1} = 3.0 \text{ V}$		30.0		mA		

Notes:

- This indicates the memory in which the program to be executed exists.
- A/D conversion is executed in repeat mode.

$$V_{CC1} = V_{CC2} = 3 \text{ V}$$

5.3.2 Timing Requirements (Peripheral Functions and Others)

($V_{CC1} = V_{CC2} = 3 \text{ V}$, $V_{SS} = 0 \text{ V}$, at $T_{opr} = -20^{\circ}\text{C}$ to $85^{\circ}\text{C}/-40^{\circ}\text{C}$ to 85°C unless otherwise specified)

5.3.2.1 Reset Input ($\overline{\text{RESET}}$ Input)

Table 5.43 Reset Input ($\overline{\text{RESET}}$ Input)

Symbol	Parameter	Standard		Unit
		Min.	Max.	
$t_{w(\text{RSTL})}$	$\overline{\text{RESET}}$ input low pulse width	10		μs

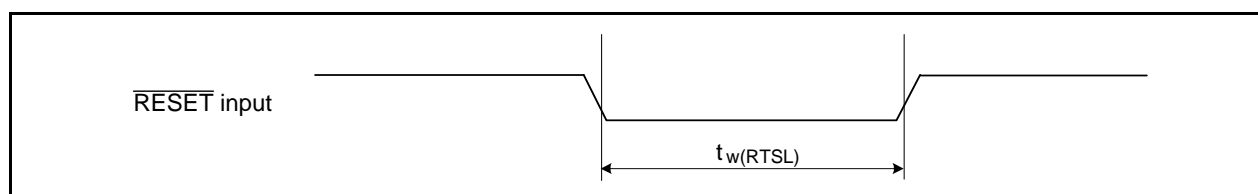

Figure 5.21 Reset Input ($\overline{\text{RESET}}$ Input)

5.3.2.2 External Clock Input

Table 5.44 External Clock Input (XIN Input) (1)

Symbol	Parameter	Standard		Unit
		Min.	Max.	
t_c	External clock input cycle time	50		ns
$t_{w(\text{H})}$	External clock input high pulse width	20		ns
$t_{w(\text{L})}$	External clock input low pulse width	20		ns
t_r	External clock rise time		9	ns
t_f	External clock fall time		9	ns

Note:

1. The condition is $V_{CC1} = V_{CC2} = 2.7$ to 3.0 V .

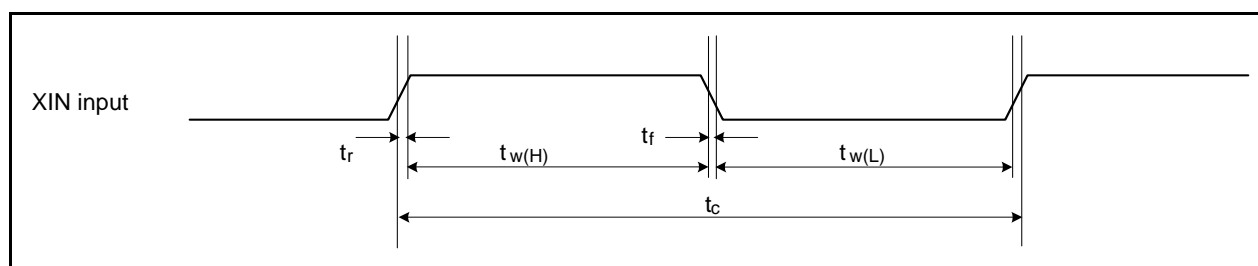

Figure 5.22 External Clock Input (XIN Input)

$$V_{CC1} = V_{CC2} = 3 \text{ V}$$

Timing Requirements

($V_{CC1} = V_{CC2} = 3 \text{ V}$, $V_{SS} = 0 \text{ V}$, at $T_{opr} = -20^\circ\text{C}$ to $85^\circ\text{C}/-40^\circ\text{C}$ to 85°C unless otherwise specified)

5.3.2.3 Timer A Input

Table 5.45 Timer A Input (Counter Input in Event Counter Mode)

Symbol	Parameter	Standard		Unit
		Min.	Max.	
$t_{c(TA)}$	TAiIN input cycle time	150		ns
$t_{w(TAH)}$	TAiIN input high pulse width	60		ns
$t_{w(TAL)}$	TAiIN input low pulse width	60		ns

Table 5.46 Timer A Input (Gating Input in Timer Mode)

Symbol	Parameter	Standard		Unit
		Min.	Max.	
$t_{c(TA)}$	TAiIN input cycle time	600		ns
$t_{w(TAH)}$	TAiIN input high pulse width	300		ns
$t_{w(TAL)}$	TAiIN input low pulse width	300		ns

Table 5.47 Timer A Input (External Trigger Input in One-Shot Timer Mode)

Symbol	Parameter	Standard		Unit
		Min.	Max.	
$t_{c(TA)}$	TAiIN input cycle time	300		ns
$t_{w(TAH)}$	TAiIN input high pulse width	150		ns
$t_{w(TAL)}$	TAiIN input low pulse width	150		ns

Table 5.48 Timer A Input (External Trigger Input in Pulse Width Modulation Mode and Programmable Output Mode)

Symbol	Parameter	Standard		Unit
		Min.	Max.	
$t_{w(TAH)}$	TAiIN input high pulse width	150		ns
$t_{w(TAL)}$	TAiIN input low pulse width	150		ns

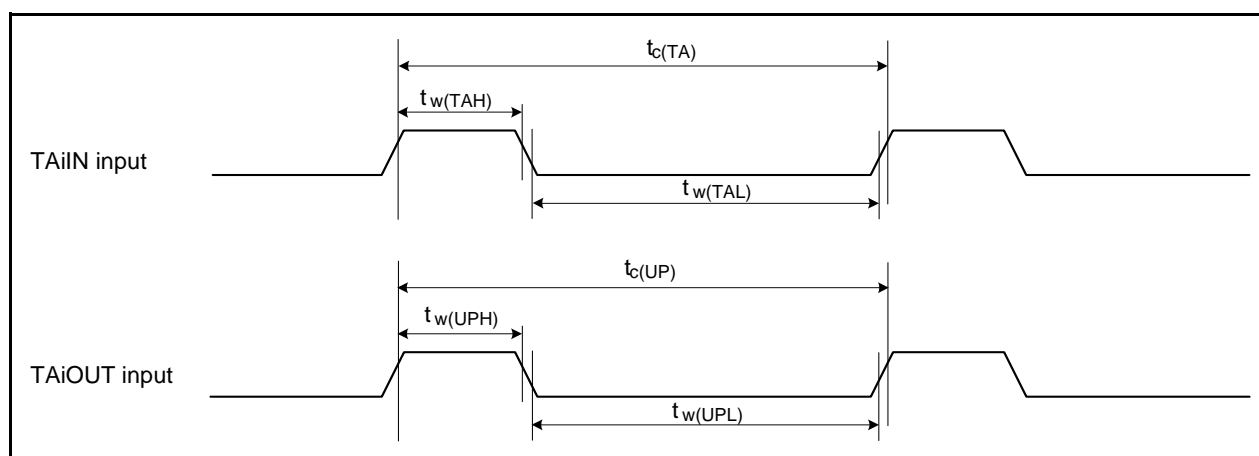

Figure 5.23 Timer A Input

$$V_{CC1} = V_{CC2} = 3 \text{ V}$$

Timing Requirements

($V_{CC1} = V_{CC2} = 3 \text{ V}$, $V_{SS} = 0 \text{ V}$, at $T_{opr} = -20^\circ\text{C}$ to $85^\circ\text{C}/-40^\circ\text{C}$ to 85°C unless otherwise specified)

Table 5.49 Timer A Input (Two-Phase Pulse Input in Event Counter Mode)

Symbol	Parameter	Standard		Unit
		Min.	Max.	
$t_{c(TA)}$	TAiIN input cycle time	2		μs
$t_{su(TAIN-TAOUT)}$	TAiOUT input setup time	500		ns
$t_{su(TAOUT-TAIN)}$	TAiIN input setup time	500		ns

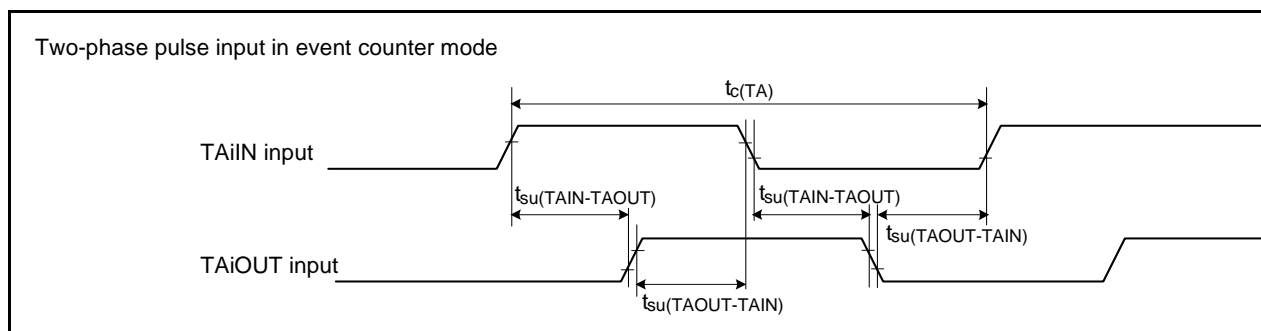
**Figure 5.24 Timer A Input (Two-Phase Pulse Input in Event Counter Mode)**

$$V_{CC1} = V_{CC2} = 3 \text{ V}$$

Timing Requirements

($V_{CC1} = V_{CC2} = 3 \text{ V}$, $V_{SS} = 0 \text{ V}$, at $T_{opr} = -20^\circ\text{C}$ to $85^\circ\text{C}/-40^\circ\text{C}$ to 85°C unless otherwise specified)

5.3.2.4 Timer B Input

Table 5.50 Timer B Input (Counter Input in Event Counter Mode)

Symbol	Parameter	Standard		Unit
		Min.	Max.	
$t_{c(TB)}$	TBiIN input cycle time (counted on one edge)	150		ns
$t_{w(TBH)}$	TBiIN input high pulse width (counted on one edge)	60		ns
$t_{w(TBL)}$	TBiIN input low pulse width (counted on one edge)	60		ns
$t_{c(TB)}$	TBiIN input cycle time (counted on both edges)	300		ns
$t_{w(TBH)}$	TBiIN input high pulse width (counted on both edges)	120		ns
$t_{w(TBL)}$	TBiIN input low pulse width (counted on both edges)	120		ns

Table 5.51 Timer B Input (Pulse Period Measurement Mode)

Symbol	Parameter	Standard		Unit
		Min.	Max.	
$t_{c(TB)}$	TBiIN input cycle time	600		ns
$t_{w(TBH)}$	TBiIN input high pulse width	300		ns
$t_{w(TBL)}$	TBiIN input low pulse width	300		ns

Table 5.52 Timer B Input (Pulse Width Measurement Mode)

Symbol	Parameter	Standard		Unit
		Min.	Max.	
$t_{c(TB)}$	TBiIN input cycle time	600		ns
$t_{w(TBH)}$	TBiIN input high pulse width	300		ns
$t_{w(TBL)}$	TBiIN input low pulse width	300		ns

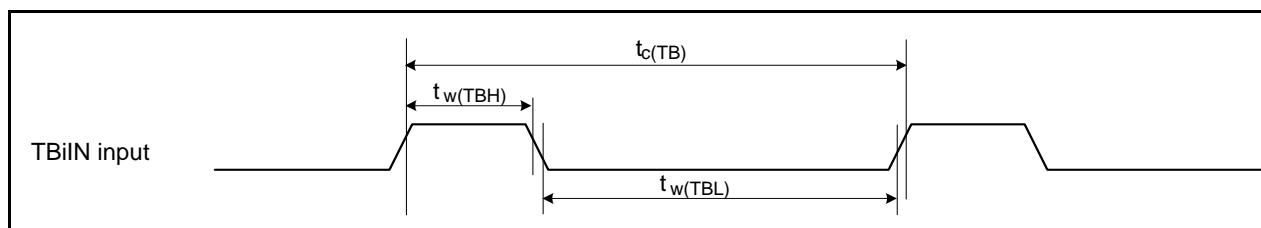

Figure 5.25 Timer B Input

$$V_{CC1} = V_{CC2} = 3\text{ V}$$

Timing Requirements

($V_{CC1} = V_{CC2} = 3\text{ V}$, $V_{SS} = 0\text{ V}$, at $T_{opr} = -20^{\circ}\text{C}$ to 85°C / -40°C to 85°C unless otherwise specified)

5.3.2.5 Serial Interface

Table 5.53 Serial Interface

Symbol	Parameter	Standard		Unit
		Min.	Max.	
$t_{c(CK)}$	CLKi input cycle time	300		ns
$t_{w(CKH)}$	CLKi input high pulse width	150		ns
$t_{w(CKL)}$	CLKi input low pulse width	150		ns
$t_{d(C-Q)}$	TXDi output delay time		160	ns
$t_{h(C-Q)}$	TXDi hold time	0		ns
$t_{su(D-C)}$	RXDi input setup time	100		ns
$t_{h(C-D)}$	RXDi input hold time	90		ns

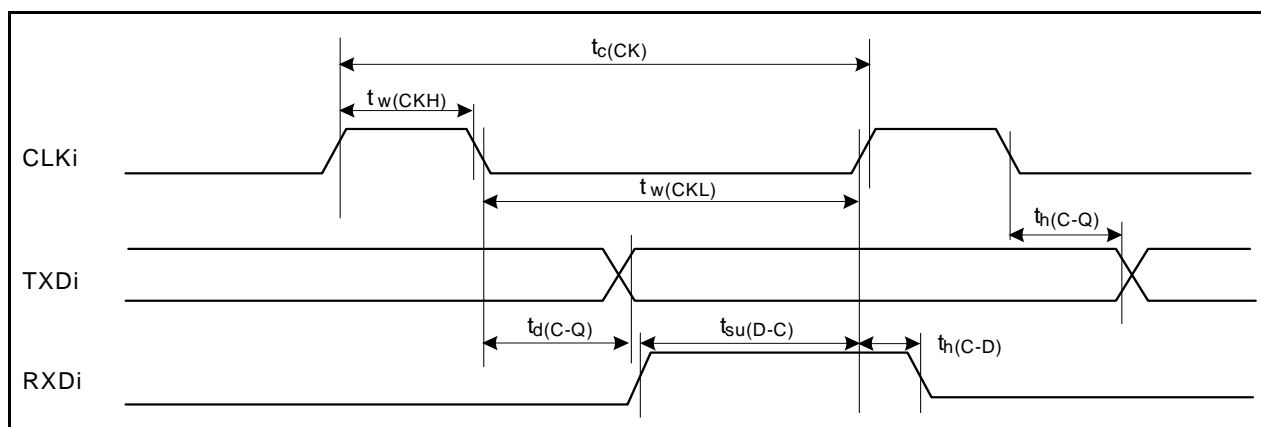

Figure 5.26 Serial Interface

5.3.2.6 External Interrupt \overline{INTi} Input

Table 5.54 External Interrupt \overline{INTi} Input

Symbol	Parameter	Standard		Unit
		Min.	Max.	
$t_{w(INH)}$	\overline{INTi} input high pulse width	380		ns
$t_{w(INL)}$	\overline{INTi} input low pulse width	380		ns

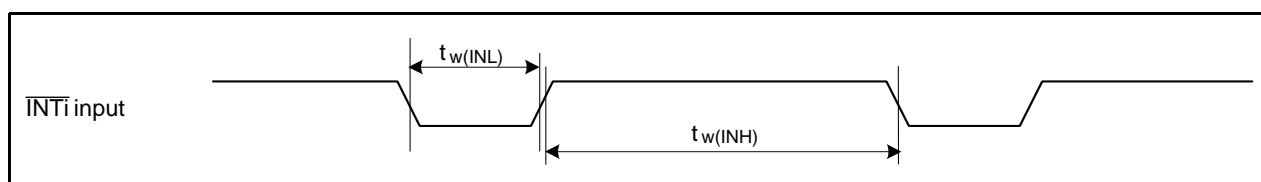

Figure 5.27 External Interrupt \overline{INTi} Input

$$V_{CC1} = V_{CC2} = 3\text{ V}$$

Timing Requirements

($V_{CC1} = V_{CC2} = 3\text{ V}$, $V_{SS} = 0\text{ V}$, at $T_{opr} = -20^{\circ}\text{C}$ to 85°C / -40°C to 85°C unless otherwise specified)

5.3.2.7 Multi-master I²C-bus

Table 5.55 Multi-master I²C-bus

Symbol	Parameter	Standard Clock Mode		Fast-mode		Unit
		Min.	Max.	Min.	Max.	
t_{BUF}	Bus free time	4.7		1.3		μs
$t_{HD;STA}$	Hold time in start condition	4.0		0.6		μs
t_{LOW}	Hold time in SCL clock 0 status	4.7		1.3		μs
t_R	SCL, SDA signals' rising time		1000	$20 + 0.1 C_b$	300	ns
$t_{HD;DAT}$	Data hold time	0		0	0.9	μs
t_{HIGH}	Hold time in SCL clock 1 status	4.0		0.6		μs
t_F	SCL, SDA signals' falling time		300	$20 + 0.1 C_b$	300	ns
$t_{su;DAT}$	Data setup time	250		100		ns
$t_{su;STA}$	Setup time in restart condition	4.7		0.6		μs
$t_{su;STO}$	Stop condition setup time	4.0		0.6		μs

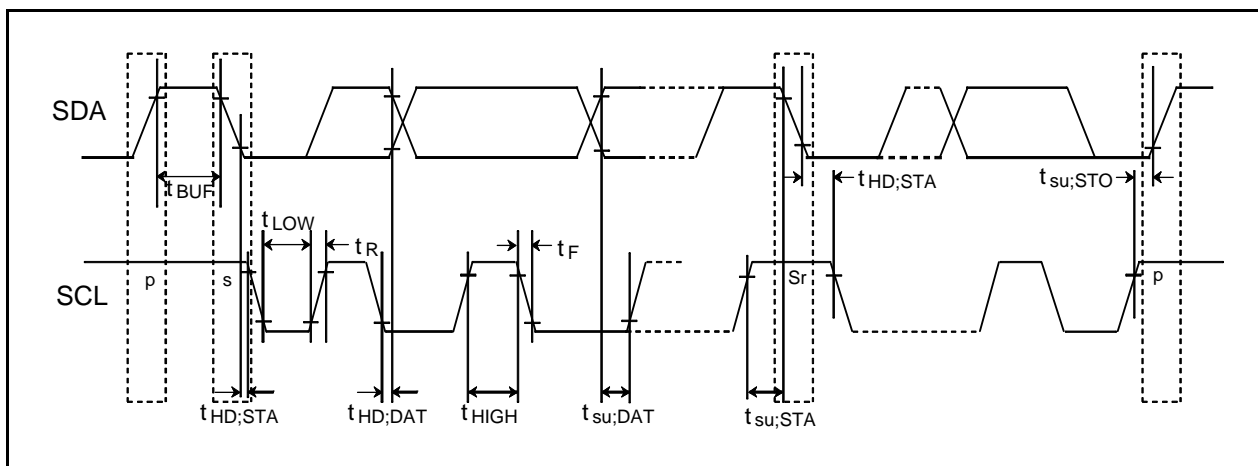

Figure 5.28 Multi-master I²C-bus

$$V_{CC1} = V_{CC2} = 3 \text{ V}$$

Timing Requirements

($V_{CC1} = V_{CC2} = 3 \text{ V}$, $V_{SS} = 0 \text{ V}$, at $T_{opr} = -20^\circ\text{C}$ to $85^\circ\text{C}/-40^\circ\text{C}$ to 85°C unless otherwise specified)

5.3.3 Timing Requirements (Memory Expansion Mode and Microprocessor Mode)

Table 5.56 Memory Expansion Mode and Microprocessor Mode

Symbol	Parameter	Standard		Unit
		Min.	Max.	
$t_{ac1}(\text{RD-DB})$	Data input access time (for setting with no wait)		(Note 1)	ns
$t_{ac2}(\text{RD-DB})$	Data input access time (for setting with wait)		(Note 2)	ns
$t_{ac3}(\text{RD-DB})$	Data input access time (when accessing multiplex bus area)		(Note 3)	ns
$t_{ac4}(\text{RD-DB})$	Data input access time (for setting with 2 ϕ + 3 ϕ or more)		(Note 4)	ns
$t_{su}(\text{DB-RD})$	Data input setup time	50		ns
$t_{su}(\text{RDY-BCLK})$	$\overline{\text{RDY}}$ input setup time	85		ns
$t_h(\text{RD-DB})$	Data input hold time	0		ns
$t_h(\text{BCLK-RDY})$	$\overline{\text{RDY}}$ input hold time	0		ns

Notes:

1. Calculated according to the BCLK frequency as follows:

$$\frac{0.5 \times 10^9}{f_{(BCLK)}} - 60[\text{ns}]$$

2. Calculated according to the BCLK frequency as follows:

$$\frac{(n + 0.5) \times 10^9}{f_{(BCLK)}} - 60[\text{ns}] \quad n \text{ is 1 for 1 wait setting, 2 for 2 waits setting and 3 for 3 waits setting.}$$

3. Calculated according to the BCLK frequency as follows:

$$\frac{(n - 0.5) \times 10^9}{f_{(BCLK)}} - 60[\text{ns}] \quad n \text{ is 2 for 2 waits setting, 3 for 3 waits setting.}$$

4. Calculated according to the BCLK frequency as follows:

$$\frac{n \times 10^9}{f_{(BCLK)}} - 60[\text{ns}] \quad n \text{ is 3 for } 2\phi + 3\phi, 4 \text{ for } 2\phi + 4\phi, 4 \text{ for } 3\phi + 4\phi, 5 \text{ for } 4\phi + 5\phi, .$$

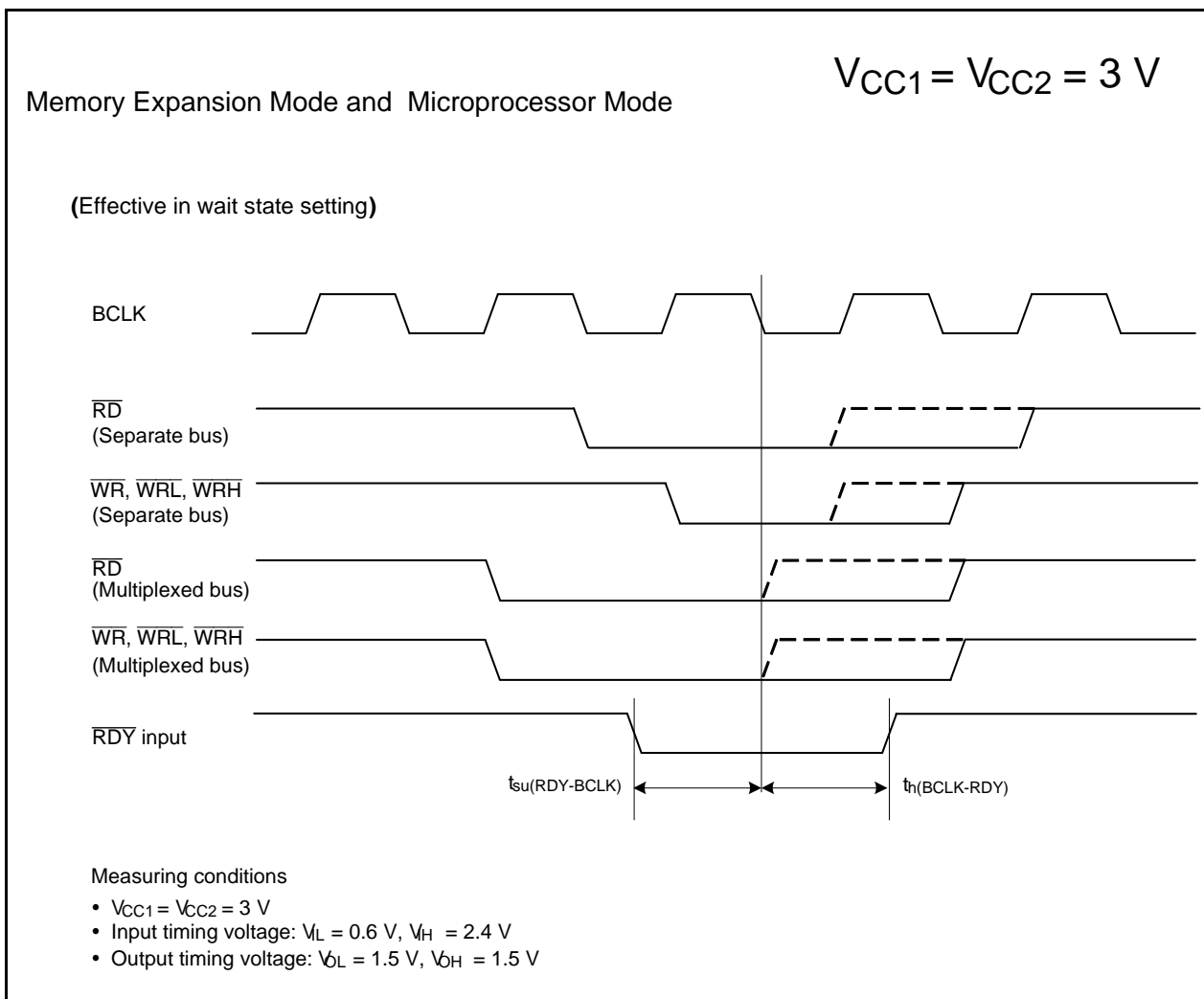

Figure 5.29 Timing Diagram

$$V_{CC1} = V_{CC2} = 3 \text{ V}$$

5.3.4 Switching Characteristics (Memory Expansion Mode and Microprocessor Mode)

($V_{CC1} = V_{CC2} = 3 \text{ V}$, $V_{SS} = 0 \text{ V}$, at $T_{opr} = -20^{\circ}\text{C}$ to $85^{\circ}\text{C}/-40^{\circ}\text{C}$ to 85°C unless otherwise specified)

5.3.4.1 In No Wait State Setting

Table 5.57 Memory Expansion and Microprocessor Modes (in No Wait State Setting)

Symbol	Parameter	Measuring Condition	Standard		Unit
			Min.	Max.	
$t_{d(\text{BCLK-AD})}$	Address output delay time	See Figure 5.30		30	ns
$t_{h(\text{BCLK-AD})}$	Address output hold time (in relation to BCLK)		0		ns
$t_{h(\text{RD-AD})}$	Address output hold time (in relation to RD)		0		ns
$t_{h(\text{WR-AD})}$	Address output hold time (in relation to WR)		(Note 2)		ns
$t_{d(\text{BCLK-CS})}$	Chip select output delay time			30	ns
$t_{h(\text{BCLK-CS})}$	Chip select output hold time (in relation to BCLK)		0		ns
$t_{d(\text{BCLK-ALE})}$	ALE signal output delay time			25	ns
$t_{h(\text{BCLK-ALE})}$	ALE signal output hold time		-4		ns
$t_{d(\text{BCLK-RD})}$	RD signal output delay time			30	ns
$t_{h(\text{BCLK-RD})}$	RD signal output hold time		0		ns
$t_{d(\text{BCLK-WR})}$	WR signal output delay time			30	ns
$t_{h(\text{BCLK-WR})}$	WR signal output hold time		0		ns
$t_{d(\text{BCLK-DB})}$	Data output delay time (in relation to BCLK)			40	ns
$t_{h(\text{BCLK-DB})}$	Data output hold time (in relation to BCLK) ⁽³⁾		0		ns
$t_{d(\text{DB-WR})}$	Data output delay time (in relation to WR)		(Note 1)		ns
$t_{h(\text{WR-DB})}$	Data output hold time (in relation to WR) ⁽³⁾		(Note 2)		ns

Notes:

1. Calculated according to the BCLK frequency as follows:

$$\frac{0.5 \times 10^9}{f_{(\text{BCLK})}} - 40[\text{ns}] \quad f_{(\text{BCLK})} \text{ is } 12.5 \text{ MHz or less.}$$

2. Calculated according to the BCLK frequency as follows:

$$\frac{0.5 \times 10^9}{f_{(\text{BCLK})}} - 10[\text{ns}]$$

3. This standard value shows the timing when the output is off, and does not show hold time of data bus.

Hold time of data bus varies with capacitor volume and pull-up (pull-down) resistance value.

Hold time of data bus is expressed in

$$t = -CR \times \ln(1 - V_{OL}/V_{CC2})$$

by a circuit of the right figure.

For example, when $V_{OL} = 0.2V_{CC2}$, $C = 30 \text{ pF}$, $R = 1 \text{ k}\Omega$,

hold time of output low level is

$$t = -30 \text{ pF} \times 1 \text{ k}\Omega \times \ln(1 - 0.2V_{CC2}/V_{CC2})$$

= 6.7 ns.

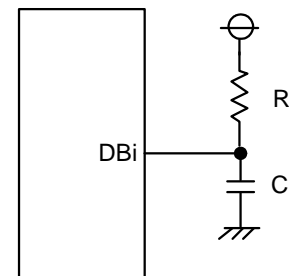

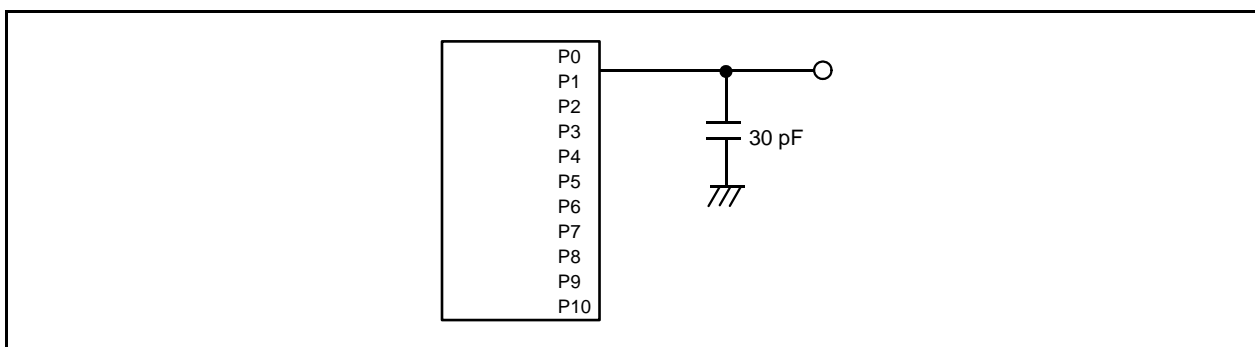

Figure 5.30 Ports P0 to P10 Measurement Circuit

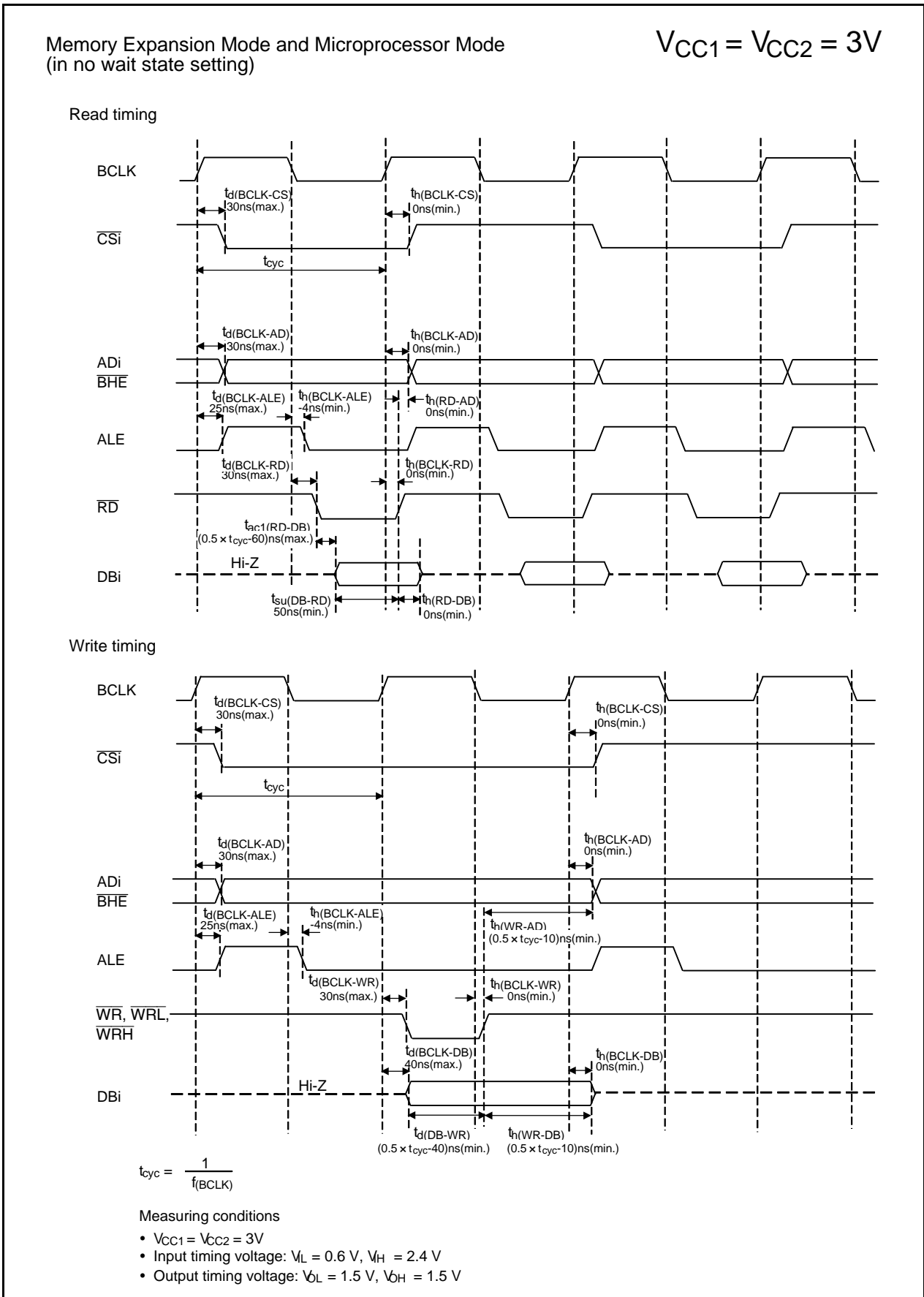

Figure 5.31 Timing Diagram

$$V_{CC1} = V_{CC2} = 3\text{ V}$$

Switching Characteristics

($V_{CC1} = V_{CC2} = 3\text{ V}$, $V_{SS} = 0\text{ V}$, at $T_{opr} = -20^{\circ}\text{C}$ to $85^{\circ}\text{C}/-40^{\circ}\text{C}$ to 85°C unless otherwise specified)

5.3.4.2 In 1 to 3 Waits Setting and When Accessing External Area

Table 5.58 Memory Expansion Mode and Microprocessor Mode (in 1 to 3 Waits Setting and When Accessing External Area)

Symbol	Parameter	Measuring Condition	Standard		Unit
			Min.	Max.	
$t_{d(BCLK-AD)}$	Address output delay time	See Figure 5.30		30	ns
$t_{h(BCLK-AD)}$	Address output hold time (in relation to BCLK)		0		ns
$t_{h(RD-AD)}$	Address output hold time (in relation to RD)		0		ns
$t_{h(WR-AD)}$	Address output hold time (in relation to WR)		(Note 2)		ns
$t_{d(BCLK-CS)}$	Chip select output delay time			30	ns
$t_{h(BCLK-CS)}$	Chip select output hold time (in relation to BCLK)		0		ns
$t_{d(BCLK-ALE)}$	ALE signal output delay time			25	ns
$t_{h(BCLK-ALE)}$	ALE signal output hold time		-4		ns
$t_{d(BCLK-RD)}$	RD signal output delay time			30	ns
$t_{h(BCLK-RD)}$	RD signal output hold time		0		ns
$t_{d(BCLK-WR)}$	WR signal output delay time			30	ns
$t_{h(BCLK-WR)}$	WR signal output hold time		0		ns
$t_{d(BCLK-DB)}$	Data output delay time (in relation to BCLK)			40	ns
$t_{h(BCLK-DB)}$	Data output hold time (in relation to BCLK) ⁽³⁾		0		ns
$t_{d(DB-WR)}$	Data output delay time (in relation to WR)		(Note 1)		ns
$t_{h(WR-DB)}$	Data output hold time (in relation to WR) ⁽³⁾		(Note 2)		ns

Notes:

1. Calculated according to the BCLK frequency as follows:

$$\frac{(n-0.5) \times 10^9}{f_{(BCLK)}} - 40 [ns]$$

n is 1 for 1 wait setting, 2 for 2 waits setting and 3 for 3 waits setting.
When n = 1, $f_{(BCLK)}$ is 12.5 MHz or less.

2. Calculated according to the BCLK frequency as follows:

$$\frac{0.5 \times 10^9}{f_{(BCLK)}} - 10 [ns]$$

3. This standard value shows the timing when the output is off, and does not show hold time of data bus.

Hold time of data bus varies with capacitor volume and pull-up (pull-down) resistance value.

Hold time of data bus is expressed in

$$t = -CR \times \ln(1 - V_{OL}/V_{CC2})$$

by a circuit of the right figure.

For example, when $V_{OL} = 0.2V_{CC2}$, $C = 30\text{ pF}$, $R = 1\text{ k}\Omega$, hold time of output low level is

$$t = -30\text{ pF} \times 1\text{ k}\Omega \times \ln(1 - 0.2V_{CC2}/V_{CC2}) \\ = 6.7\text{ ns.}$$

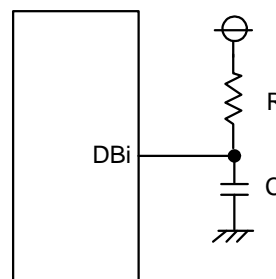

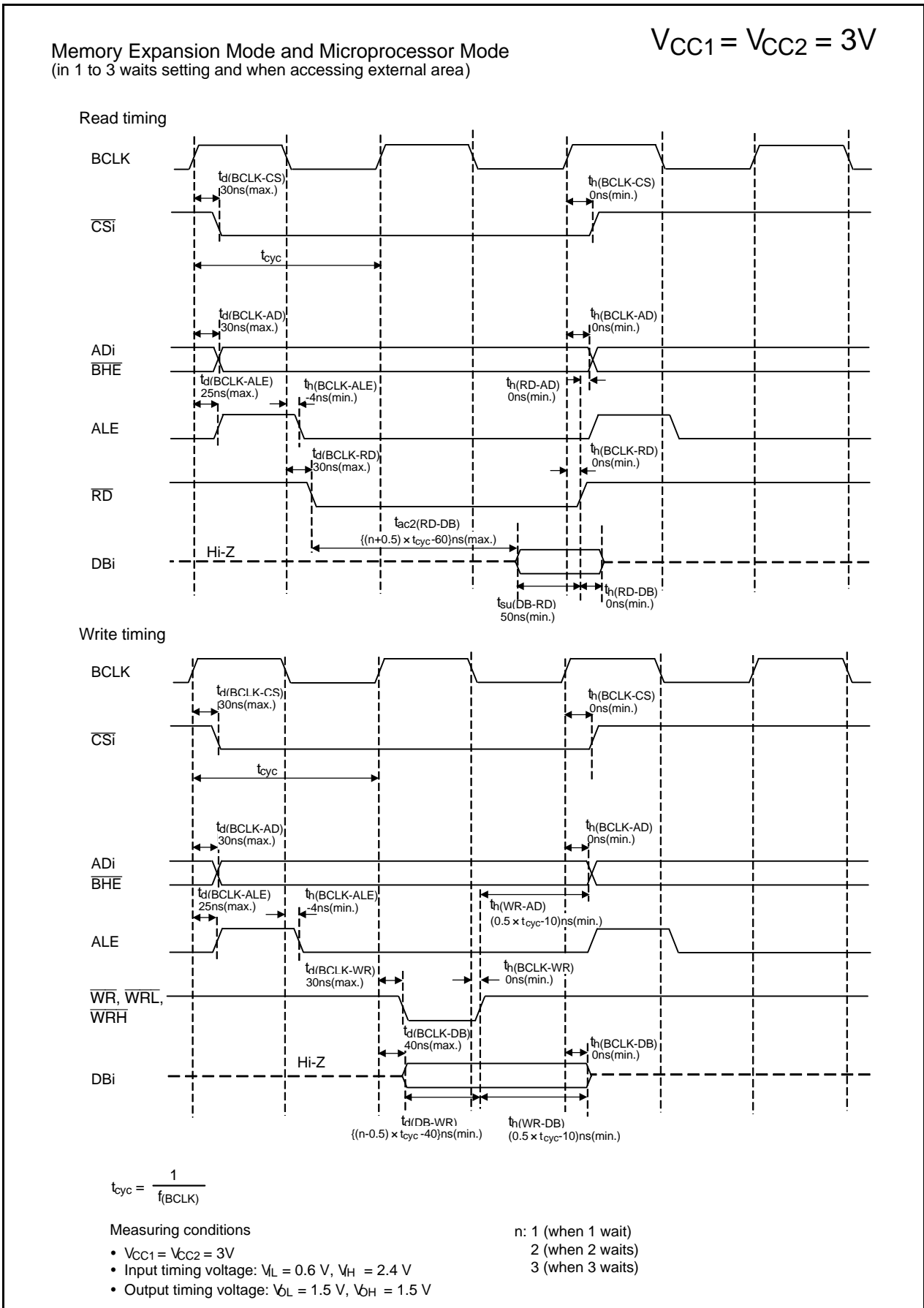

Figure 5.32 Timing Diagram

$$V_{CC1} = V_{CC2} = 3 \text{ V}$$

Switching Characteristics

($V_{CC1} = V_{CC2} = 3 \text{ V}$, $V_{SS} = 0 \text{ V}$, at $T_{opr} = -20^\circ\text{C}$ to $85^\circ\text{C}/-40^\circ\text{C}$ to 85°C unless otherwise specified)

5.3.4.3 In 2 or 3 Waits Setting, and When Accessing External Area and Using Multiplexed Bus

Table 5.59 Memory Expansion Mode and Microprocessor Mode (in 2 or 3 Waits Setting, and When Accessing External Area and Using Multiplexed Bus) (5)

Symbol	Parameter	Measuring Condition	Standard		Unit
			Min.	Max.	
$t_{d(BCLK-AD)}$	Address output delay time	See Figure 5.30		50	ns
$t_{h(BCLK-AD)}$	Address output hold time (in relation to BCLK)		0		ns
$t_{h(RD-AD)}$	Address output hold time (in relation to RD)		(Note 1)		ns
$t_{h(WR-AD)}$	Address output hold time (in relation to WR)		(Note 1)		ns
$t_{d(BCLK-CS)}$	Chip select output delay time			50	ns
$t_{h(BCLK-CS)}$	Chip select output hold time (in relation to BCLK)		0		ns
$t_{h(RD-CS)}$	Chip select output hold time (in relation to RD)		(Note 1)		ns
$t_{h(WR-CS)}$	Chip select output hold time (in relation to WR)		(Note 1)		ns
$t_{d(BCLK-RD)}$	RD signal output delay time			40	ns
$t_{h(BCLK-RD)}$	RD signal output hold time		0		ns
$t_{d(BCLK-WR)}$	WR signal output delay time			40	ns
$t_{h(BCLK-WR)}$	WR signal output hold time		0		ns
$t_{d(BCLK-DB)}$	Data output delay time (in relation to BCLK)			50	ns
$t_{h(BCLK-DB)}$	Data output hold time (in relation to BCLK)		0		ns
$t_{d(DB-WR)}$	Data output delay time (in relation to WR)		(Note 2)		ns
$t_{h(WR-DB)}$	Data output hold time (in relation to WR)		(Note 1)		ns
$t_{d(BCLK-ALE)}$	ALE signal output delay time (in relation to BCLK)			25	ns
$t_{h(BCLK-ALE)}$	ALE signal output hold time (in relation to BCLK)		-4		ns
$t_{d(AD-ALE)}$	ALE signal output delay time (in relation to Address)		(Note 3)		ns
$t_{h(AD-ALE)}$	ALE signal output hold time (in relation to Address)		(Note 4)		ns
$t_{d(AD-RD)}$	RD signal output delay from the end of address	0		ns	
$t_{d(AD-WR)}$	WR signal output delay from the end of address	0		ns	
$t_{dz(RD-AD)}$	Address output floating start time		8	ns	

Notes:

1. Calculated according to the BCLK frequency as follows: $\frac{0.5 \times 10^9}{f_{(BCLK)}} - 10 [ns]$
2. Calculated according to the BCLK frequency as follows:
 $\frac{(n-0.5) \times 10^9}{f_{(BCLK)}} - 50 [ns]$ n is 2 for 2 waits setting, 3 for 3 waits setting.
3. Calculated according to the BCLK frequency as follows: $\frac{0.5 \times 10^9}{f_{(BCLK)}} - 40 [ns]$
4. Calculated according to the BCLK frequency as follows: $\frac{0.5 \times 10^9}{f_{(BCLK)}} - 15 [ns]$
5. When using multiplexed bus, set $f_{(BCLK)}$ 12.5 MHz or less.

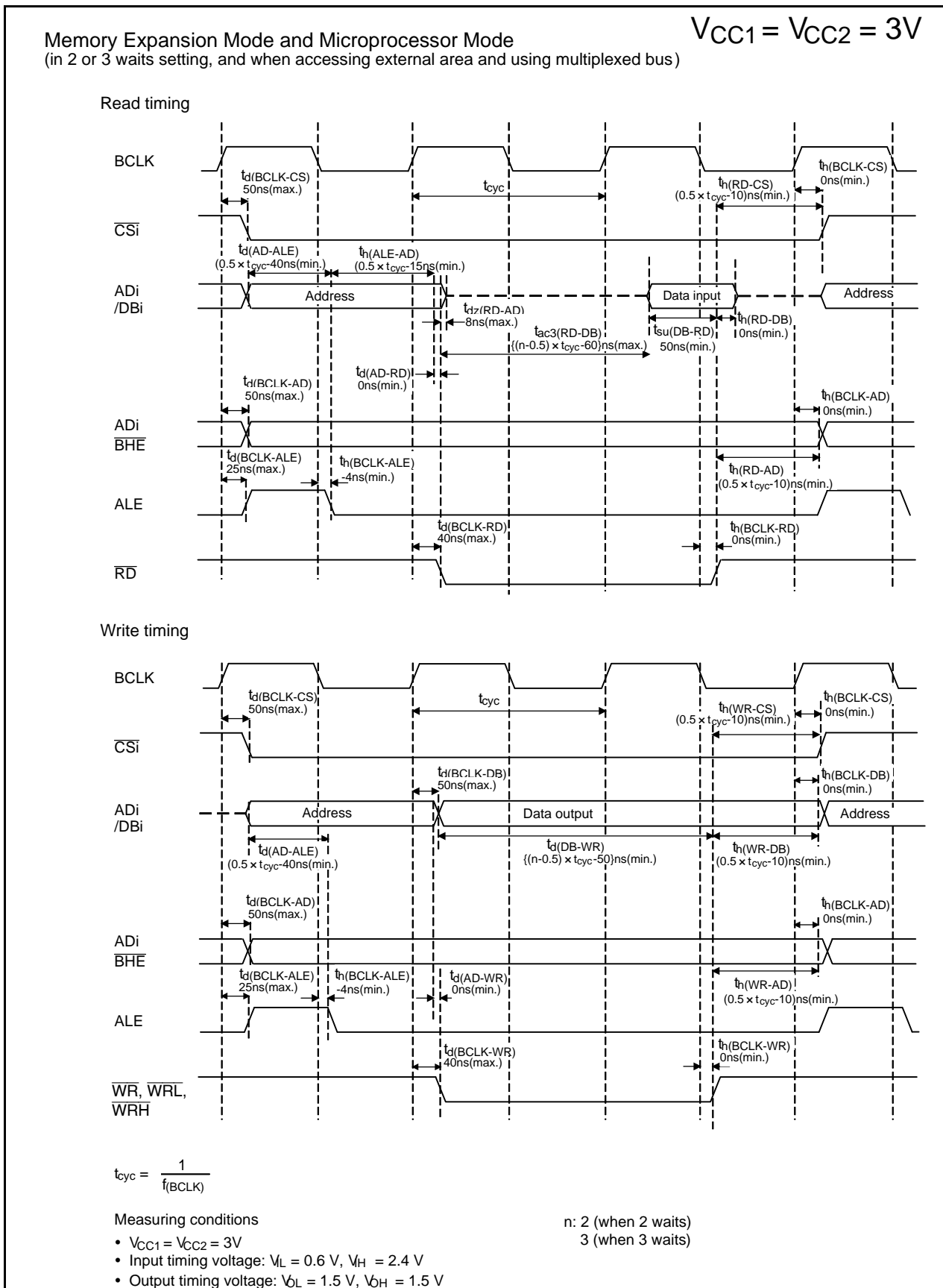

Figure 5.33 Timing Diagram

$$V_{CC1} = V_{CC2} = 3 \text{ V}$$

Switching Characteristics

($V_{CC1} = V_{CC2} = 3 \text{ V}$, $V_{SS} = 0 \text{ V}$, at $T_{opr} = -20^\circ\text{C}$ to $85^\circ\text{C}/-40^\circ\text{C}$ to 85°C unless otherwise specified)

5.3.4.4 In Wait State Setting $2\phi + 3\phi$, $2\phi + 4\phi$, $3\phi + 4\phi$, and $4\phi + 5\phi$, and When Accessing External Area

Table 5.60 Memory Expansion and Microprocessor Modes (in Wait State Setting $2\phi + 3\phi$, $2\phi + 4\phi$, $3\phi + 4\phi$, and $4\phi + 5\phi$, and When Accessing External Area)

Symbol	Parameter	Measuring Condition	Standard		Unit
			Min.	Max.	
$t_{d(BCLK-AD)}$	Address output delay time	See Figure 5.30		30	ns
$t_{h(BCLK-AD)}$	Address output hold time (in relation to BCLK)		0		ns
$t_{h(RD-AD)}$	Address output hold time (in relation to RD)		0		ns
$t_{h(WR-AD)}$	Address output hold time (in relation to WR)		(Note 2)		ns
$t_{d(BCLK-CS)}$	Chip select output delay time			30	ns
$t_{h(BCLK-CS)}$	Chip select output hold time (in relation to BCLK)		0		ns
$t_{d(BCLK-ALE)}$	ALE signal output delay time			25	ns
$t_{h(BCLK-ALE)}$	ALE signal output hold time		-4		ns
$t_{d(BCLK-RD)}$	RD signal output delay time			30	ns
$t_{h(BCLK-RD)}$	RD signal output hold time		0		ns
$t_{d(BCLK-WR)}$	WR signal output delay time			30	ns
$t_{h(BCLK-WR)}$	WR signal output hold time		0		ns
$t_{d(BCLK-DB)}$	Data output delay time (in relation to BCLK)			40	ns
$t_{h(BCLK-DB)}$	Data output hold time (in relation to BCLK) ⁽³⁾		0		ns
$t_{d(DB-WR)}$	Data output delay time (in relation to WR)		(Note 1)		ns
$t_{h(WR-DB)}$	Data output hold time (in relation to WR) ⁽³⁾		(Note 2)		ns

Notes:

1. Calculated according to the BCLK frequency as follows:

$$\frac{(n - 0.5) \times 10^9}{f_{(BCLK)}} - 40 [ns] \quad n \text{ is 3 for } 2\phi + 3\phi, 4 \text{ for } 2\phi + 4\phi, 4 \text{ for } 3\phi + 4\phi, \text{ and 5 for } 4\phi + 5\phi.$$

2. Calculated according to the BCLK frequency as follows:

$$\frac{0.5 \times 10^9}{f_{(BCLK)}} - 10 [ns]$$

3. This standard value shows the timing when the output is off, and does not show hold time of data bus.

Hold time of data bus varies with capacitor volume and pull-up (pull-down) resistance value.

Hold time of data bus is expressed in

$$t = -CR \times \ln(1 - V_{OL}/V_{CC2})$$

by a circuit of the right figure.

For example, when $V_{OL} = 0.2V_{CC2}$, $C = 30 \text{ pF}$, $R = 1 \text{ k}\Omega$,

hold time of output low level is

$$t = -30 \text{ pF} \times 1 \text{ k}\Omega \times \ln(1 - 0.2V_{CC2}/V_{CC2})$$

$$= 6.7 \text{ ns.}$$

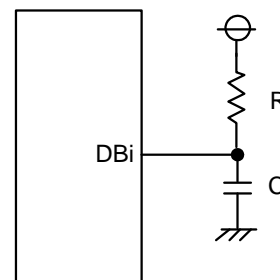

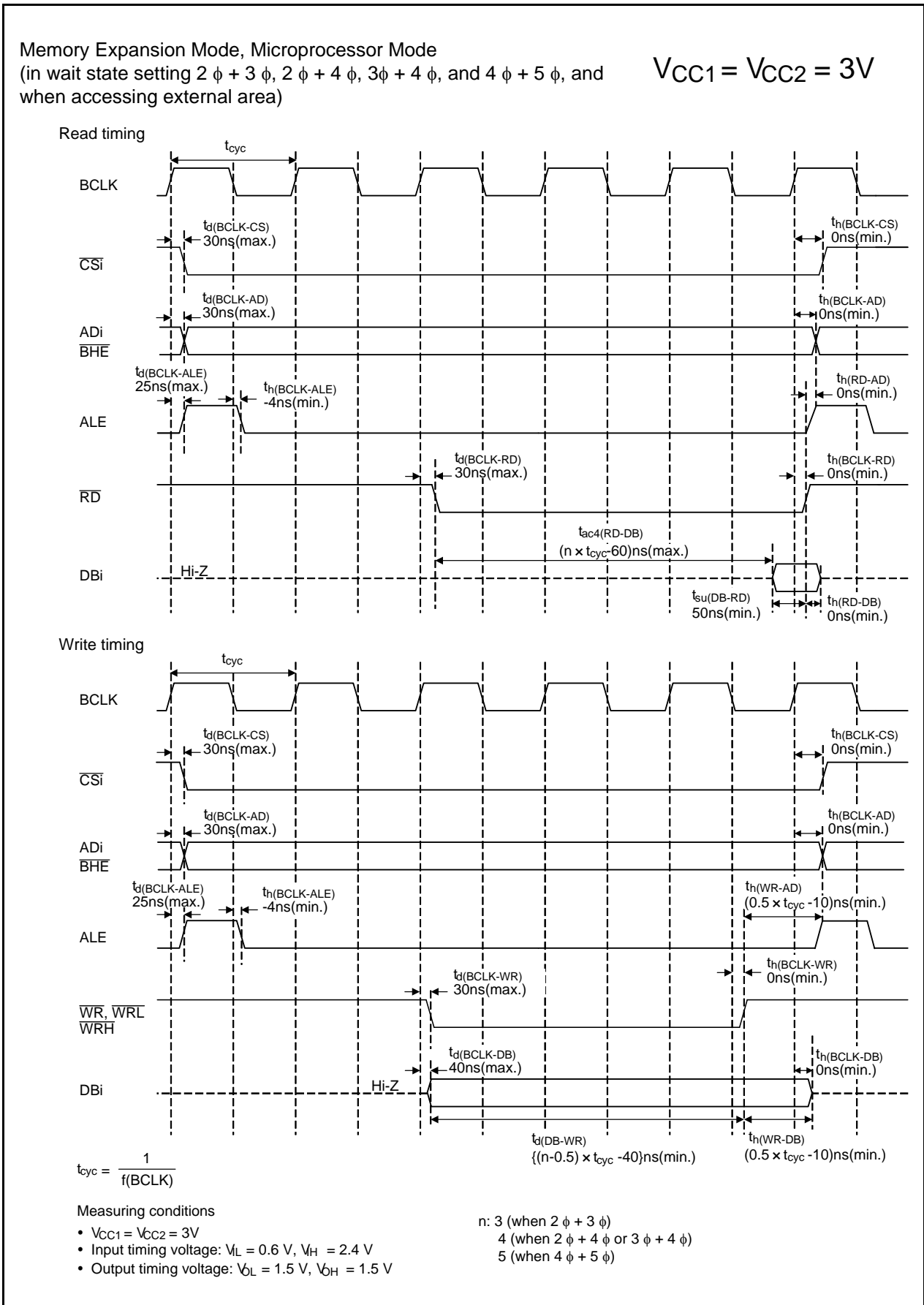

Figure 5.34 Timing Diagram

$$V_{CC1} = V_{CC2} = 3 \text{ V}$$

Switching Characteristics

($V_{CC1} = V_{CC2} = 3 \text{ V}$, $V_{SS} = 0 \text{ V}$, at $T_{opr} = -20^\circ\text{C}$ to $85^\circ\text{C}/-40^\circ\text{C}$ to 85°C unless otherwise specified)

5.3.4.5 In Wait State Setting $2\phi + 3\phi$, $2\phi + 4\phi$, $3\phi + 4\phi$, and $4\phi + 5\phi$, and Inserting 1 to 3 Recovery Cycles and Accessing External Area

Table 5.61 Memory Expansion Mode and Microprocessor Mode (in Wait State Setting $2\phi + 3\phi$, $2\phi + 4\phi$, $3\phi + 4\phi$, and $4\phi + 5\phi$, and Inserting 1 to 3 Recovery Cycles and Accessing External Area)

Symbol	Parameter	Measuring Condition	Standard		Unit
			Min.	Max.	
$t_{d(BCLK-AD)}$	Address output delay time	See Figure 5.30		30	ns
$t_{h(BCLK-AD)}$	Address output hold time (in relation to BCLK)		0		ns
$t_{h(RD-AD)}$	Address output hold time (in relation to RD)		(Note 4)		ns
$t_{h(WR-AD)}$	Address output hold time (in relation to WR)		(Note 2)		ns
$t_{d(BCLK-CS)}$	Chip select output delay time			30	ns
$t_{h(BCLK-CS)}$	Chip select output hold time (in relation to BCLK)		0		ns
$t_{d(BCLK-ALE)}$	ALE signal output delay time			25	ns
$t_{h(BCLK-ALE)}$	ALE signal output hold time		-4		ns
$t_{d(BCLK-RD)}$	RD signal output delay time			30	ns
$t_{h(BCLK-RD)}$	RD signal output hold time		0		ns
$t_{d(BCLK-WR)}$	WR signal output delay time			30	ns
$t_{h(BCLK-WR)}$	WR signal output hold time		0		ns
$t_{d(BCLK-DB)}$	Data output delay time (in relation to BCLK)			40	ns
$t_{h(BCLK-DB)}$	Data output hold time (in relation to BCLK) ⁽³⁾		0		ns
$t_{d(DB-WR)}$	Data output delay time (in relation to WR)		(Note 1)		ns
$t_{h(WR-DB)}$	Data output hold time (in relation to WR) ⁽³⁾		(Note 2)		ns

Notes:

1. Calculated according to the BCLK frequency as follows:

$$\frac{n \times 10^9}{f_{(BCLK)}} - 40 [ns] \quad n \text{ is 3 for } 2\phi + 3\phi, 4 \text{ for } 2\phi + 4\phi, 4 \text{ for } 3\phi + 4\phi, \text{ and 5 for } 4\phi + 5\phi.$$

2. Calculated according to the BCLK frequency as follows:

$$\frac{m \times 10^9}{f_{(BCLK)}} - 10 [ns] \quad m \text{ is 1 when 1 recovery cycle is inserted, 2 when 2 recovery cycles are inserted, and 3 when 3 recovery cycles are inserted.}$$

3. This standard value shows the timing when the output is off, and does not show hold time of data bus.

Hold time of data bus varies with capacitor volume and pull-up (pull-down) resistance value.

Hold time of data bus is expressed in
 $t = -CR \times \ln(1 - V_{OL}/V_{CC2})$

by a circuit of the right figure.

For example, when $V_{OL} = 0.2V_{CC2}$, $C = 30 \text{ pF}$, $R = 1 \text{ k}\Omega$, hold time of output low level is

$$t = -30 \text{ pF} \times 1 \text{ k}\Omega \times \ln(1 - 0.2V_{CC2}/V_{CC2}) = 6.7 \text{ ns.}$$

4. Calculated according to the BCLK frequency as follows:

$$\frac{m \times 10^9}{f_{(BCLK)}} + 0 [ns] \quad m \text{ is 1 when 1 recovery cycle is inserted, 2 when 2 recovery cycles are inserted, and 3 when 3 recovery cycles are inserted.}$$

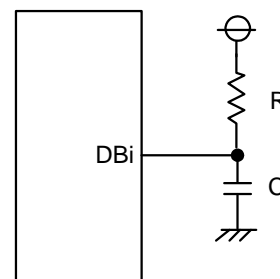

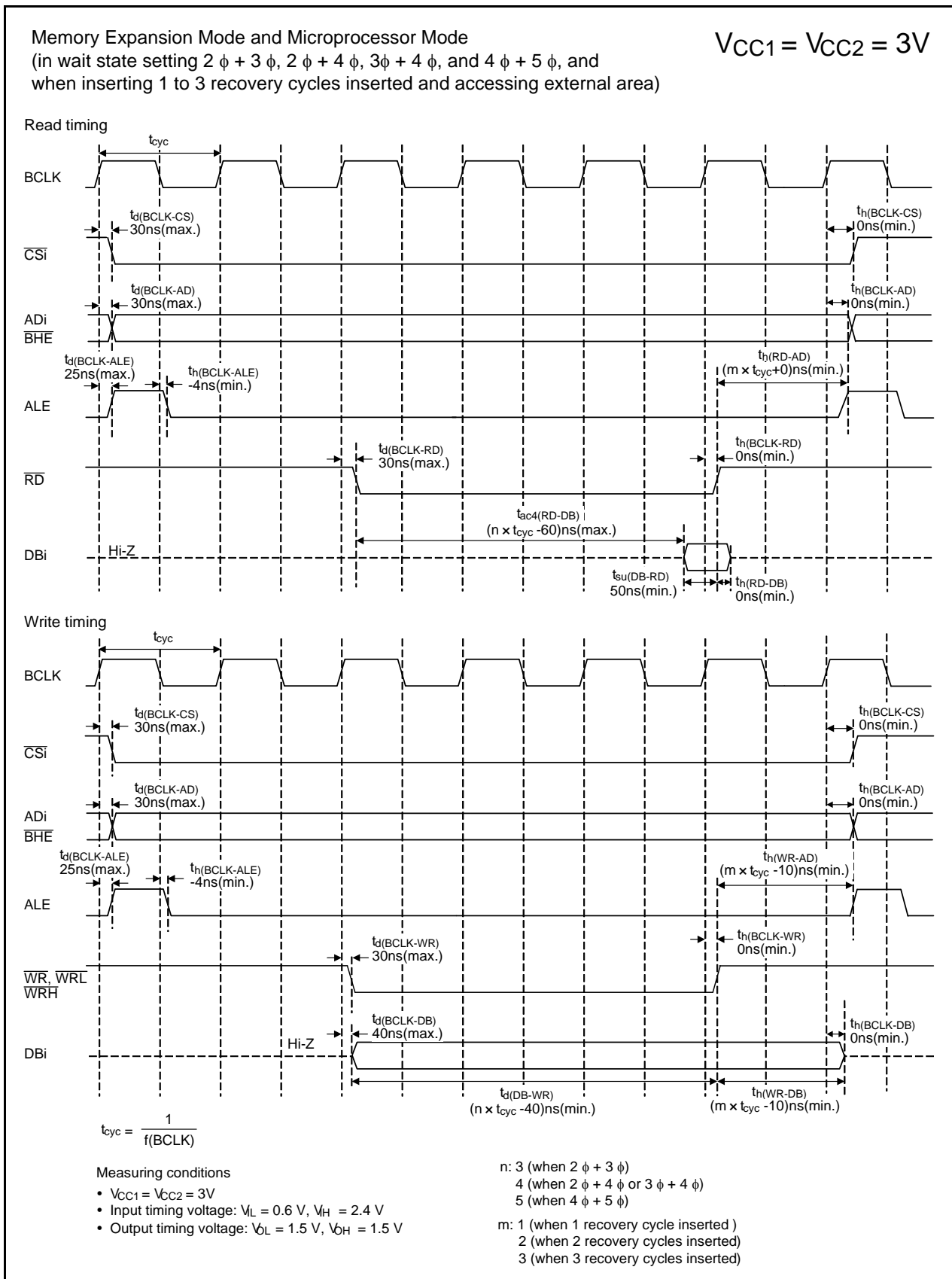

Figure 5.35 Timing Diagram

5.4 Electrical Characteristics ($V_{CC1} = V_{CC2} = 1.8\text{ V}$)

5.4.1 Electrical Characteristics

$$V_{CC1} = V_{CC2} = 1.8\text{ V}$$

Table 5.62 Electrical Characteristics (1) (1)

$1.8\text{ V} \leq V_{CC1} = V_{CC2} < 2.7\text{ V}$, $V_{SS} = 0\text{ V}$ at $T_{opr} = -20^\circ\text{C}$ to $85^\circ\text{C}/-40^\circ\text{C}$ to 85°C , $f_{(BCLK)} = 5\text{ MHz}$ unless otherwise specified.

Symbol	Parameter		Measuring Condition	Standard			Unit
				Min.	Typ.	Max.	
V_{OH}	High output voltage	P6_0 to P6_7, P7_2 to P7_7, P8_0 to P8_4, P8_6, P8_7, P9_0 to P9_7, P10_0 to P10_7	$I_{OH} = -1\text{ mA}$	$V_{CC1} - 0.5$		V_{CC1}	V
		P0_0 to P0_7, P1_0 to P1_7, P2_0 to P2_7, P3_0 to P3_7, P4_0 to P4_7, P5_0 to P5_7	$I_{OH} = -1\text{ mA}$	$V_{CC2} - 0.5$		V_{CC2}	
V_{OH}	High output voltage	XOUT	HIGHPOWER	$I_{OH} = -0.1\text{ mA}$	$V_{CC1} - 0.5$	V_{CC1}	V
			LOWPOWER	$I_{OH} = -50\text{ }\mu\text{A}$	$V_{CC1} - 0.5$	V_{CC1}	
	High output voltage	XCOUT	With no load applied		1.5		V
V_{OL}	Low output voltage	P6_0 to P6_7, P7_0 to P7_7, P8_0 to P8_7, P9_0 to P9_7, P10_0 to P10_7	$I_{OL} = 1\text{ mA}$			0.5	V
		P0_0 to P0_7, P1_0 to P1_7, P2_0 to P2_7, P3_0 to P3_7, P4_0 to P4_7, P5_0 to P5_7	$I_{OL} = 1\text{ mA}$			0.5	
V_{OL}	Low output voltage	XOUT	HIGHPOWER	$I_{OL} = 0.1\text{ mA}$		0.5	V
			LOWPOWER	$I_{OL} = 50\text{ }\mu\text{A}$		0.5	
	Low output voltage	XCOUT	With no load applied		0		V
$V_{T+}-V_{T-}$	Hysteresis	HOLD, RDY, TA0IN to TA4IN, TB0IN to TB5IN, INT0 to INT7, NMI, ADTRG, CTS0 to CTS2, CTS5 to CTS7, SCL0 to SCL2, SCL5 to SCL7, SDA0 to SDA2, SDA5 to SDA7, CLK0 to CLK7, TA0OUT to TA4OUT, KI0 to KI7, RXD0 to RXD2, RXD5 to RXD7, SIN3, SIN4, SD, PMC0, PMC1, SCLMM, SDAMM, CEC	$V_{CC1} = V_{CC2} = 1.8\text{ V}$	0.02		0.1	V
$V_{T+}-V_{T-}$	Hysteresis	RESET	$V_{CC1} = V_{CC2} = 1.8\text{ V}$	0.05		0.15	V
I_{IH}	High input current	P0_0 to P0_7, P1_0 to P1_7, P2_0 to P2_7, P3_0 to P3_7, P4_0 to P4_7, P5_0 to P5_7, P6_0 to P6_7, P7_0 to P7_7, P8_0 to P8_7, P9_0 to P9_7, P10_0 to P10_7 XIN, RESET, CNVSS, BYTE	$V_I = 1.8\text{ V}$			2.0	μA

Note:

1. When $V_{CC1} \neq V_{CC2}$, refer to 5 V, 3 V, or 1.8 V standard depending on the voltage.

$$V_{CC1} = V_{CC2} = 1.8 \text{ V}$$

Table 5.63 Electrical Characteristics (2) (1)

$1.8 \text{ V} \leq V_{CC1} = V_{CC2} < 2.7 \text{ V}$, $V_{SS} = 0 \text{ V}$ at $T_{opr} = -20 \text{ to } 85^\circ\text{C}/-40 \text{ to } 85^\circ\text{C}$, $f_{(BCLK)} = 5 \text{ MHz}$ unless otherwise specified.

Symbol	Parameter		Measuring Condition	Standard			Unit
				Min.	Typ.	Max.	
I_{IL}	Low input current	P0_0 to P0_7, P1_0 to P1_7, P2_0 to P2_7, P3_0 to P3_7, P4_0 to P4_7, P5_0 to P5_7, P6_0 to P6_7, P7_0 to P7_7, P8_0 to P8_7, P9_0 to P9_7, P10_0 to P10_7 XIN, $\overline{\text{RESET}}$, CNVSS, BYTE	$V_I = 0 \text{ V}$			-2.0	μA
R_{PULLUP}	Pull-up resistance	P0_0 to P0_7, P1_0 to P1_7, P2_0 to P2_7, P3_0 to P3_7, P4_0 to P4_7, P5_0 to P5_7, P6_0 to P6_7, P7_2 to P7_7, P8_0 to P8_4, P8_6, P8_7, P9_0 to P9_7, P10_0 to P10_7	$V_I = 0 \text{ V}$	70	140	700	$\text{k}\Omega$
R_{fXIN}	Feedback resistance	XIN			0.8		$\text{M}\Omega$
R_{fXCIN}	Feedback resistance	XCIN			8		$\text{M}\Omega$
V_{RAM}	RAM retention voltage			1.8			V

Note:

1. When $V_{CC1} \neq V_{CC2}$, refer to 5 V, 3 V, or 1.8 V standard depending on the voltage.

$$V_{CC1} = V_{CC2} = 1.8 \text{ V}$$

Table 5.64 Electrical Characteristics (3)

$1.8 \text{ V} \leq V_{CC1} = V_{CC2} < 2.7 \text{ V}$, $V_{SS} = 0 \text{ V}$ at $T_{opr} = -20^\circ\text{C}$ to $85^\circ\text{C}/-40^\circ\text{C}$ to 85°C , $f_{(BCLK)} = 5 \text{ MHz}$ unless otherwise specified.

Symbol	Parameter	Measuring Condition	Standard			Unit
			Min.	Typ.	Max.	
I_{CC}	Power supply current In single-chip mode, the output pin are open and other pins are V_{SS}	High-speed mode	$f_{(BCLK)} = 5 \text{ MHz}$ (no division) XIN = 5 MHz (square wave), 125 kHz on-chip oscillator stop CM15 = 1 (drive capacity High) A/D converter stop		2.6	mA
			$f_{(BCLK)} = 5 \text{ MHz}$ (no division), XIN = 5 MHz (square wave) 125 kHz on-chip oscillator stop CM15 = 1 (drive capacity High) A/D converter operating (2)		3.3	mA
			$f_{(BCLK)} = 5 \text{ MHz}$ XIN = 5 MHz (square wave) 125 kHz on-chip oscillator stop CM15 = 0 (drive capacity Low) A/D converter stop		2.6	mA
			$f_{(BCLK)} = 5 \text{ MHz}$ (no division) XIN = 5 MHz (square wave) 125 kHz on-chip oscillator stop CM15 = 1 (drive capacity High) PCLKSTP1 = FF (peripheral clock stop)		2.2	mA
			$f_{(BCLK)} = 5 \text{ MHz}$ (no division) XIN = 5 MHz (square wave) 125 kHz on-chip oscillator stop CM15 = 0 (drive capacity Low) PCLKSTP1 = FF (peripheral clock stop)		2.2	mA
		40 MHz on-chip oscillator mode	Main clock stop 40 MHz on-chip oscillator on, divide-by-8 ($f_{(BCLK)} = 5 \text{ MHz}$) 125 kHz on-chip oscillator stop		2.8	mA
		125 kHz on-chip oscillator mode	Main clock stop 40 MHz on-chip oscillator stop 125 kHz on-chip oscillator on, no division FMR22 = 1 (slow read mode)		450.0	μA
		Low-power mode	$f_{(BCLK)} = 32 \text{ MHz}$ FMR 22 = FMR23 = 1 (in low-current consumption read mode) on flash memory (1)		80.0	μA
		Wait mode	$f_{(BCLK)} = 32 \text{ kHz}$ Main clock stop 40 MHz on-chip oscillator stop 125 kHz on-chip oscillator on PM25 = 1 (peripheral function clock fC operating) $T_{opr} = 25^\circ\text{C}$ Real-time clock operating		5.3	μA
			$f_{(BCLK)} = 32 \text{ MHz}$ Main clock stop 40 MHz on-chip oscillator stop 125 kHz on-chip oscillator stop PM25 = 0 (peripheral function clock fC stop) $T_{opr} = 25^\circ\text{C}$		5.0	μA
Stop mode	$T_{opr} = 25^\circ\text{C}$		2.2	μA		

Notes:

1. This indicates the memory in which the program to be executed exists
2. A/D conversion is executed in repeat mode.

$$V_{CC1} = V_{CC2} = 1.8 \text{ V}$$

5.4.2 Timing Requirements (Peripheral Functions and Others)

($V_{CC1} = V_{CC2} = 1.8 \text{ V}$, $V_{SS} = 0 \text{ V}$, at $T_{opr} = -20^\circ\text{C}$ to 85°C / -40°C to 85°C unless otherwise specified)

5.4.2.1 Reset Input ($\overline{\text{RESET}}$ Input)

Table 5.65 Reset Input ($\overline{\text{RESET}}$ Input)

Symbol	Parameter	Standard		Unit
		Min.	Max.	
$t_{w(\text{RSTL})}$	$\overline{\text{RESET}}$ input low pulse width	10		μs

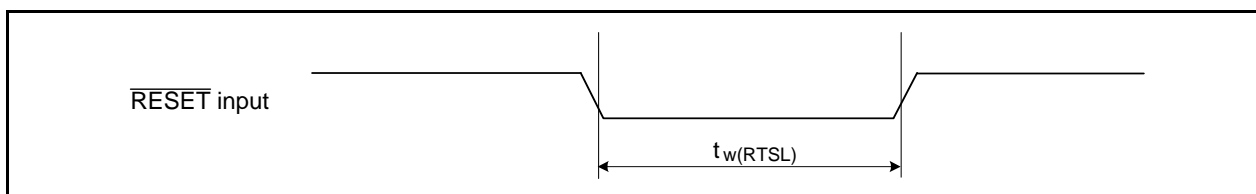

Figure 5.36 Reset Input ($\overline{\text{RESET}}$ Input)

5.4.2.2 External Clock Input

Table 5.66 External Clock Input (XIN Input) (1)

Symbol	Parameter	Standard		Unit
		Min.	Max.	
t_c	External clock input cycle time	100		ns
$t_{w(\text{H})}$	External clock input high pulse width	40		ns
$t_{w(\text{L})}$	External clock input low pulse width	40		ns
t_r	External clock rise time		9	ns
t_f	External clock fall time		9	ns

Note:

- The condition is $1.8 \text{ V} \leq V_{CC1} = V_{CC2} < 2.7 \text{ V}$.

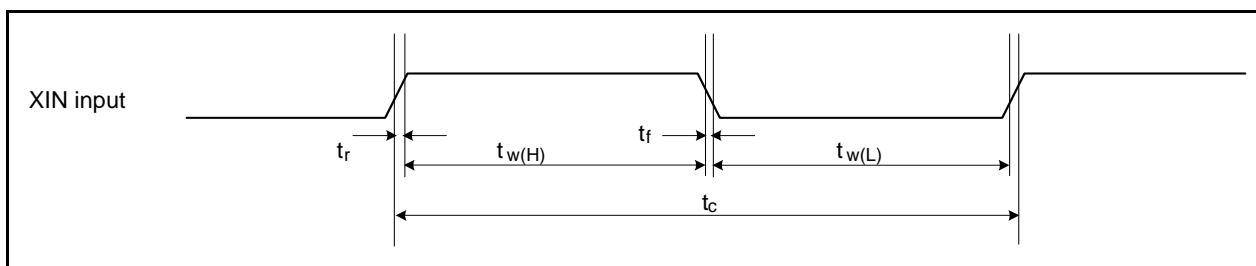

Figure 5.37 External Clock Input (XIN Input)

$$V_{CC1} = V_{CC2} = 1.8 \text{ V}$$

Timing Requirements

($V_{CC1} = V_{CC2} = 1.8 \text{ V}$, $V_{SS} = 0 \text{ V}$, at $T_{opr} = -20^{\circ}\text{C}$ to $85^{\circ}\text{C}/-40^{\circ}\text{C}$ to 85°C unless otherwise specified)

5.4.2.3 Timer A Input

Table 5.67 Timer A Input (Counter Input in Event Counter Mode)

Symbol	Parameter	Standard		Unit
		Min.	Max.	
$t_{c(TA)}$	TAiIN input cycle time	500		ns
$t_{w(TAH)}$	TAiIN input high pulse width	200		ns
$t_{w(TAL)}$	TAiIN input low pulse width	200		ns

Table 5.68 Timer A Input (Gating Input in Timer Mode)

Symbol	Parameter	Standard		Unit
		Min.	Max.	
$t_{c(TA)}$	TAiIN input cycle time	1000		ns
$t_{w(TAH)}$	TAiIN input high pulse width	500		ns
$t_{w(TAL)}$	TAiIN input low pulse width	500		ns

Table 5.69 Timer A Input (External Trigger Input in One-Shot Timer Mode)

Symbol	Parameter	Standard		Unit
		Min.	Max.	
$t_{c(TA)}$	TAiIN input cycle time	800		ns
$t_{w(TAH)}$	TAiIN input high pulse width	400		ns
$t_{w(TAL)}$	TAiIN input low pulse width	400		ns

Table 5.70 Timer A Input (External Trigger Input in Pulse Width Modulation Mode and Programmable Output Mode)

Symbol	Parameter	Standard		Unit
		Min.	Max.	
$t_{w(TAH)}$	TAiIN input high pulse width	400		ns
$t_{w(TAL)}$	TAiIN input low pulse width	400		ns

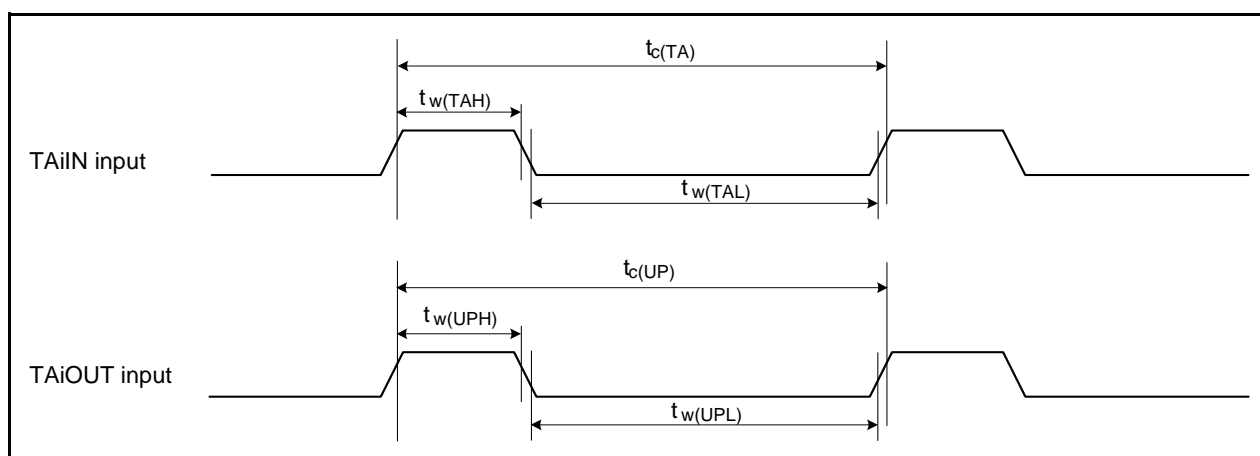

Figure 5.38 Timer A Input

$$V_{CC1} = V_{CC2} = 1.8 \text{ V}$$

Timing Requirements

($V_{CC1} = V_{CC2} = 1.8 \text{ V}$, $V_{SS} = 0 \text{ V}$, at $T_{opr} = -20^\circ\text{C}$ to $85^\circ\text{C}/-40^\circ\text{C}$ to 85°C unless otherwise specified)

Table 5.71 Timer A Input (Two-Phase Pulse Input in Event Counter Mode)

Symbol	Parameter	Standard		Unit
		Min.	Max.	
$t_{c(TA)}$	TAiIN input cycle time	3		μs
$t_{su(TAIN-TAOUT)}$	TAiOUT input setup time	800		ns
$t_{su(TAOUT-TAIN)}$	TAiIN input setup time	800		ns

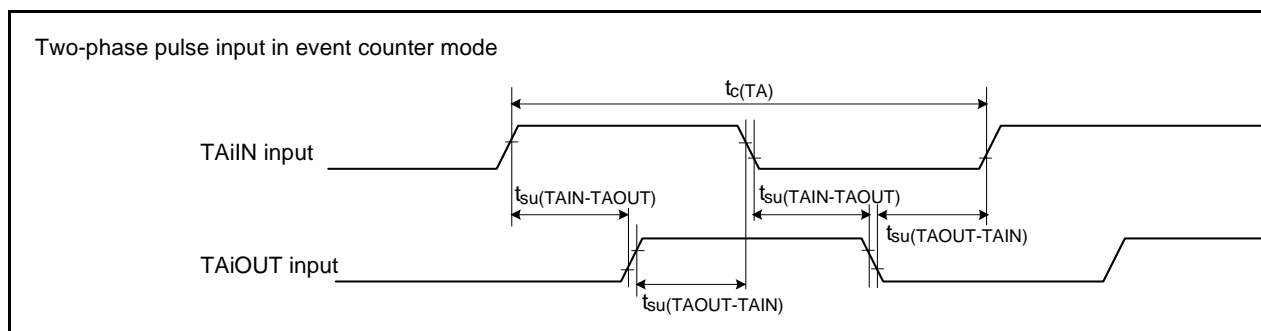
**Figure 5.39 Timer A Input (Two-Phase Pulse Input in Event Counter Mode)**

$$V_{CC1} = V_{CC2} = 1.8 \text{ V}$$

Timing Requirements

($V_{CC1} = V_{CC2} = 1.8 \text{ V}$, $V_{SS} = 0 \text{ V}$, at $T_{opr} = -20^\circ\text{C}$ to $85^\circ\text{C}/-40^\circ\text{C}$ to 85°C unless otherwise specified)

5.4.2.4 Timer B Input

Table 5.72 Timer B Input (Counter Input in Event Counter Mode)

Symbol	Parameter	Standard		Unit
		Min.	Max.	
$t_{c(TB)}$	TBiIN input cycle time (counted on one edge)	300		ns
$t_{w(TBH)}$	TBiIN input high pulse width (counted on one edge)	120		ns
$t_{w(TBL)}$	TBiIN input low pulse width (counted on one edge)	120		ns
$t_{c(TB)}$	TBiIN input cycle time (counted on both edges)	600		ns
$t_{w(TBH)}$	TBiIN input high pulse width (counted on both edges)	240		ns
$t_{w(TBL)}$	TBiIN input low pulse width (counted on both edges)	240		ns

Table 5.73 Timer B Input (Pulse Period Measurement Mode)

Symbol	Parameter	Standard		Unit
		Min.	Max.	
$t_{c(TB)}$	TBiIN input cycle time	1000		ns
$t_{w(TBH)}$	TBiIN input high pulse width	500		ns
$t_{w(TBL)}$	TBiIN input low pulse width	500		ns

Table 5.74 Timer B Input (Pulse Width Measurement Mode)

Symbol	Parameter	Standard		Unit
		Min.	Max.	
$t_{c(TB)}$	TBiIN input cycle time	1000		ns
$t_{w(TBH)}$	TBiIN input high pulse width	500		ns
$t_{w(TBL)}$	TBiIN input low pulse width	500		ns

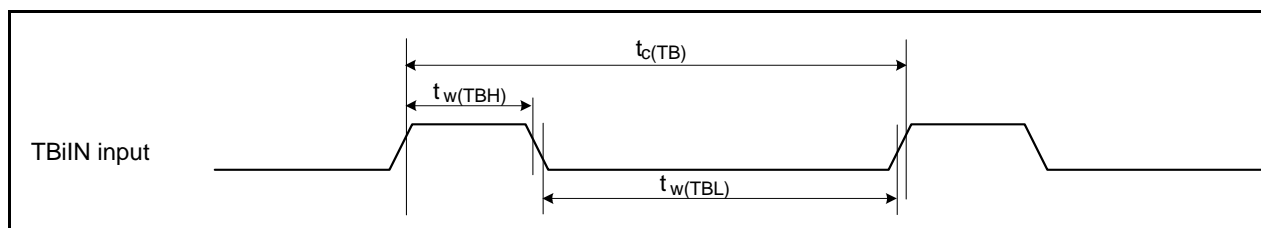

Figure 5.40 Timer B Input

$$V_{CC1} = V_{CC2} = 1.8 \text{ V}$$

Timing Requirements

($V_{CC1} = V_{CC2} = 1.8 \text{ V}$, $V_{SS} = 0 \text{ V}$, at $T_{opr} = -20^\circ\text{C}$ to $85^\circ\text{C}/-40^\circ\text{C}$ to 85°C unless otherwise specified)

5.4.2.5 Serial Interface

Table 5.75 Serial Interface

Symbol	Parameter	Standard		Unit
		Min.	Max.	
$t_{c(CK)}$	CLKi input cycle time	800		ns
$t_{w(CKH)}$	CLKi input high pulse width	400		ns
$t_{w(CKL)}$	CLKi input low pulse width	400		ns
$t_{d(C-Q)}$	TXDi output delay time		240	ns
$t_{h(C-Q)}$	TXDi hold time	0		ns
$t_{su(D-C)}$	RXDi input setup time	200		ns
$t_{h(C-D)}$	RXDi input hold time	90		ns

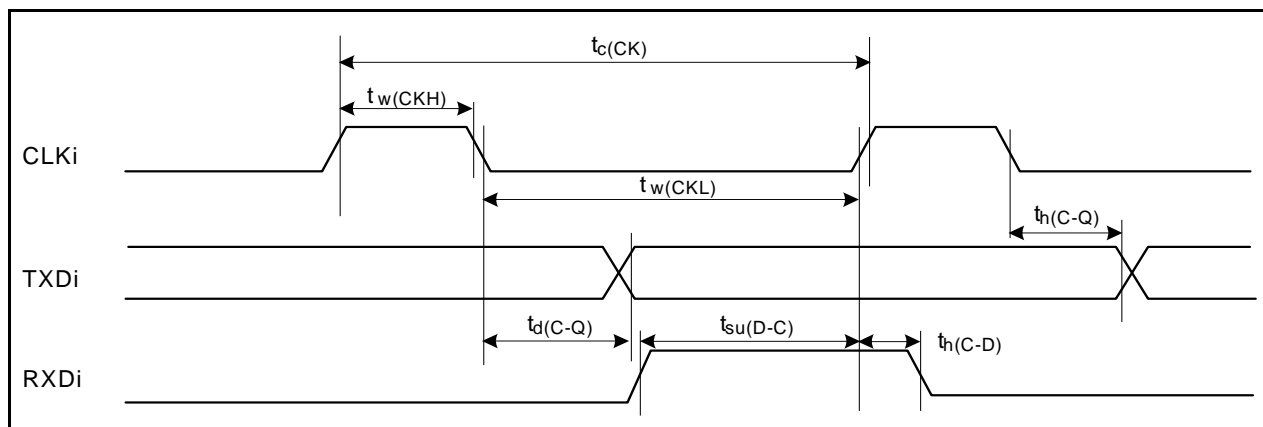

Figure 5.41 Serial Interface

5.4.2.6 External Interrupt \overline{INTi} Input

Table 5.76 External Interrupt \overline{INTi} Input

Symbol	Parameter	Standard		Unit
		Min.	Max.	
$t_{w(INH)}$	\overline{INTi} input high pulse width	1000		ns
$t_{w(INL)}$	\overline{INTi} input low pulse width	1000		ns
$t_r(INT)$	\overline{INTi} input rising time		100	μs
$t_f(INT)$	\overline{INTi} input falling time		100	μs

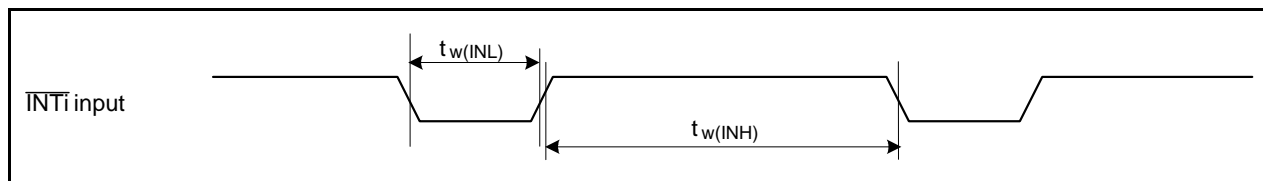

Figure 5.42 External Interrupt \overline{INTi} Input

$$V_{CC1} = V_{CC2} = 1.8 \text{ V}$$

Timing Requirements

($V_{CC1} = V_{CC2} = 1.8 \text{ V}$, $V_{SS} = 0 \text{ V}$, at $T_{opr} = -20^{\circ}\text{C}$ to $85^{\circ}\text{C}/-40^{\circ}\text{C}$ to 85°C unless otherwise specified)

5.4.2.7 Multi-master I²C-bus

Table 5.77 Multi-master I²C-bus

Symbol	Parameter	Standard Clock Mode		Fast-mode		Unit
		Min.	Max.	Min.	Max.	
t_{BUF}	Bus free time	4.7		1.3		μs
$t_{HD;STA}$	Hold time in start condition	4.0		0.6		μs
t_{LOW}	Hold time in SCL clock 0 status	4.7		1.3		μs
t_R	SCL, SDA signals' rising time		1000	$20 + 0.1 C_b$	300	ns
$t_{HD;DAT}$	Data hold time	0		0	0.9	μs
t_{HIGH}	Hold time in SCL clock 1 status	4.0		0.6		μs
t_F	SCL, SDA signals' falling time		300	$20 + 0.1 C_b$	300	ns
$t_{su;DAT}$	Data setup time	250		100		ns
$t_{su;STA}$	Setup time in restart condition	4.7		0.6		μs
$t_{su;STO}$	Stop condition setup time	4.0		0.6		μs

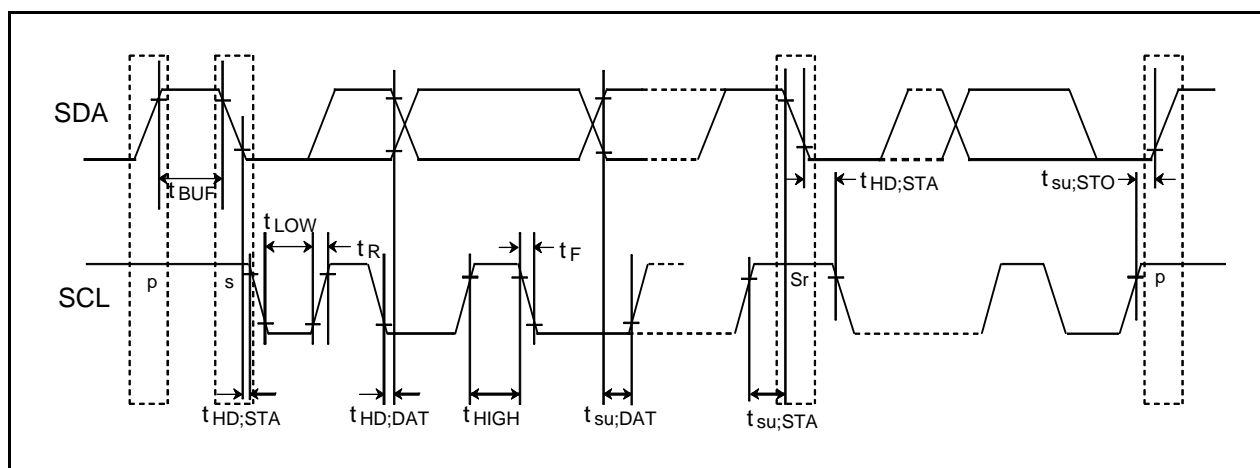
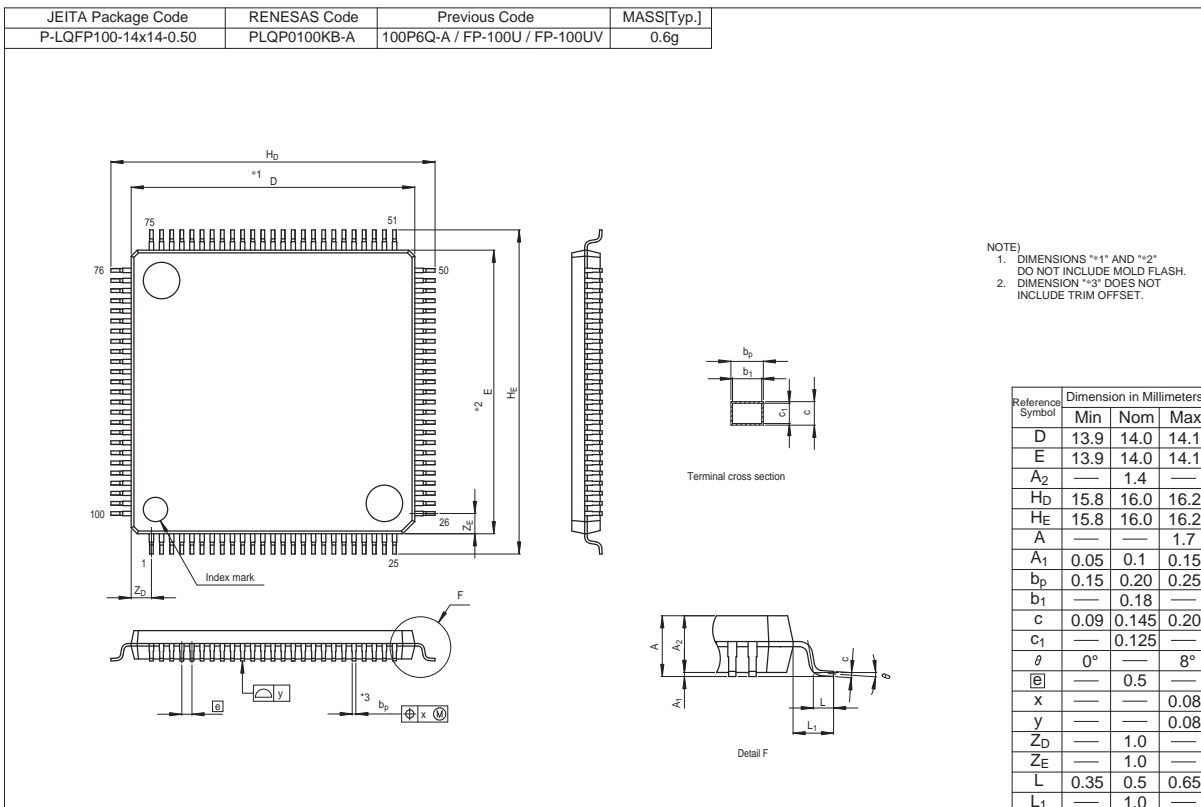
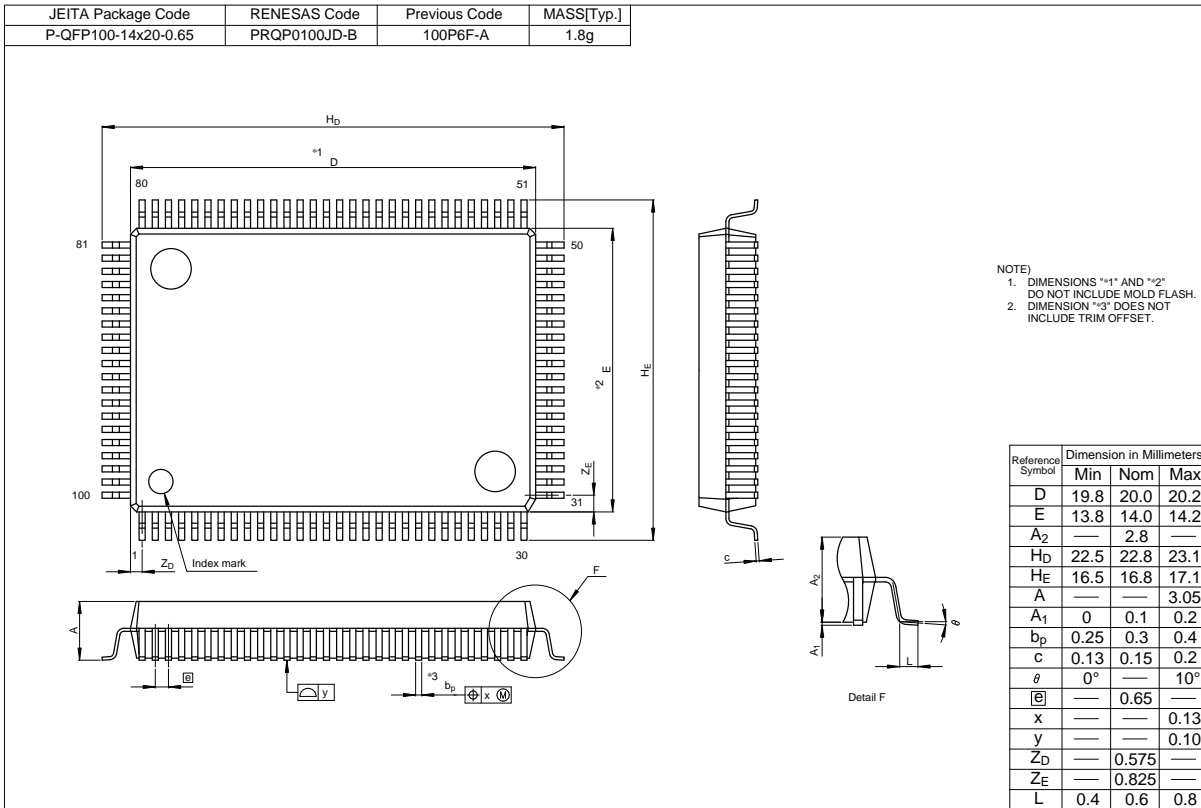
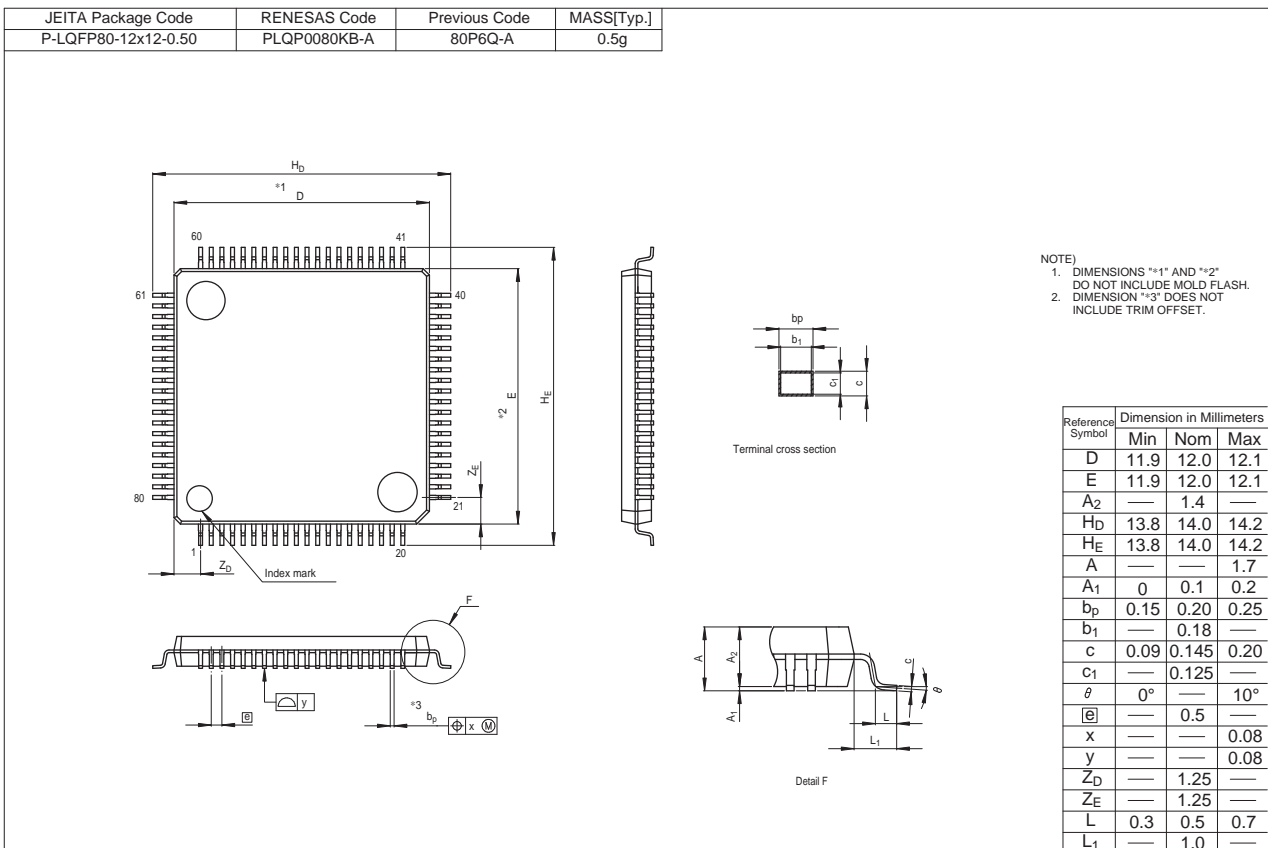
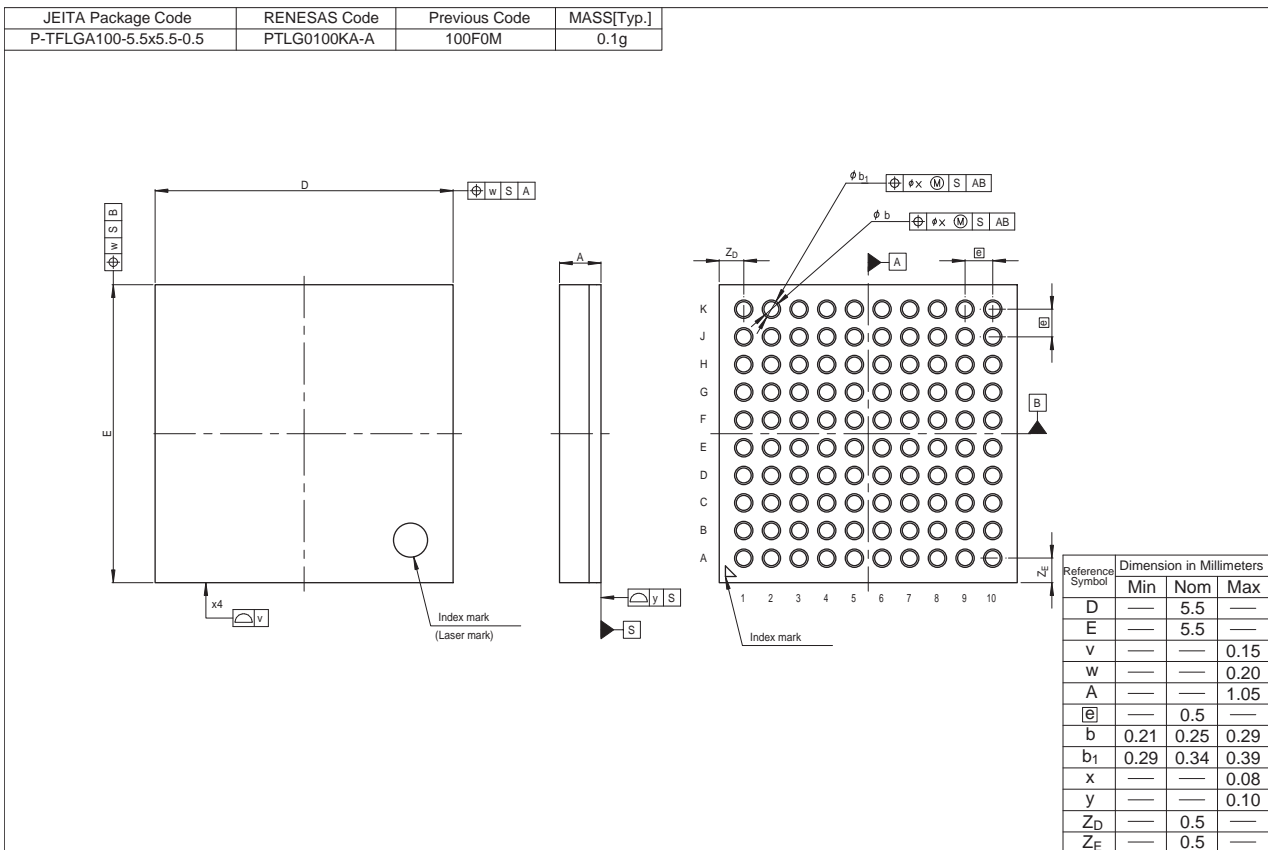

Figure 5.43 Multi-master I²C-bus

Appendix 1. Package Dimensions

The information on the latest package dimensions or packaging may be obtained from "Packages" on the Renesas Electronics website.





REVISION HISTORY	M16C/63 Group Datasheet
------------------	-------------------------

Rev.	Date	Description			
		Page	Summary		
0.30	Jul 15, 2009	-	First Edition issued.		
0.40	Aug 18, 2009	3	Table 1.2 "Specifications for the 100-Pin Package (2/2)" partially modified		
		6	Table 1.5 "Product List" partially modified		
		7	Figure 1.1 "Part No., with Memory Size and Package" partially modified		
		12	Figure 1.7 "Pin Assignment for the 100-Pin Package" added		
		13	Table 1.6 "Pin Names for the 100-Pin Package (1/2)" partially modified		
		14	Table 1.7 "Pin Names for the 100-Pin Package (2/2)" partially modified		
		107	Table 5.65 "External Clock Input (XIN Input)" partially modified		
		112	Appendix 1. "Package Dimensions" PTLG0100KA-A added		
		0.41	Aug 25, 2009	6	Table 1.5 "Product List" Part No. partially modified
7	Figure 1.3 "Marking Diagram (Top View) (2/2)" added				
1.00	Sep 15, 2009	52	Table 5.6 "A/D Conversion Characteristics (1/2)" note 3 added		
2.00	Feb 07, 2011	Overall	001Ah Voltage Detector Operation Enable Register: Changed reset value from "000X 0000b".		
		Overall	002Ah Voltage Monitor 0 Control Register: Changed reset value from "1100 XX10b".		
		Overall	002Bh Voltage Monitor 1 Control Register: Changed reset value from "1000 1X10b".		
		Overall	0324h Increment/Decrement Flag: Changed name from Up/Down Flag.		
		Overall	03DCh D/A Control Register: Changed reset value from "XXXX XX00b".		
		Overall	D08Ah to D08Bh PMCO Counter Value Register: Deleted.		
		Overall	D09Eh to D09Fh PMC1 Counter Value Register: Deleted.		
		Overview			
		3, 5	Table 1.2 and Table 1.4 Specifications for the 100/80-Pin Package: Deleted note 1.		
		6	Table 1.5 Product List: Changed the development status.		
		18	Table 1.10 Pin Functions for the 100-Pin Package (1/3): Changed the descriptions of the HOLD pin.		
		Address Space			
		27	Figure 3.2 Memory Map: Added note 1 and 3 to the reserved areas.		
		Special Function Registers (SFRs)			
		29	Table 4.1 SFR Information (1): <ul style="list-style-type: none"> • Deleted "the VCR1 register, the VCR2 register" from note 2. • Deleted notes 5 to 6 and added note 5. 		
		30	Table 4.2 SFR Information (2): Deleted notes 2 to 7 and added note 2.		
		47	4.2.1 Register Settings: Added the description regarding read-modify-write instructions.		
		48	Table 4.20 Read-Modify-Write Instructions: Added.		
		Electrical Characteristics			
		49	Table 5.1 Absolute Maximum Ratings: Divide a row for T_{opr} (Flash program erase) into Program area and Data area.		
		50	Table 5.2 Recommended Operating Conditions (1/4): Added rows for the CEC value to V_{CC1} , V_{IH} , and V_{IL} .		
		56	Table 5.9 CPU Clock When Operating Flash Memory ($f_{(BCLK)}$): Added note 3.		
		56	Table 5.10 Flash Memory (Program ROM 1, 2) Electrical Characteristics: Added a condition to the Read voltage row.		
59	Table 5.15 Power-On Reset Circuit: <ul style="list-style-type: none"> • Changed the maximum value for V_{por1} from 0.1. • Added the $t_{w(por)}$ row. • Added the last line in note 1. 				
59	Figure 5.4 Power-On Reset Circuit Electrical Characteristics: Deleted note 2.				
61	Table 5.17 40 MHz On-Chip Oscillator Electrical Characteristics: Deleted note 1.				
63	Table 5.20 Electrical Characteristics (2): Added "ZP, IDU, IDV, IDW" to the $V_{T+} - V_T$ row.				
70, 91, 113	5.2.2.7, 5.3.2.7, and 5.4.2.7 Multi-master I ² C-bus: Added.				
71	Table 5.35 Memory Expansion Mode and Microprocessor Mode: Changed RDY input setup time from 30.				

REVISION HISTORY	M16C/63 Group Datasheet
------------------	-------------------------

Rev.	Date	Description	
		Page	Summary
2.00	Feb 07, 2011	71 to 78, 92 to 99	Table 5.35 to Table 5.40 and Table 5.56 to Table 5.61 Memory Expansion Mode and Microprocessor Mode: Deleted the following: <ul style="list-style-type: none"> • $\overline{\text{HOLD}}$ input setup time • $\overline{\text{HOLD}}$ input hold time • HLDA output delay time
		72, 93	Figure 5.14 and Figure 5.29 Timing Diagram: Deleted lower figure (Common to wait state and no wait state settings).
		83, 104	Figure 5.20 and Figure 5.35 Timing Diagram: Changed the width of $t_{\text{h}}(\text{RD-AD})$.
		84	Table 5.41 Electrical Characteristics (1): <ul style="list-style-type: none"> • Added rows for the CEC value to V_{OL}, $V_{\text{T+}}$-$V_{\text{T-}}$, and Leakage current in powered-off state. • Added "ZP, IDU, IDV, IDW" to the $V_{\text{T+}}$ - $V_{\text{T-}}$ row.
		85	Table 5.42 Electrical Characteristics (2): Changed " $V_{\text{CC1}} = 5.0 \text{ V}$ " to " $V_{\text{CC1}} = 3.0 \text{ V}$ " in the During flash memory program and During flash memory erase rows.
		92	Table 5.56 Memory Expansion Mode and Microprocessor Mode: Changed RDY input setup time from 40.
		105	Table 5.62 Electrical Characteristics (1): <ul style="list-style-type: none"> • Changed the Measuring Condition over the table. • Added "ZP, IDU, IDV, IDW" to the Parameter column and the value to the Measuring Condition in the $V_{\text{T+}}$ - $V_{\text{T-}}$ row. • Changed the Measuring Condition in the I_{IH} row.
		106, 107	Table 5.63 Electrical Characteristics (2) and Table 5.64 Electrical Characteristics (3): Changed the Measuring Condition over the table.
		108	Table 5.66 External Clock Input (XIN Input): Changed the condition in note 1.
2.20	Nov 01, 2012	Overview	
		2	Table 1.1 Specifications for the 100-Pin Package (1/2): Added the condition for 100.0 ns and changed the condition for 200 ns in the Minimum instruction execution time in the Description column of the CPU.
		3	Table 1.2 Specifications for the 100-Pin Package (2/2): Added "10 MHz/ $V_{\text{CC1}} = 2.1$ to 5.5 V, $V_{\text{CC2}} = 2.1 \text{ V}$ to V_{CC1} " to the Description column of the Operation Frequency/Supply Voltage.
		4	Table 1.3 Specifications for the 80-Pin Package (1/2): Added the condition for 100.0 ns and changed the condition for 200 ns in the Minimum instruction execution time in the Description column of the CPU.
		5	Table 1.4 Specifications for the 80-Pin Package (2/2): Added "10 MHz/ $V_{\text{CC1}} = 2.1$ to 5.5 V" to the Description column of the Operation Frequency/Supply Voltage.
		Electrical Characteristics	
		52	Table 5.4 Recommended Operating Conditions (3/4) <ul style="list-style-type: none"> • Changed the Parameter "$2.7 \text{ V} \leq V_{\text{CC1}} < 5.5 \text{ V}$" to "$2.7 \text{ V} \leq V_{\text{CC1}} < 5.5 \text{ V}$, $1 \text{ MHz} \leq f_{(\text{XIN})} \leq 20 \text{ MHz}$" in $f_{(\text{BCLK})}$. • Added the line for "$2.1 \text{ V} \leq V_{\text{CC1}} < 2.7 \text{ V}$, $1 \text{ MHz} \leq f_{(\text{XIN})} \leq 10 \text{ MHz}$" in $f_{(\text{BCLK})}$. • Changed the Parameter "$1.8 \text{ V} \leq V_{\text{CC1}} < 2.7 \text{ V}$" to "$1.8 \text{ V} \leq V_{\text{CC1}} < 2.1 \text{ V}$, $1 \text{ MHz} \leq f_{(\text{XIN})} \leq 10 \text{ MHz}$" in $f_{(\text{BCLK})}$.
		53	Figure 5.1 Relation between $f_{(\text{BCLK})}$ and V_{CC1} : Modified the range of $2.1 \text{ V} \leq V_{\text{CC1}} < 2.7 \text{ V}$.

All trademarks and registered trademarks are the property of their respective owners.

HDMI and High-Definition Multimedia Interface are registered trademarks of HDMI Licensing, LLC.

General Precautions in the Handling of MPU/MCU Products

The following usage notes are applicable to all MPU/MCU products from Renesas. For detailed usage notes on the products covered by this manual, refer to the relevant sections of the manual. If the descriptions under General Precautions in the Handling of MPU/MCU Products and in the body of the manual differ from each other, the description in the body of the manual takes precedence.

1. Handling of Unused Pins

Handle unused pins in accord with the directions given under Handling of Unused Pins in the manual.

- The input pins of CMOS products are generally in the high-impedance state. In operation with an unused pin in the open-circuit state, extra electromagnetic noise is induced in the vicinity of LSI, an associated shoot-through current flows internally, and malfunctions occur due to the false recognition of the pin state as an input signal become possible. Unused pins should be handled as described under Handling of Unused Pins in the manual.

2. Processing at Power-on

The state of the product is undefined at the moment when power is supplied.

- The states of internal circuits in the LSI are indeterminate and the states of register settings and pins are undefined at the moment when power is supplied.

In a finished product where the reset signal is applied to the external reset pin, the states of pins are not guaranteed from the moment when power is supplied until the reset process is completed.

In a similar way, the states of pins in a product that is reset by an on-chip power-on reset function are not guaranteed from the moment when power is supplied until the power reaches the level at which resetting has been specified.

3. Prohibition of Access to Reserved Addresses

Access to reserved addresses is prohibited.

- The reserved addresses are provided for the possible future expansion of functions. Do not access these addresses; the correct operation of LSI is not guaranteed if they are accessed.

4. Clock Signals

After applying a reset, only release the reset line after the operating clock signal has become stable. When switching the clock signal during program execution, wait until the target clock signal has stabilized.

- When the clock signal is generated with an external resonator (or from an external oscillator) during a reset, ensure that the reset line is only released after full stabilization of the clock signal. Moreover, when switching to a clock signal produced with an external resonator (or by an external oscillator) while program execution is in progress, wait until the target clock signal is stable.

5. Differences between Products

Before changing from one product to another, i.e. to one with a different part number, confirm that the change will not lead to problems.

- The characteristics of MPU/MCU in the same group but having different part numbers may differ because of the differences in internal memory capacity and layout pattern. When changing to products of different part numbers, implement a system-evaluation test for each of the products.

Notice

1. Descriptions of circuits, software and other related information in this document are provided only to illustrate the operation of semiconductor products and application examples. You are fully responsible for the incorporation of these circuits, software, and information in the design of your equipment. Renesas Electronics assumes no responsibility for any losses incurred by you or third parties arising from the use of these circuits, software, or information.
 2. Renesas Electronics has used reasonable care in preparing the information included in this document, but Renesas Electronics does not warrant that such information is error free. Renesas Electronics assumes no liability whatsoever for any damages incurred by you resulting from errors in or omissions from the information included herein.
 3. Renesas Electronics does not assume any liability for infringement of patents, copyrights, or other intellectual property rights of third parties by or arising from the use of Renesas Electronics products or technical information described in this document. No license, express, implied or otherwise, is granted hereby under any patents, copyrights or other intellectual property rights of Renesas Electronics or others.
 4. You should not alter, modify, copy, or otherwise misappropriate any Renesas Electronics product, whether in whole or in part. Renesas Electronics assumes no responsibility for any losses incurred by you or third parties arising from such alteration, modification, copy or otherwise misappropriation of Renesas Electronics product.
 5. Renesas Electronics products are classified according to the following two quality grades: "Standard" and "High Quality". The recommended applications for each Renesas Electronics product depends on the product's quality grade, as indicated below.
"Standard": Computers; office equipment; communications equipment; test and measurement equipment; audio and visual equipment; home electronic appliances; machine tools; personal electronic equipment; and industrial robots etc.
"High Quality": Transportation equipment (automobiles, trains, ships, etc.); traffic control systems; anti-disaster systems; anti-crime systems; and safety equipment etc.
Renesas Electronics products are neither intended nor authorized for use in products or systems that may pose a direct threat to human life or bodily injury (artificial life support devices or systems, surgical implantations etc.), or may cause serious property damages (nuclear reactor control systems, military equipment etc.). You must check the quality grade of each Renesas Electronics product before using it in a particular application. You may not use any Renesas Electronics product for any application for which it is not intended. Renesas Electronics shall not be in any way liable for any damages or losses incurred by you or third parties arising from the use of any Renesas Electronics product for which the product is not intended by Renesas Electronics.
 6. You should use the Renesas Electronics products described in this document within the range specified by Renesas Electronics, especially with respect to the maximum rating, operating supply voltage range, movement power voltage range, heat radiation characteristics, installation and other product characteristics. Renesas Electronics shall have no liability for malfunctions or damages arising out of the use of Renesas Electronics products beyond such specified ranges.
 7. Although Renesas Electronics endeavors to improve the quality and reliability of its products, semiconductor products have specific characteristics such as the occurrence of failure at a certain rate and malfunctions under certain use conditions. Further, Renesas Electronics products are not subject to radiation resistance design. Please be sure to implement safety measures to guard them against the possibility of physical injury, and injury or damage caused by fire in the event of the failure of a Renesas Electronics product, such as safety design for hardware and software including but not limited to redundancy, fire control and malfunction prevention, appropriate treatment for aging degradation or any other appropriate measures. Because the evaluation of microcomputer software alone is very difficult, please evaluate the safety of the final products or systems manufactured by you.
 8. Please contact a Renesas Electronics sales office for details as to environmental matters such as the environmental compatibility of each Renesas Electronics product. Please use Renesas Electronics products in compliance with all applicable laws and regulations that regulate the inclusion or use of controlled substances, including without limitation, the EU RoHS Directive. Renesas Electronics assumes no liability for damages or losses occurring as a result of your noncompliance with applicable laws and regulations.
 9. Renesas Electronics products and technology may not be used for or incorporated into any products or systems whose manufacture, use, or sale is prohibited under any applicable domestic or foreign laws or regulations. You should not use Renesas Electronics products or technology described in this document for any purpose relating to military applications or use by the military, including but not limited to the development of weapons of mass destruction. When exporting the Renesas Electronics products or technology described in this document, you should comply with the applicable export control laws and regulations and follow the procedures required by such laws and regulations.
 10. It is the responsibility of the buyer or distributor of Renesas Electronics products, who distributes, disposes of, or otherwise places the product with a third party, to notify such third party in advance of the contents and conditions set forth in this document, Renesas Electronics assumes no responsibility for any losses incurred by you or third parties as a result of unauthorized use of Renesas Electronics products.
 11. This document may not be reproduced or duplicated in any form, in whole or in part, without prior written consent of Renesas Electronics.
 12. Please contact a Renesas Electronics sales office if you have any questions regarding the information contained in this document or Renesas Electronics products, or if you have any other inquiries.
- (Note 1) "Renesas Electronics" as used in this document means Renesas Electronics Corporation and also includes its majority-owned subsidiaries.
(Note 2) "Renesas Electronics product(s)" means any product developed or manufactured by or for Renesas Electronics.



SALES OFFICES

Renesas Electronics Corporation

<http://www.renesas.com>

Refer to "<http://www.renesas.com/>" for the latest and detailed information.

Renesas Electronics America Inc.
2880 Scott Boulevard Santa Clara, CA 95050-2554, U.S.A.
Tel: +1-408-588-6000, Fax: +1-408-588-6130

Renesas Electronics Canada Limited
1101 Nicholson Road, Newmarket, Ontario L3Y 9C3, Canada
Tel: +1-905-898-5441, Fax: +1-905-898-3220

Renesas Electronics Europe Limited
Dukes Meadow, Millboard Road, Bourne End, Buckinghamshire, SL8 5FH, U.K.
Tel: +44-1628-651-700, Fax: +44-1628-651-804

Renesas Electronics Europe GmbH
Arcadiastrasse 10, 40472 Düsseldorf, Germany
Tel: +49-211-65030, Fax: +49-211-6503-1327

Renesas Electronics (China) Co., Ltd.
7th Floor, Quantum Plaza, No.27 ZhiChunLu Haidian District, Beijing 100083, P.R.China
Tel: +86-10-8235-1155, Fax: +86-10-8235-7679

Renesas Electronics (Shanghai) Co., Ltd.
Unit 204, 205, AZIA Center, No.1233 Lujiazui Ring Rd., Pudong District, Shanghai 200120, China
Tel: +86-21-5877-1818, Fax: +86-21-6887-7858 / -7898

Renesas Electronics Hong Kong Limited
Unit 1601-1613, 16/F., Tower 2, Grand Century Place, 193 Prince Edward Road West, Mongkok, Kowloon, Hong Kong
Tel: +852-2886-9318, Fax: +852 2886-9022/9044

Renesas Electronics Taiwan Co., Ltd.
13F, No. 363, Fu Shing North Road, Taipei, Taiwan
Tel: +886-2-8175-9600, Fax: +886 2-8175-9670

Renesas Electronics Singapore Pte. Ltd.
80 Bendemeer Road, Unit #06-02 Hyflux Innovation Centre Singapore 339949
Tel: +65-6213-0200, Fax: +65-6213-0300

Renesas Electronics Malaysia Sdn.Bhd.
Unit 906, Block B, Menara Amcorp, Amcorp Trade Centre, No. 18, Jln Persiaran Barat, 46050 Petaling Jaya, Selangor Darul Ehsan, Malaysia
Tel: +60-3-7955-3390, Fax: +60-3-7955-9510

Renesas Electronics Korea Co., Ltd.
11F., Samik Laved. or Bldg., 720-2 Yeoksam-Dong, Kangnam-Ku, Seoul 135-080, Korea
Tel: +82-2-558-3737, Fax: +82-2-558-5141