



ON Semiconductor®

<http://onsemi.com>

LB11920

Monolithic Digital IC For OA Products Three-Phase Brushless Motor Driver

Overview

The LB11920 is a direct PWM drive motor driver IC for 3-phase power brushless motors. The PWM duty can be controlled by IC inputs, and it can be used over the wide supply voltage range of 9.5 to 30V.

Features

- Three-phase bipolar drive (35V, 3.5V)
- Direct PWM drive
- Built-in high and low side kickback absorbing diodes
- Braking function (short-circuit braking)
- Built-in forward/reverse direction switching circuit
- Full complement of built-in protection circuits, including current limiter, low-voltage protection, motor lock (physical constraint) protection, and thermal protection circuits
- The PWM duty can be controlled by IC inputs

Specifications

Absolute Maximum Ratings at $T_a = 25^\circ\text{C}$

Parameter	Symbol	Conditions	Ratings	Unit
Supply voltage 1	V_M max		35	V
Supply voltage 2	V_{CC} max		7	V
Output voltage	V_{OUT} max	OUT1 to OUT3	35	V
Output current	I_O max	$T \leq 500\text{ms}$	3.5	A
Allowable power dissipation	P_d max1	Independent IC	3	W
	P_d max2	With an infinitely large heat sink.	20	W
Operating temperature	T_{opr}		-20 to +80	$^\circ\text{C}$
Storage temperature	T_{stg}		-55 to +150	$^\circ\text{C}$

Stresses exceeding Maximum Ratings may damage the device. Maximum Ratings are stress ratings only. Functional operation above the Recommended Operating Conditions is not implied. Extended exposure to stresses above the Recommended Operating Conditions may affect device reliability.

LB11920

Allowable Operating Conditions at $T_a = 25^\circ\text{C}$

Parameter	Symbol	Conditions	Ratings	Unit
Supply voltage range 1	VM		9.5 to 30	V
Supply voltage range 2	V _{CC}		4.5 to 5.5	V
HP pin applied voltage	VHP		0 to 32	V
HP pin output current	IHP		0 to 3	mA

Electrical Characteristics at $T_a = 25^\circ\text{C}$, VM = RF = 27V, V_{CC} = 5V

Parameter	Symbol	Conditions	Ratings			Unit
			min	typ	max	
Supply current 1	I _{VCC-1}	V _{CC} pin		9	13	mA
Supply current 2	I _{VCC-2}	V _{CC} pin at stop mode		2.0	3.0	mA
Output block						
Output saturation voltage 1	V _{O sat1}	I _O = 1.0A, V _O (sink) + V _O (source)		1.7	2.4	V
Output saturation voltage 2	V _{O sat2}	I _O = 2.0A, V _O (sink) + V _O (source)		2.0	2.9	V
Output saturation voltage 3	V _{O sat3}	I _O = 3.0A, V _O (sink) + V _O (source)		2.4	3.5	V
Output leakage current	I _{O leak}				100	μA
Output delay time 1	td1	PWMIN "H" → "L"		1.25	2.5	μs
Output delay time 2	td2	PWMIN "L" → "H"		1.8	3.6	μs
Lower diode forward 1	VD1-1	ID = -1.0A		1.1	1.5	V
Lower diode forward 2	VD1-2	ID = -2.0A		1.3	1.9	V
Lower diode forward 3	VD1-3	ID = -3.0A		1.5	2.3	V
Upper diode forward 1	VD2-1	ID = 1.0A		1.3	1.7	V
Upper diode forward 2	VD2-2	ID = 2.0A		2.0	2.7	V
Upper diode forward 3	VD2-3	ID = 3.0A		2.7	3.7	V
Hall Amplifier						
Input bias current	IHB		-2	-0.1		μA
Common-mode input voltage range 1	VICM1	Hall device used	0.5		V _{CC} -2.0	V
Common-mode input voltage range 2	VICM2	For input one-side bias (Hall IC application)	0		V _{CC}	V
Hall input sensitivity		at differential input	50			mVp-p
Hysteresis width	ΔV _{IN}		20	30	50	mV
Input voltage low → high	VSLH		5	15	25	mV
Input voltage high → low	VSHL		-25	-15	-5	mV
PWM oscillator						
Output H level voltage	V _{OH} (PWM)		2.75	3.0	3.25	V
Output L level voltage	V _{OL} (PWM)		1.0	1.2	1.3	V
External C charge current	ICHG(PWM)	VPWM = 2.1V	-60	-45	-30	μA
Oscillator frequency	f (PWM)	C = 1000pF	15.8	20	24.2	kHz
Amplitude	V (PWM)		1.6	1.8	2.1	Vp-p
CSD circuit						
Operating voltage	V _{OH} (CSD)		3.6	3.9	4.2	V
External C charge current	ICHG (CSD)	VCSD = 0V	-15	-11	-7	μA
Operating time	T (CSD)	C = 10μF, Design target value*		3.5		s
HP pin						
Output low level voltage	V _{OL} (HP)	IHP = 2mA		0.1	0.4	V
Output leakage current	I _{leak} (HP)	VHP = 30V			10	μA
Thermal shutdown operation						
Thermal shutdown operating temperature	TTSD	Design target value* (junction temperature)	150	180		°C
Hysteresis width	ΔTSD	Design target value* (junction temperature)		45		°C
Current limiter circuit (RF pin)						
Limiter voltage	VRF		0.45	0.5	0.55	V

Note : * This parameter is a design target value and is not measured.

Continued on next page.

LB11920

Continued from preceding page.

Parameter	Symbol	Conditions	Ratings			Unit
			min	typ	max	
Low-voltage protection circuit						
Operating voltage	VSDL		3.6	3.8	4.0	V
Release voltage	VSDH		4.1	4.3	4.5	V
Hysteresis width	ΔVSD		0.35	0.5	0.65	V
PWMIN pin						
Input frequency	f (PI)				50	kHz
H level input voltage	V_{IH} (PI)		2.0		V_{CC}	V
L level input voltage	V_{IL} (PI)		0		1.0	V
Input open voltage	V_{IO} (PI)		$V_{CC}-0.5$		V_{CC}	V
Hysteresis width	V_{IS} (PI)		0.15	0.25	0.35	V
H level input current	I_{IH} (PI)	$VPWMIN = V_{CC}$	-10	0	10	μA
L level input current	I_{IL} (PI)	$VPWMIN = 0V$	-116	-87	-58	μA
S/S pin						
H level input voltage	V_{IH} (S/S)		2.0		V_{CC}	V
L level input voltage	V_{IL} (S/S)		0		1.0	V
Input open voltage	V_{IO} (S/S)		$V_{CC}-0.5$		V_{CC}	V
Hysteresis width	V_{IS} (S/S)		0.15	0.25	0.35	V
H level input current	I_{IH} (S/S)	$VS/S = V_{CC}$	-10	0	10	μA
L level input current	I_{IL} (S/S)	$VS/S = 0V$	-116	-87	-58	μA
F/R pin						
H level input voltage	V_{IH} (F/R)		2.0		V_{CC}	V
L level input voltage	V_{IL} (F/R)		0		1.0	V
Input open voltage	V_{IO} (F/R)		$V_{CC}-0.5$		V_{CC}	V
Hysteresis width	V_{IS} (F/R)		0.15	0.25	0.35	V
H level input current	I_{IH} (F/R)	$VF/R = V_{CC}$	-10	0	10	μA
L level input current	I_{IL} (F/R)	$VF/R = 0V$	-116	-87	-58	μA
BR pin						
H level input voltage	V_{IH} (BR)		2.0		V_{CC}	V
L level input voltage	V_{IL} (BR)		0		1.0	V
Input open voltage	V_{IO} (BR)		$V_{CC}-0.5$		V_{CC}	V
Hysteresis width	V_{IS} (BR)		0.15	0.25	0.35	V
H level input current	I_{IH} (BR)	$VBR = V_{CC}$	-10	0	10	μA
L level input current	I_{IL} (BR)	$VBR = 0V$	-116	-87	-58	μA

Package Dimensions

unit : mm (typ)

3174C

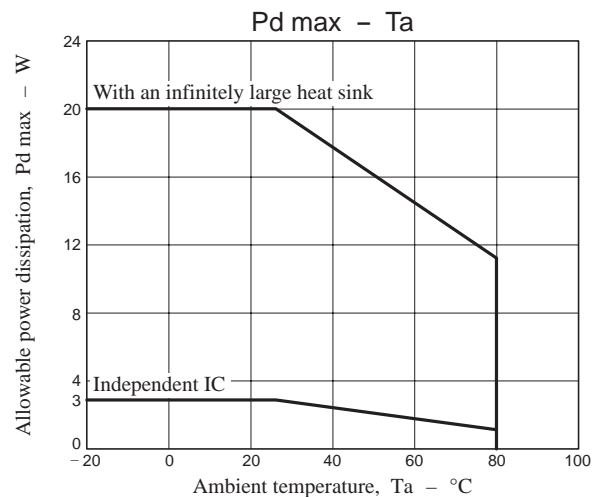
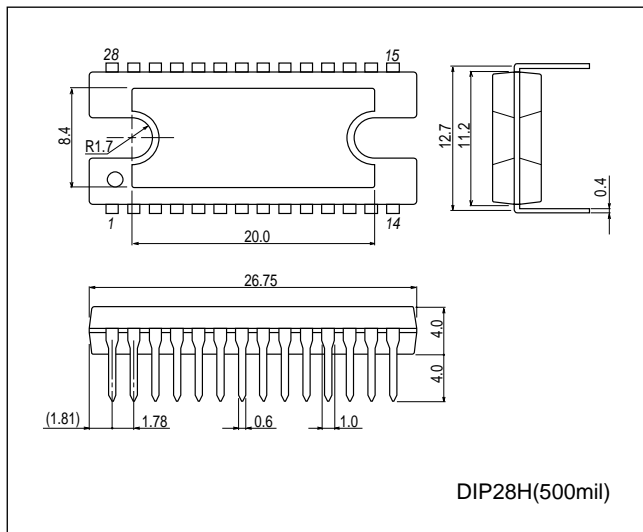

LB11920

Pin Assignment

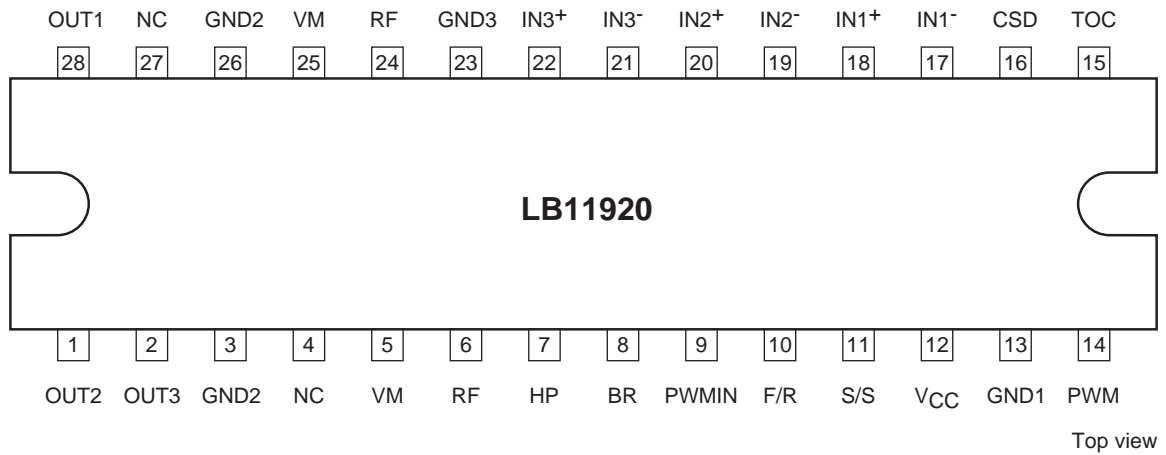

Truth Table

	Source	Sink	F/R = "L"			F/R = "H"		
			IN1	IN2	IN3	IN1	IN2	IN3
1	OUT2 → OUT1		H	L	H	L	H	L
2	OUT3 → OUT1		H	L	L	L	H	H
3	OUT3 → OUT2		H	H	L	L	L	H
4	OUT1 → OUT2		L	H	L	H	L	H
5	OUT1 → OUT3		L	H	H	H	L	L
6	OUT2 → OUT3		L	L	H	H	H	L

S/S pin

Input condition	Condition
H or open	Stop
L	Start

PWMIN pin

Input condition	Condition
H or open	Output OFF
L	Output O

BR pin

Input condition	Condition
H or open	-
L	Brake

The PWMIN pin must be held at the low-level voltage when this IC is operated with a voltage applied to the TOC pin.

Block Diagram

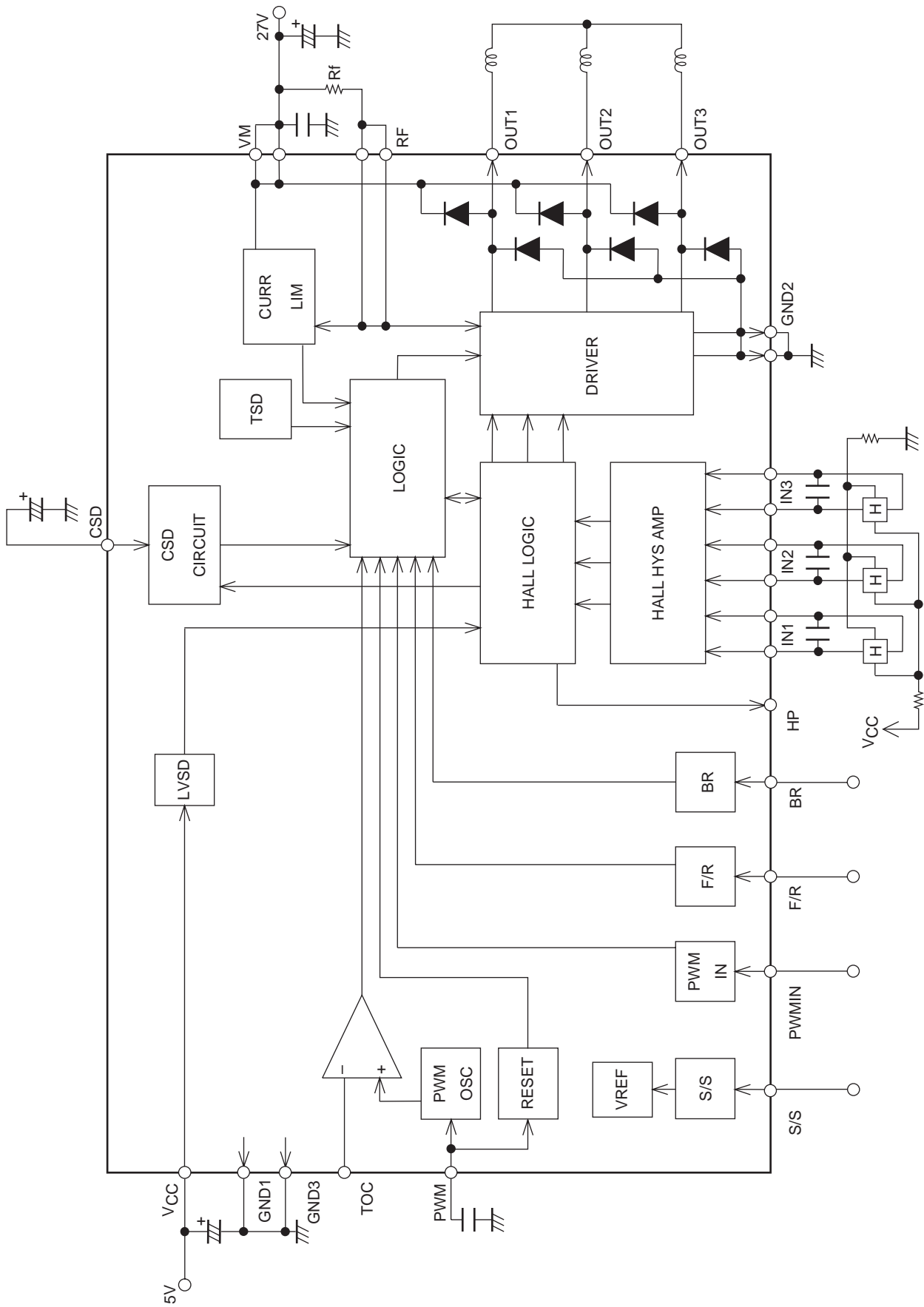

LB11920

Pin Functions

Pin No.	Pin name	Function	Equivalent circuit
28 1 2	OUT1 OUT2 OUT3	Motor drive output pin.	
3, 26	GND2	Output GND pin.	
5, 25	VM	Power pin.	
6, 24	RF	Output Tr power and output current detector pins, which connect low resistance (Rf) to VM. The output current is limited to the current value set with $I_{OUT} = V_{RF}/R_f$.	
7	HP	Hall element signal three-phase composite output. Withstand voltage 35V max.	
8	BR	Brake input pin. "L" for brake and "H" or open for normal rotation.	
9	PWMIN	PWM pulse input pin. L for output drive and H or open for output OFF.	
10	F/R	Forward/reverse input pin.	

Continued on next page.

LB11920

Continued from preceding page.

Pin No.	Pin name	Function	Equivalent circuit
11	S/S	Start/stop control pin. Start with L and stop with H or in the open condition.	
12	VCC	Control circuit power pin.	
13	GND1	GND pin (control circuit block).	
14	PWM	Pin to set the PWM oscillation frequency. Connect a capacitor between this pin and GND.	
15	TOC	PWM waveform comparator pin. Normally use with "L" or open. To control the output duty by applying the voltage to this pin without using the PWMIN pin, set the PWMIN pin to "L".	
16	CSD	Pin to set the operation time of motor lock protection circuit. Insertion of a capacitor (about 10μF) between CSD and GND enables setting of the protection operation time of about 3.5sec.	

Continued on next page.

LB11920

Continued from preceding page.

Pin No.	Pin name	Function	Equivalent circuit
18 17 20 19 22 21	IN1+ IN1- IN2+ IN2- IN3+ IN3-	Hall amplifier input. IN+ > IN- is the input high state, and the reverse is the input low state. Connect a capacitor between the IN+ and IN- inputs if there is noise in the Hall sensor signals.	
23	GND3	SUBGND pin to connect to GND1 that is GND of the control circuit.	
4 27	NC	NC pin that can be used for wiring.	

LB11920 Description

1. Output drive circuit

This IC is of a direct PWM drive type that suffers less power loss at the output.

On the basis of the signal (“H” level for OFF and “L” level for ON) entered in the PWMIN pin, the lower output Tr performs PWM switching, causing change in the motor drive power.

To control by means of the DC voltage, apply the voltage to the TOC pin (in this case, the PWMIN pin should be in the “L” level input condition). The TOC pin voltage is compared with the oscillation voltage of PWM pin, determining the duty. As the TOC pin voltage is lower, the output duty increases.

2. Hall input signal

For Hall input, entry of the signal whose amplitude is larger than the hysteresis width (50mV max) is necessary.

Considering effects of noise and phase delay, entry of the amplitude of 120mVp-p (at differential input) or more is recommended.

When noise causes disturbance in the output waveform (at phase switching) or in the HP output (Hall signal three-phase composite output), insert a capacitor, etc. as near as possible to the pin between inputs to prevent such effects.

The Hall input is used as a signal for judgment of the input of the motor lock protection circuit. Though it is designed to ignore noise to a certain extent, due attention should be paid to check for incorrect operation of the protection circuit. Both upper and lower outputs are OFF when all three-phases of Hall input signal are in the common-mode input condition.

When the Hall IC output is to be entered, entry of 0 - V_{CC} can be made for another single-side input by fixing either one side (+ or -) of input to the voltage within the common-mode input range with the Hall element used.

3. Current limiting circuit

The current limiting circuit performs limiting with the current determined from $I = V_{RF}/R_f$ ($V_{RF} = 0.5V_{typ}$, R_f : current detector resistance) (that is, this circuit limits the peak current).

The control operation functions to reduce the on state duty of the output and thus reduce the current.

Switching during current limiting is made on the basis of the frequency oscillated with the PWM pin.

The PWM frequency is determined from the capacitance C (F) of capacitor connected to the PWM pin.

$$f_{PWM} \approx 1 / (50000 \times C)$$

The PWM frequency of 15k to 25kHz is recommended. As PWM oscillation is used also as a clock signal of the internal logic circuit, its oscillation is necessary even in the application where current limiting is not needed.

4. Power save circuit

This IC enters the power save condition to decrease the current dissipation in the stop mode. In this condition, the bias current of most of circuits is cut off.

5. Forward/backward changeover

The motor rotation can be changed over with the F/R pin. Following cautions should be observed when F/R changeover is to be made while the motor is running :

- The circuit incorporates a measure against the through current at a time of changeover. However it is necessary to take an appropriate measure to prevent the voltage from exceeding the rated voltage (35V) because of rising of the VM voltage at changeover (instantaneous return of the motor current to the power supply). When this is a problem, increase the capacitance of a capacitor between VM and GND.
- When the motor current after changeover is the current limit or more, the lower Tr is turned OFF. But the upper Tr enters the short-brake condition, and the current determined from the motor counter-electromotive voltage and coil resistance flows. It is necessary to prevent this current from exceeding the rated current (3.5A). (F/R changeover at high rotation speed is dangerous.)

6. Brake operation

Brake operation is made through setting of the BR pin to the “L” level. This operation consists of a short-brake operation in which all of lower outputs are turned OFF while all of upper outputs are turned ON. While the brake is operating, current limiting and motor lock protection circuits are not operative. Apply brake only when the current during operation does not exceed the rated current (3.5A).

The circuit incorporates a measure against the through current at a time of changeover. However it is necessary to take an appropriate measure to prevent the voltage from exceeding the rated voltage (35V) because of rising of the VM voltage at changeover (instantaneous return of the motor current to the power supply). When this is a problem, increase the capacitance of a capacitor between VM and GND.

7. Motor lock protection circuit

A motor lock protection circuit is incorporated for protection of IC and motor when the motor is locked.

The lower output Tr is turned OFF when the Hall input signal is not switched for a certain period in the motor drive condition.

The time is set by means of a capacity of a capacitor connected to the CSD pin.

Time setting of about 3.5sec is possible for the capacitance of 10 μ F. (Variance \pm 30%)

$$\text{Set time (s)} \approx 0.35 \times C (\mu\text{F})$$

Due care must be taken on any leakage current in the capacitor used because it may adversely affect error of the set time, etc.

To cancel the motor lock protection condition, one of following steps must be taken :

- Stop mode
- Maintaining the output duty 0% condition through input of PWMIN or TOC for more than the period of $t_{\text{PWM}} \times 8$. (t_{PWM} : IC internal PWM oscillation period)
- Power must be applied again (in the stop condition).

Connect the CSD pin to GND when the motor lock protection circuit is not to be used.

The motor lock protection active period at restart becomes shorter than the setting when the stop time to cancel motor lock protection is shorter because the charge of capacitor cannot be fully discharged. Therefore, it is necessary to provide a certain allowance to the stop period while referring to the following formula as a guideline.

$$\text{Stop time (ms)} \geq 15 \times C (\mu\text{F})$$

8. Circuit for low-voltage protection

This circuit detects the voltage applied to the V_{CC} pin. When this voltage drops below the operation voltage (see the electric characteristics), the lower side output is turned OFF. To prevent repetition of output ON/OFF near the protection activation voltage, the hysteresis is provided. Accordingly, the output is not recovered unless the voltage rises by about 0.5V above the activation voltage.

9. HP output

For the HP output, the composite signal of three phases of Hall element signal is output. This is an open collector output. This can be used for the motor rotation detection signal, etc.

10. Power supply stabilization

This IC has a large output current, which causes deviation of the power line readily. To ensure stability, it is necessary to insert a capacitor with sufficient capacitance between the VM pin and GND. To eliminate the high-frequency noise due to switching, insert a ceramic capacitor of about 0.1 μ F as near as possible to the pin between VM (pin 5) and GND 2 (pin 3).

When inserting diode in the power line to prevent breakdown due to reverse connection of power supply, select the sufficiently large capacitance because the power line tends to develop deviation readily.

The V_{CC} voltage that is a control power supply must also be fully stabilized by means of a capacitor when such voltage tends to fluctuate because of routing.

11. Routing of a printed circuit board

Two pins are provided for each of VM, RF, and GND2 pins where large current flows. On the printed circuit board, both of these pins should be connected and used. If the use of only one pin is possible in certain cases, use pins 3, 5, and 6.

GND3 that is a sub-GND (internal separation layer) should be connected with control GND or GND1 with the shortest possible wiring.

ON Semiconductor and the ON logo are registered trademarks of Semiconductor Components Industries, LLC (SCILLC). SCILLC owns the rights to a number of patents, trademarks, copyrights, trade secrets, and other intellectual property. A listing of SCILLC's product/patent coverage may be accessed at www.onsemi.com/site/pdf/Patent-Marking.pdf. SCILLC reserves the right to make changes without further notice to any products herein. SCILLC makes no warranty, representation or guarantee regarding the suitability of its products for any particular purpose, nor does SCILLC assume any liability arising out of the application or use of any product or circuit, and specifically disclaims any and all liability, including without limitation special, consequential or incidental damages. "Typical" parameters which may be provided in SCILLC data sheets and/or specifications can and do vary in different applications and actual performance may vary over time. All operating parameters, including "Typicals" must be validated for each customer application by customer's technical experts. SCILLC does not convey any license under its patent rights nor the rights of others. SCILLC products are not designed, intended, or authorized for use as components in systems intended for surgical implant into the body, or other applications intended to support or sustain life, or for any other application in which the failure of the SCILLC product could create a situation where personal injury or death may occur. Should Buyer purchase or use SCILLC products for any such unintended or unauthorized application, Buyer shall indemnify and hold SCILLC and its officers, employees, subsidiaries, affiliates, and distributors harmless against all claims, costs, damages, and expenses, and reasonable attorney fees arising out of, directly or indirectly, any claim of personal injury or death associated with such unintended or unauthorized use, even if such claim alleges that SCILLC was negligent regarding the design or manufacture of the part. SCILLC is an Equal Opportunity/Affirmative Action Employer. This literature is subject to all applicable copyright laws and is not for resale in any manner.