



PA3011

CMOS IC

3-W STEREO AUDIO POWER AMPLIFIER WITH ADVANCED DC VOLUME CONTROL

DESCRIPTION

As a stereo audio speaker which is operating on a single 5.5V supply, the UTC **PA3011** is capable of delivering 3W of output power per channel into 3Ω loads with less than 10% THD+N.

The speaker volume level is adjusted by applying a dc voltage to the VOLUME terminal. When a dc voltage is applied, to avoid an unexpected high volume level through the headphones, a third terminal, SEMAX, limits the headphone volume level. And also a fade mode ramps the volume up and down to ensure a smooth transition between active and shutdown modes,.

The UTC **PA3011** can be applicatated in notebook, LCD monitors and pocket PC.

FEATURES

- * DC volume control with 2-dB steps :-40 dB ~ 20 dB
- * Fade mode
- * Maximum volume setting for SE mode
- * 3 W into 3Ω load
- * MUX stereo input

ORDERING INFORMATION

Ordering Number	Package	Packing
PA3011G-N24-R	HTSSOP-24	Tape Reel

<p>PA3011G-N24-R</p> <ul style="list-style-type: none"> (1) Packing Type (2) Package Type (3) Green Package 	<ul style="list-style-type: none"> (1) R: Tape Reel (2) N24: HTSSOP-24 (3) G: Halogen Free and Lead Free
--	---

MARKING

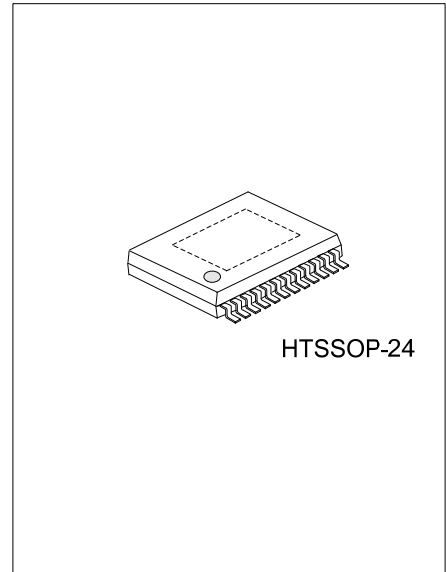
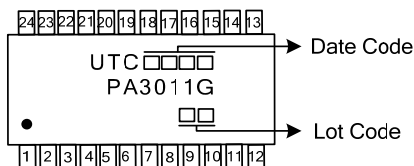

HTSSOP-24

■ PIN CONFIGURATION

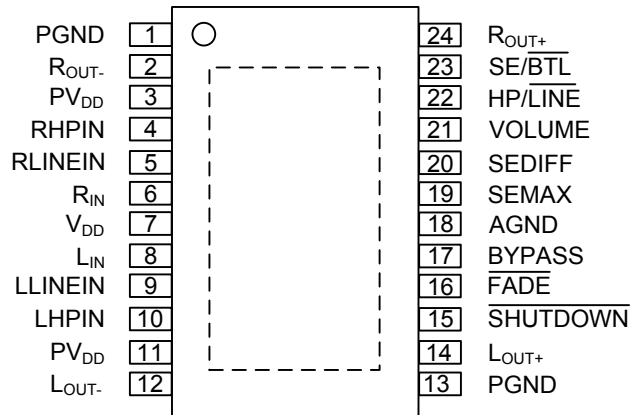

■ PIN DESCRIPTION

PIN #	PIN NAME	I/O	DESCRIPTION
1,13	PGND		Ground, directly connected to thermal pad.
12	L _{OUT-}	O	negative output for left channel
3,11	PV _{DD}		Supply voltage
10	LHPIN	I	Left channel headphone input, selected when HP/ LINE pin is held high.
9	LLINEIN	I	Line input for left channel, selected when HP/ LINE pin is held low.
8	L _{IN}	I	Differential input for left channel. AC ground for single-ended inputs.
7	V _{DD}		Analog V _{DD} supply voltage
6	R _{IN}	I	Differential input for right channel. AC ground for single-ended inputs.
5	RLINEIN	I	Line input for Right channel, selected when HP/ LINE pin is held low.
4	RHPIN	I	Right channel headphone input, selected when HP/ LINE pin is held high.
2	R _{OUT-}	O	Negative output for right channel.
24	R _{OUT+}	O	Positive output for right channel.
15	SHUTDOWN	I	Circuit is in shutdown mode when this pin is held low.
16	FADE	I	If a logic low is placed on this terminal places the amplifier in fade mode; if a logic high is placed on this terminal normal operation
17	BYPASS	I	Tap to voltage divider for internal midsupply bias generator
18	AGND		Analog ground
19	SEMAX	I	This sets the maximum volume for single ended operation. The DC voltage range is 0 to V _{DD} .
20	SEDIFF	I	This sets the difference between BTL volume and SE volume. The DC voltage range is 0 to V _{DD} .
21	VOLUME	I	DC volume control. The DC voltage range is 0 to V _{DD} .
22	HP/LINE	I	MUX control input, hold high to select headphone inputs, hold low to select line inputs.
23	SE/BTL	I	Hold low for BTL mode, hold high for SE mode.
14	L _{OUT+}	O	Positive output for left channel.

■ ABSUTE MAXIMUM RATINGS (T_A=25°C)

PARAMETER	SYMBOL	RATINGS	UNIT
Supply Voltage, V _{DD} , PV _{DD}	V _{SS}	-0.3V ~ 6V	V
Input Voltage	V _{IN}	-0.3 V ~ V _{DD} +0.3V	V
Junction Temperature	T _J	-40 ~ +150	°C
Operating Temperature	T _{OPR}	-40 ~ +85	°C
Storage Temperature Range	T _{STG}	-65 ~ +150	°C

Note: Absolute maximum ratings are those values beyond which the device could be permanently damaged. Absolute maximum ratings are stress ratings only and functional device operation is not implied.

■ ELECTRICAL CHARACTERISTICS (T_A=25°C, unless otherwise specified)

PARAMETER	SYMBOL	CONDITIONS	MIN	TYP	MAX	UNIT
DC CHARACTERISTICS (V_{DD}=PV_{DD}=5.5V)						
Supply voltage	V _{DD}		4.0		5.5	V
High-level Input Voltage	V _{IH}	SE/BTL, HP/LINE, FADE SHUTDOWN	0.8×V _{DD} 2			V
Low-level Input Voltage	V _{IL}	SE/BTL, HP/LINE, FADE SHUTDOWN			0.6×V _{DD} 0.8	V
High-level Input Current (SE/BTL, FADE, HP/LINE, SHUTDOWN, SEDIFF, SEMAX, VOLUME)	I _{IH}	V _{IN} =V _{DD} =PV _{DD}			1	μA
Low-level Input Current (SE/BTL, FADE, HP/LINE, SHUTDOWN, SEDIFF, SEMAX, VOLUME)	I _{IL}	V _{IN} =0V			1	μA
Supply Current, No Load	I _{DD}	SE/BTL=0V, SHUTDOWN=2V	6.0	7.5	9.0	mA
		SE/BTL=5.5V, SHUTDOWN=2V	3.0	5	6	
Supply Current, Shutdown Mode	I _{DD(SD)}	SHUTDOWN=0V		1	20	μA
DC Differential Output Voltage	V _{OUT(DIFF)}	Gain=0dB, SE/BTL=0V			30	mV
		Gain=20dB, SE/BTL=0V			50	
AC CHARACTERISTICS (V_{DD}=PV_{DD}=5V, R_L=3Ω, Gain=6dB)						
Bypass Voltage (Nominally V _{DD} /2)	V _(BYPASS)	Measured At Pin17, No Load	2.65	2.75	2.85	V
High-Level Output Voltage	V _{OH}	R _L =8Ω, Measured Between Output And V _{DD}			700	mV
Low-Level Output Voltage	V _{OL}	R _L =8Ω, Measured Between Output And GND			400	mV
Output Power	P _{OUT}	THD=1%, f=1kHz		2		W
		THD=10%, f=1kHz, V _{DD} =5.5V		3		
Total Harmonic Distortion + Noise	THD+N	P _{OUT} =1W, R _L =8Ω, f=20Hz~20kHz		<0.4%		
Maximum Output Power Bandwidth	B _{OM}	THD=5%		>20		kHz
Power Supply Rejection Ratio	PSRR	V _{DD} =PV _{DD} =4.0V~5.5V	-42	-70		dB
Supply Ripple Rejection Ratio	RR	f=1kHz, Gain=0dB, C _(BYP) =0.4μF	BTL		-63	dB
			SE		-57	
Noise Output Voltage	eN	Gain=0dB, C _(BYP) =0.47μF f=20Hz~20kHz		36		μV _{RMS}
Supply Current, Max Power Into a 3-Ω Load	I _{DD}	SHUTDOWN =2V, R _L =3Ω,		1.5		A _{RMS}
		SE/BTL =0V, P _{OUT} =2W				

■ TYPICAL APPLICATION CIRCUIT

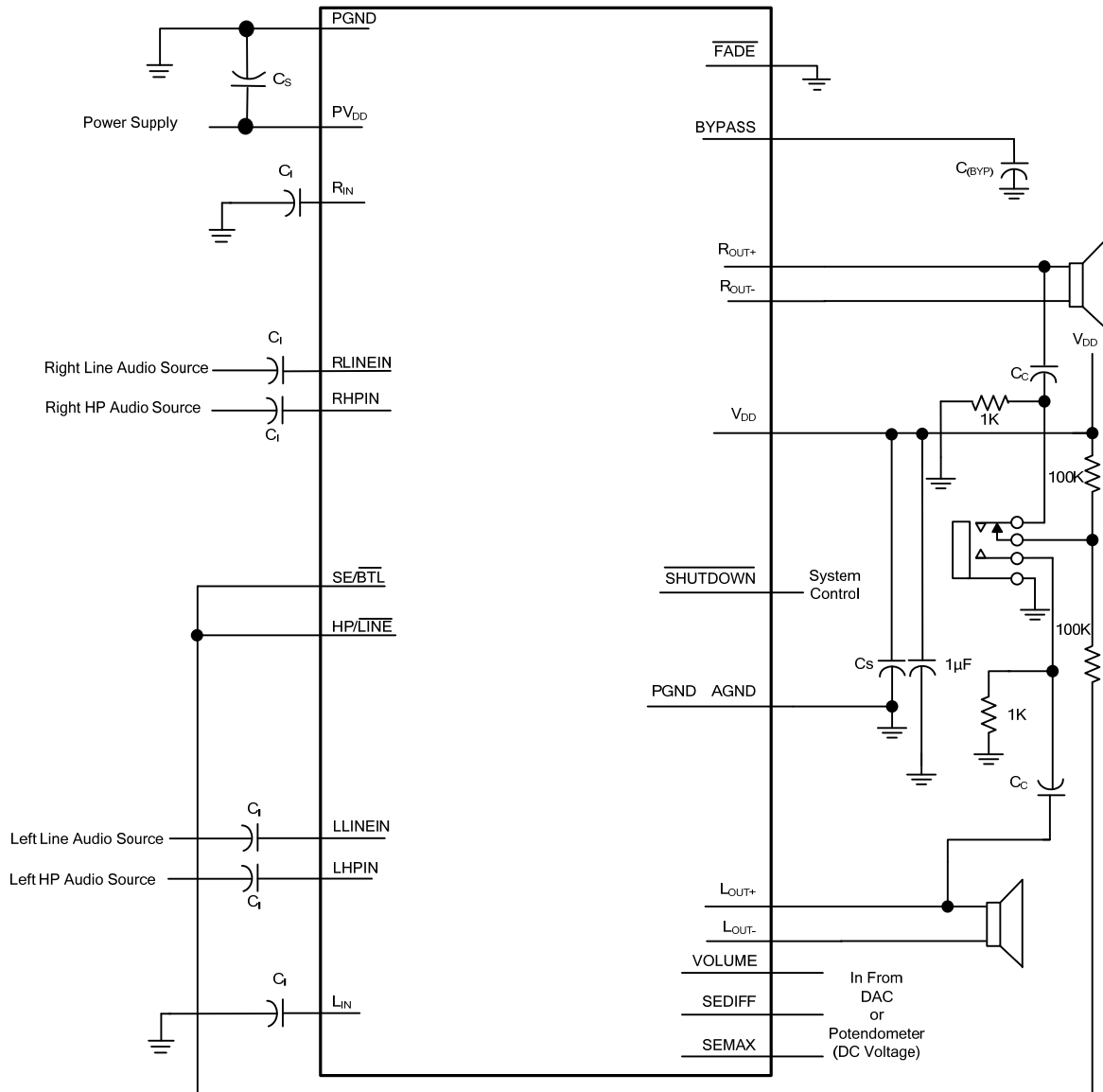

■ BLOCK APPLICATION

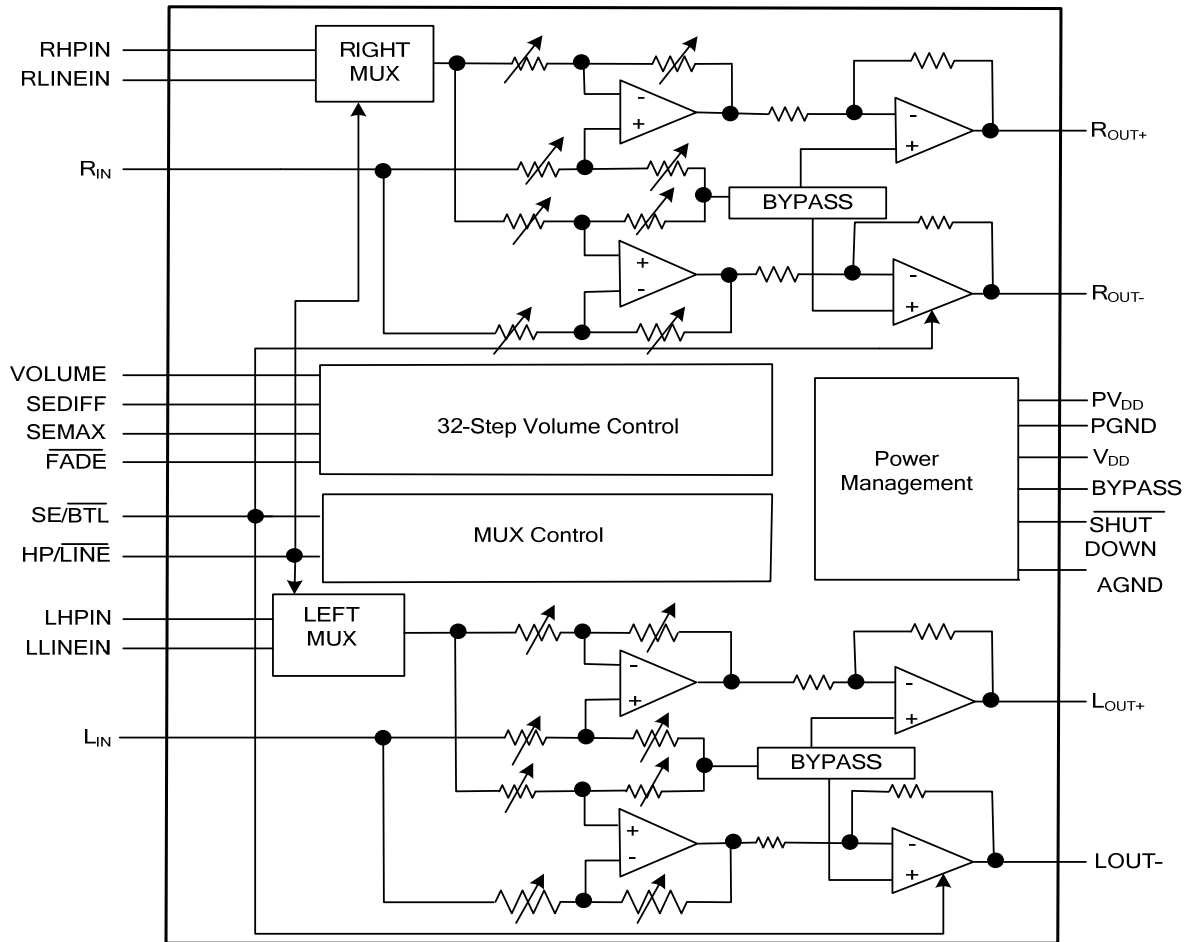

■ VOLUME CONTROL TABLE

BTL Mode, V _{DD} =5V(Note 1)			SE Mode V _{DD} =5V(Note 1)		
VOLUME (PIN21)		GAIN OF AMPLIFIER (TYP)	SE_VOLUME=VOLUME – SEDIFF or SEMAX		GAIN OF AMPLIFIER (TYP)
FROM(V)	TO(V)		FROM(V)	TO(V)	
0.00	0.26	-85(Note 2)	0.00	0.26	-85(Note 2)
0.33	0.37	-40	0.33	0.37	-46
0.44	0.48	-38	0.44	0.48	-44
0.58	0.59	-36	0.56	0.59	-42
0.67	0.70	-34	0.67	0.70	-40
0.78	0.82	-32	0.78	0.82	-38
0.89	0.93	-30	0.89	0.93	-36
1.01	1.04	-28	1.01	1.04	-34
1.12	1.06	-26	1.12	1.16	-32
1.23	1.27	-24	1.23	1.27	-30
1.35	1.38	-22	1.35	1.38	-28
1.48	1.49	-20	1.48	1.49	-26
1.57	1.60	-18	1.57	1.60	-24
1.68	1.72	-16	1.68	1.72	-22
1.79	1.83	-14	1.79	1.83	-20
1.91	1.94	-12	1.91	1.94	-18
2.02	2.06	-10	2.02	2.06	-16
2.13	2.17	-8	2.13	2.17	-14
2.25	2.28	-6(Note 2)	2.25	2.28	-12
2.38	2.39	-4	2.36	2.39	-10
2.47	2.50	-2	2.47	2.50	-8
2.58	2.61	0	2.58	2.61	-6(Note 2)
2.70	2.73	2	2.70	2.73	-4
2.81	2.83	4	2.81	2.83	-2
2.92	2.95	6	2.92	2.95	0(Note 2)
3.04	3.06	8	3.04	3.06	2
3.15	3.17	10	3.15	3.17	4
3.28	3.29	12	3.26	3.29	6(Note 2)
3.38	3.40	14	3.38	3.40	8
3.49	3.51	16	3.49	3.51	10
3.60	3.63	18	3.60	3.63	12
3.71	5.00	20(Note 2)	3.71	5.00	14

Note: 1. For other values of V_{DD}, scale the voltage values in the table by a factor of V_{DD}/5.

2. Tested in production. Remaining gain steps are specified by design.

■ TYPICAL CHARACTERISTICS

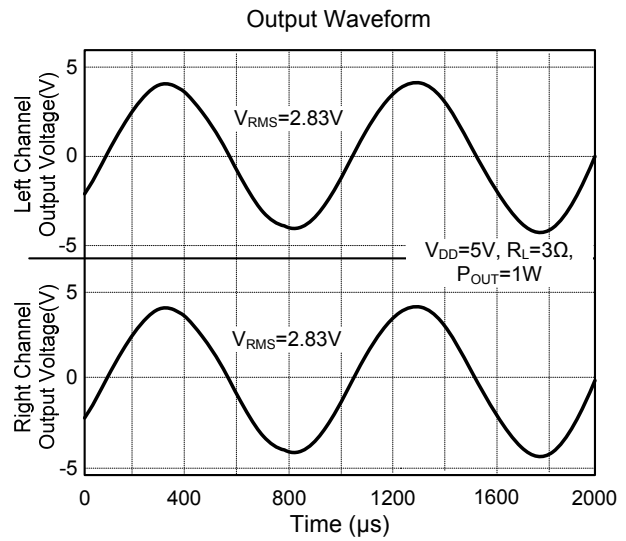
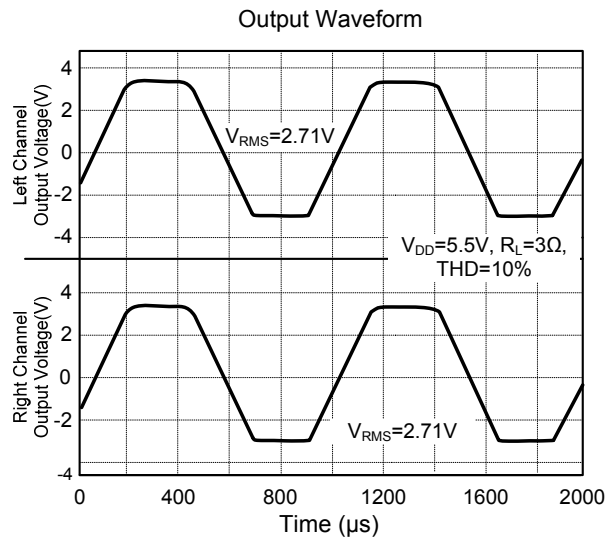

UTC assumes no responsibility for equipment failures that result from using products at values that exceed, even momentarily, rated values (such as maximum ratings, operating condition ranges, or other parameters) listed in products specifications of any and all UTC products described or contained herein. UTC products are not designed for use in life support appliances, devices or systems where malfunction of these products can be reasonably expected to result in personal injury. Reproduction in whole or in part is prohibited without the prior written consent of the copyright owner. The information presented in this document does not form part of any quotation or contract, is believed to be accurate and reliable and may be changed without notice.