

Low-power quad operational amplifier

Datasheet - production data



N
DIP14
(plastic package)



D
SO14
(plastic micropackage)



P
TSSOP14
(thin shrink small outline package)

Pin connections (top view)

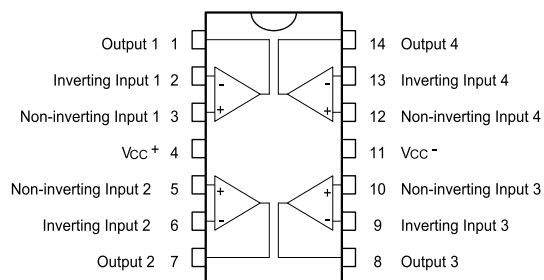

Features

- Wide gain bandwidth: 1.3 MHz
- Input common-mode voltage range includes negative rail
- Large voltage gain: 100 dB
- Very low supply current per amplifier: 375 μ A
- Low input bias current: 20 nA
- Low input offset current: 2 nA
- ESD internal protection: 800 V
- Wide power supply range
- Single supply: +3 V to +30 V
- Dual supplies: \pm 1.5 V to \pm 15 V

Description

This circuit consists of four independent, high-gain, internally frequency-compensated operational amplifiers designed especially for automotive and industrial control systems.

The device operates from a single power supply over a wide range of voltages. Operation from split power supplies is also possible and the low power supply current drain is independent of the magnitude of the power supply voltage.

All the pins are protected against electrostatic discharges up to 800 V.

Contents

1	Absolute maximum ratings and operating conditions	3
2	Circuit schematics	4
3	Electrical characteristics	5
4	Typical single-supply applications	10
5	Macromodel	12
6	Package information	13
6.1	DIP14 package information	13
6.2	SO14 package information	14
6.3	TSSOP14 package information	15
7	Ordering information	16
8	Revision history	17

1 Absolute maximum ratings and operating conditions

Table 1. Absolute maximum ratings

Symbol	Parameter	Value	Unit
V_{CC}	Supply voltage	± 16 to 32	V
V_{id}	Differential input voltage	+32	
V_i	Input voltage	-0.3 to $V_{CC}^+ + 0.3$	
	Output short-circuit to ground ⁽¹⁾	Infinite	
I_{in}	Input current ⁽²⁾	50	mA
T_{stg}	Storage temperature range	-65 to +150	°C
R_{thja}	Thermal resistance junction to ambient ⁽³⁾		°C/W
	DIP14	80	
	SO14	105	
R_{thjc}	Thermal resistance junction to case ⁽³⁾		
	DIP14	33	
	SO14	31	
TSSOP14	32		
ESD	HBM: human body model ⁽⁴⁾	800	V
	MM: machine model ⁽⁵⁾	100	
	CDM: charged device model ⁽⁶⁾	1500	

- Short-circuits from the output to V_{CC}^+ can cause excessive heating and potential destruction. The maximum output current is approximately 20 mA, independent of the magnitude of V_{CC}^+ .
- This input current only exists when the voltage at any of the input leads is driven negative. It is due to the collector-base junction of the input PNP transistor becoming forward biased and thereby acting as an input diode clamp. In addition to this diode action, there is also NPN parasitic action on the IC chip. This transistor action can cause the output voltages of the op-amps to go to the V_{CC} voltage level (or to ground for a large overdrive) for the time during which an input is driven negative. This is not destructive and normal output is restored for input voltages higher than -0.3 V.
- $R_{thja/c}$ are typical values.
- Human body model: a 100 pF capacitor is charged to the specified voltage, then discharged through a 1.5 k Ω resistor between two pins of the device. This is done for all couples of connected pin combinations while the other pins are floating.
- Machine model: a 200 pF capacitor is charged to the specified voltage, then discharged directly between two pins of the device with no external series resistor (internal resistor < 5 Ω). This is done for all couples of connected pin combinations while the other pins are floating.
- Charged device model: all pins and the package are charged together to the specified voltage and then discharged directly to the ground through only one pin. This is done for all pins.

Table 2. Operating conditions

Symbol	Parameter	Value	Unit
V_{CC}	Supply voltage	3 to 30	V
V_{icm}	Common mode input voltage range $T_{min} \leq T_{amb} \leq T_{max}$	V_{CC}^- to $V_{CC}^+ - 1.5$ V_{CC}^- to $V_{CC}^+ - 2$	
T_{oper}	Operating free-air temperature range	-40 to +125	°C

2 Circuit schematics

Figure 1. Schematic diagram (1/4 LM2902W)

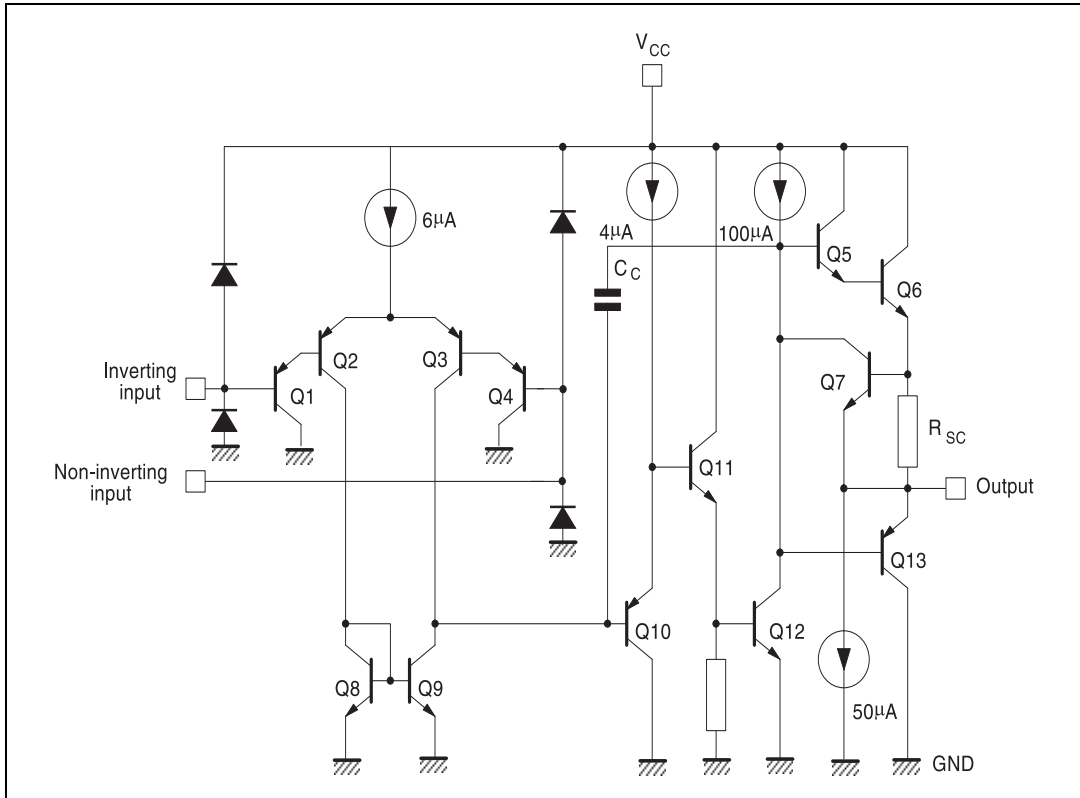

3 Electrical characteristics

Table 3. $V_{CC}^+ = 5\text{ V}$, $V_{CC}^- = \text{ground}$, $V_O = 1.4\text{ V}$, $T_{\text{amb}} = 25\text{ }^\circ\text{C}$
(unless otherwise stated)

Symbol	Parameter	Test conditions	Min.	Typ.	Max.	Unit
V_{io}	Input offset voltage (1)	LM2902W LM2902AW		2	7 2	mV
		$T_{\text{min}} \leq T_{\text{amb}} \leq T_{\text{max}}$ LM2902W $T_{\text{min}} \leq T_{\text{amb}} \leq T_{\text{max}}$ LM2902AW			9 4	
$\Delta V_{io}/\Delta T$	Input offset voltage drift			7	30	$\mu\text{V}/^\circ\text{C}$
I_{io}	Input offset current	$T_{\text{amb}} = +25\text{ }^\circ\text{C}$		2	30	nA
		$T_{\text{min}} \leq T_{\text{amb}} \leq T_{\text{max}}$			40	
DI_{io}	Input offset current drift			10	200	$\text{pA}/^\circ\text{C}$
I_{ib}	Input bias current(2)	$T_{\text{amb}} = +25\text{ }^\circ\text{C}$		20	150	nA
		$T_{\text{min}} \leq T_{\text{amb}} \leq T_{\text{max}}$			300	
A_{vd}	Large signal voltage gain	$V_{CC}^+ = +15\text{ V}$, $R_L = 2\text{ k}\Omega$, $V_O = 1.4\text{ V to } 11.4\text{ V}$, $T_{\text{amb}} = +25\text{ }^\circ\text{C}$	50	100		V/mV
		$V_{CC}^+ = +15\text{ V}$, $R_L = 2\text{ k}\Omega$, $V_O = 1.4\text{ V to } 11.4\text{ V}$, $T_{\text{min}} \leq T_{\text{amb}} \leq T_{\text{max}}$	25			
SVR	Supply voltage rejection ratio	$R_S \leq 10\text{ k}\Omega$, $T_{\text{amb}} = +25\text{ }^\circ\text{C}$	65	110		dB
		$R_S \leq 10\text{ k}\Omega$, $T_{\text{min}} \leq T_{\text{amb}} \leq T_{\text{max}}$	65			
I_{CC}	Supply current (all op-amps, no load)	$T_{\text{amb}} = +25\text{ }^\circ\text{C}$, $V_{CC}^+ = +5\text{ V}$		0.7	1.2	mA
		$T_{\text{amb}} = +25\text{ }^\circ\text{C}$, $V_{CC}^+ = +30\text{ V}$		1.5	3	
		$T_{\text{min}} \leq T_{\text{amb}} \leq T_{\text{max}}$, $V_{CC}^+ = +5\text{ V}$		0.9	1.2	
		$T_{\text{min}} \leq T_{\text{amb}} \leq T_{\text{max}}$, $V_{CC}^+ = +30\text{ V}$		1.5	3	
CMR	Common-mode rejection ratio	$R_S \leq 10\text{ k}\Omega$, $T_{\text{amb}} = +25\text{ }^\circ\text{C}$	70	80		dB
		$R_S \leq 10\text{ k}\Omega$, $T_{\text{min}} \leq T_{\text{amb}} \leq T_{\text{max}}$	60			
I_o	Output short-circuit current	$V_{id} = +1\text{ V}$, $V_{CC}^+ = +15\text{ V}$, $V_O = +2\text{ V}$	20	40	70	mA
I_{sink}	Output sink current	$V_{id} = -1\text{ V}$, $V_{CC}^+ = +15\text{ V}$, $V_O = +2\text{ V}$	10	20		
		$V_{id} = -1\text{ V}$, $V_{CC}^+ = +15\text{ V}$, $V_O = +0.2\text{ V}$	12	50		μA
V_{OH}	High level output voltage	$V_{CC}^+ = 30\text{ V}$, $R_L = 2\text{ k}\Omega$: $T_{\text{amb}} = +25\text{ }^\circ\text{C}$ $T_{\text{min}} \leq T_{\text{amb}} \leq T_{\text{max}}$	26 26	27		V
		$V_{CC}^+ = 30\text{ V}$, $R_L = 10\text{ k}\Omega$: $T_{\text{amb}} = +25\text{ }^\circ\text{C}$, $T_{\text{min}} \leq T_{\text{amb}} \leq T_{\text{max}}$	27 27	28		
		$V_{CC}^+ = 5\text{ V}$, $R_L = 2\text{ k}\Omega$: $T_{\text{amb}} = +25\text{ }^\circ\text{C}$ $T_{\text{min}} \leq T_{\text{amb}} \leq T_{\text{max}}$	3.5 3			

**Table 3. $V_{CC+} = 5\text{ V}$, $V_{CC-} = \text{ground}$, $V_O = 1.4\text{ V}$, $T_{\text{amb}} = 25\text{ }^\circ\text{C}$
(unless otherwise stated) (continued)**

Symbol	Parameter	Test conditions	Min.	Typ.	Max.	Unit
V_{OL}	Low level output voltage	$R_L = 10\text{ k}\Omega$, $T_{\text{amb}} = +25\text{ }^\circ\text{C}$		5	20	mV
		$R_L = 10\text{ k}\Omega$, $T_{\text{min}} \leq T_{\text{amb}} \leq T_{\text{max}}$			20	
SR	Slew rate	$V_{CC+} = 15\text{ V}$, $V_{\text{in}} = 0.5\text{ to }3\text{ V}$, $R_L = 2\text{ k}\Omega$, $C_L = 100\text{ pF}$, unity gain $T_{\text{min}} < T_{\text{op}} < T_{\text{max}}$	0.24 0.14	0.4		V/ μs
GBP	Gain bandwidth product	$V_{CC+} = 30\text{ V}$, $V_{\text{in}} = 10\text{ mV}$, $R_L = 2\text{ k}\Omega$, $C_L = 100\text{ pF}$		1.3		MHz
THD	Total harmonic distortion	$f = 1\text{ kHz}$, $A_V = 20\text{ dB}$, $R_L = 2\text{ k}\Omega$, $V_o = 2\text{ V}_{\text{pp}}$, $C_L = 100\text{ pF}$, $V_{CC+} = 30\text{ V}$		0.015		%
e_n	Equivalent input noise voltage	$f = 1\text{ kHz}$, $R_S = 100\text{ }\Omega$, $V_{CC+} = 30\text{ V}$		40		nV/ $\sqrt{\text{Hz}}$
V_{O1}/V_{O2}	Channel separation ⁽³⁾	$1\text{ kHz} \leq f \leq 20\text{ kHz}$		120		dB

- $V_O = 1.4\text{ V}$, $R_S = 0\text{ }\Omega$, $5\text{ V} < V_{CC+} < 30\text{ V}$, $0\text{ V} < V_{\text{ic}} < V_{CC+} - 1.5\text{ V}$.
- The direction of the input current is out of the IC. This current is essentially constant, independent of the state of the output, so there is no change in the load on the input lines.
- Due to the proximity of external components, ensure that stray capacitance does not cause coupling between these external parts. Typically, this can be detected as this type of capacitance increases at higher frequencies.

Figure 2. Input bias current vs. T_{amb}

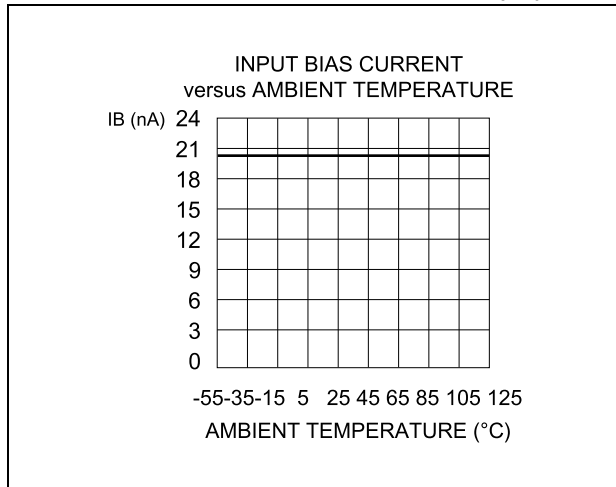

Figure 3. Input voltage range

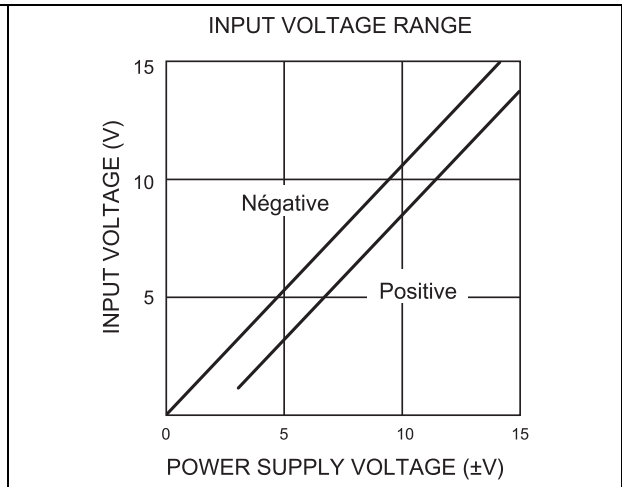

Figure 4. Current limiting

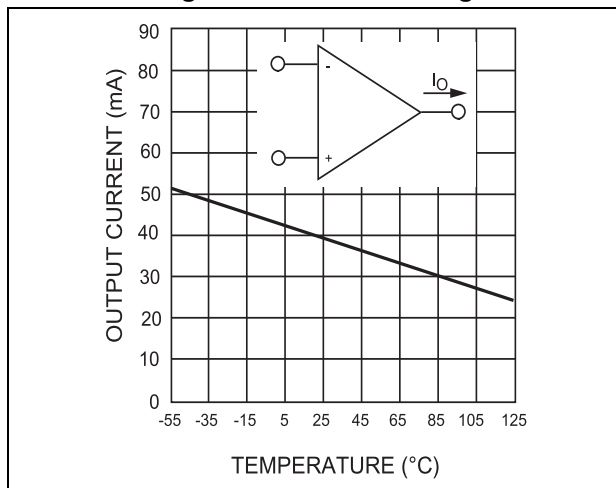

Figure 5. Supply current

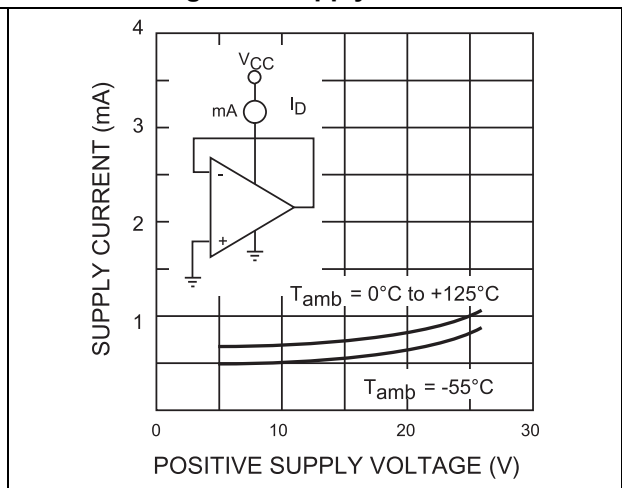

Figure 6. Gain bandwidth product

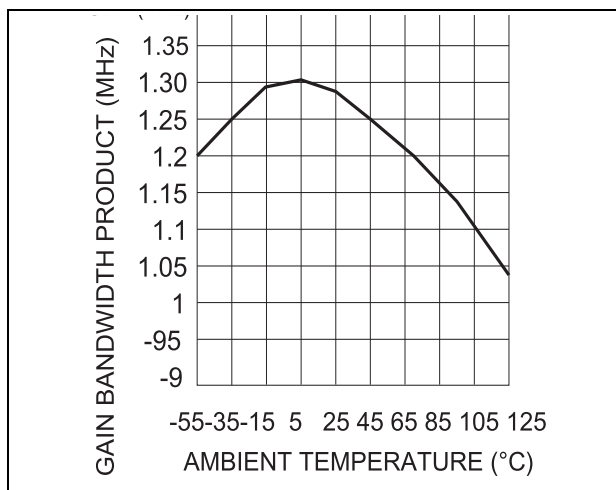

Figure 7. Voltage follower pulse response ($V_{CC} = 15\text{ V}$)

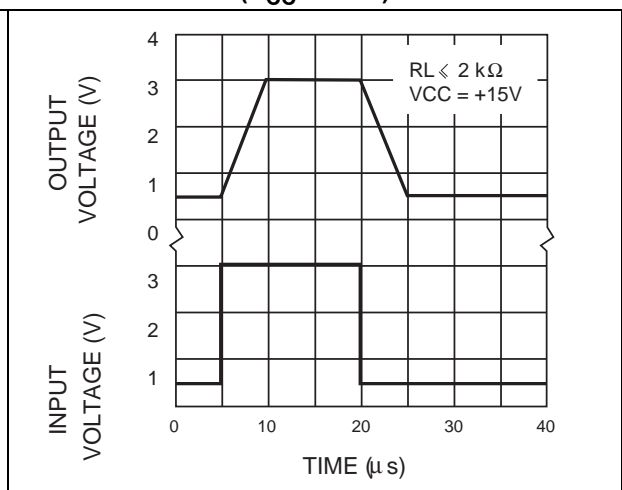

Figure 8. Common-mode rejection ratio

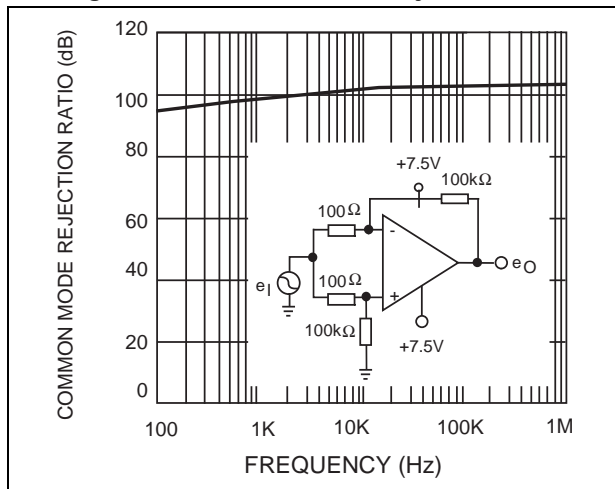

Figure 9. Output characteristics (sink)

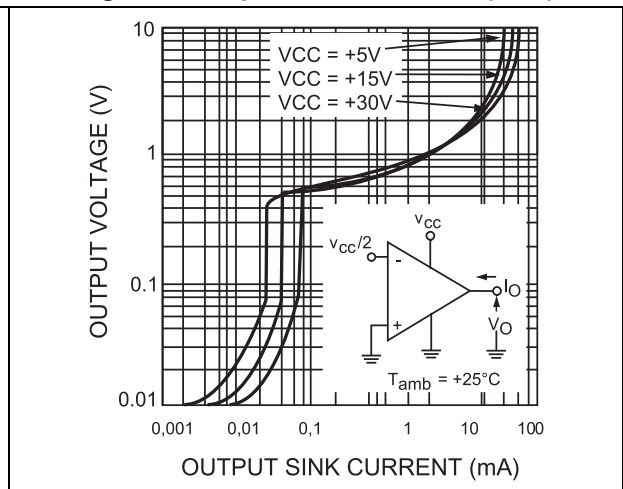

Figure 10. Open-loop frequency response

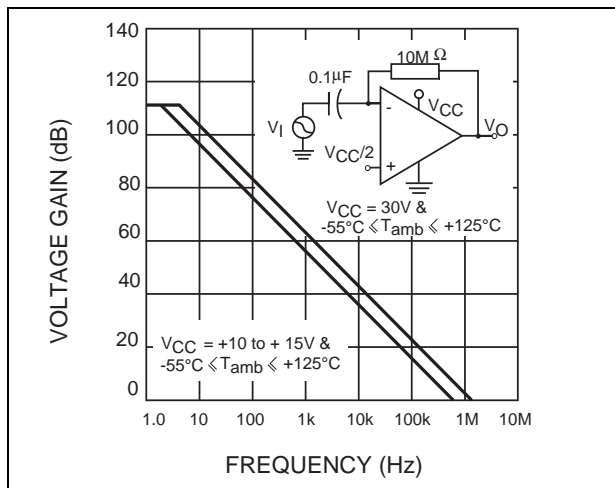

Figure 11. Voltage follower pulse response (VCC = 30 V)

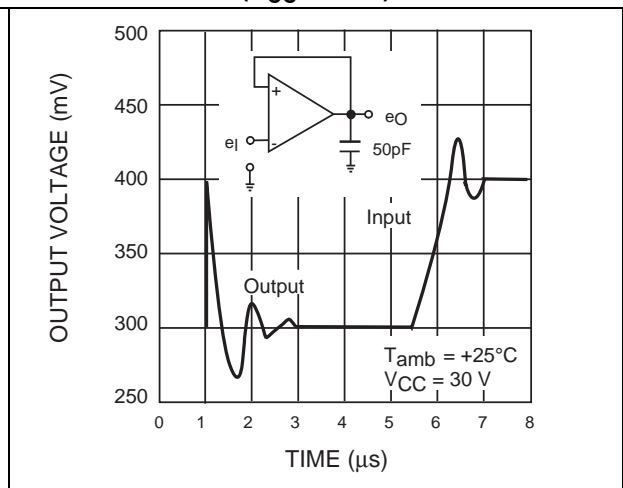

Figure 12. Large signal frequency response

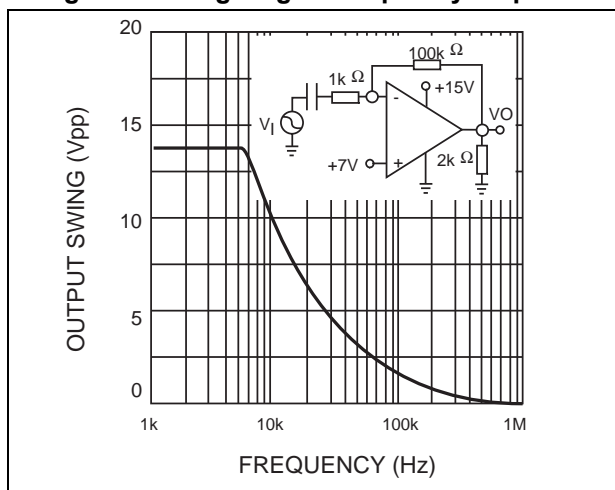

Figure 13. Output characteristics (source)

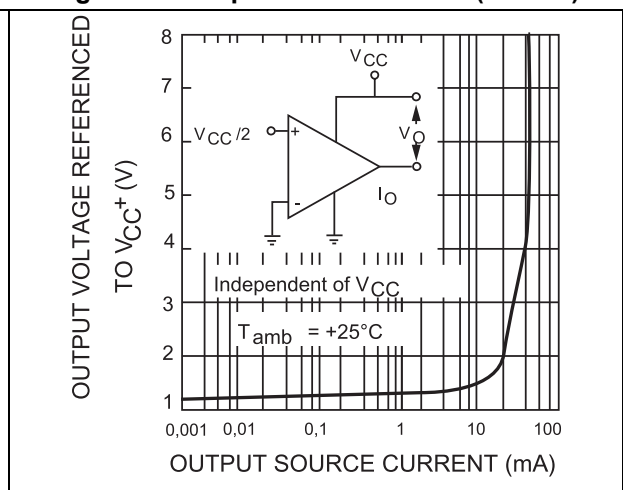

Figure 14. Input current

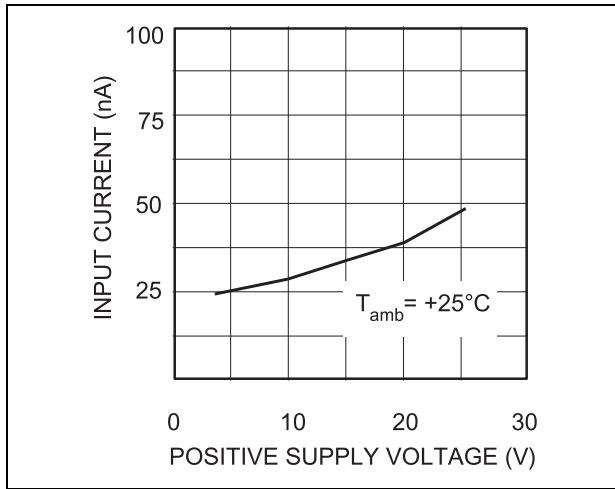

Figure 15. Voltage gain

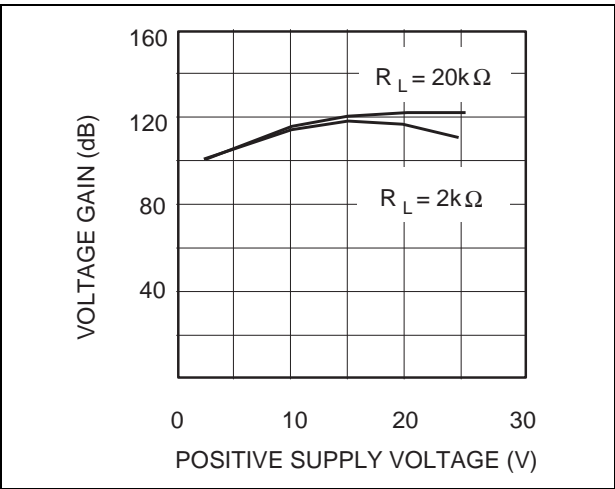

Figure 16. Power supply and common-mode rejection ratio

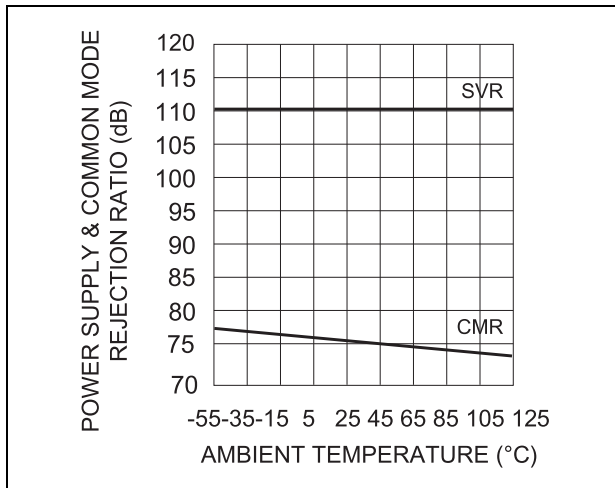
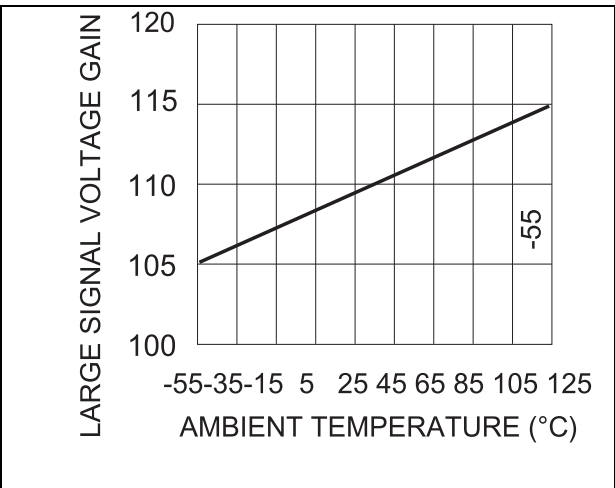

Figure 17. Large signal voltage gain



4 Typical single-supply applications

Figure 18. AC coupled inverting amplifier

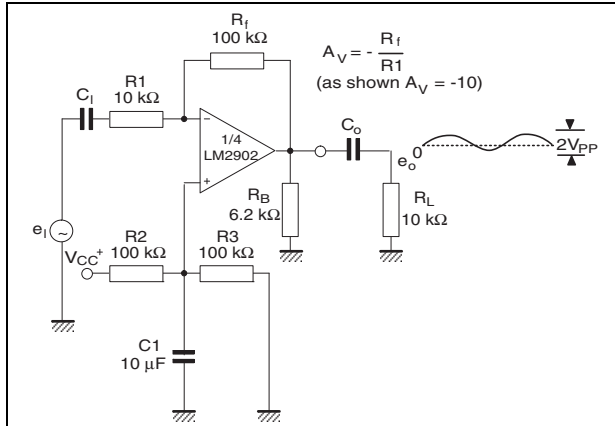

Figure 19. AC coupled non-inverting amplifier

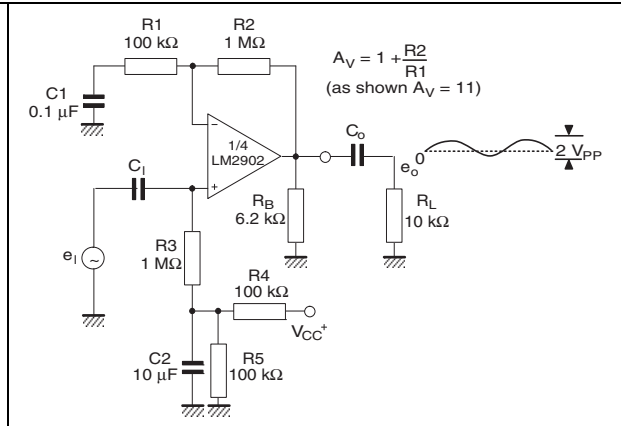

Figure 20. Non-inverting DC gain

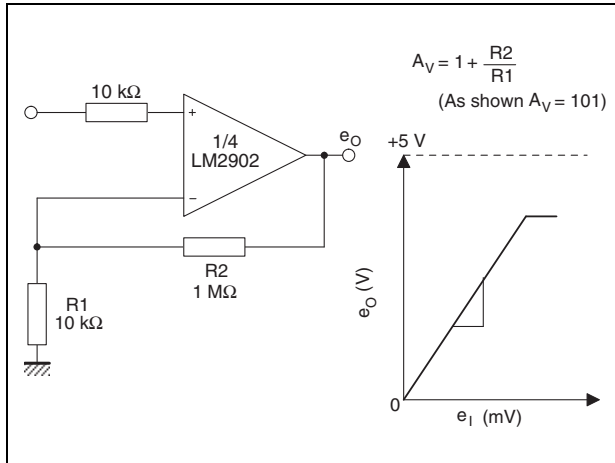

Figure 21. DC summing amplifier

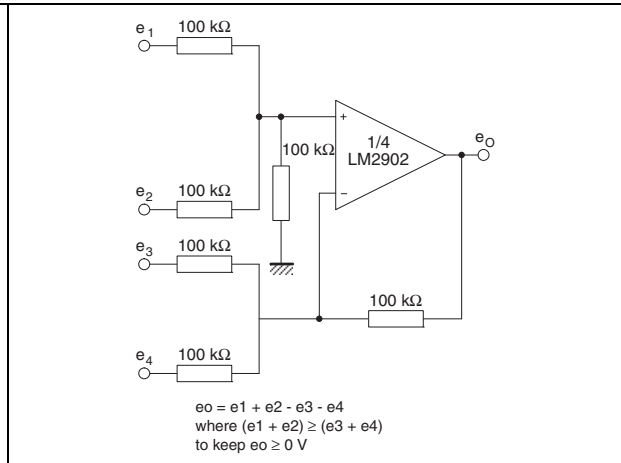

Figure 22. Active bandpass filter

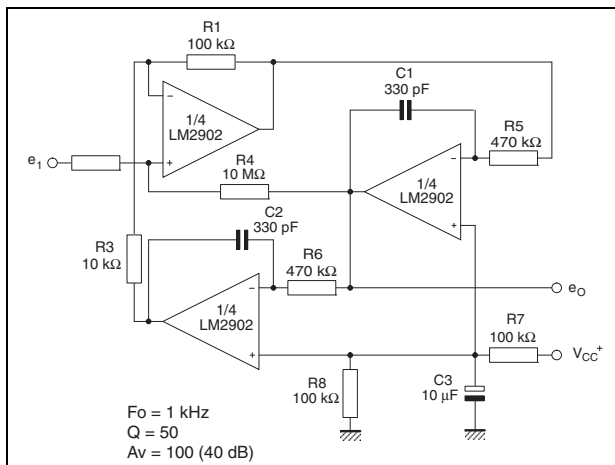

Figure 23. High input Z adjustable gain DC instrumentation amplifier

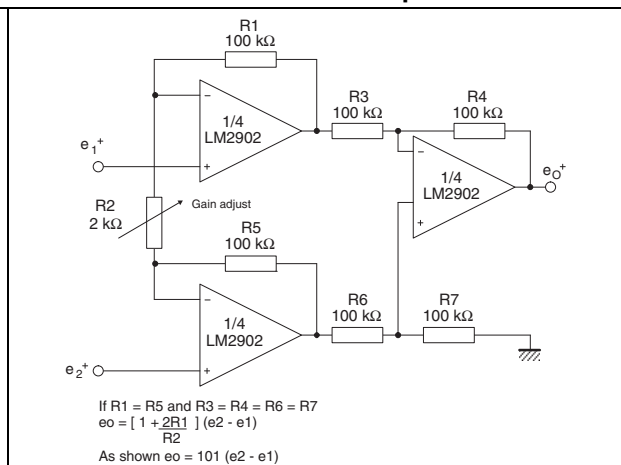

Figure 24. High input Z, DC differential amplifier

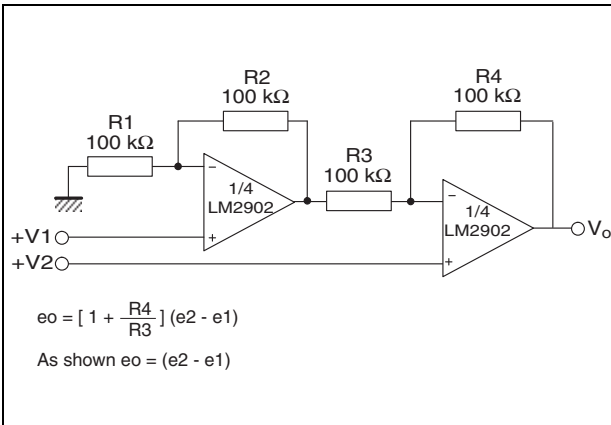

Figure 25. Low drift peak detector

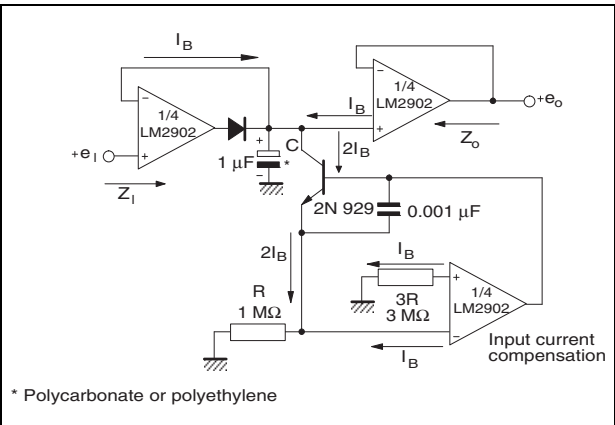
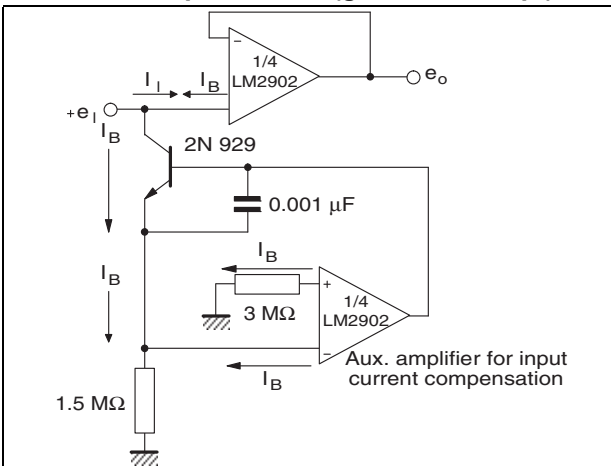

Figure 26. Using symmetrical amplifiers to reduce input current (general concept)



5 Macromodel

An accurate macromodel of the LM2902W is available on STMicroelectronics' web site at www.st.com. This model is a trade-off between accuracy and complexity (that is, time simulation) of the LM2902W operational amplifiers. It emulates the nominal performances of a typical device within the specified operating conditions mentioned in the datasheet. It also helps to validate a design approach and to select the right operational amplifier, *but it does not replace on-board measurements*.

6 Package information

In order to meet environmental requirements, ST offers these devices in different grades of ECOPACK[®] packages, depending on their level of environmental compliance. ECOPACK[®] specifications, grade definitions and product status are available at: www.st.com. ECOPACK[®] is an ST trademark.

6.1 DIP14 package information

Figure 27. DIP14 package mechanical drawing

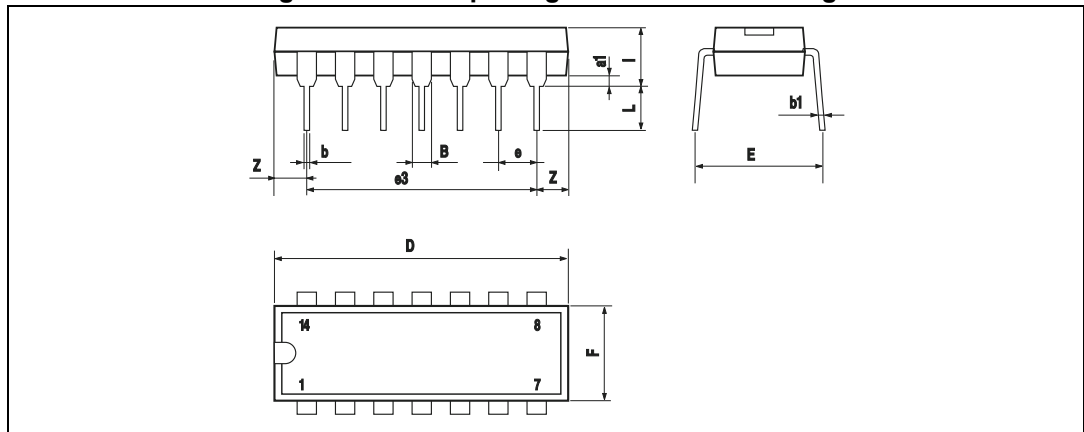

Table 4. DIP14 package mechanical data

Ref.	Dimensions					
	Millimeters			Inches		
	Min.	Typ.	Max.	Min.	Typ.	Max.
a1	0.51			0.020		
B	1.39		1.65	0.055		0.065
b		0.5			0.020	
b1		0.25			0.010	
D			20			0.787
E		8.5			0.335	
e		2.54			0.100	
e3		15.24			0.600	
F			7.1			0.280
I			5.1			0.201
L		3.3			0.130	
Z	1.27		2.54	0.050		0.100

6.2 SO14 package information

Figure 28. SO14 package mechanical drawing

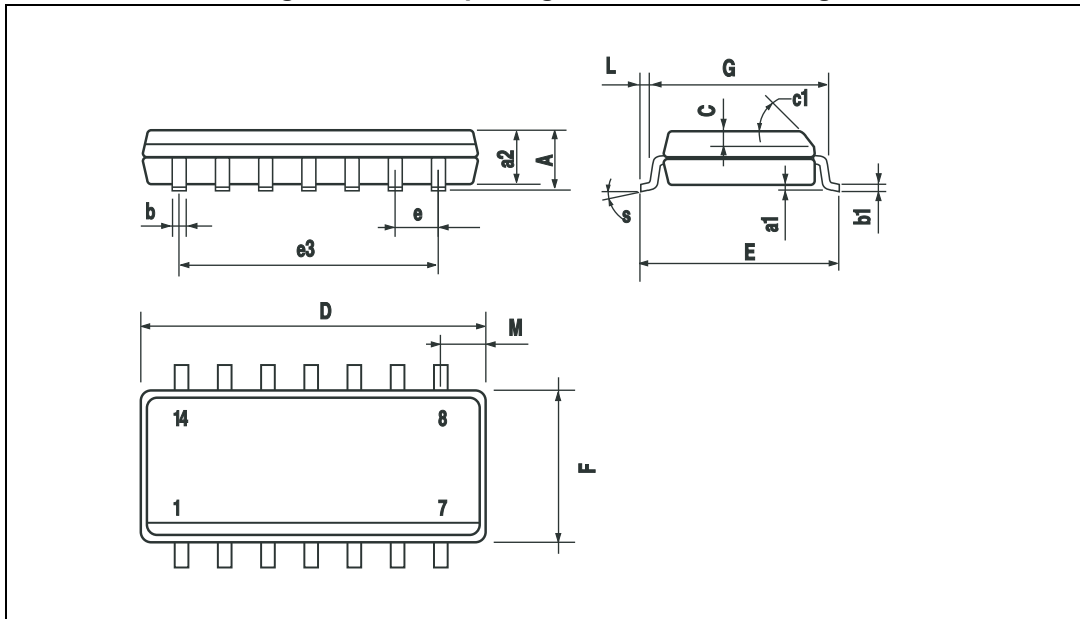

Table 5. SO14 package mechanical data

Ref.	Dimensions					
	Millimeters			Inches		
	Min.	Typ.	Max.	Min.	Typ.	Max.
A			1.75			0.068
a1	0.1		0.2	0.003		0.007
a2			1.65			0.064
b	0.35		0.46	0.013		0.018
b1	0.19		0.25	0.007		0.010
C		0.5			0.019	
c1	45 ° (typ.)					
D	8.55		8.75	0.336		0.344
E	5.8		6.2	0.228		0.244
e		1.27			0.050	
e3		7.62			0.300	
F	3.8		4.0	0.149		0.157
G	4.6		5.3	0.181		0.208
L	0.5		1.27	0.019		0.050
M			0.68			0.026
S	8 ° (max.)					

6.3 TSSOP14 package information

Figure 29. TSSOP14 package mechanical drawing

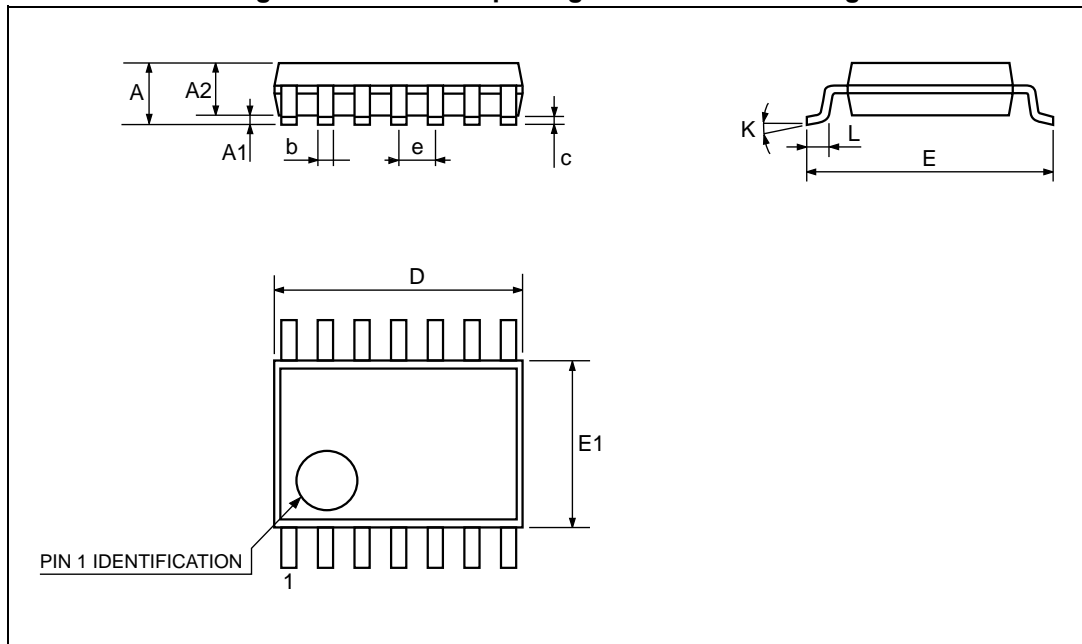

Table 6. TSSOP14 package mechanical data

Ref.	Dimensions					
	Millimeters			Inches		
	Min.	Typ.	Max.	Min.	Typ.	Max.
A			1.2			0.047
A1	0.05		0.15	0.002	0.004	0.006
A2	0.8	1	1.05	0.031	0.039	0.041
b	0.19		0.30	0.007		0.012
c	0.09		0.20	0.004		0.0089
D	4.9	5	5.1	0.193	0.197	0.201
E	6.2	6.4	6.6	0.244	0.252	0.260
E1	4.3	4.4	4.48	0.169	0.173	0.176
e		0.65 BSC			0.0256 BSC	
K	0°		8°	0°		8°
L1	0.45	0.60	0.75	0.018	0.024	0.030

7 Ordering information

Table 7. Order codes

Order code	Temperature range	Package	Packing	Marking
LM2902WYDT ⁽¹⁾	-40 °C to +125 °C	SO14 (Automotive grade level)	Tape and reel	2902WY
LM2902AWYDT ⁽¹⁾		SO14 (Automotive grade level)		2902AWY
LM2902WPT		TSSOP14		2902W
LM2902WYPT ⁽¹⁾		TSSOP14 (Automotive grade level)		2902WY
LM2902AWYPT ⁽¹⁾		TSSOP14 (Automotive grade level)		2902AWY

1. Qualification and characterization according to AEC Q100 and Q003 or equivalent, advanced screening according to AEC Q001 & Q 002 or equivalent.

8 Revision history

Table 8. Document revision history

Date	Revision	Changes
01-Sep-2003	1	Initial release.
01-Nov-2005	2	Table data reformatted for easier use in Electrical characteristics on page 5 . Minor grammatical and formatting changes throughout.
01-Jan-2006	3	LM2902WYPT PPAP reference inserted in order codes table, see Section 7 on page 16 .
01-May-2006	4	Minimum value of slew rate at 25°C and on full temperature range added in Table 3 on page 5 .
20-Jul-2007	5	Corrected document title to “quad operational amplifier”. Corrected ESD value for HBM to 800V. Corrected thermal resistance junction to ambient values in Table 1: Absolute maximum ratings . Updated electrical characteristics curves. Added Section 5: Macromodel . Added automotive grade order codes in Section 7 on page 16 .
15-Jan-2008	6	Corrected footnotes for automotive grade order codes.
17-Oct-2008	7	Added enhanced V _{io} version: LM2902AW. Corrected V _{OH} min parameter at V _{cc} =5V in Table 3 on page 5 .
16-Feb-2012	8	Modified Chapter 5: Macromodel . Deleted LM2902WYD and LM2902AWYD order codes from Table 7 and modified status of LM2902WYPT and LM2902AWYPT order codes.
22-Jul-2013	9	Table 3 : DV _{io} replaced with $\Delta V_{io}/\Delta T$ Table 7 : Removed the order codes LM2902WN and LM2902WD; replaced the order codes LM2902WDT and LM2902AWDT with LM2902WYDT and LM2902AWYDT respectively.

Please Read Carefully:

Information in this document is provided solely in connection with ST products. STMicroelectronics NV and its subsidiaries ("ST") reserve the right to make changes, corrections, modifications or improvements, to this document, and the products and services described herein at any time, without notice.

All ST products are sold pursuant to ST's terms and conditions of sale.

Purchasers are solely responsible for the choice, selection and use of the ST products and services described herein, and ST assumes no liability whatsoever relating to the choice, selection or use of the ST products and services described herein.

No license, express or implied, by estoppel or otherwise, to any intellectual property rights is granted under this document. If any part of this document refers to any third party products or services it shall not be deemed a license grant by ST for the use of such third party products or services, or any intellectual property contained therein or considered as a warranty covering the use in any manner whatsoever of such third party products or services or any intellectual property contained therein.

UNLESS OTHERWISE SET FORTH IN ST'S TERMS AND CONDITIONS OF SALE ST DISCLAIMS ANY EXPRESS OR IMPLIED WARRANTY WITH RESPECT TO THE USE AND/OR SALE OF ST PRODUCTS INCLUDING WITHOUT LIMITATION IMPLIED WARRANTIES OF MERCHANTABILITY, FITNESS FOR A PARTICULAR PURPOSE (AND THEIR EQUIVALENTS UNDER THE LAWS OF ANY JURISDICTION), OR INFRINGEMENT OF ANY PATENT, COPYRIGHT OR OTHER INTELLECTUAL PROPERTY RIGHT.

ST PRODUCTS ARE NOT AUTHORIZED FOR USE IN WEAPONS. NOR ARE ST PRODUCTS DESIGNED OR AUTHORIZED FOR USE IN: (A) SAFETY CRITICAL APPLICATIONS SUCH AS LIFE SUPPORTING, ACTIVE IMPLANTED DEVICES OR SYSTEMS WITH PRODUCT FUNCTIONAL SAFETY REQUIREMENTS; (B) AERONAUTIC APPLICATIONS; (C) AUTOMOTIVE APPLICATIONS OR ENVIRONMENTS, AND/OR (D) AEROSPACE APPLICATIONS OR ENVIRONMENTS. WHERE ST PRODUCTS ARE NOT DESIGNED FOR SUCH USE, THE PURCHASER SHALL USE PRODUCTS AT PURCHASER'S SOLE RISK, EVEN IF ST HAS BEEN INFORMED IN WRITING OF SUCH USAGE, UNLESS A PRODUCT IS EXPRESSLY DESIGNATED BY ST AS BEING INTENDED FOR "AUTOMOTIVE, AUTOMOTIVE SAFETY OR MEDICAL" INDUSTRY DOMAINS ACCORDING TO ST PRODUCT DESIGN SPECIFICATIONS. PRODUCTS FORMALLY ESCC, QML OR JAN QUALIFIED ARE DEEMED SUITABLE FOR USE IN AEROSPACE BY THE CORRESPONDING GOVERNMENTAL AGENCY.

Resale of ST products with provisions different from the statements and/or technical features set forth in this document shall immediately void any warranty granted by ST for the ST product or service described herein and shall not create or extend in any manner whatsoever, any liability of ST.

ST and the ST logo are trademarks or registered trademarks of ST in various countries.

Information in this document supersedes and replaces all information previously supplied.

The ST logo is a registered trademark of STMicroelectronics. All other names are the property of their respective owners.

© 2013 STMicroelectronics - All rights reserved

STMicroelectronics group of companies

Australia - Belgium - Brazil - Canada - China - Czech Republic - Finland - France - Germany - Hong Kong - India - Israel - Italy - Japan - Malaysia - Malta - Morocco - Philippines - Singapore - Spain - Sweden - Switzerland - United Kingdom - United States of America

www.st.com