



Quick Disconnect

880-030R Rear Panel Mount, Right Angle PCB Receptacle



Series 880 Quick-Disconnect (QDC) rear panel mount, PCB receptacles are sealed with epoxy and meet IP67 requirements in mated condition. For open face sealing in an unmated condition request modification code -518. Three contact sizes are available with current ratings of 5A, 3A and 1A. Aluminum or stainless steel housings and thermoplastic insulators. High performance crimp contacts are factory terminated to solid copper wire. Ultraminiature SuperFly® connectors are ideal for soldier systems and other applications where reduced size and weight are critical.

B

Shell Size and Insert Arrangements			
Insert Arrangements	No. of Contacts		
	#23 5A.	Micro 3A.	Nano 1A.
B7N	—	—	7
C10N	—	—	10
C2M2N	—	2	2
D3M	—	3	—
D2W2N	2	—	2
E3W	3	—	—
E4M	—	4	—
E19N	—	—	19
E4M4N	—	4	4
F4W	4	—	—
F7M	—	7	—
F22N	—	—	22
F4M8N	—	4	8
F4W4N	4	—	4
G7W	7	—	—
G10M	—	10	—
G31N	—	—	31
G6M10N	—	6	10
G6M12N	—	6	12
H10W	10	—	—
H37N	—	—	37
H6W14N	6	—	14
J44N	—	—	44
J7W19N	7	—	19
K19M	—	19	—
K13M19N	—	13	19
L22M	—	22	—

First letter of insert arrangement represents connector shell size, as in this example: **K13M19N**

NOTES

- See Section A for insert arrangement layouts
- See Section A for additional finish options

How To Order						
Sample Part Number	880-030R	A	-B7N	-M	S	-.125
Series	880-030R					
Insert Style	A = Unshrouded contacts B = Shrouded contacts recessed within insulator					
Shell Size/Insert Arr.¹	See Shell Size and Insert Arrangement Table					
Material/Finish²	M = Aluminum/electroless nickel RoHS compliant ZR = Aluminum/zinc-nickel, non-reflective with RoHS compliant black chromate MT = Aluminum/nickel-PTFE RoHS compliant ZMT = Stainless steel/nickel-PTFE RoHS compliant					
PC Tail Finish	S = Solder-dipped in 63/37 tin-lead G = Gold Plated					
PC Tail Length	.080, .125, .175 ; Length ('L') in inches					

MOD-686 POLARIZING OPTIONS

Standard Superfly connectors have a single master key. Versions with three keys are also available if alternate key positions are required. Add suffix code 686 to the part number per the following example: 880-030RA-B7N-MS-.125-**686A**

Plug Alternate Key Positions		
Suffix Code	A°	B°
686A	150°	210°
686B	75°	210°
686C	95°	230°
686D	140°	275°
686E	75°	275°
686F	95°	210°

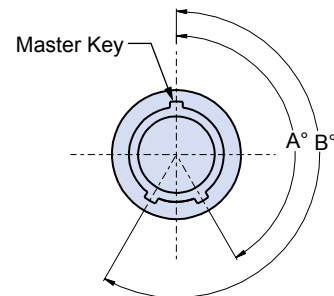

MOD-518 OPEN FACE SEALING

For IP67 performance in open face (unmated) condition, use suffix -518. Example: 880-030RA-B7N-MS-.125-**518**



Quick Disconnect

880-030R Rear Panel Mount, Right Angle PCB Receptacle



ABOUT SHROUDED AND UNSHROUDED SUPERFLY® CONFIGURATIONS

Shrouded contacts are recessed within the insert. Unshrouded contacts extend from the insert face. Shrouded inserts contain 1 amp and 3 amp Twistpin contacts along with 5 amp socket contacts. Unshrouded inserts contain 1 amp and 3 amp sockets and 5 amp pin.

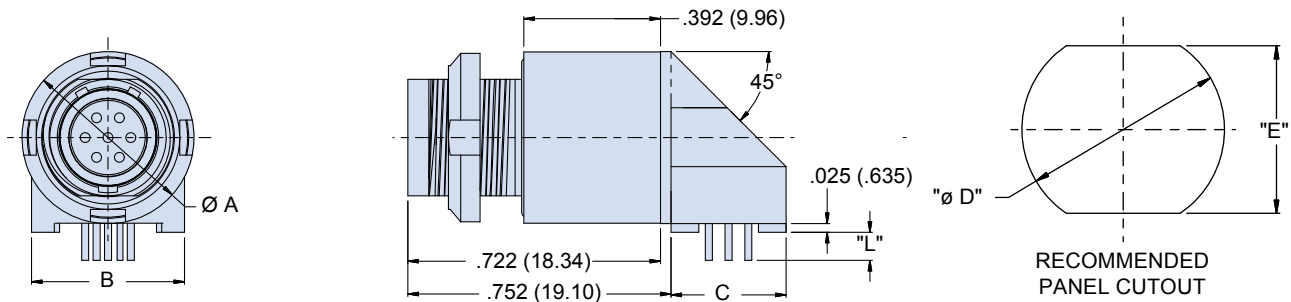
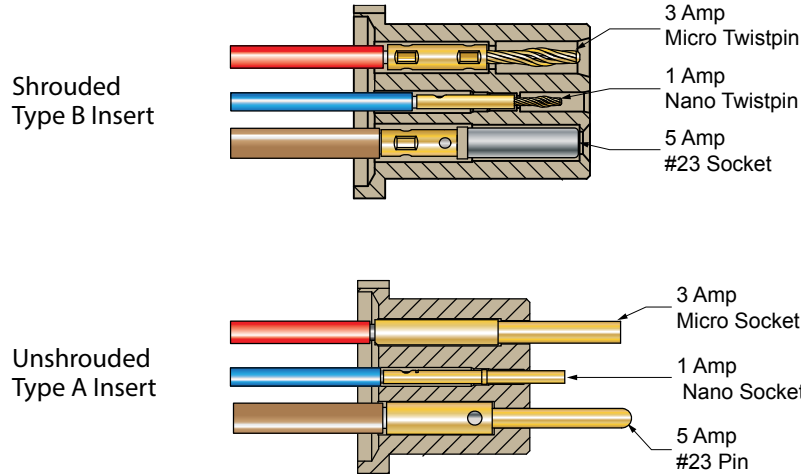

Dimensions										
Shell Size	A		B		C Max		D Mount Ø		E Flats	
	in	mm	in	mm	in	mm	in	mm	in	mm
B	0.392	9.96	0.338	8.59	0.260	6.60	0.283	7.19	0.241	6.12
C	0.412	10.46	0.358	9.09	0.280	7.11	0.305	7.75	0.261	6.63
D	0.431	10.95	0.377	9.58	0.300	7.62	0.324	8.23	0.281	7.14
E	0.451	11.46	0.397	10.08	0.320	8.13	0.344	8.74	0.300	7.62
F	0.471	11.96	0.417	10.59	0.340	8.64	0.364	9.25	0.320	8.13
G	0.490	12.45	0.436	11.07	0.380	9.65	0.383	9.73	0.340	8.64
H	0.530	13.46	0.476	12.09	0.400	10.16	0.419	10.64	0.379	9.63
J	0.569	14.45	0.515	13.08	0.440	11.18	0.459	11.66	0.418	10.62
K	0.589	14.96	0.534	13.56	0.460	11.68	0.478	12.14	0.438	11.13
L	0.628	15.95	0.574	14.58	0.500	12.70	0.518	13.16	0.478	12.14