

Rev	AWO #	Description	Date	Appr
-		RELEASED	8/23/10	

APPROVED: _____ TITLE: _____
 DATE: _____

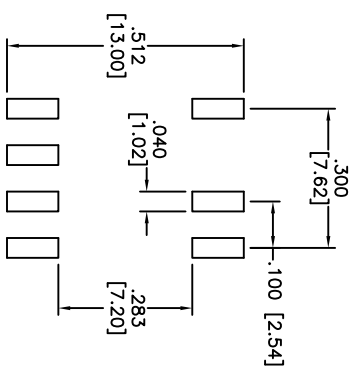
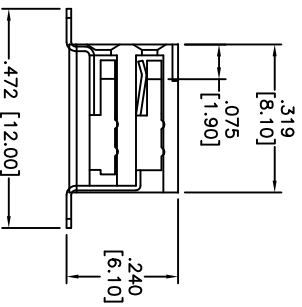
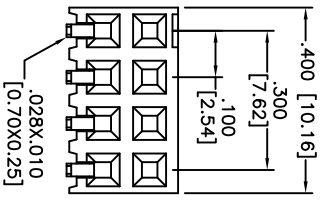
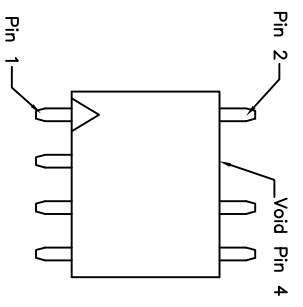

RECOMMENDED P.C.B LAYOUT

SPECIFICATIONS:

Material:
 Insulator: Nylon 6T, rated UL 94V-0

Insulator color: Black

Contacts: Phosphor Bronze

Plating:
 10u" Gold over Nickel underplate on contact area,
 Tin over Copper underplate on SMT tails

Electrical:
 Operating voltage: 250 VAC max
 Current rating: 3 Amps max
 Contact resistance: 20 mOHMS MAX
 Insulation resistance: 1000 Mohms min
 Dielectric withstanding voltage: 600 VAC for 1 minute

Temperature Rating:
 Operating temperature: -40°C to +105°C
 Environmental:
 Lead free, RoHS compliant.

Recommended soldering temp: 260°C for 5 sec.

PACKAGED ON TAPE & REEL

UNLESS OTHERWISE SPECIFIED ALL DIMENSIONS ARE INCHES [MM]	
TOLERANCES: EXCEPT AS NOTED	
INCHES	HOLDS
.X ± .10	Ø.X ± .10
.XX ± .020	Ø.XX ± .015
.XXX ± .015	Ø.XXX ± .010
APPROVALS	
DATE	

DRAWN	DY	8/23/10
CHECKED		
APPROVED		

ADAM TECH

909 Rahway Avenue, Union, NJ 07083
 Phone: 908-687-5000 Fax: 908-687-5710

RECEPTACLE STRIP, .100 DUAL ROW
 SIDE ENTRY, 10u" SEL GOLD PLATED

SIZE	PART NO.	REV.
X	RS2BR-08-SG-SMT-10-X04-T/R	-
REF:	S00032T	
SCALE:	NTS	
SHEET	1 OF 1	

6 5 4 3 2 1

A B C D

A B C D