



**QUICKSWITCH® PRODUCTS
HIGH-PERFORMANCE CMOS
SIX CHANNEL SP4T MUX/DEMUX**

IDTQS4A215

FEATURES:

- Low ON resistance: $r_{DS(ON)} = 5\Omega$
- Fast transition time: $t_{TRAN} = 6ns$
- Wide bandwidth: 700MHz (-3dB point)
- Crosstalk: -110dB at 50KHz, -68dB at 5MHz, -66dB at 30MHz
- Off-isolation: -90dB at 50KHz, -60dB at 5MHz, -50dB at 30MHz
- Single 5V supply
- Can be used as multiplexer or demultiplexer
- TTL-compatible control inputs
- Ultra-low quiescent current: 9 μ A
- Available in QSOP package

APPLICATIONS:

- High-speed video signal switching/routing
- HDTV-quality video signal multiplexing
- Audio signal switching/routing
- Data acquisition
- ATE systems
- Telecomm routing
- Switch between multiple video sources
- Token Ring transceivers
- High-speed networking

DESCRIPTION:

The QS4A215 is a high-performance CMOS six-channel multiplexer/demultiplexer with individual enables. The low ON-resistance of the QS4A215 allows inputs to be connected to outputs with low insertion loss and high bandwidth. TTL-compatible control circuitry with "Break-Before-Make" feature prevents contention.

The QS4A215 with 700MHz bandwidth makes it ideal for high-performance video signal switching, audio signal switching, and telecom routing applications. High performance and low power dissipation makes this device ideal for battery operated and remote instrumentation applications.

The QS4A215 is offered in the QVSOP package which has several advantages over conventional packages such as PDIP and SOIC, including:

- Reduced signal delays due to denser component packaging on circuit boards
- Reduced system noise due to less pin inductance, resulting in lower ground bounce

The QS4A215 is characterized for operation at -40°C to +85°C.

FUNCTIONAL BLOCK DIAGRAM

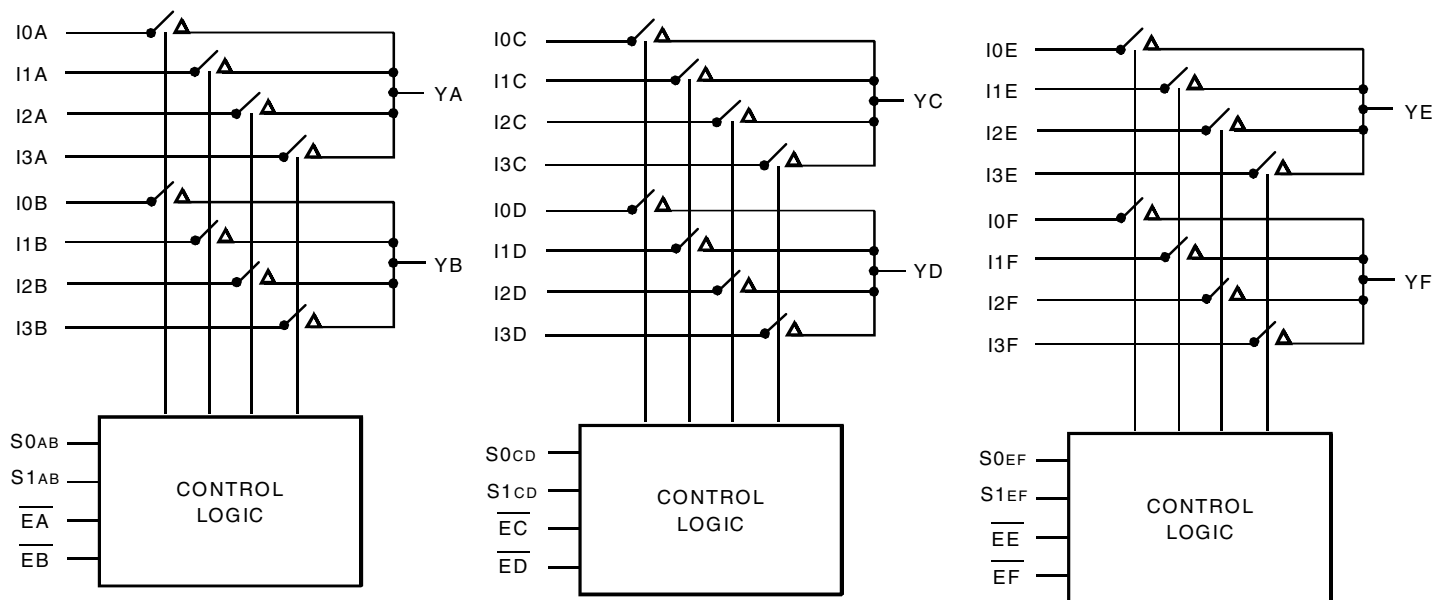

The IDT logo is a registered trademark of Integrated Device Technology, Inc.

PIN CONFIGURATION

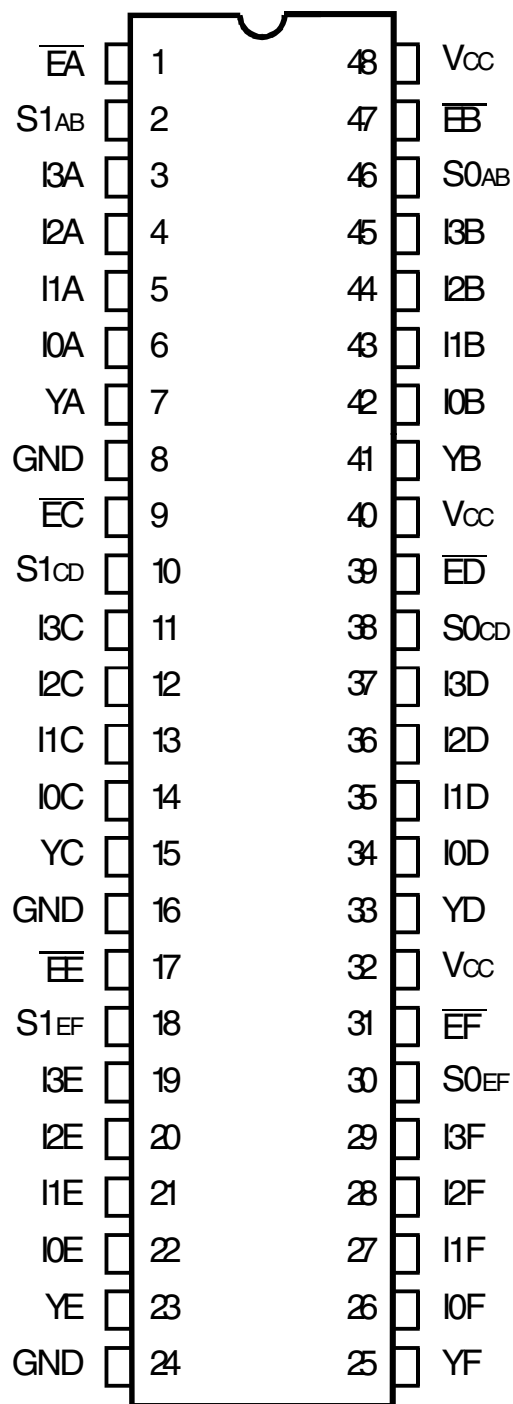

QVSOPTOP VIEW

ABSOLUTE MAXIMUM RATINGS⁽¹⁾

| Symbol | Description | Max | Unit |
|----------------------|--------------------------------------|-------------|------|
| VTERM ⁽²⁾ | Supply Voltage to Ground | -0.5 to +7 | V |
| VTERM ⁽³⁾ | DC Switch Voltage Vs | -0.5 to +7 | V |
| — | Analog Input Voltage | -0.5 to +7 | V |
| VTERM ⁽³⁾ | DC Input Voltage VIN | -0.5 to +7 | V |
| VAC | AC Input Voltage (pulse width ≤20ns) | -3 | V |
| IOUT | DC Output Current | 120 | mA |
| P _{MAX} | Maximum Power Dissipation | 0.7 | W |
| TSTG | Storage Temperature | -65 to +150 | °C |

NOTES:

1. Stresses greater than those listed under ABSOLUTE MAXIMUM RATINGS may cause permanent damage to the device. This is a stress rating only and functional operation of the device at these or any other conditions above those indicated in the operational sections of this specification is not implied. Exposure to absolute maximum rating conditions for extended periods may affect reliability.
2. V_{CC} terminals.
3. All terminals except V_{CC}.

PIN DESCRIPTION

| Pin Names | I/O | Description |
|-------------------------------------|-----|-------------------|
| I _{xx} | I/O | Demux Ports A-F |
| S _{0xx} , S _{1xx} | I | Select Inputs |
| E _x | I | Enable Inputs A-F |
| Y _x | I/O | Mux Ports A-F |

FUNCTION TABLE⁽¹⁾

| Enable | | Select | | Mux/Demux Ports | | Function |
|----------------|----------------|----------------|----------------|-----------------|-----------------|---|
| E _A | E _B | S ₁ | S ₀ | Y _A | Y _B | |
| H | X | X | X | Z | X | Disable A |
| X | H | X | X | X | Z | Disable B |
| L | L | L | L | I _{0A} | I _{0B} | S _{1AB} , S _{0AB} = 0 |
| L | L | L | H | I _{1A} | I _{1B} | S _{1AB} , S _{0AB} = 1 |
| L | L | H | L | I _{2A} | I _{2B} | S _{1AB} , S _{0AB} = 2 |
| L | L | H | H | I _{3A} | I _{3B} | S _{1AB} , S _{0AB} = 3 |

NOTE:

1. H = HIGH Voltage Level
L = LOW Voltage Level
X = Don't Care
Z = High-Impedance
2. This function table represents the function for block "AB". The "CD" block nomenclature substitutes "A" for "C" and "B" for "D". The "EF" block nomenclature substitutes "A" for "E" and "B" for "F".

DC ELECTRICAL CHARACTERISTICS OVER OPERATING RANGE

Following Conditions Apply Unless Otherwise Specified:

Industrial: $T_A = -40^{\circ}\text{C}$ to $+85^{\circ}\text{C}$, $V_{CC} = 5\text{V} \pm 5\%$

| Symbol | Parameter | Test Conditions | Min. | Typ. ⁽¹⁾ | Max. | Unit |
|--------------------------------|--|---|------|---------------------|--------------|----------|
| Analog Switch | | | | | | |
| V_{IN} | Analog Signal Range ⁽²⁾ | | -0.5 | 1 | $V_{CC} - 1$ | V |
| $r_{DS(ON)}$ | Drain-source ON resistance ^(2,3) | $V_{CC} = \text{Min.}, V_{IN} = 0\text{V}, I_{ON} = 30\text{mA}$ | — | 5 | 7 | Ω |
| | | $V_{CC} = \text{Min.}, V_{IN} = 2.4\text{V}, I_{ON} = 15\text{mA}$ | — | 13 | 17 | |
| $I_{C(OFF)}$ | Channel Off Leakage Current | $I_N = V_{CC}$ or 0V ; $Y_N = 0\text{V}$ or V_{CC} ; $\overline{E\overline{X}} = V_{CC}$ | — | 10 | — | nA |
| $I_{C(ON)}$ | Channel On Leakage Current | $I_N = Y_N = 0\text{V}$ (each channel is turned on sequentially) | — | 10 | — | nA |
| Digital Control | | | | | | |
| V_{IH} | Input HIGH Voltage | Guaranteed Logic HIGH for Control Pins | 2 | — | — | V |
| V_{IL} | Input LOW Voltage | Guaranteed Logic LOW for Control Pins | — | — | 0.8 | V |
| Dynamic Characteristics | | | | | | |
| t_{TRANS} | Switching Time of Mux Sx to Yx | $R_L = 1\text{K}\Omega, C_L = 100\text{pF}$ (See Transition Time) | 0.5 | — | 6.6 | ns |
| $t_{ON(\overline{EN})}$ | Enable Turn-On Time $\overline{E\overline{X}}$ to Yx | $R_L = 1\text{K}\Omega, C_L = 100\text{pF}$ (See Switching Time) | 0.5 | — | 6 | ns |
| $t_{OFF(\overline{EN})}$ | Enable Turn-Off Time $\overline{E\overline{X}}$ to Yx | $R_L = 1\text{K}\Omega, C_L = 100\text{pF}$ (See Switching Time) | 0.5 | — | 6 | ns |
| t_{PD} | Group Delay ^(2,4) | $R_L = 1\text{K}\Omega, C_L = 100\text{pF}$ | — | — | 250 | ps |
| f_{3dB} | -3dB Bandwidth | $V_{IN} = 1\text{Vp-p}, R_L = 75\Omega$ | — | 700 | — | MHz |
| | Off-isolation | $V_{IN} = 1\text{Vp-p}, R_L = 75\Omega, f = 5\text{MHz}$ | — | -60 | — | dB |
| X TALK | Crosstalk | $V_{IN} = 1\text{Vp-p}, R_L = 75\Omega, f = 5\text{MHz}$ | — | -68 | — | dB |
| $C_{MUX(OFF)}$ | Mux Off Capacitance | $\overline{E\overline{X}} = V_{CC}, V_{IN} = V_{OUT} = 0\text{V}$ | — | 6 | — | pF |
| $C_{DEMUX(OFF)}$ | Demux Off Capacitance | $\overline{E\overline{X}} = V_{CC}, V_{IN} = V_{OUT} = 0\text{V}$ | — | 14 | — | pF |
| $C_{MUX(ON)}$ | Mux On Capacitance | $\overline{E\overline{X}} = 0\text{V}, V_{IN} = V_{OUT} = 0\text{V}$ | — | 20 | — | pF |
| $C_{DEMUX(ON)}$ | Demux On Capacitance | $\overline{E\overline{X}} = 0\text{V}, V_{IN} = V_{OUT} = 0\text{V}$ | — | 20 | — | pF |
| QCI | Charge Injection | $C_L = 1000\text{pF}$ | — | 1.5 | — | pC |

NOTES:

- Typical values are at $V_{CC} = 5.0\text{V}$, $T_A = 25^{\circ}\text{C}$.
- Max value is guaranteed but not production tested.
- Measured by voltage drop between A and C pins or B and D pins at indicated current through the switch. ON resistance is determined by the lower of the voltages on the two (I, Y) pins.
- The bus switch contributes no group delay other than the RC delay of the ON resistance of the switch and load capacitance. Group delay of the bus switch, when used in a system, is determined by the driving circuit on the driving side of the switch and its interaction with the load on the driven side.

POWER SUPPLY CHARACTERISTICS

| Symbol | Parameter | Test Conditions | Max. | Unit |
|-----------|-----------------|--|------|---------------|
| I_{CCQ} | Quiescent Power | $V_{CC} = \text{Max.}, V_{IN} = \text{GND}$ or $V_{CC}, f = 0$ | 9 | μA |

TYPICAL CHARACTERISTICS

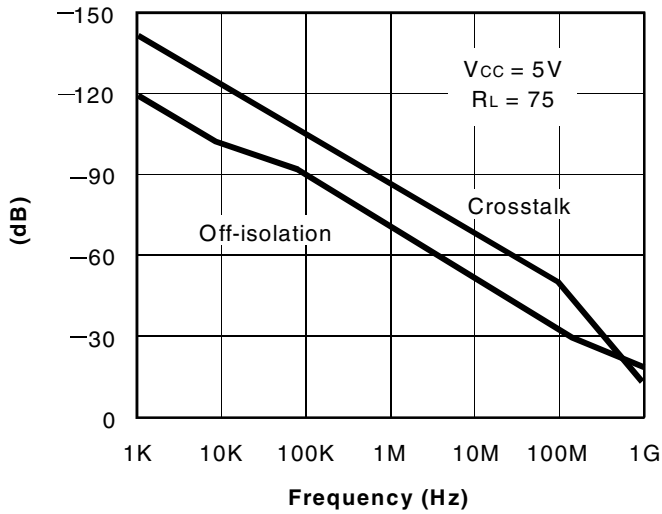

Off-isolation and Crosstalk vs. Frequency

NOTES:
1. Crosstalk = $20 \log |V_o/V_s|$
2. Off-isolation = $20 \log |V_o/V_s|$

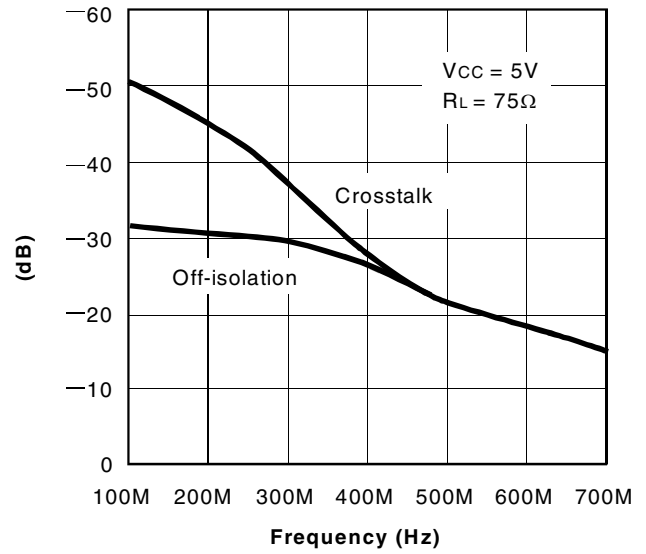

Off-isolation and Crosstalk vs. Frequency

NOTES:
1. Crosstalk = $20 \log |V_o/V_s|$
2. Off-isolation = $20 \log |V_o/V_s|$

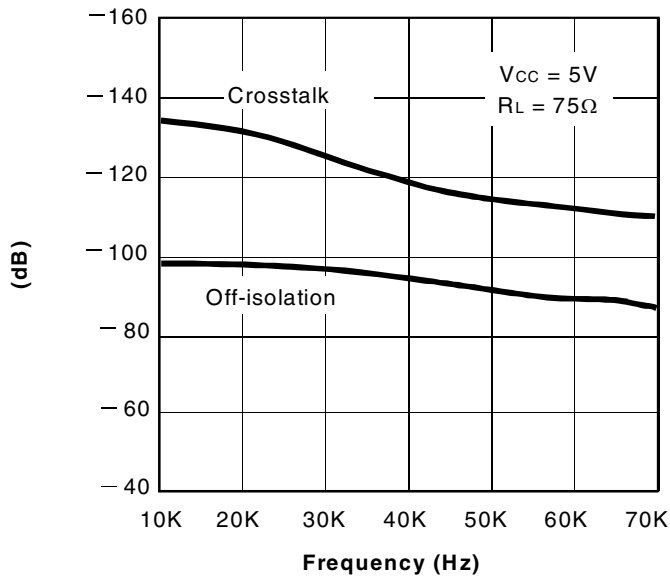

Off-isolation and Crosstalk vs. Frequency

NOTES:
1. Crosstalk = $20 \log |V_o/V_s|$
2. Off-isolation = $20 \log |V_o/V_s|$

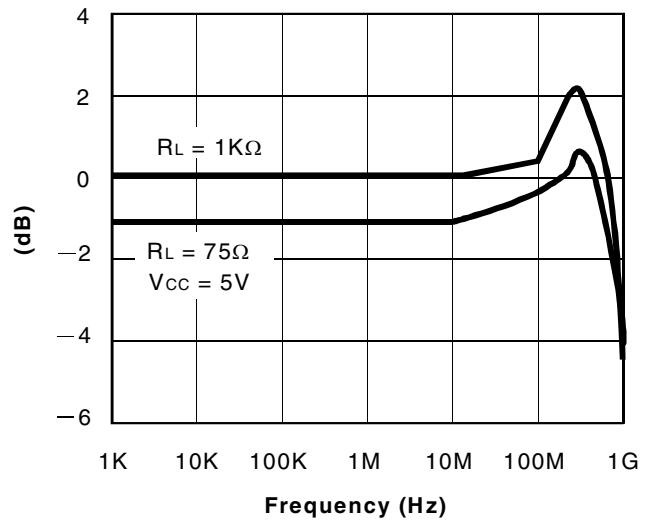

Insertion Loss vs. Frequency

NOTE:
1. Insertion Loss = $20 \log |V_o/V_s|$

TYPICAL CHARACTERISTICS (CONTINUED)

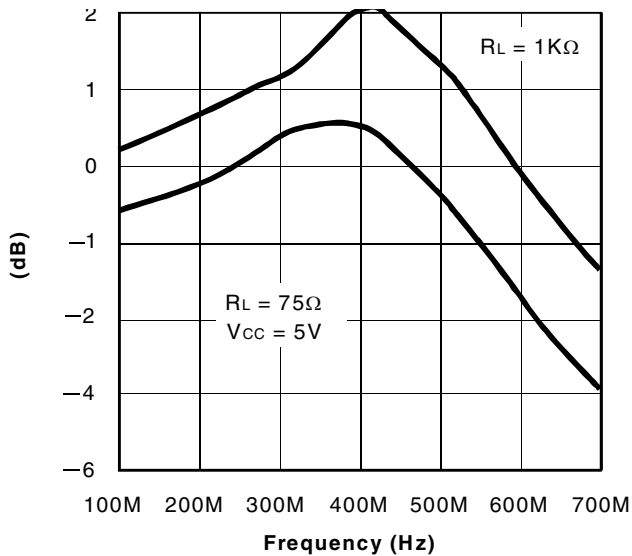

Insertion Loss vs. Frequency

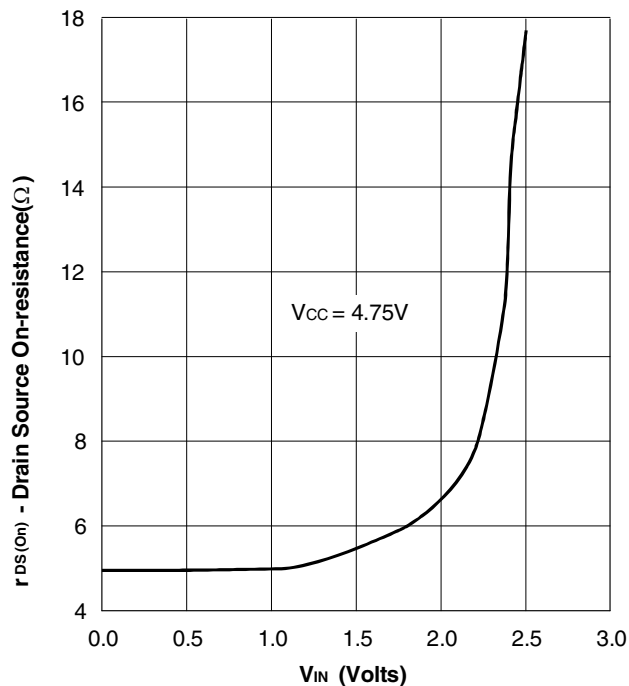

RON LINK

On-Resistance vs. VIN

NOTE:
1. Insertion Loss = 20 log |Vo/Vs|

TEST CIRCUITS

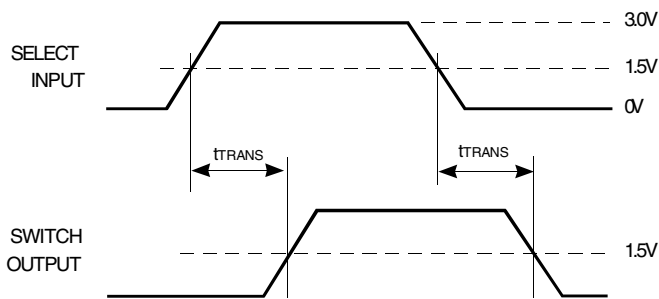
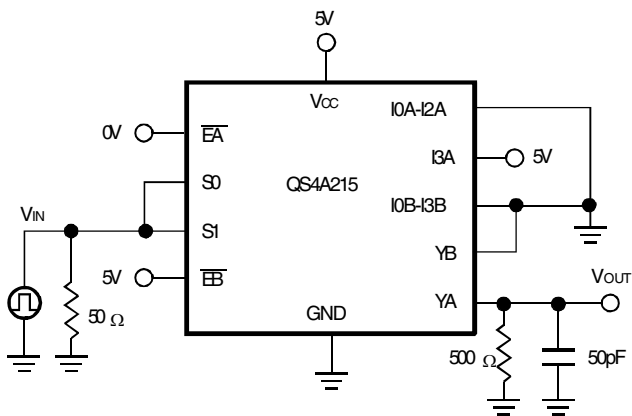

Transition Time

TEST CIRCUITS (CONTINUED)

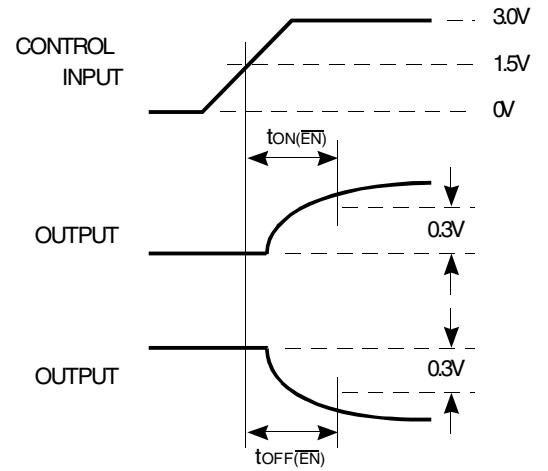
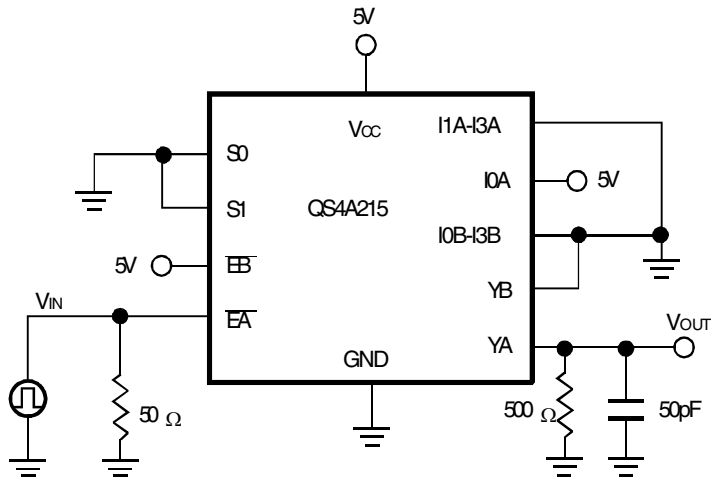

Enable Switching Time

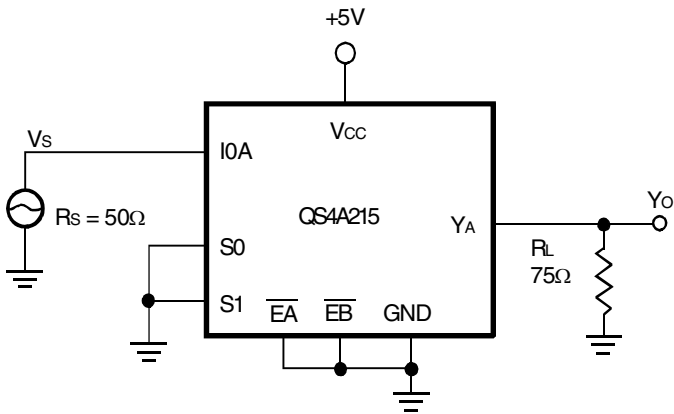

Insertion Loss

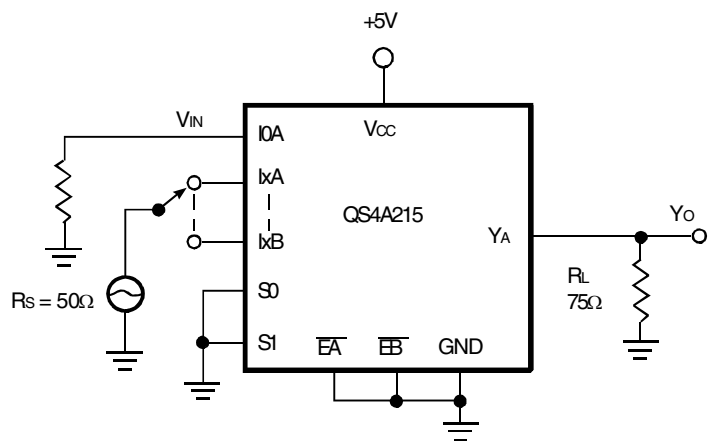

Crosstalk

NOTE:
1. Insertion Loss = $20 \log |V_o/V_s|$

NOTE:
1. Crosstalk = $20 \log |V_o/V_s|$

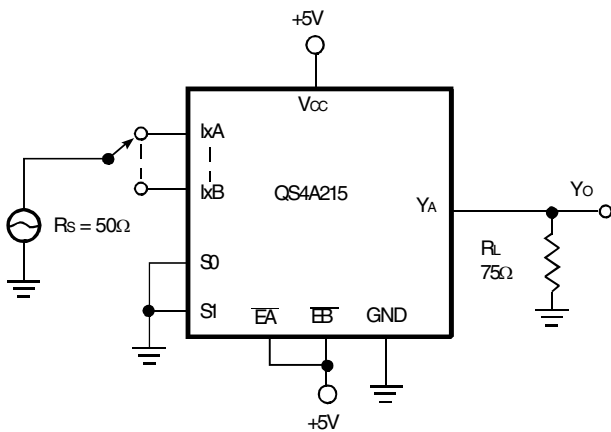

Off-Isolation

NOTE:
1. Off-isolation = $20 \log |V_o/V_s|$

ORDERING INFORMATION

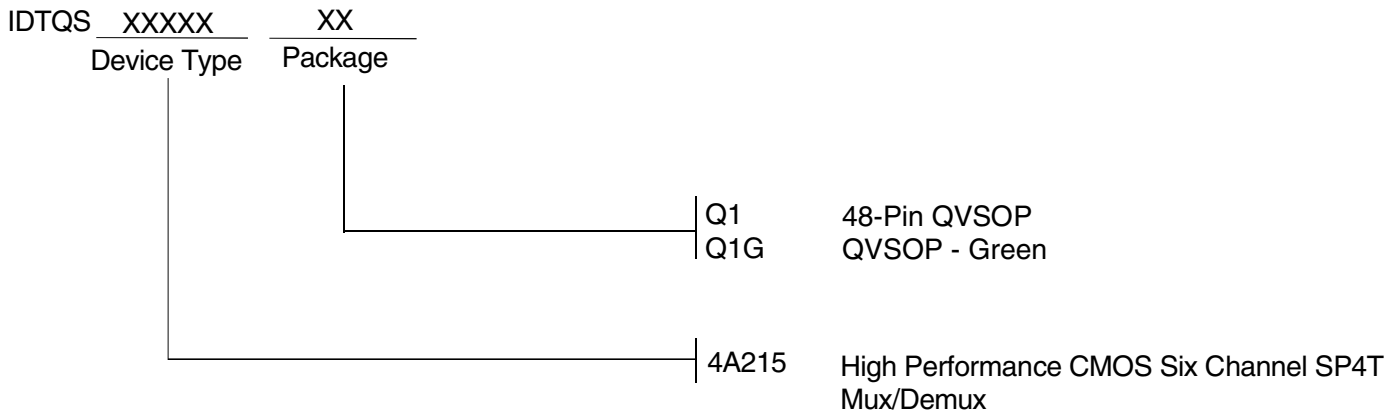

CORPORATE HEADQUARTERS
2975 Stender Way
Santa Clara, CA 95054

for SALES:
800-345-7015 or 408-727-6116
fax: 408-492-8674
www.idt.com

for Tech Support:
logichelp@idt.com
(408) 654-6459