

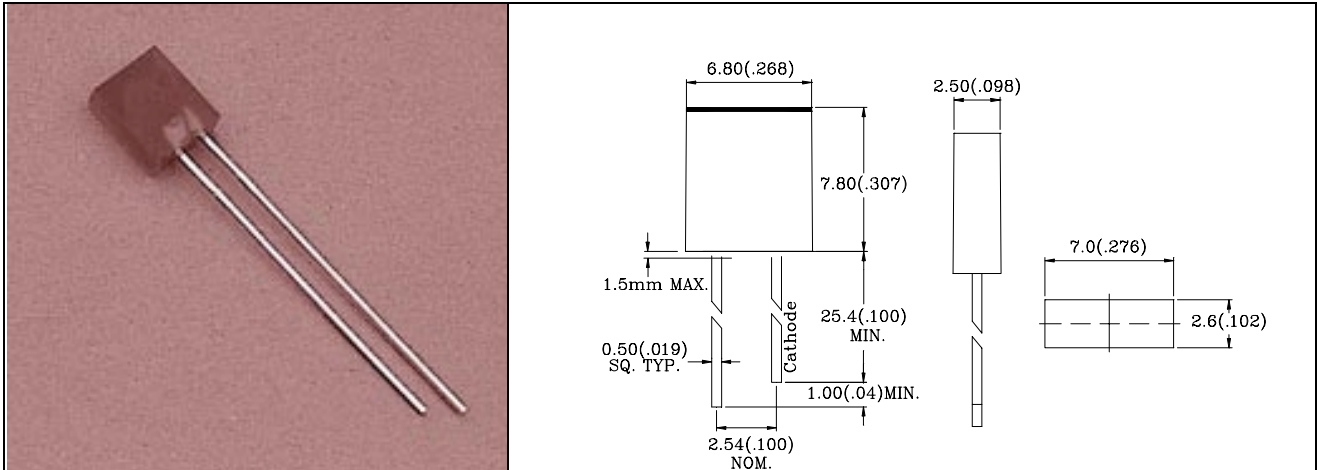

L-423XX 2.5x7.0x7.8mm RECTANGULAR LED LAMP



Part No.	Chip		Lens Color	Wave Length λ p(nm)	Electro-Optical Characteristics			View Angle (deg)
	Raw Material	Emitted Color			Vf(V)20mA		Iv(mcd)10mA	
					Typ.	Max.	Typ.	
L-423HD	GaP	Red	Red Diffused	700	2.1	2.8	5.0	130
L-423GD	GaP	Green	Green Diffused	565	2.1	2.8	10.0	130
L-423YD	GaAsP/GaP	Yellow	Yellow Diffused	585	2.1	2.8	10.0	130
L-423ED	GaAsP/GaP	Hi. effi Red	Red Diffused	635	2.0	2.8	12.0	130
L-423SRD	GaAlAs	Super Red	Red Diffused	660	1.8	2.4	80.0	130

L-433XX 2.5x7.0x7.0mm RECTANGULAR LED LAMP

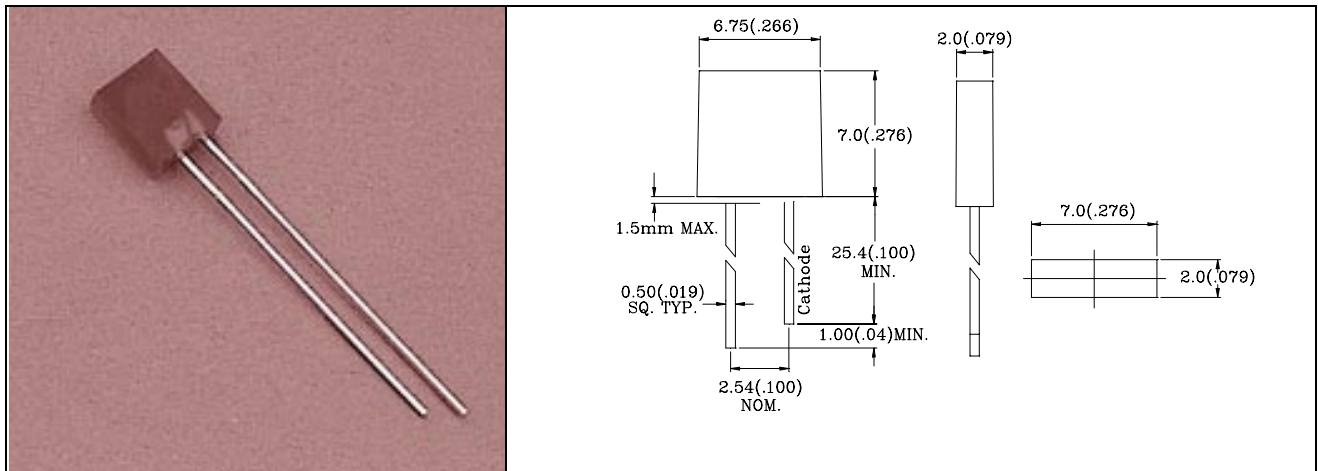

Part No.	Chip		Lens Color	Wave Length λ p(nm)	Electro-Optical Characteristics			View Angle (deg)
	Raw Material	Emitted Color			Vf(V)20mA		Iv(mcd)10mA	
					Typ.	Max.	Typ.	
L-433HD	GaP	Red	Red Diffused	700	2.1	2.8	5.0	130
L-433GD	GaP	Green	Green Diffused	565	2.1	2.8	10.0	130
L-433YD	GaAsP/GaP	Yellow	Yellow Diffused	585	2.1	2.8	10.0	130
L-433ED	GaAsP/GaP	Hi. effi Red	Red Diffused	635	2.0	2.8	12.0	130
L-433SRD	GaAlAs	Super Red	Red Diffused	660	1.8	2.4	80.0	130

1. All dimension are in millimeters (inches).

2. Tolerance is ± 0.25 mm (0.01") unless otherwise specified.