

SMD Temperature Compensated Crystal Oscillator

SMD TCXO using analogue ASIC for compensation and an optional Enable/Disable pin for efficient power management.

Product description

The I(V)T2200J employs an analogue ASIC for the oscillator and a high order temperature compensation circuit in a 2.5 x 2.0 mm size package. The device can be placed in power down mode through a single input pin. During standard operation, power consumption is minimized by operating down to a supply voltage of 1.8V. The I(V)T2200J's high stability, low power consumption, small footprint and powerful compensation method makes it a TCXO ideally suited for demanding GPS mobile applications.

**Applications**

- Consumer
- Communications
- GPS
- Feature phone

Features

- Excellent phase noise performance
- Frequency slope and perturbation specifications can be customized to the application requirement
- Standard temperature stability choices are $\pm 0.5\text{ppm}$, $\pm 1\text{ppm}$, $\pm 1.5\text{ppm}$ and $\pm 2.5\text{ppm}$ over wide temperature ranges

Specifications**1.0 SPECIFICATION REFERENCES**

Line	Parameter	Description
1.1	Model description	IT2200J / IVT2200J / IT2200JP
1.2	RoHS compliant	Yes
1.3	Reference number	
1.4	Rakon part number	

2.0 FREQUENCY CHARACTERISTICS

Line	Parameter	Test Condition	Value	Unit
2.1	Frequency		10 to 52	MHz
2.2	Frequency calibration	Offset from nominal frequency measured at $25^{\circ}\text{C} \pm 2^{\circ}\text{C}$	± 1 max	ppm
2.3	Reflow shift	Two consecutive reflows as per attached profile after 1 hour recovery at 25°C	± 1 max	ppm
2.4	Temperature range	The operating temperature range over which the frequency stability is measured	-40 to 85	$^{\circ}\text{C}$
2.5	Frequency stability over temperature	Referenced to the midpoint between minimum and maximum frequency value over the specified temperature range. Control voltage set to midpont of control voltage (Note 1)	± 0.5 to 2.5	ppm
2.6	Frequency slope	Minimum of 1 frequency reading every 2°C over the operating temperature range (Note 1)	0.1 to 1	ppm/ $^{\circ}\text{C}$
2.7	Static temperature hysteresis	Frequency change after reciprocal temperature ramped over the operating range. Frequency measured before and after at 25°C	0.6 max	ppm
2.8	Sensitivity to supply voltage variations	Supply voltage varied $\pm 5\%$ at 25°C	± 0.2 max	ppm
2.9	Sensitivity to load variations	$\pm 10\%$ load change at 25°C (Note 2)	± 0.2 max	ppm
2.10	Long term stability	Frequency drift over 1 year at 25°C	± 1 max	ppm

3.0 POWER SUPPLY

Line	Parameter	Test Condition	Value	Unit
3.1	Supply voltage	Nominal supply voltage range	1.8 to 3.3	V
3.2	Current	At maximum supply voltage (Note 2)	2 max	mA

4.0 CONTROL VOLTAGE (VCO)

Line	Parameter	Test Condition	Value	Unit
4.1	Control voltage range	The nominal control voltage value is midway between the minimum and maximum. Voltage control should not exceed the supply voltage +0.2 V or GND. Supply voltage ≤ 2.3 V	0.3 to 1.5	V
4.2	Control voltage range	The nominal control voltage value is midway between the minimum and maximum. Voltage control should not exceed the supply voltage +0.2 V or GND. Supply voltage > 2.3 V	0.4 to 2.4	V
4.3	Frequency tuning	Frequency shift from minimum to maximum control voltages	± 10 min	ppm
4.4	Port input impedance	Measured between Control voltage and GND pin	500	k Ω

5.0 OSCILLATOR OUTPUT

Line	Parameter	Test Condition	Value	Unit
5.1	Output waveform	DC coupled clipped sine-wave (Note 3)		
5.2	Output voltage level	At minimum supply voltage (Note 2)	0.8 min	V
5.3	Output load resistance	Refer to test circuit. Typical load 10k Ω	9 to 11	k Ω
5.4	Output load capacitance	Refer to test circuit. Typical load 10pF	9 to 11	pF
5.5	Start up time (amplitude)	Within 90% of specified output level	0.5 max	ms
5.6	Start up time (frequency)	Within ± 0.5 ppm of steady state frequency	2 max	ms

6.0 POWER DOWN MODE (Enable/Disable Pin)

Line	Parameter	Test Condition	Value	Unit
6.1	Power down	RF, Disabled (Minimum GND)	20 max	%Vcc
6.2	Normal operating mode	RF, Enabled (Maximum Vcc)	80 min	%Vcc
6.3	Stand-by current	Typical value $< 0.01\mu\text{A}$	1 max	μA
6.4	Start up time (amplitude)	Within 90% of specified output level	0.5 max	ms
6.5	Start up time (frequency)	Within ± 0.5 ppm of steady state frequency	2 max	ms

7.0 SSB PHASE NOISE

Line	Parameter	Test Condition	Value	Unit
7.1	SSB phase noise power density at 1Hz offset	Typical value for a 38.4 MHz oscillator at 25°C	-62	dBc/Hz
7.2	SSB phase noise power density at 10Hz offset	Typical value for a 38.4 MHz oscillator at 25°C	-86	dBc/Hz
7.3	SSB phase noise power density at 100Hz offset	Typical value for a 38.4 MHz oscillator at 25°C	-109	dBc/Hz
7.4	SSB phase noise power density at 1kHz offset	Typical value for a 38.4 MHz oscillator at 25°C	-132	dBc/Hz
7.5	SSB phase noise power density at 10kHz offset	Typical value for a 38.4 MHz oscillator at 25°C	-148	dBc/Hz

8.0 ENVIRONMENTAL

Line	Parameter	Description
8.1	Shock	Half sine-wave acceleration of 3000g peak amplitude. Duration: 0.3ms, Velocity: 12.3ft/s [MIL-STD-202 M213] (Note 4)
8.2	Moisture resistance	1000 hours at 85°C, 85% relative humidity. Biased. [MIL-STD-202 M106g] (Note 4)
8.3	Thermal cycling	1000 temperature cycles, where each cycle consists of a 25 minutes soak time at -40°C followed by a 25 minute soak time at 85°C, with a 60 second maximum transition time between temperatures. Air to air transition. [JESD22 METHOD JA-104C] (Note 4)
8.4	Vibration	10g peak acceleration for 20 minutes. 12 cycles in each of 3 orientations. Test from 10-2000Hz [JESD22-B103-B] (Note 4)
8.5	Storage temperature	-40 to 85°C

9.0 MARKING

Line	Parameter	Description
9.1	Type	Engraved
9.2	Line 1	[R], [XXXX]* = Frequency in MHz (e.g.: 8J00 = 8MHz, 19J2 = 19.2MHz, 100J = 100MHz)
9.3	Line 2	[o] = Pin 1, [XXX] = Internal code, and [XX] = Date code
9.4	* Frequency code	Frequency marking is only represented by the first three significant digits. For example, on an IT2200J TCXO at 16.368MHz, its frequency code marking will be 16J3

10.0 MANUFACTURING INFORMATION

Line	Parameter	Description
10.1	Reflow	Solder reflow processes as per profile attached.
10.2	Packaging description	Tape and reel. Standard packing quantity is 3000 units per reel

11.0 SPECIFICATION NOTES

Line	Parameter	Description
11.1	Note 1	Parts should be shielded from drafts causing unexpected thermal gradients. Temperature changes due to ambient air currents on the oscillator can lead to short term frequency drift
11.2	Note 2	Specified for load stated in the Oscillator Output section at 25°C
11.3	Note 3	AC-Coupled outputs require an external capacitor, $\geq 1\text{nF}$ recommended
11.4	Note 4	Frequency shift $\leq 1\text{ppm}$ after environmental conditions

Drawing Name: I(V)T2200J Model Outline

MODEL OUTLINE

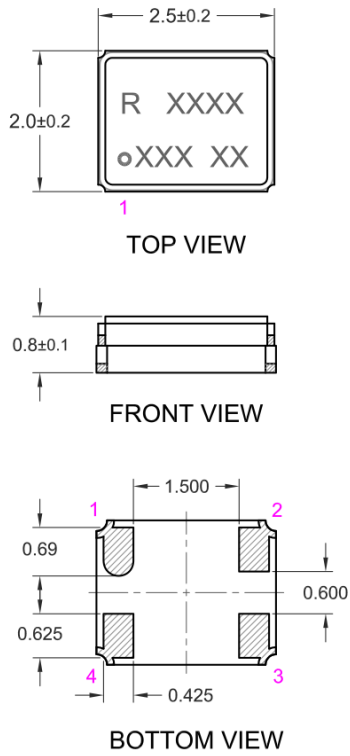

LID MARKING *

* Marking information is detailed in the specification.

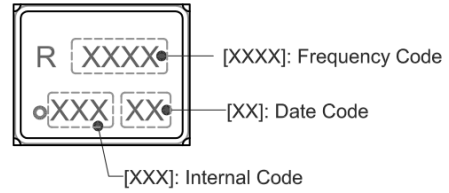

PIN CONNECTIONS

Pin	IT22..J	IVT22..J	IT22..JP
1	NC / GND	VCO	Enable / Disable**
2	GND	GND	GND
3	OUTPUT	OUTPUT	OUTPUT
4	VDD	VDD	VDD

** Connect to VDD or floating to enable TCXO.

RECOMMENDED PAD LAYOUT - TOP VIEW

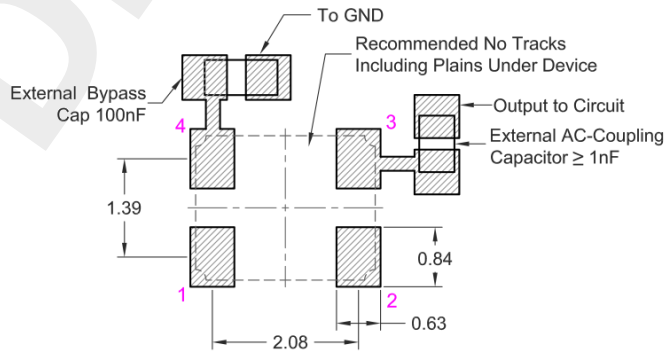

TITLE: I(V)T2200J MODEL

RELATED DRAWINGS:

FILENAME: CAT676

REVISION: D

DATE: 28-Aug-14

SCALE: 10 : 1

Millimetres

TOLERANCES:

XX =

X.X =

X.XX = ±0.10

X.XXX = ±0.05

X° =

Hole =

rakon

© 2013 Rakon Limited

Drawing Name: I(V)T2200J Series Test Circuit

IT22..J TEST CIRCUIT:

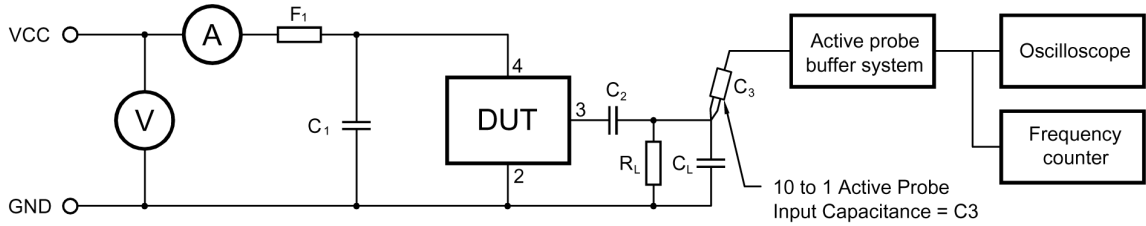

IVT22..J TEST CIRCUIT:

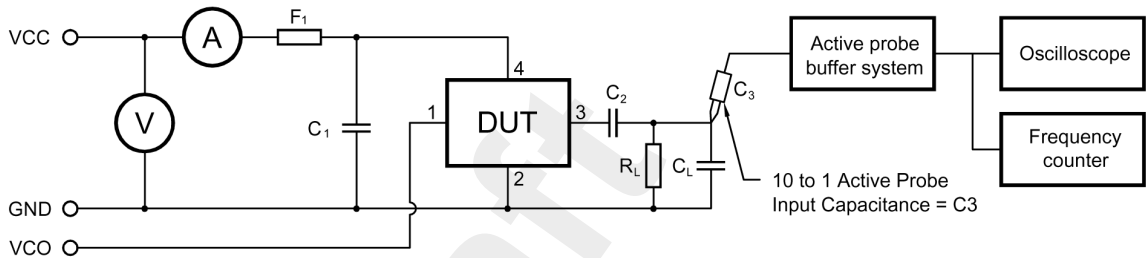

IT22..JP TEST CIRCUIT:

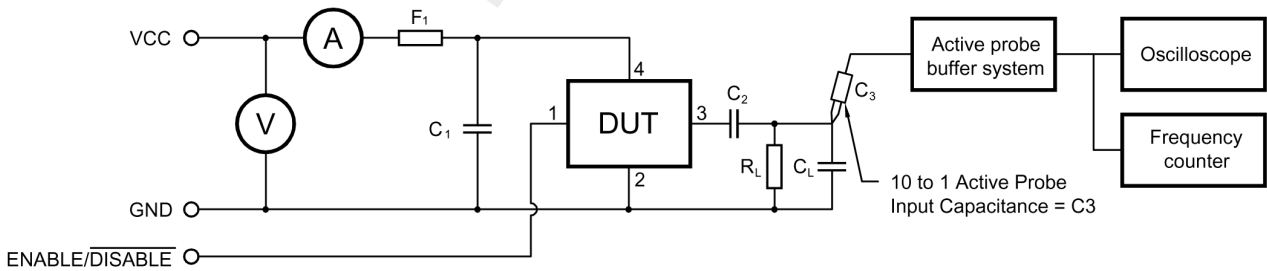

C_1 : 100nF	$C_T = C_L + C_3$ (C_3 - Oscilloscope probe capacitance)
C_2 : =1nF	C_T as stated in OSCILLATOR OUTPUT section
R_L : 10K	F_1 : A ferrite bead or a resistor between 220 ~ 470 recommended.

TITLE: I(V)T2200J SERIES TEST CIRCUIT

FILENAME: CAT677

RELATED DRAWINGS:

REVISION: A

DATE: 15-Mar-12

SCALE: 1 : 1

Millimetres [inch]

rakon

© 2009 Rakon Limited

Drawing Name: 2520 Series Tape & Reel

TAPE DETAIL (Scale 5 : 1)

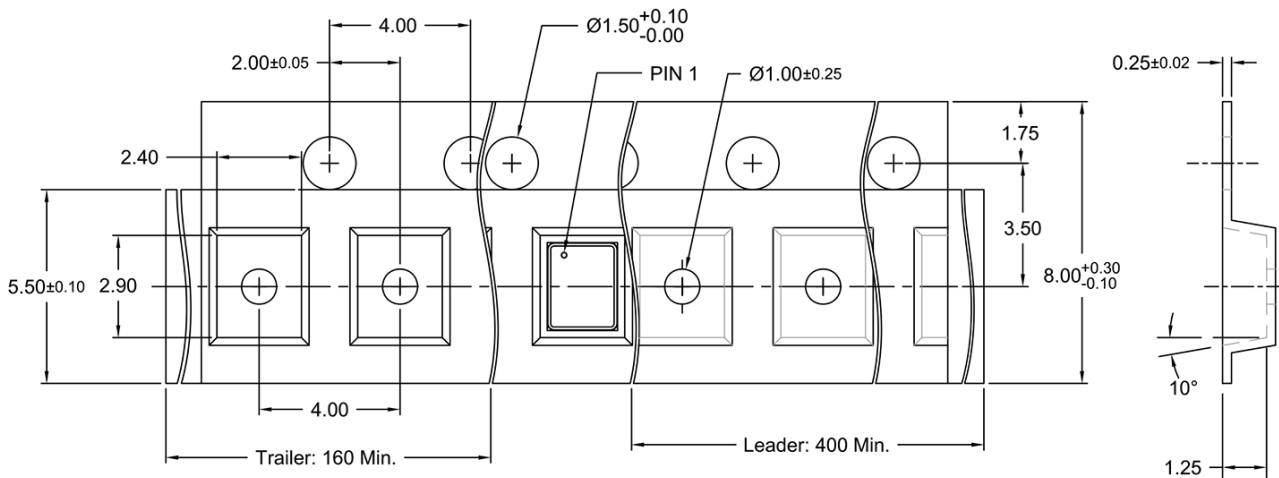

REEL DETAIL (Scale 1 : 2.5)

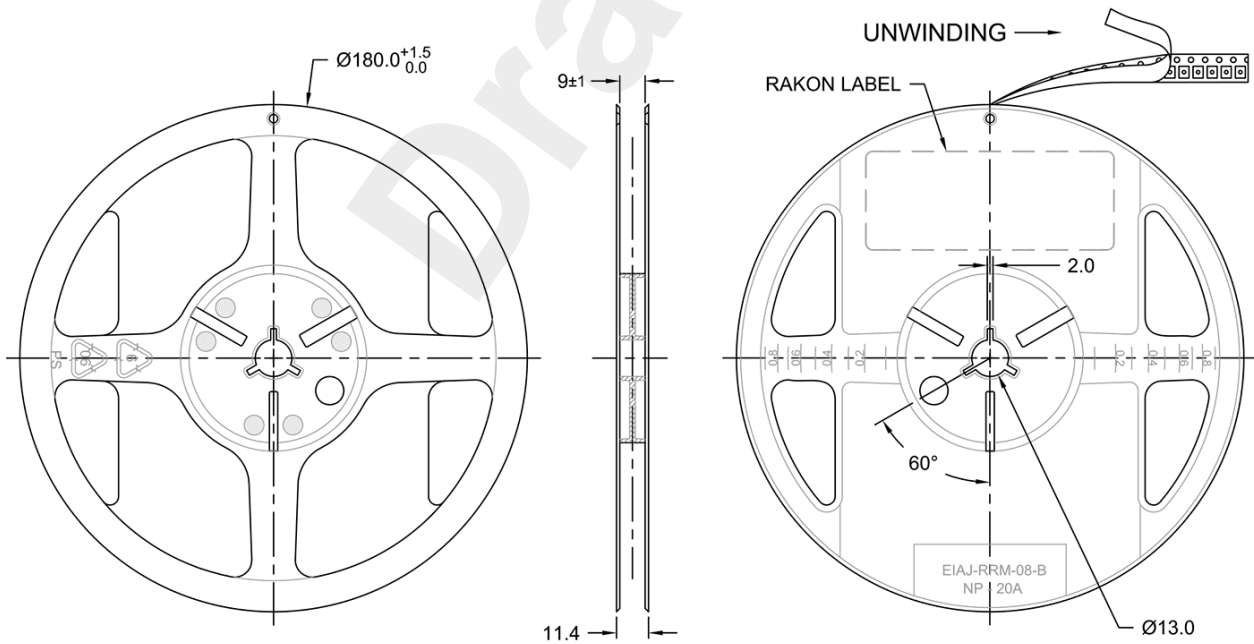

TITLE: 2520 SERIES TAPE & REEL

RELATED DRAWINGS:

FILENAME: CAT422

REVISION: F

DATE: 29-Jul-13

SCALE: See Above

Millimetres

TOLERANCES:

XX =
 X.X = ±0.1
 X.XX = ±0.05
 X.XXX =
 X° =
 Hole =

rakon

© 2013 Rakon Limited

Drawing Name: Pb-Free Reflow

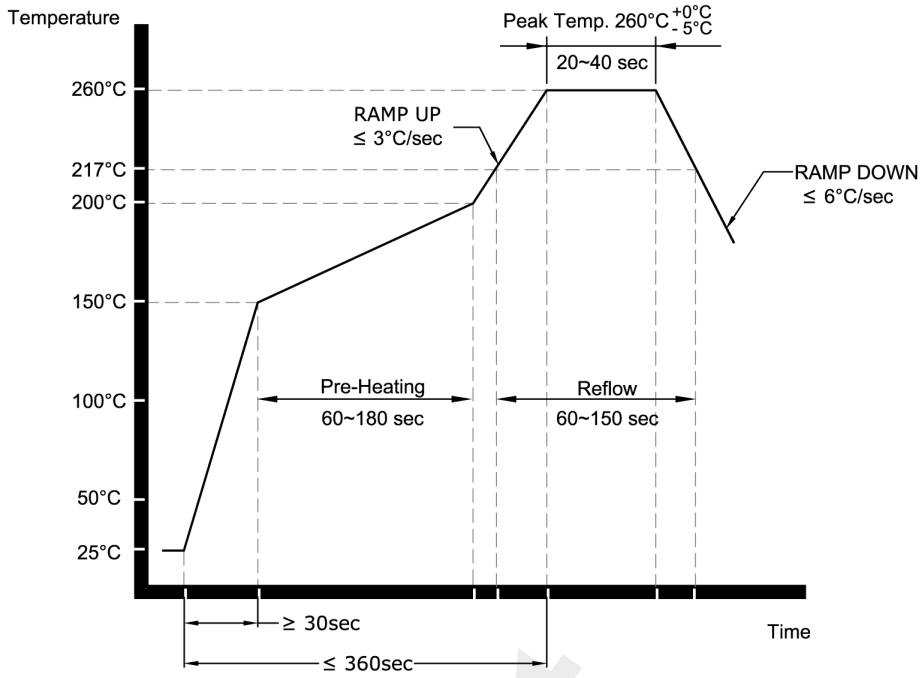

NOTE:

The product has been tested to withstand the Reflow Profile shown. The Reflow Profile used to solder Rakon products is determined by the solder paste Manufacturer's specification. It is recommended that the Reflow Profile used does not exceed the one shown above.

TITLE: Pb-FREE REFLOW

RELATED DRAWINGS:

FILENAME: CAT541

REVISION: B

DATE: 05-Sep-11

SCALE: NTS

Millimetres

rakon

© 2009 Rakon Limited