

SP3T

FEATURES

- 5 - 1000 MHz
- High Isolation
- Low DC Power
- Fast Speed 36 nSec typ.
- TTL Control
- 24 Pin DIP
- Broad Band 5 - 1000 MHz



MODEL NO. DSW32025

GaAs SP3T

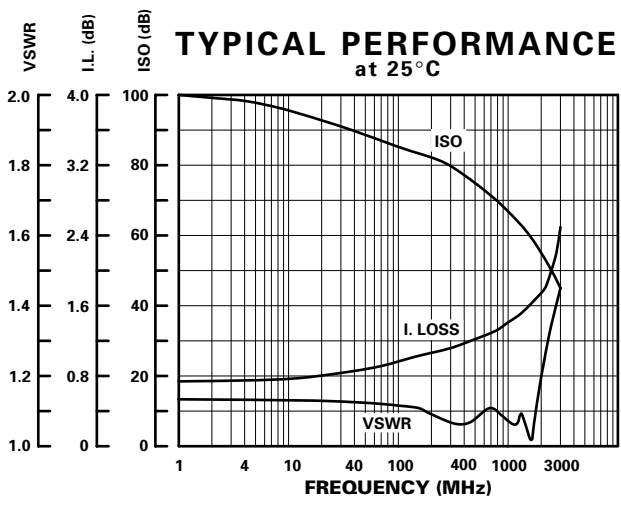
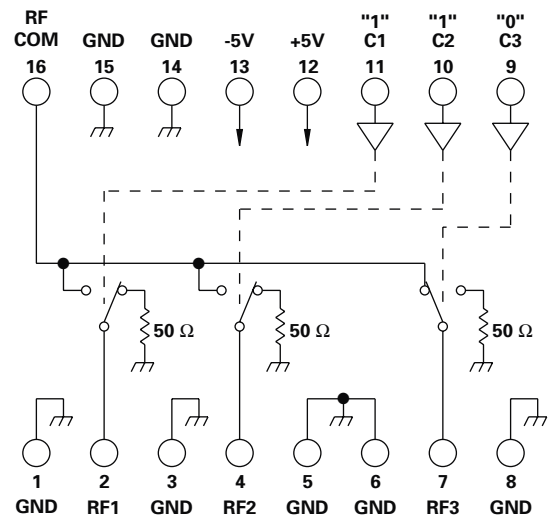
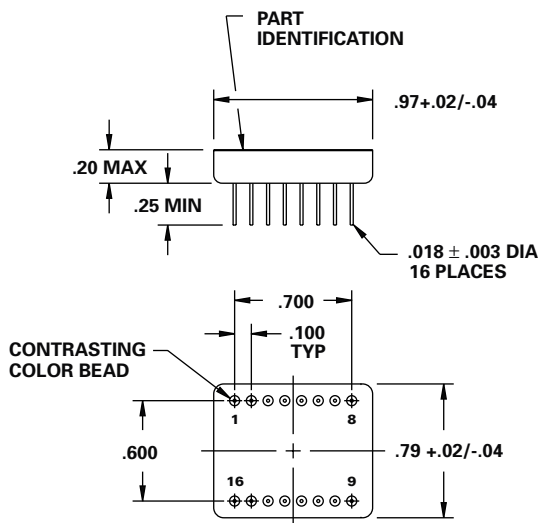

GUARANTEED PERFORMANCE

Parameter	Min	Typ	Max	Units	Conditions
Operating Frequency	5		1000	MHz	
DC Current		0.5	5	mA	At +5 VDC Supply
		0.1	2	mA	At -5 VDC Supply
Control Type		TTL			3 Lines Logic "0" = Thru
Control Current		±1.0		µA	V _{IH} = +2.7V
		±1.0		µA	V _{IL} = +0.5V
Insertion Loss		1.1	1.3	dB	5 - 500 MHz
		1.1	2	dB	500 - 1000 MHz
Isolation	70	85		dB	5 - 100 MHz
	55	75		dB	100 - 650 MHz
	50	65		dB	650 - 1000 MHz
VSWR		1.15/1	1.3/1		
		1.15/1	2.0/1		
Impedance		50		OHMS	
Switching Speed		36	100	nSEC	50% TTL to 90% / 10% RF
Transition (Rise/Fall) Time		7		nSEC	10% / 90% or 90% / 10% RF
Switching (Video) Transients		15		mV	Peak Value
Intercept Points		+70		dBm	500 30 / 200 15 MHz
	2nd				
	3rd	+30	+47	dBm	250 30 / 200 30 MHz
RF Power			+5	dBm	5 - 50 MHz
	Operate		+10	dBm	50 - 650 MHz
	No Damage		+13	dBm	650 - 1000 MHz
Operating Temperature	-54	+25	+105	°C	TA