



Features

- Tx Output Power: 22dBm
- Separate 50Ω Tx/Rx Transceiver Interface
- Rx Insertion Loss: 1dB
- Antenna Diversity Switch

Applications

- Wireless Automated Metering
- Wireless Alarm Systems
- Portable Battery Powered Equipment
- Smart Energy
- 868MHz/900MHz ISM Band Application
- Single Chip RF Front End Module

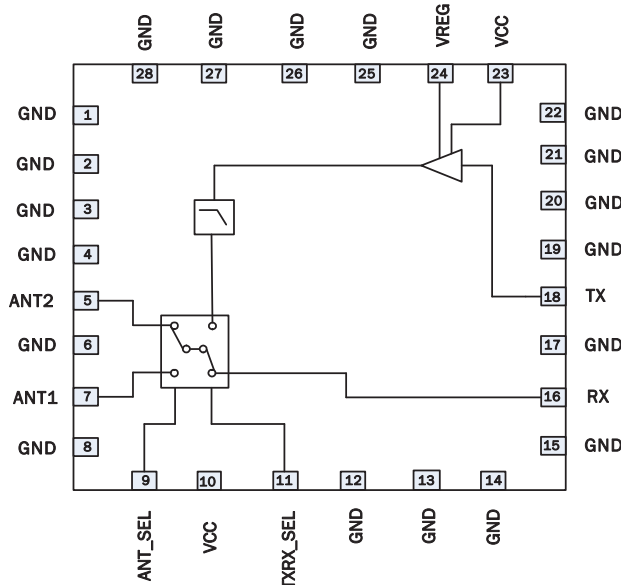

Functional Block Diagram

Product Description

This module is intended for 915MHz AMR solutions. It provides separate ports for Rx and Tx paths and two ports on the output for connecting a diversity solution or a test port. The PA section provides a nominal output power of 22dBm. The device is provided in a 5.5mm x 5.0mm, 28-pin package.

Ordering Information

RF6539	Standard 25 piece bag
RF6539SR	Standard 100 piece reel
RF6539TR7	Standard 2500 piece reel
RF6539PCBK-410	Fully Assembled Evaluation Board and 5 loose sample pieces

Absolute Maximum Ratings

Parameter	Rating	Unit
Battery Voltage	5	V
RF Port Impedance	50	Ω
Operating Temperature	-30 to 70	$^{\circ}\text{C}$
Storage Temperature	-40 to 85	$^{\circ}\text{C}$
ESD, HBM (RF pins)	500	V
ESD, HBM (All pins)	500	V
ESD, CDN (RF pins)	500	V
ESD, CDM (all pins)	500	V
MSL	MSL 3	
Maximum Input Power to PA	+10	dBm



Caution! ESD sensitive device.

Exceeding any one or a combination of the Absolute Maximum Rating conditions may cause permanent damage to the device. Extended application of Absolute Maximum Rating conditions to the device may reduce device reliability. Specified typical performance or functional operation of the device under Absolute Maximum Rating conditions is not implied.

The information in this publication is believed to be accurate and reliable. However, no responsibility is assumed by RF Micro Devices, Inc. ("RFMD") for its use, nor for any infringement of patents, or other rights of third parties, resulting from its use. No license is granted by implication or otherwise under any patent or patent rights of RFMD. RFMD reserves the right to change component circuitry, recommended application circuitry and specifications at any time without prior notice.



RoHS (Restriction of Hazardous Substances): Compliant per EU Directive 2002/95/EC.

Parameter	Specification			Unit	Condition
	Min.	Typ.	Max.		
Power Amplifier					$V_{CC} = 3.6\text{V}$, TXRX_SEL = HIGH, ANT_SEL = HIGH or LOW, $V_{REG} = 3.4\text{V}$
Frequency Range	868	902 to 928		MHz	
CW Output Power	21	22		dBm	Near Saturation
Small Signal Gain		16.5		dB	
Thermal Resistance	39.5			$^{\circ}\text{C}/\text{W}$	$3.6\text{V } V_{CC}$, $3.4\text{V } V_{REG}$, 21dBm P_{OUT} , $T_{REF} = 85^{\circ}\text{C}$
Output Harmonic Levels					
2nd	-30			dBc	
3rd through 10th	-63			dBc	
Input Return Loss	10			dBc	
Power Supply Voltage					
V_{CC}	3.3	3.6	4	V	
V_{REG}	3.1	3.4	3.8	V	$V_{REG} = V_{CC} - 0.2\text{V}$
Current					
Operating V_{CC}		100	120	mA	$V_{CC} = 3.6\text{V}$, $P_{OUT} = 22\text{dBm}$
Operating V_{REG}		3	4	mA	
Tx Idle Current		24	30	mA	$V_{CC} = 3.6\text{V}$, $V_{REG} = 3.4\text{V}$, ANT_SEL = TXRX_SEL = 3.4V at $P_{OUT} = 0\text{dBm}$

Parameter	Specification			Unit	Condition
	Min.	Typ.	Max.		
Rx Path					$V_{CC} = 3.6V$, TXRX_SEL = LOW, ANT_SEL = HIGH or LOW, $V_{REG} = LOW$
Frequency Range	868	902 to 928		MHz	
Insertion Loss		1	1.3	dB	
Input IP3	12	18		dBm	
Input Return Loss	10			dB	
Output Return Loss	10			dB	
Current					
ANT1		50		μA	ANT_SEL = HIGH, $V_{REG} = Low$, TXRX_Sel = Low
Power Down Mode, ANT2		1.7		μA	ANT_SEL = LOW, $V_{REG} = Low$, TXRX_Sel = Low
Antenna Switch and Logic					
Isolation	20			dB	Any used port to any unused port
Logic Voltage High	3.1	3.4	3.8	V	All Logic I/O's, $V_{CC} - 0.2V$
Logic Voltage Low	0		0.2	V	All Logic I/O's
Logic Current, High		85	120	μA	All Logic I/O's

Operating Mode	Module Logic Truth Table	
	ANT_SEL	TxRx_SEL
Tx - ANT1	HIGH	HIGH
Tx - ANT2	LOW	HIGH
Rx - ANT1	HIGH	LOW
Rx - ANT2	LOW	LOW

NOTE:

*Switch Control Logic High = Min 3.1V to Max 3.8V

*Switch Control Logic Low = Min 0.0V to Max 0.2V

Pin Names and Description

Pin	Name	Description
1	GND	Ground
2	GND	Ground
3	GND	Ground
4	GND	Ground
5	ANT2	Antenna 2 Output/Input
6	GND	Ground
7	ANT1	Antenna 1 Output/Input
8	GND	Ground
9	ANT_SEL	Antenna Selection Control Line
10	VCC	Diversity Switch Supply Voltage
11	TXRX_SEL	Transmit or Receive Selection Control Line
12	GND	Ground
13	GND	Ground
14	GND	Ground
15	GND	Ground
16	RX	Receive Port
17	GND	Ground
18	TX	Transmit Port
19	GND	Ground
20	GND	Ground
21	GND	Ground
22	GND	Ground
23	VCC	Power Amplifier Supply Voltage
24	VREG	Power Amplifier Supply Voltage
25	GND	Ground
26	GND	Ground
27	GND	Ground
28	GND	Ground
29	GND	Center Ground Flag

Package Drawing

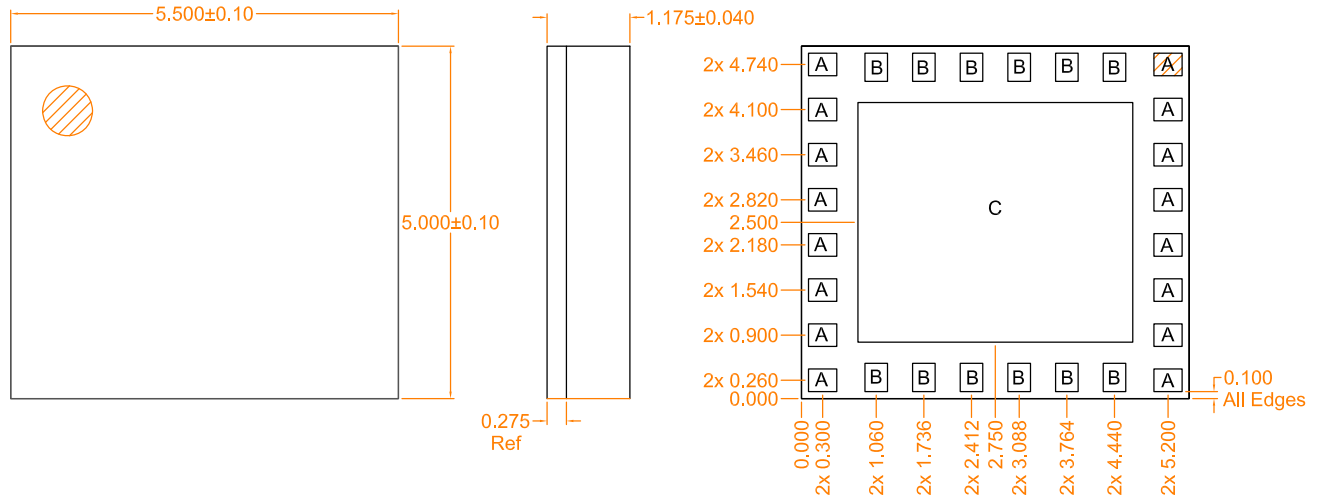

Notes:
1. Shaded area represents Pin 1 location

A = 0.400 x 0.320 mm Typ
B = 0.320 x 0.400 mm Typ
C = 3.900 x 3.400 mm

All units in μm .

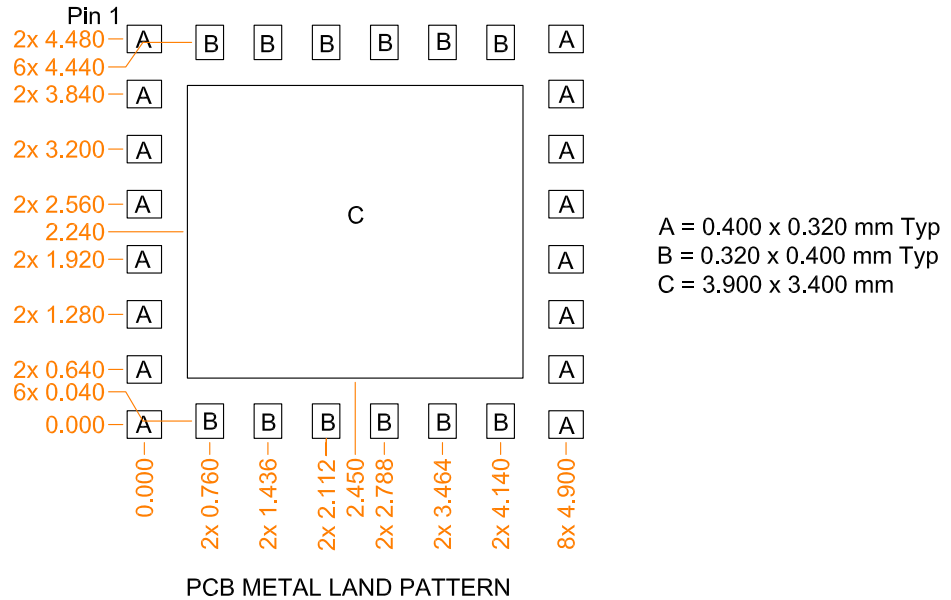

A = 0.400 x 0.320 mm Typ
B = 0.320 x 0.400 mm Typ
C = 3.900 x 3.400 mm

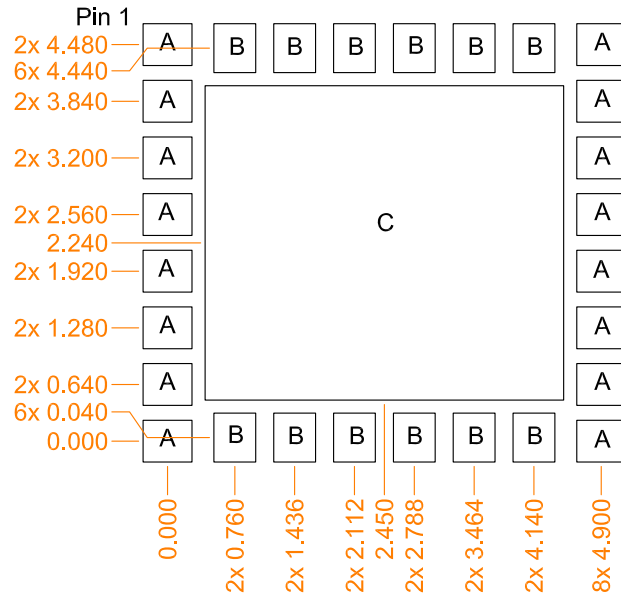

A = 0.552 x 0.472 mm Typ
 B = 0.472 x 0.552 mm Typ
 C = 4.052 x 3.552 mm

PCB SOLDER MASK PATTERN

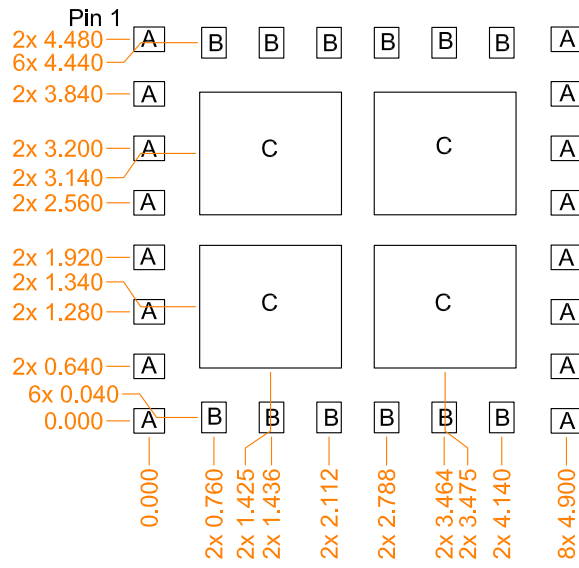

A = 0.360 x 0.288 mm Typ
 B = 0.228 x 0.360 mm Typ
 C = 1.665 x 1.440 mm Typ

PCB STENCIL PATTERN

Pin Out

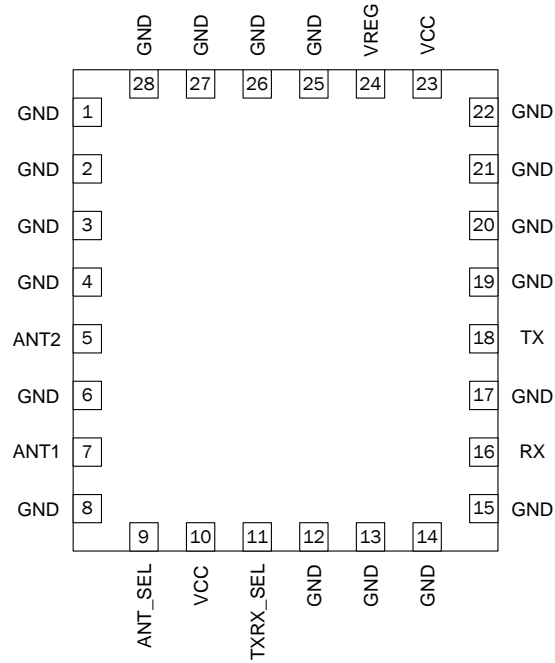

Evaluation Board Schematic

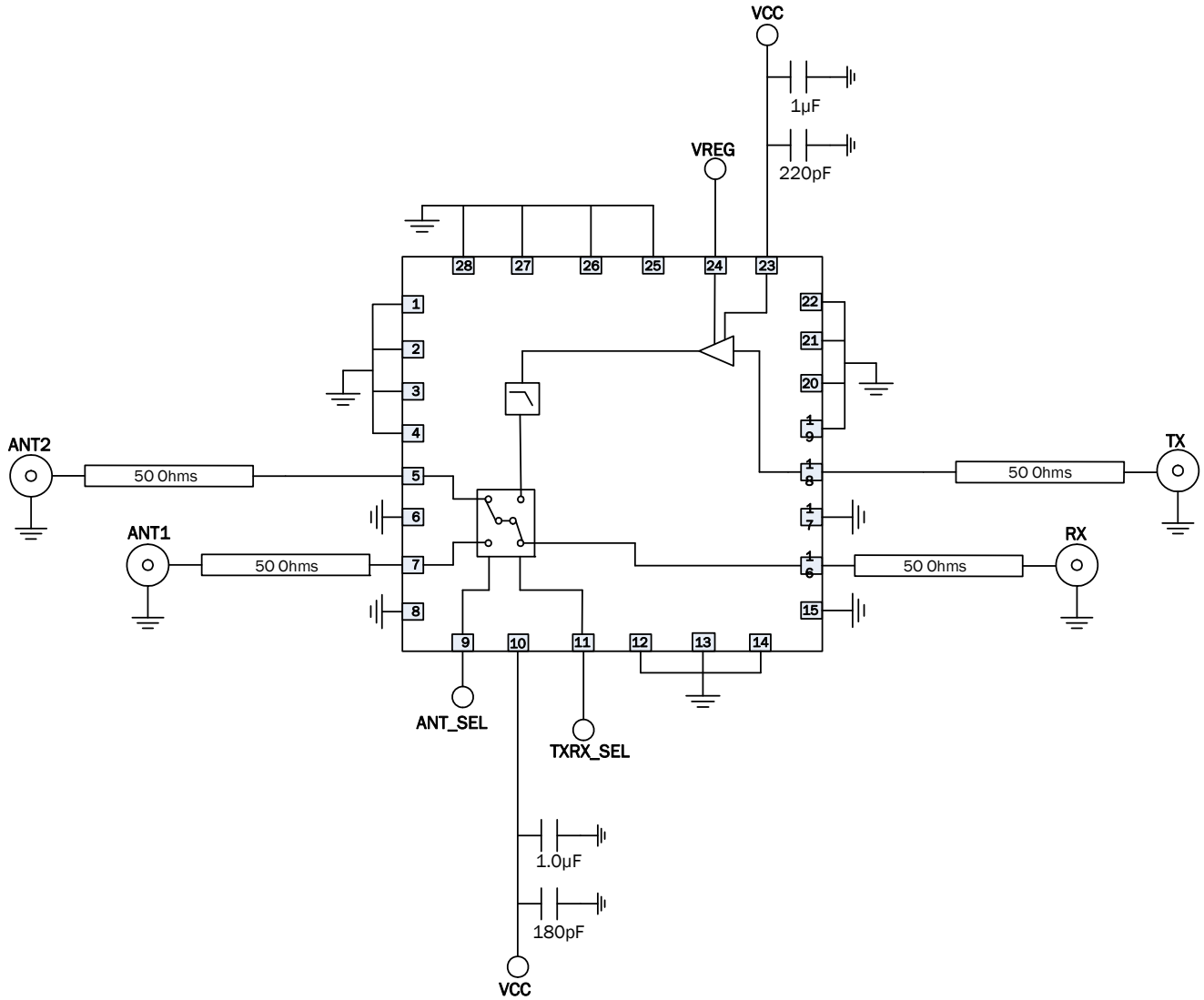

Performance Plots

