

HEXFET® Power MOSFET

V_{DSS}	80	V
$R_{DS(on) \max}$ (@ $V_{GS} = 10V$)	3.1	mΩ
Q_g (typical)	49	nC
R_g (typical)	0.9	Ω
I_D (@ $T_C(Bottom) = 25^\circ C$)	180	A

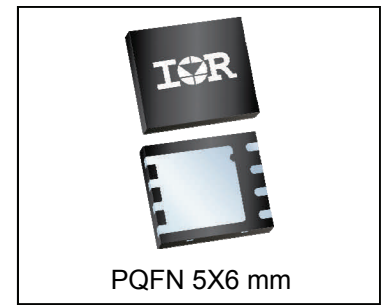
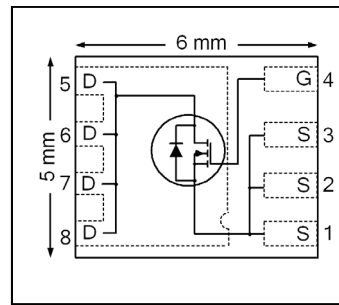

Applications

- Optimized for Secondary Side Synchronous Rectification
- Primary Switch for High Frequency 48V/60V Telecom DC-DC Power Supplies
- Hot Swap and Active O-Ring
- BLDC Motor Drive

Features

Low $R_{DS(ON)}$ (< 3.1mΩ)
Low Thermal Resistance to PCB (<0.64°C/W)
100% R_g Tested
Low Profile (<1.05 mm)
Industry-Standard Pinout
Compatible with Existing Surface Mount Techniques
RoHS Compliant, Halogen-Free
MSL1

Benefits

Lower Conduction Losses
Increased Power Density
Increased Reliability
Increased Power Density
Multi-Vendor Compatibility
Easier Manufacturing
Environmentally Friendlier
Increased Reliability

results in
⇒

Base part number	Package Type	Standard Pack		Orderable Part Number
		Form	Quantity	
IRFH7882PbF	PQFN 5mm x 6 mm	Tape and Reel	4000	IRFH7882TRPbF

Absolute Maximum Ratings

	Parameter	Max.	Units
V_{GS}	Gate-to-Source Voltage	± 20	V
$I_D @ T_A = 25^\circ C$	Continuous Drain Current, $V_{GS} @ 10V$	26	A
$I_D @ T_{C(Bottom)} = 25^\circ C$	Continuous Drain Current, $V_{GS} @ 10V$	180	
$I_D @ T_{C(Bottom)} = 100^\circ C$	Continuous Drain Current, $V_{GS} @ 10V$	114	
I_{DM}	Pulsed Drain Current ①	290	
$P_D @ T_A = 25^\circ C$	Power Dissipation	4.0	W
$P_D @ T_{C(Bottom)} = 25^\circ C$	Power Dissipation	195	
	Linear Derating Factor	0.03	W/°C
T_J T_{STG}	Operating Junction and Storage Temperature Range	-55 to + 150	°C

Notes ① through ⑤ are on page 8

Static @ T_J = 25°C (unless otherwise specified)

	Parameter	Min.	Typ.	Max.	Units	Conditions
BV _{DSS}	Drain-to-Source Breakdown Voltage	80	—	—	V	V _{GS} = 0V, I _D = 250μA
ΔBV _{DSS} /ΔT _J	Breakdown Voltage Temp. Coefficient	—	47	—	mV/°C	Reference to 25°C, I _D = 1mA
R _{DS(on)}	Static Drain-to-Source On-Resistance	—	2.5	3.1	mΩ	V _{GS} = 10V, I _D = 50A ③
V _{GS(th)}	Gate Threshold Voltage	2.0	—	3.6	V	V _{DS} = V _{GS} , I _D = 250μA
ΔV _{GS(th)}	Gate Threshold Voltage Coefficient	—	-5.1	—	mV/°C	
I _{DSS}	Drain-to-Source Leakage Current	—	—	1.0	μA	V _{DS} = 64V, V _{GS} = 0V
I _{GSS}	Gate-to-Source Forward Leakage	—	—	100	nA	V _{GS} = 20V
	Gate-to-Source Reverse Leakage	—	—	-100		V _{GS} = -20V
g _{fs}	Forward Transconductance	104	—	—	S	V _{DS} = 25V, I _D = 50A
Q _g	Total Gate Charge	—	49	74	nC	V _{DS} = 40V V _{GS} = 10V I _D = 50A
Q _{gs1}	Pre-V _{th} Gate-to-Source Charge	—	9.8	—		
Q _{gs2}	Post-V _{th} Gate-to-Source Charge	—	3.4	—		
Q _{gd}	Gate-to-Drain Charge	—	16	—		
Q _{godr}	Gate Charge Overdrive	—	20	—		
Q _{sw}	Switch Charge (Q _{gs2} + Q _{gd})	—	19.4	—		
Q _{oss}	Output Charge	—	145	—	nC	V _{DS} = 40V, V _{GS} = 0V
R _G	Gate Resistance	—	0.9	—	Ω	
t _{d(on)}	Turn-On Delay Time	—	6.6	—	ns	V _{DD} = 40V, V _{GS} = 10V I _D = 50A R _G = 1.0Ω
t _r	Rise Time	—	8.8	—		
t _{d(off)}	Turn-Off Delay Time	—	15	—		
t _f	Fall Time	—	5.6	—		
C _{iss}	Input Capacitance	—	3186	—	pF	V _{GS} = 0V V _{DS} = 40V f = 1.0MHz
C _{oss}	Output Capacitance	—	2004	—		
C _{rss}	Reverse Transfer Capacitance	—	33	—		

Diode Characteristics

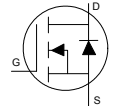
	Parameter	Min.	Typ.	Max.	Units	Conditions
I _S	Continuous Source Current (Body Diode)	—	—	180	A	MOSFET symbol showing the integral reverse p-n junction diode. 
I _{SM}	Pulsed Source Current (Body Diode) ①	—	—	290		
V _{SD}	Diode Forward Voltage	—	0.8	1.3	V	T _J = 25°C, I _S = 50A, V _{GS} = 0V ③
t _{rr}	Reverse Recovery Time	—	64	96	ns	T _J = 25°C, I _F = 50A, V _{DD} = 40V
Q _{rr}	Reverse Recovery Charge	—	116	174	nC	di/dt = 100A/μs ③

Avalanche Characteristics

	Parameter	Typ.	Max.	Units
E _{AS} (Thermally limited)	Single Pulse Avalanche Energy ②	—	704	mJ
I _{AR}	Avalanche Current ①	—	38	A

Thermal Resistance

	Parameter	Typ.	Max.	Units
R _{θJC} (Bottom)	Junction-to-Case ④	—	0.64	°C/W
R _{θJC} (Top)	Junction-to-Case ④	—	15	
R _{θJA}	Junction-to-Ambient ⑤	—	31	
R _{θJA} (<10s)	Junction-to-Ambient ⑤	—	19	

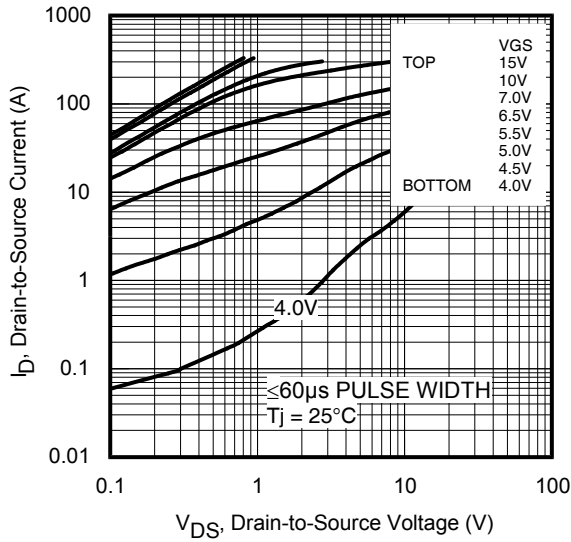
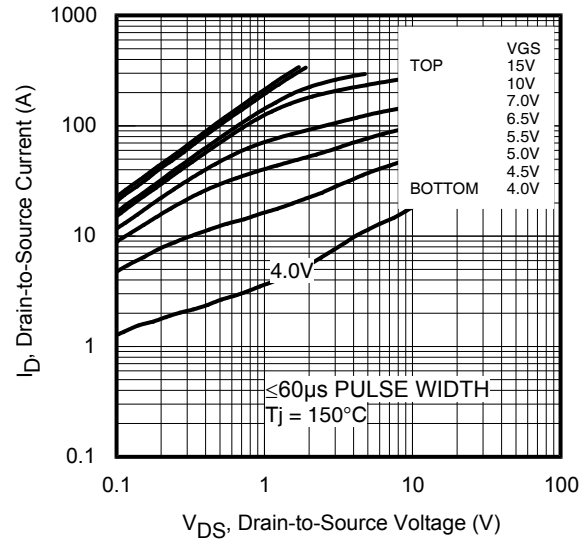
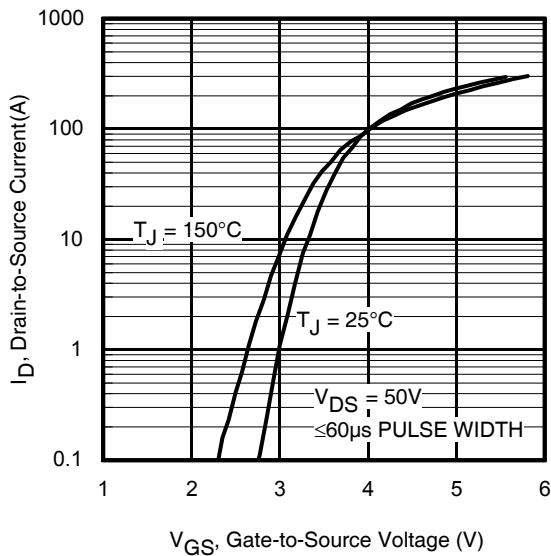
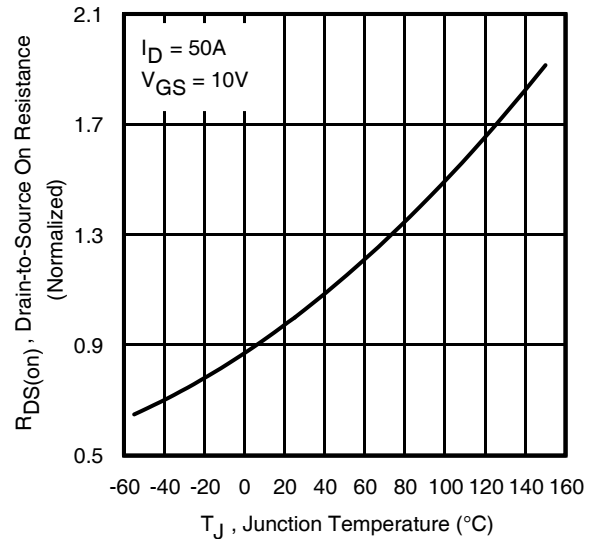
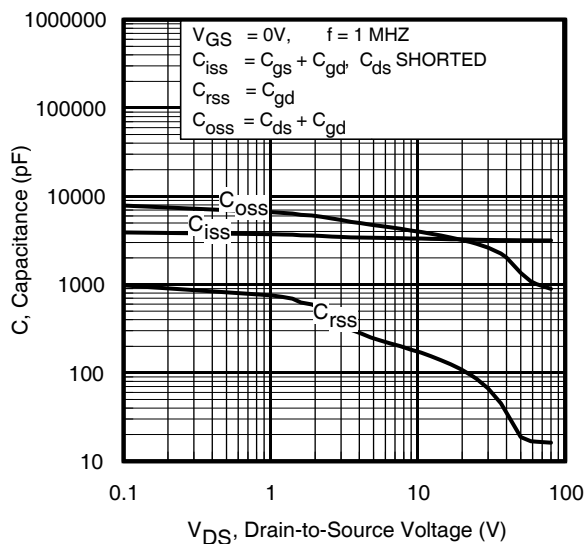
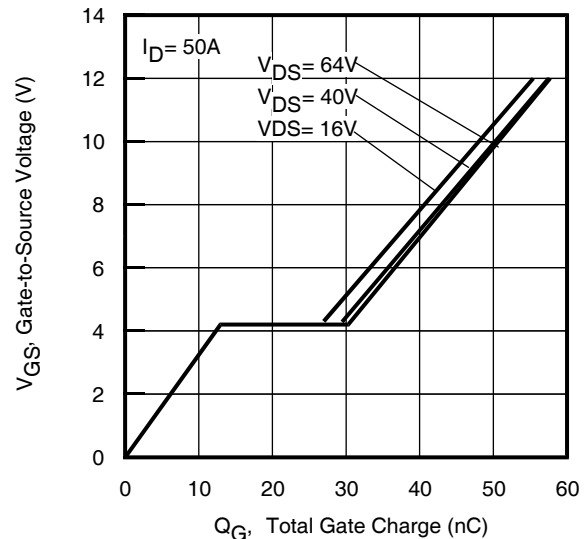
Fig 1. Typical Output Characteristics

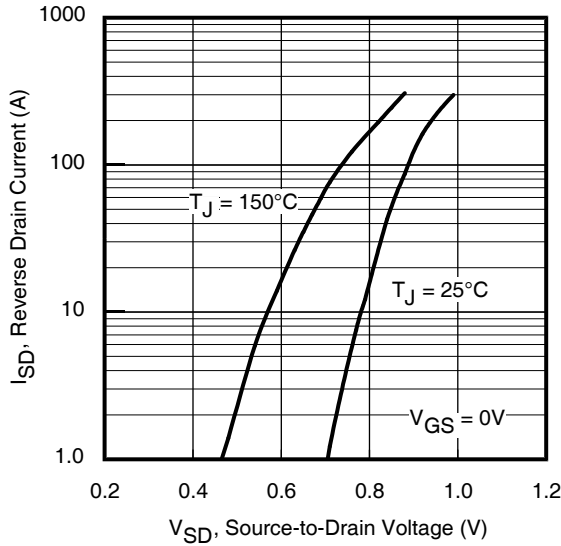
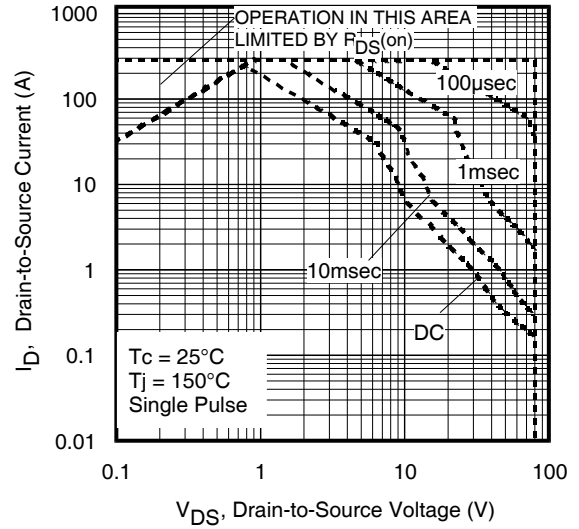
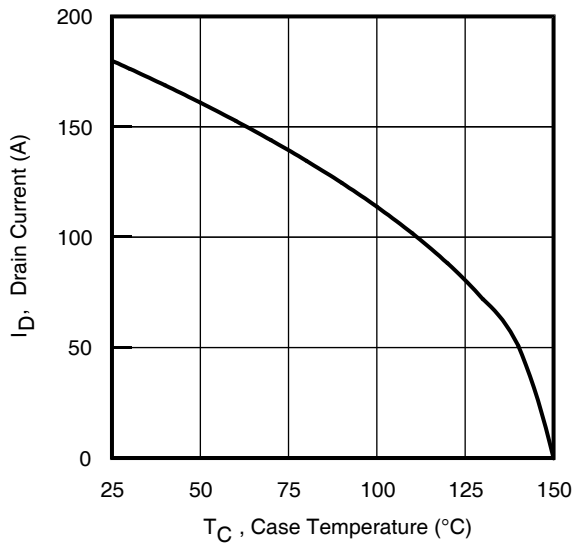
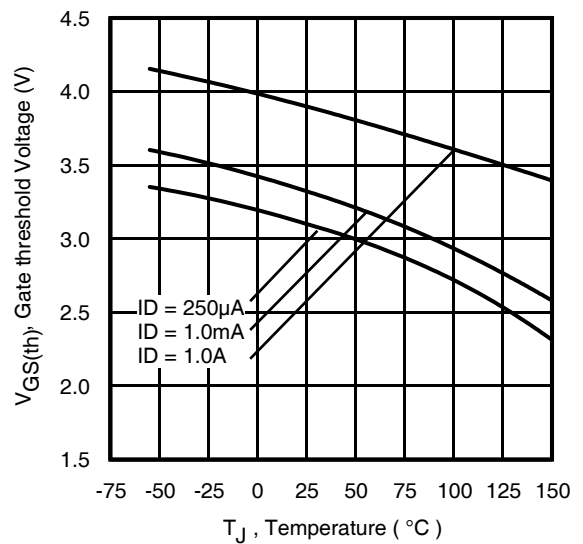
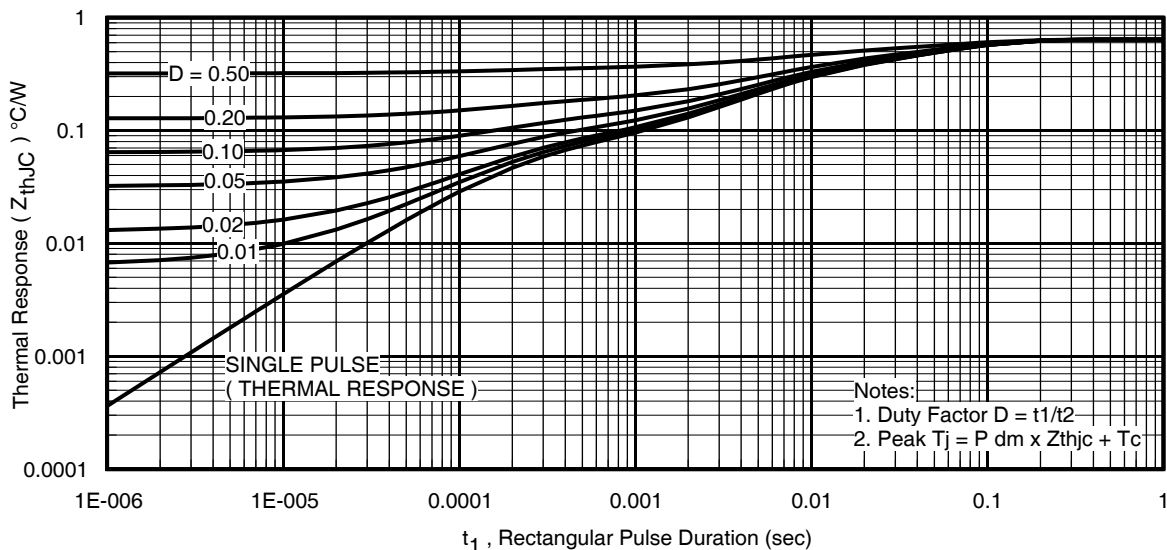
Fig 2. Typical Output Characteristics

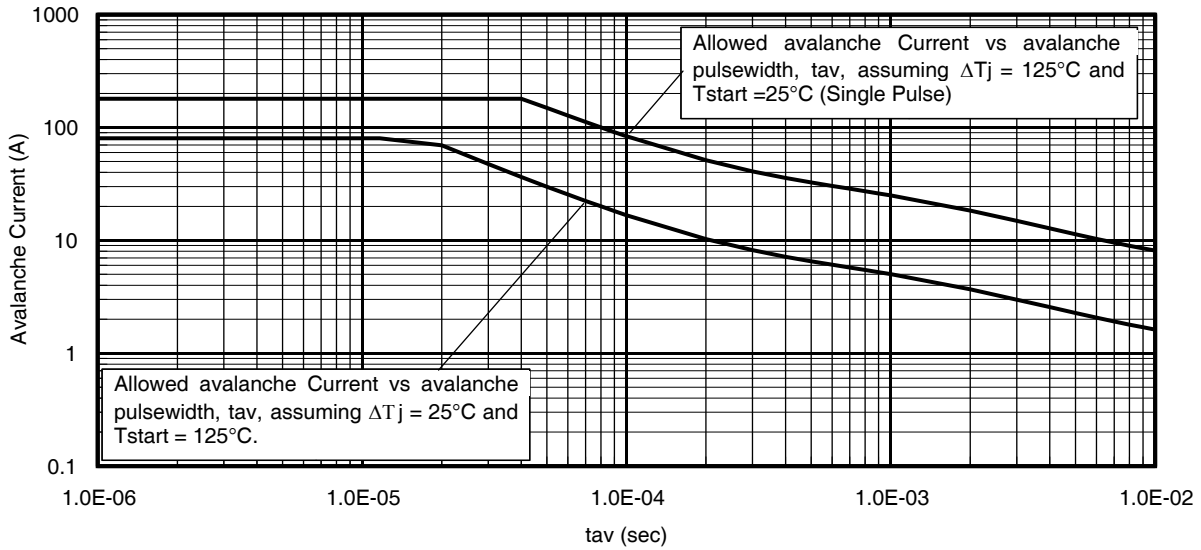
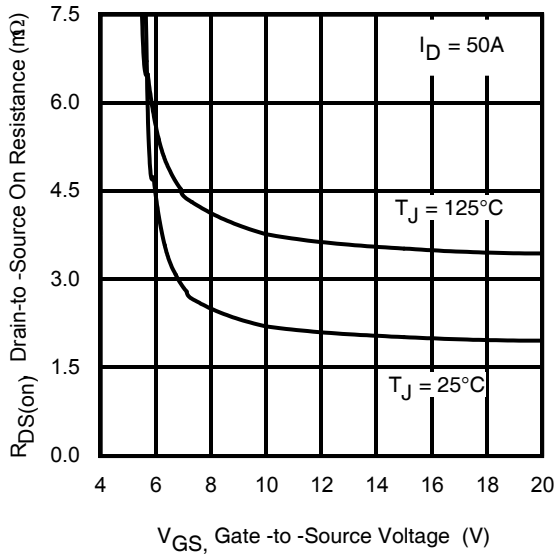
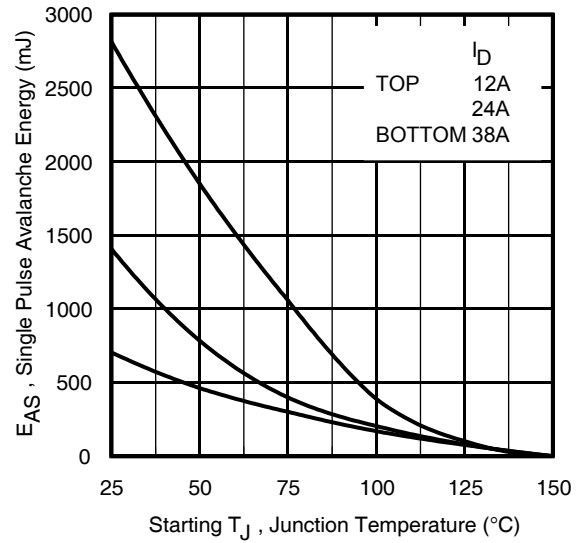
Fig 3. Typical Transfer Characteristics

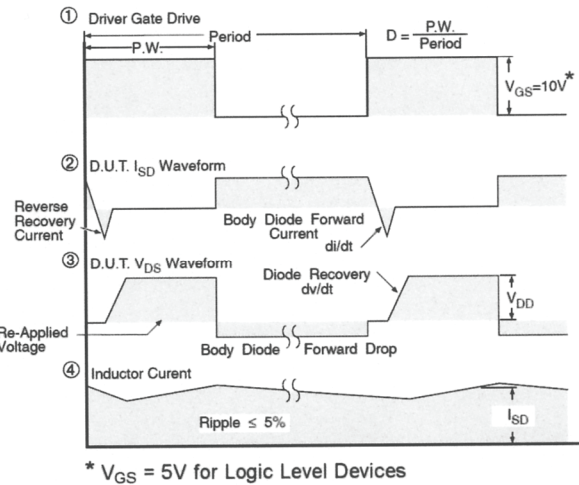
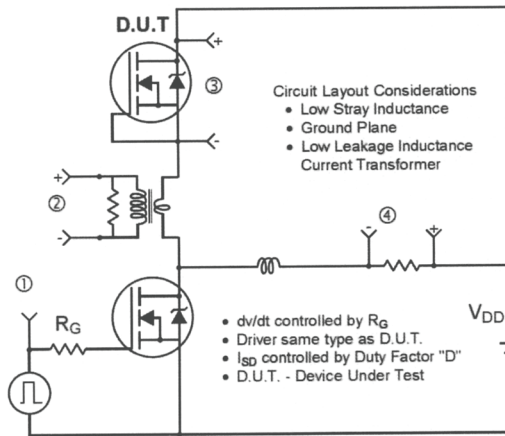
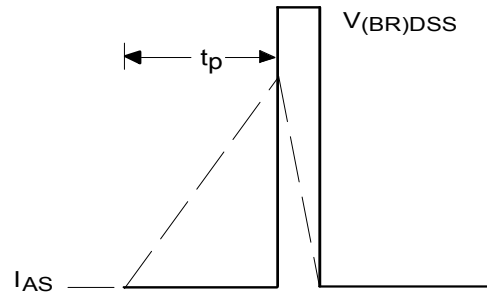
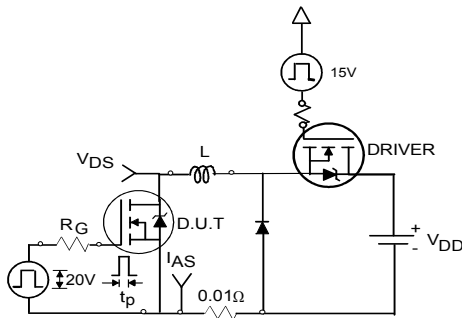
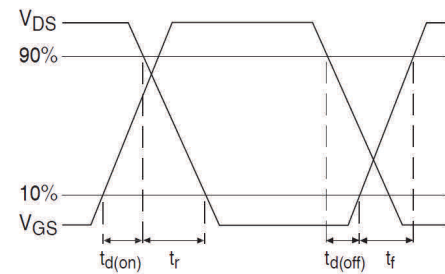
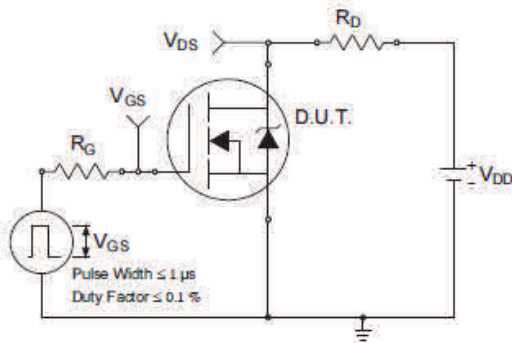
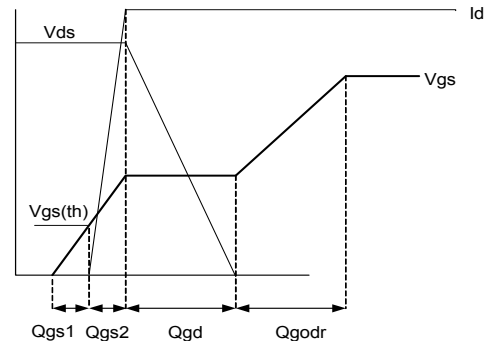
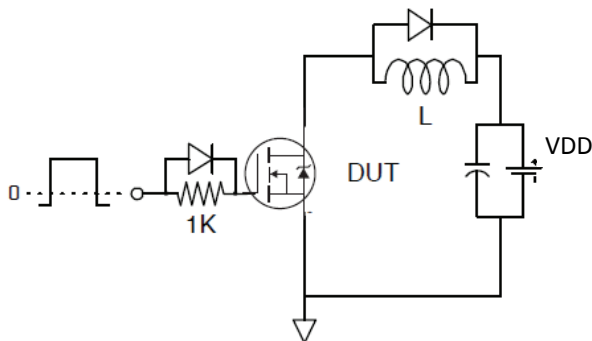
Fig 4. Normalized On-Resistance vs. Temperature

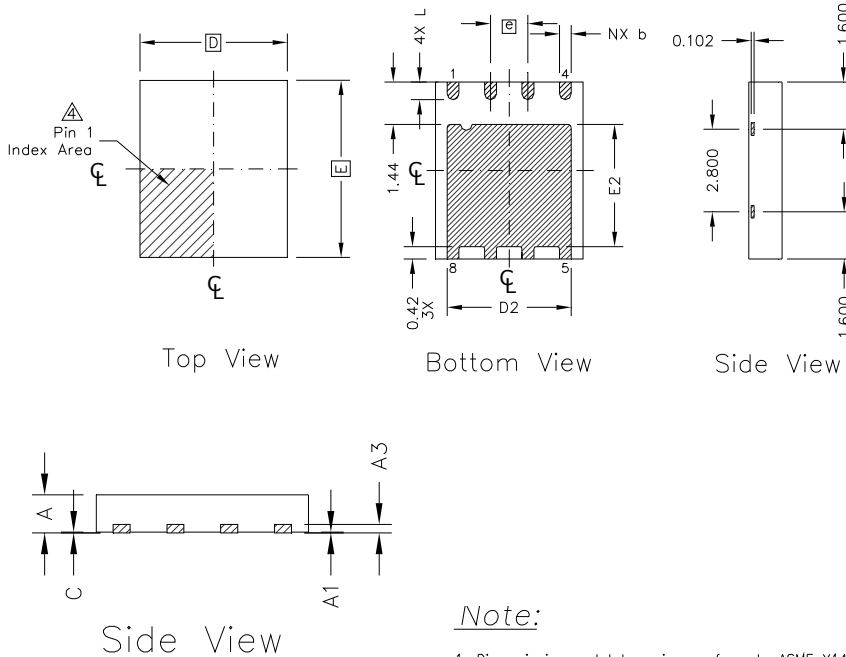
Fig 5. Typical Capacitance vs. Drain-to-Source Voltage

Fig 6. Typical Gate Charge vs. Gate-to-Source Voltage

Fig 7. Typical Source-Drain Diode Forward Voltage

Fig 8. Maximum Safe Operating Area

Fig 9. Maximum Drain Current vs. Case Temperature

Fig 10. Threshold Voltage vs. Temperature

Fig 11. Maximum Effective Transient Thermal Impedance, Junction-to-Case

Fig 12. Typical Avalanche Current vs. Pulse Width

Fig 13. On-Resistance vs. Gate Voltage

Fig 14. Maximum Avalanche Energy vs. Drain Current

Fig 15. Peak Diode Recovery dv/dt Test Circuit for N-Channel HEXFET[®] Power MOSFETs

Fig 16a. Unclamped Inductive Test Circuit
Fig 16b. Unclamped Inductive Waveforms

Fig 17a. Switching Time Test Circuit
Fig 17b. Switching Time Waveforms

Fig 18. Gate Charge Test Circuit
Fig 19. Gate Charge Waveform

PQFN 5x6 Outline "F" Package Details

SYMBOL	DIMENSIONS		
	MIN.	NOM.	MAX.
A	0.80	0.90	1.00
A1	0.000	0.02	0.05
A3	0.203 Ref		
b	0.30	0.40	0.50
D	5.00 BSC		
E	6.00 BSC		
e	1.27 BSC		
D2	4.06	4.21	4.31
E2	3.988	4.138	4.238
L	0.50	0.60	0.70
aaa	0.05		
bbb	0.10		
ccc	0.10		
ddd	0.05		
eee	0.08		
N	8		
ND	4		

Note:

1. Dimensioning and tolerancing conform to ASME Y14.5–2009.
 2. All dimensions are in millimeters.
 3. N is the total number of terminals.
 4. The location of the marked terminal #1 identifier is within the hatched area.
 5. ND refers to the maximum number of terminals on D side.
- ⚠ Dimension b applies to the metallized terminal and is measured between 0.15mm and 0.30mm from the terminal tip. If the terminal has a radius on the other end of it, dimension b should not be measured in that radius area.
- ⚠ Coplanarity applies to the terminals and all other bottom surface metallization.

For more information on board mounting, including footprint and stencil recommendation, please refer to application note AN-1136: <http://www.irf.com/technical-info/appnotes/an-1136.pdf>

For more information on package inspection techniques, please refer to application note AN-1154: <http://www.irf.com/technical-info/appnotes/an-1154.pdf>

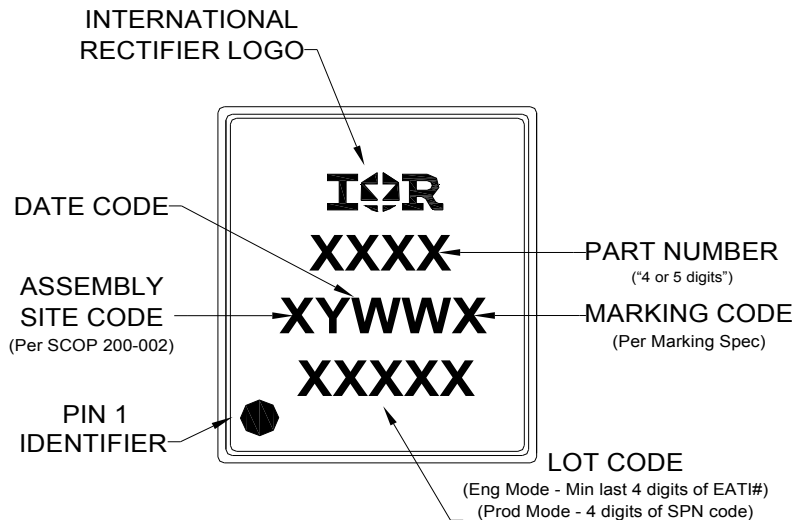
PQFN 5x6 Part Marking

Note: For the most current drawing please refer to IR website at <http://www.irf.com/package/>

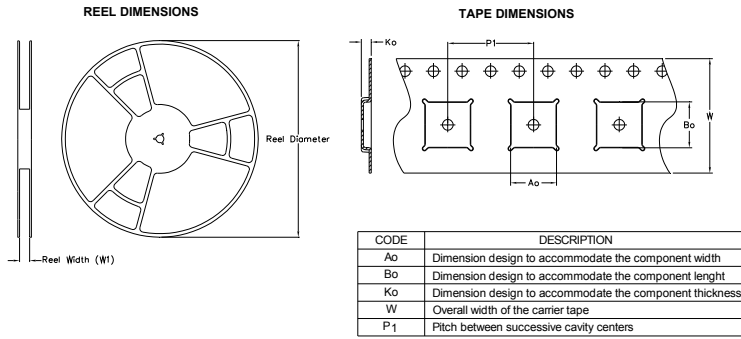
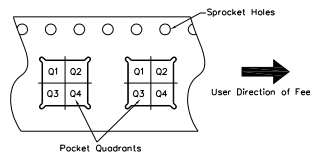
PQFN 5x6 Tape and Reel

QUADRANT ASSIGNMENTS FOR PIN 1 ORIENTATION IN TAPE

Note: All dimension are nominal

Package Type	Reel Diameter (Inch)	QTY	Reel Width W1 (mm)	Ao (mm)	Bo (mm)	Ko (mm)	P1 (mm)	W (mm)	Pin 1 Quadrant
5 X 6 PQFN	13	4000	12.4	6.300	5.300	1.20	8.00	12	Q1

 Note: For the most current drawing please refer to IR website at <http://www.irf.com/package/>
Qualification Information†

Qualification Level	Industrial (per JEDEC JESD47F†† guidelines)	
Moisture Sensitivity Level	PQFN 5mm x 6mm	MSL1 (per JEDEC J-STD-020D††)
RoHS Compliant	Yes	

 † Qualification standards can be found at International Rectifier's web site: <http://www.irf.com/product-info/reliability/>

†† Applicable version of JEDEC standard at the time of product release.

Notes:

- ① Repetitive rating; pulse width limited by max. junction temperature.
- ② Starting $T_J = 25^\circ\text{C}$, $L = 1\text{mH}$, $R_G = 50\Omega$, $I_{AS} = 38\text{A}$.
- ③ Pulse width $\leq 400\mu\text{s}$; duty cycle $\leq 2\%$.
- ④ R_q is measured at T_J of approximately 90°C .
- ⑤ When mounted on 1 inch square PCB (FR-4). Please refer to AN-994 for more details: <http://www.irf.com/technical-info/appnotes/an-994.pdf>