

PARAGON GB3225

Pre-configured DSP System for Hearing Aids

Description

The Paragon® GB3225 hybrid is a programmable DSP system based on a multi-channel compression circuit. It can be used as a platform for a wide range of hearing aid applications. Its extensive programmability and compact size make it ideal for sophisticated CIC applications. The reflowable thinSTAX® packaging enables easy integration into BTE applications. This very versatile DSP hybrid is capable of multiple configurations and has a wide range of functions.

The Paragon GB3225 hybrid contains the GC5057 controller chip featuring Power On Reset (POR).

The Paragon GB3225 hybrid code programmed into the GC5057 controller chip is “9”.

Features

- Highly Configurable, Versatile DSP Platform
- High Fidelity, Multi-channel AGC Signal Processing
- 93 dB Input Dynamic Range with HRX™ Headroom Extension
- Fully Programmable via Serial Data Interface
- High Performance Data Converters – Dual, Over-sampled A/Ds; Over-sampled D/A with Efficient Switched-mode Output Power Amp
- High-fidelity Audio Quality
- Drives Zero-bias 2-terminal Receivers
- Multiple Communication Rates up to 85.3 kb/s
- thinSTAX Packaging – CIC Size
- Multi-memory
- Internal/External Volume Control
- Volume Control Taper determined by External VC
- Tri-state Memory Select Operation
- Audible Memory Change Indicator
- Also Available as E1 RoHS Compliant Hybrid

thinSTAX Packaging

- Hybrid Typical Dimensions:
0.227 x 0.125 x 0.060 in
(5.76 x 3.18 x 1.52 mm)



ON Semiconductor®

<http://onsemi.com>

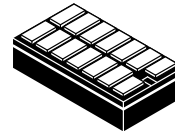

**14 PAD
PARAGON
CASE TBD**

PAD CONNECTION

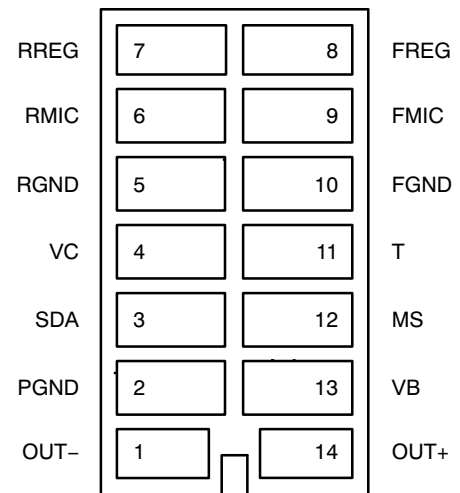

(Bottom View)

MARKING DIAGRAM

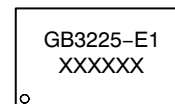

GB3225 = Specific Device Code
E1 = RoHS Compliant Hybrid
XXXXXX = Work Order Number

ORDERING INFORMATION

Device	Shipping†
GB3225-E1	25 Units / Bubble Pack

†For information on tape and reel specifications, including part orientation and tape sizes, please refer to our Tape and Reel Packaging Specification Brochure, BRD8011/D.

PARAGON GB3225

BLOCK DIAGRAM

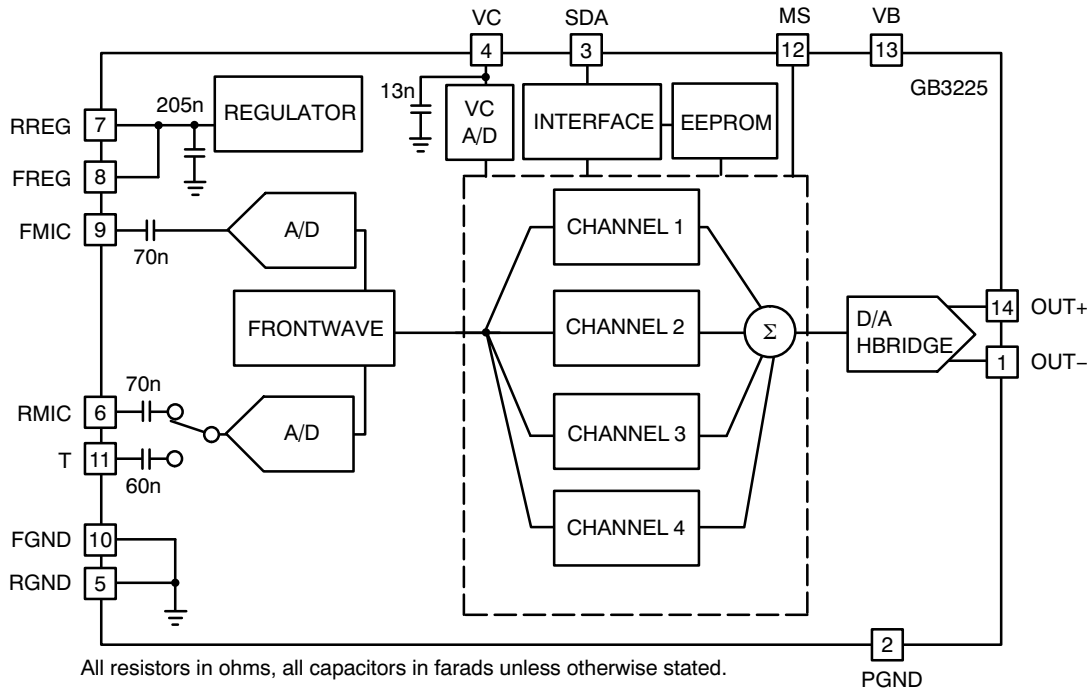

Figure 1. Paragon GB3225 Block Diagram

Table 1. ABSOLUTE MAXIMUM RATINGS

Parameter	Value	Units
Operating Temperature Range	-10 to +40	°C
Storage Temperature Range	-20 to +70	°C
Absolute Maximum Power Dissipation	25	mW
Maximum Operating Supply Voltage	1.5	VDC
Absolute Maximum Supply Voltage	2	VDC

Stresses exceeding Maximum Ratings may damage the device. Maximum Ratings are stress ratings only. Functional operation above the Recommended Operating Conditions is not implied. Extended exposure to stresses above the Recommended Operating Conditions may affect device reliability.

WARNING: Electrostatic Sensitive Device – Do not open packages or handle except at a static-free workstation.

WARNING: Moisture Sensitive Device – Non-RoHS Compliant – Level 3 MSL; RoHS Compliant – Level 4 MSL. Do not open packages except under controlled conditions.

PARAGON GB3225

Table 2. ELECTRICAL CHARACTERISTICS (Conditions: $V_B = 1.3\text{ V}$; Temperature = 25°C)

Parameter	Symbol	Conditions	Min	Typ	Max	Units
Hybrid Current	I_{AMP}	See current consumption section	-	700	-	μA
Minimum Operating Supply Voltage	V_{BOFF}	Ramp down	0.94	1.0	1.05	V
Supply Voltage Turn On Threshold	V_{BON}	Ramp up	1.06	1.10	1.16	V
Supply Voltage Hysteresis	-	-	90	100	110	mV
Supply Voltage during Communication	V_{BC}	During Communication	1.19	1.35	1.5	V
Hybrid Current during Communication	I_P	Programming (<5 ms)	-	3.7	-	mA
EEPROM Burn Cycles	-	(Note 2)	100 k	-	-	cycles
Low Frequency System Bandwidth	-	-	100	140	225	Hz
High Frequency System Bandwidth	-	-	15.2	16	16.8	kHz
Total Maximum System Gain	A_V	$V_{IN} = -95\text{ dBV}$ at 3 kHz; squelch disabled (Note 1)	81	83	85	dB
Converter Gain	A_{CONV}	A/D + D/A gain	27	29	31	dB
Total Harmonic Distortion	THD	$V_{IN} = -40\text{ dBV}$	-	0.05	1	%
THD at Maximum Input	THD _M	$V_{IN} = -15\text{ dBV}$, HRX - ON	-	1.5	3	%
Clock Frequency	f_{clk}	-	1.945	2.048	2.151	MHz

REGULATOR

Regulator Voltage	V_{REG}	-	0.90	0.95	1.00	V
Regulator Supply Rejection	PSRR _{REG}	-	-	50	-	dB

INPUT

Input Referred Noise	IRN	Bandwidth 100 Hz - 8 kHz	-	-108	-106	dBV
Input Impedance	Z_{IN}	-	11.2	16	22	k Ω
Anti-alias Filter Rejection (input referred)	-	$f = f_{clk} - 8\text{ kHz}$, $V_{IN} = -40\text{ dBV}$	-	80	-	dB
Maximum Input Level	-	-	-	-15	-	dBV
Input Dynamic Range	-	HRX - ON, Bandwidth 100 Hz - 8 kHz	-	93	-	dB
Audio Sample Rate	-	-	30.4	32	33.6	kHz
A/D Dynamic Range	-	Bandwidth 100 Hz - 8 kHz	-	86	-	dB

OUTPUT

Maximum RMS Output Voltage	-	0 dBFS $f = 1\text{ kHz}$	-3	-1	1	dBV
D/A Dynamic Range	-	Bandwidth 100 Hz - 8 kHz	80	-	-	dB
Output Impedance	Z_{OUT}	(Note 2)	-	-	20	Ω

VOLUME CONTROL

Volume Control Resistance	R_{VC}	-	160	200	240	k Ω
Volume Control Range	ΔA	-	47.5	48	48.5	dB

MS INPUT

Low State	Lo	-	0	-	$V_{REG}/3$	V
Open State	Z	-	$V_{REG}/3$	-	$2V_{REG}/3$	V
High State	Hi	-	$2V_{REG}/3$	-	V_B	V

- Total System Gain consists of: Wideband System Gain + High and Low Independent Channel Gains + Converter Gain.
Total System Gain is calibrated during Cal/Config process.
- Sample tested.

PARAGON GB3225

Table 2. ELECTRICAL CHARACTERISTICS (Conditions: $V_B = 1.3\text{ V}$; Temperature = 25°C)

Parameter	Symbol	Conditions	Min	Typ	Max	Units
SDA INPUT						
Logic 0 Voltage	-	(Note 2)	0	-	0.3	V
Logic 1 Voltage	-	(Note 2)	1	-	1.3	V
SDA OUTPUT						
Standby Pull Up Current	-	-	1.4	2	2.6	μA
Sync Pull Up Current	-	-	450	500	550	μA
Logic 0 Current (Pull Down)	-	-	225	250	275	μA
Logic 1 Current (Pull Up)	-	-	225	250	275	μA
Synchronization Time (Synchronization Pulse Width)	T_{SYNC}	Baud = 0	237	250	263	μs
		Baud = 1	118	125	132	
		Baud = 2	59	62.5	66	
		Baud = 3	29.76	31.25	32.81	
		Baud = 4	14.88	15.63	16.41	
		Baud = 5	7.44	7.81	8.20	
		Baud = 6	3.72	3.91	4.10	
		Baud = 7	1.86	1.95	2.05	

- Total System Gain consists of: Wideband System Gain + High and Low Independent Channel Gains + Converter Gain.
Total System Gain is calibrated during Cal/Config process.
- Sample tested.

Support Software

All support software for the Paragon GB3225 is available from the ON Semiconductor website at www.onsemi.com.

TYPICAL APPLICATIONS

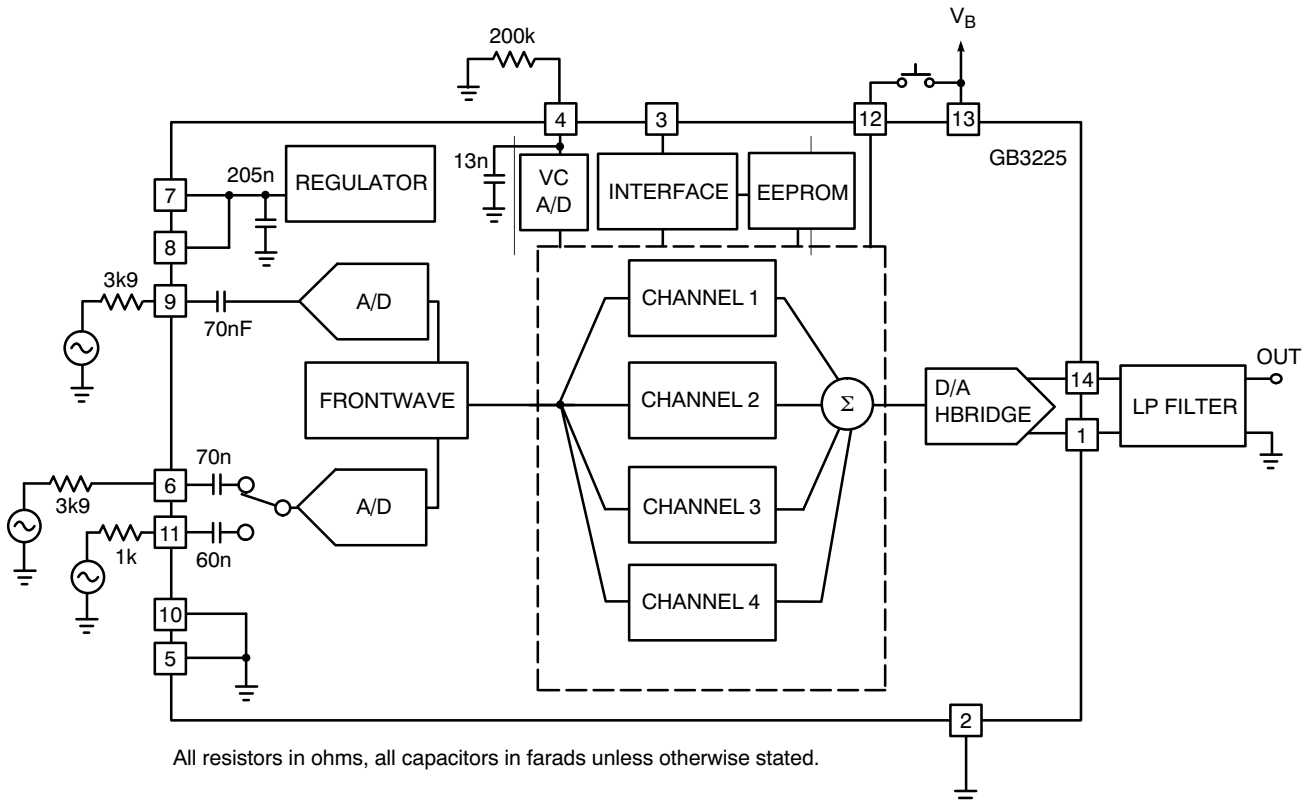

Figure 2. Test Circuit

PARAGON GB3225

TYPICAL APPLICATIONS (continued)

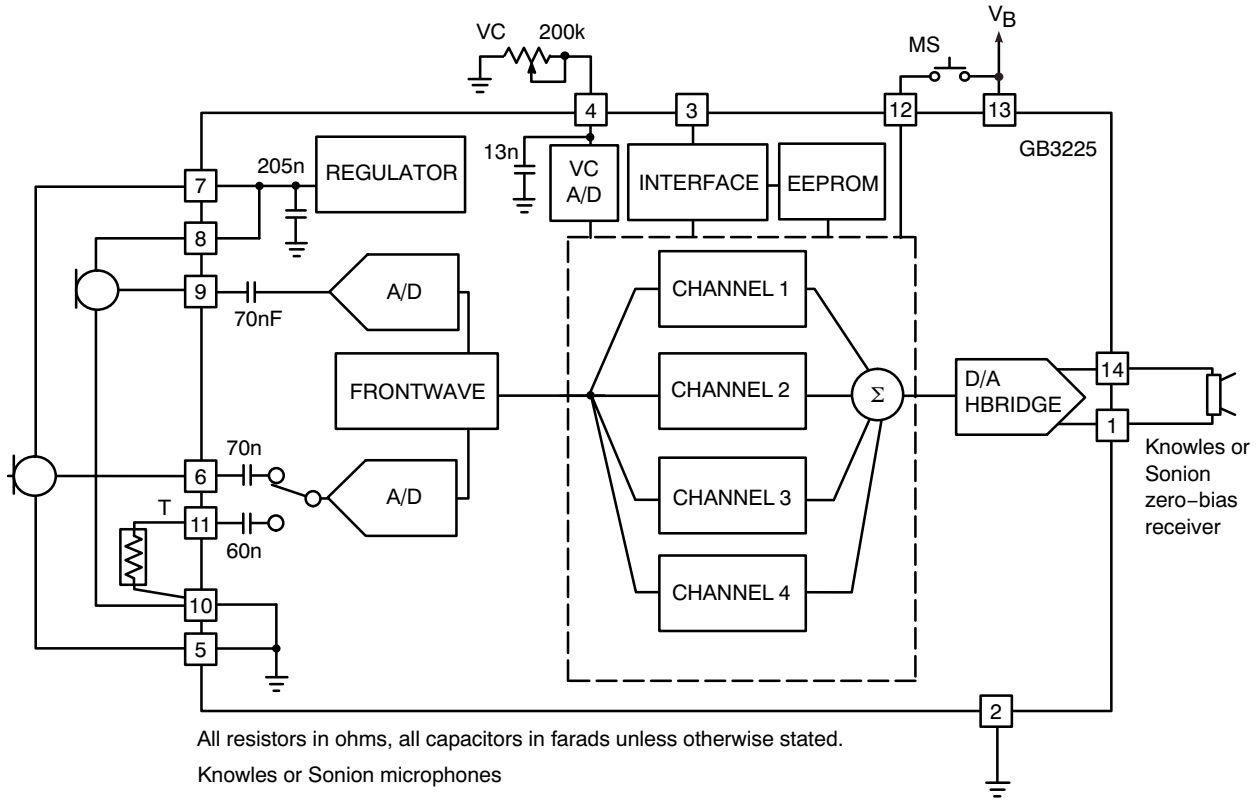

Figure 3. Sample Application Circuit

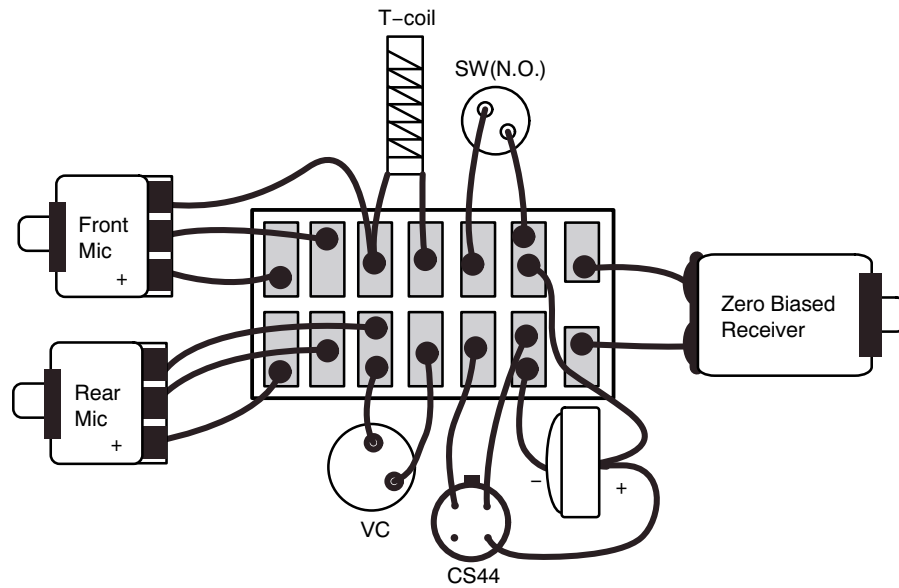

Figure 4. Assembly Diagram

PARAGON GB3225

Table 3. PAD POSITION AND DIMENSIONS

Pad No.	Pad Position		Pad Dimensions	
	X	Y	Xdim (mil)	Ydim (mil)
1	0	0	23.0	40.5
2	-31.5	3	24.0	46.5
3	-63.0	3	23.0	46.5
4	-94.0	3	23.0	46.5
5	-125.0	3	23.0	46.5
6	-156.0	3	23.0	46.5
7	-187.0	3	23.0	46.5
8	-187.0	64.5	23.0	46.5
9	-156.0	64.5	23.0	46.5
10	-125.0	64.5	23.0	46.5
11	-94.0	64.5	23.0	46.5
12	-63.0	64.5	23.0	46.5
13	-31.5	64.5	24.0	46.5
14	0	67.5	23.0	40.5
Pad No.	X	Y	Xdim (mm)	Ydim (mm)
1	0	0	0.584	1.029
2	-0.800	0.076	0.584	1.181
3	-1.600	0.076	0.584	1.181
4	-2.388	0.076	0.584	1.181
5	-3.175	0.076	0.584	1.181
6	-3.962	0.076	0.584	1.181
7	-4.750	0.076	0.584	1.181
8	-4.750	0.076	0.584	1.181
9	-3.962	1.638	0.584	1.181
10	-3.175	1.638	0.584	1.181
11	-2.388	1.638	0.610	1.181
12	-1.600	1.638	0.584	1.181
13	-0.800	1.638	0.584	1.181
14	0	1.715	0.584	1.029

PARAGON GB3225

PACKAGE DIMENSIONS

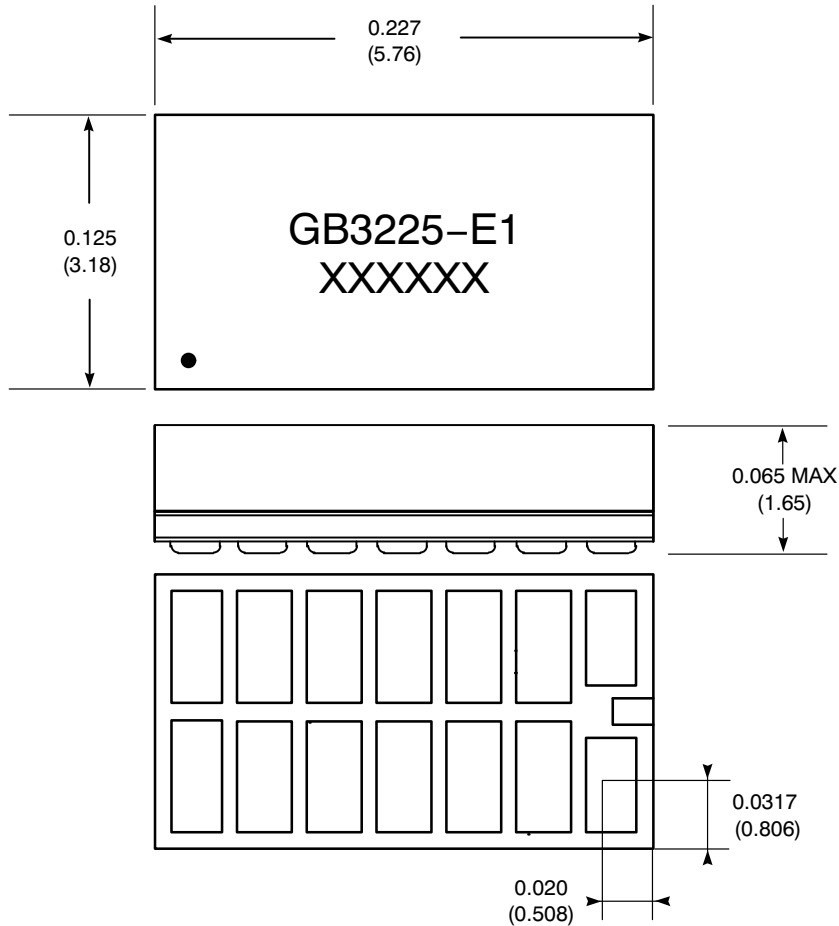

Dimension units are in inches.

Dimensions in parentheses are in millimeters, converted from inches and include minor rounding errors.

1.000 inches = 25.4 mm

Dimension tolerances: ± 0.003 (± 0.08) unless otherwise stated.

• = location of Pin 1

Work order number: XXXXXX

RoHS compliant hybrid, MSL#4,

Non-RoHS compliant hybrid, MSL#3,

This Hybrid is designed for either point-to-point manual soldering or for reflow according to ON Semiconductor's reflow process.

PARAGON and thinSTAX are registered trademarks of Semiconductor Components Industries, LLC.

HRX is a trademark of Semiconductor Components Industries, LLC.

ON Semiconductor and  are registered trademarks of Semiconductor Components Industries, LLC (SCILLC). SCILLC owns the rights to a number of patents, trademarks, copyrights, trade secrets, and other intellectual property. A listing of SCILLC's product/patent coverage may be accessed at www.onsemi.com/site/pdf/Patent-Marking.pdf. SCILLC reserves the right to make changes without further notice to any products herein. SCILLC makes no warranty, representation or guarantee regarding the suitability of its products for any particular purpose, nor does SCILLC assume any liability arising out of the application or use of any product or circuit, and specifically disclaims any and all liability, including without limitation special, consequential or incidental damages. "Typical" parameters which may be provided in SCILLC data sheets and/or specifications can and do vary in different applications and actual performance may vary over time. All operating parameters, including "Typicals" must be validated for each customer application by customer's technical experts. SCILLC does not convey any license under its patent rights nor the rights of others. SCILLC products are not designed, intended, or authorized for use as components in systems intended for surgical implant into the body, or other applications intended to support or sustain life, or for any other application in which the failure of the SCILLC product could create a situation where personal injury or death may occur. Should Buyer purchase or use SCILLC products for any such unintended or unauthorized application, Buyer shall indemnify and hold SCILLC and its officers, employees, subsidiaries, affiliates, and distributors harmless against all claims, costs, damages, and expenses, and reasonable attorney fees arising out of, directly or indirectly, any claim of personal injury or death associated with such unintended or unauthorized use, even if such claim alleges that SCILLC was negligent regarding the design or manufacture of the part. SCILLC is an Equal Opportunity/Affirmative Action Employer. This literature is subject to all applicable copyright laws and is not for resale in any manner.

PUBLICATION ORDERING INFORMATION

LITERATURE FULFILLMENT:

Literature Distribution Center for ON Semiconductor
P.O. Box 5163, Denver, Colorado 80217 USA

Phone: 303-675-2175 or 800-344-3860 Toll Free USA/Canada

Fax: 303-675-2176 or 800-344-3867 Toll Free USA/Canada

Email: orderlit@onsemi.com

N. American Technical Support: 800-282-9855 Toll Free
USA/Canada

Europe, Middle East and Africa Technical Support:
Phone: 421 33 790 2910

Japan Customer Focus Center
Phone: 81-3-5817-1050

ON Semiconductor Website: www.onsemi.com

Order Literature: <http://www.onsemi.com/orderlit>

For additional information, please contact your local
Sales Representative