

SUGGESTED PANEL CUTOUT

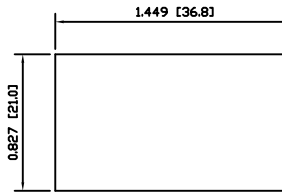
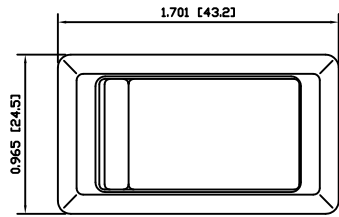

MATERIALS

- BODY:  
Phenolic (PF), UL94 V-2
- ACTUATOR:  
Polyamide 6/6 (PA66), UL94 V-2  
Brass
- SEALING MEMBRANE:  
Polyvinyl Chloride (PVC)
- SPRING:  
Plano Wire
- MOBILE CONTACT:  
Silver Plated Copper
- CONTACTS:  
Silver Clad Copper
- RIVETS:  
Copper
- TERMINALS:  
Brass

SPECIFICATIONS

- FUNCTION:  
2P1T OFF-(ON)
- RATINGS:  
ANSI/UL 508 and CAN/CSA C22.2 No.14 (E195908):  
20A 125VAC [cURus]  
15A 277VAC [cURus]  
2HP 125/250VAC [cURus]
- CONTACT RESISTANCE:  
Initial: 50mΩ Max. at 50VAC
- ELECTRICAL LIFE:  
6,000 Cycles [cURus]
- TEMPERATURE:  
Operating: -20°C to 55°C [cURus]
- INGRESS PROTECTION:  
IP54
- APPROVALS:  
 **RoHS COMPLIANT**

COLORS AND MARKINGS

- BODY COLOR:  
Black
- ACTUATOR COLOR:  
White
- MARKINGS:  
None
- MARKING COLOR:  
None

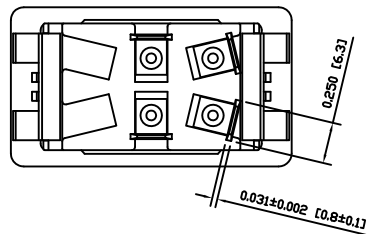
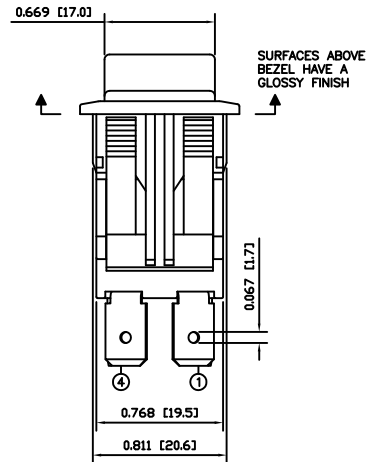
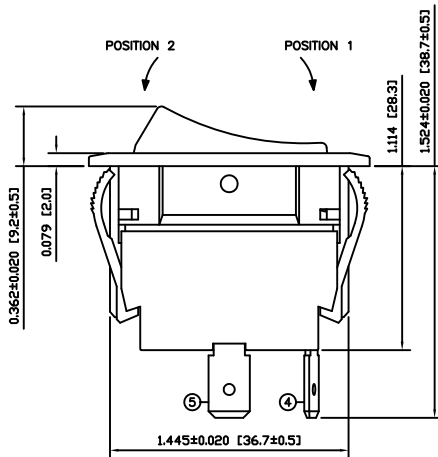

SCHEMATIC



ACTUATOR	A	09/06/11	CAB
BODY	A	09/06/12	CAB
COLORS	A	09/07/28	CAB
MATERIALS	A	09/06/15	CAB
SPECIFICATIONS	A	09/07/28	CAB
REFERENCE	REV.	DATE	BY

THE INFORMATION CONTAINED IN THIS DOCUMENT IS PROPRIETARY TO E-SWITCH AND IS NOT TO BE COPIED OR TRANSFERRED

A	INITIAL RELEASE	PCRD0050	09/07/28	CAB
REV.	DESCRIPTION	PCR	DATE	DRAWN BY

DIMENSIONS	INCHES [MILLIMETERS]
GENERAL TOLERANCES	±0.008 [±0.2] / ±1°
SCALE	DRAWING NOT TO SCALE

RWG4ED1200		
DRAWING NUMBER	DATE	REVISION
34-RWG4ED1200	JULY 28, 2009	A