



SOT502B

CDFM2; blister pack; standard product orientation 12NC ending 112

Rev. 1 — 30 November 2012

Packing information

1. Packing method

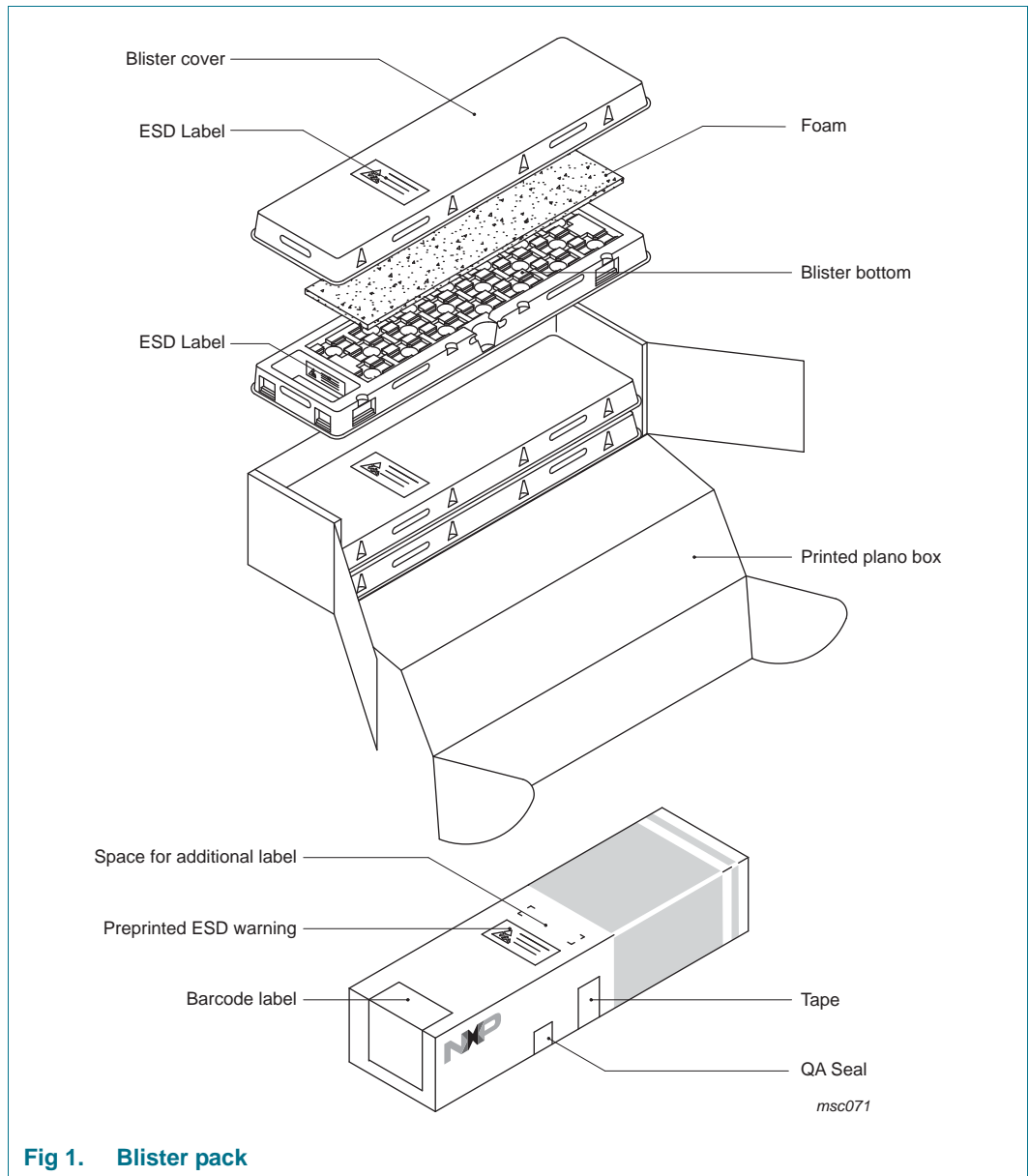

Fig 1. Blister pack



Table 1. Packing information

Package version	12NC ending	SPQ per carrier	PQ (pcs)	Carriers per box	Outer box dimensions l x w x h (mm)
SOT502B	112	20	60	3	315 x 118 x 78

Limited warranty and liability

Information in this document is believed to be accurate and reliable. However, NXP Semiconductors does not give any representations or warranties, expressed or implied, as to the accuracy or completeness of such information and shall have no liability for the consequences of use of such information.

© NXP B.V. 2012.

For more information, please visit: <http://www.nxp.com>
For sales office addresses, please send an email to: salesaddresses@nxp.com

All rights reserved.

Date of release: 30 November 2012
Document identifier: SOT502B_112