

PE9302

Product Description

The PE9302 is a high performance monolithic CMOS prescaler with a fixed divide ratio of 4. Its operating frequency range is 1.5 GHz to 3.5 GHz. The PE9302 operates on a nominal 3 V supply and draws only 14 mA. It is packaged in a small 8-lead flat pack and is ideal for space applications.

The PE9302 is manufactured in Peregrine's patented Ultra Thin Silicon (UTSi®) CMOS process, offering the performance of GaAs with the economy and integration of conventional CMOS.

3.5 GHz Low Power CMOS Divide-by-4 Prescaler For RAD-Hard Applications

Features

- High-frequency operation: 1.5 GHz to 3.5 GHz
- Fixed divide ratio of 4
- Low-power operation: 14 mA typical @ 3 V across frequency
- Small package: 8-lead formed flat pack

Product Benefits

- SEL Immune due to UTSi CMOS
- SEU $<10^{-10}$ errors / bit-day
- 100 Krads (Si) Total Dose

Figure 1. Package Drawing

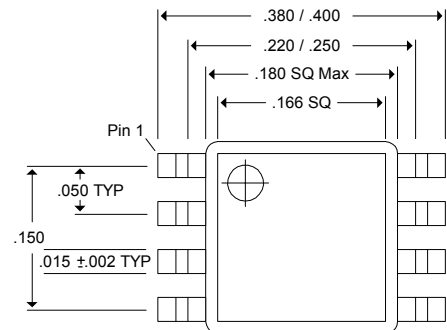
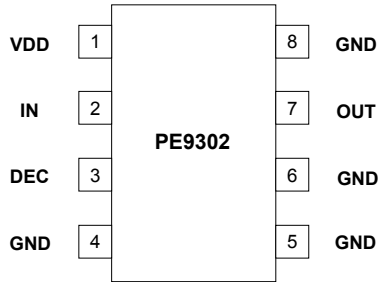

Table 1. Electrical Specifications @ +25 °C ($Z_S = Z_L = 50 \Omega$)

Parameter	Minimum	Typical	Maximum	Units
Supply Voltage	2.85	3.0	3.15	V
Supply Current		14	17	mA
Input Frequency (F_{IN})	1.5		3.5	GHz
Input Power (P_{IN})	-10		+5	dBm
Output Power	-5			dBm

Figure 2. Pin Configuration

Table 2. Pin Descriptions

Pin No.	Pin Name	Description
1	VDD	Power supply pin. Bypassing is required.
2	IN	Input signal pin. Should be coupled with a capacitor (eg 15 pF).
3	DEC	Power supply decoupling pin. Place capacitors as close as possible and connect directly to the ground plane (eg 10 nF & 10 pF).
4	GND	Ground pin. Ground pattern on the board should be as wide as possible to reduce ground impedance.
5	GND	Ground pin.
6	GND	Ground pin.
7	OUT	Divided frequency output pin. This pin should be coupled with a capacitor (eg 100 pF).
8	GND	Ground Pin.

Table 3. Absolute Maximum Ratings

Symbol	Parameter/Conditions	Min	Max	Units
VDD	Supply voltage		4.0	V
T _{ST}	Storage temperature range	-65	150	°C
T _{OP}	Operating temperature range	-40	85	°C
VESD	ESD voltage (Human Body Model)		250	V
P _{INMAX}	Maximum input power		10	dBm

Electrostatic Discharge (ESD) Precautions

When handling this UTSi device, observe the same precautions that you would use with other ESD-sensitive devices. Although this device contains circuitry to protect it from damage due to ESD, precautions should be taken to avoid exceeding the rating specified in Table 3.

Latch-Up Avoidance

Unlike conventional CMOS devices, UTSi CMOS devices are immune to latch-up.

Device Functional Considerations

The PE9302 takes an input signal frequency from between 1.5 GHz to 3.5 GHz and produces an output signal frequency one-fourth that of the supplied input. In order for the prescaler to work properly, several conditions need to be adhered to. It is crucial that pin 3 be supplied with a bypass capacitor to ground. In addition, the input and output signals (pins 2 & 7, respectively) need to be ac coupled via an external capacitor as shown in the test circuit below.

The ground pattern on the board should be made as wide as possible to minimize ground impedance.

Figure 3. Test Circuit Block Diagram

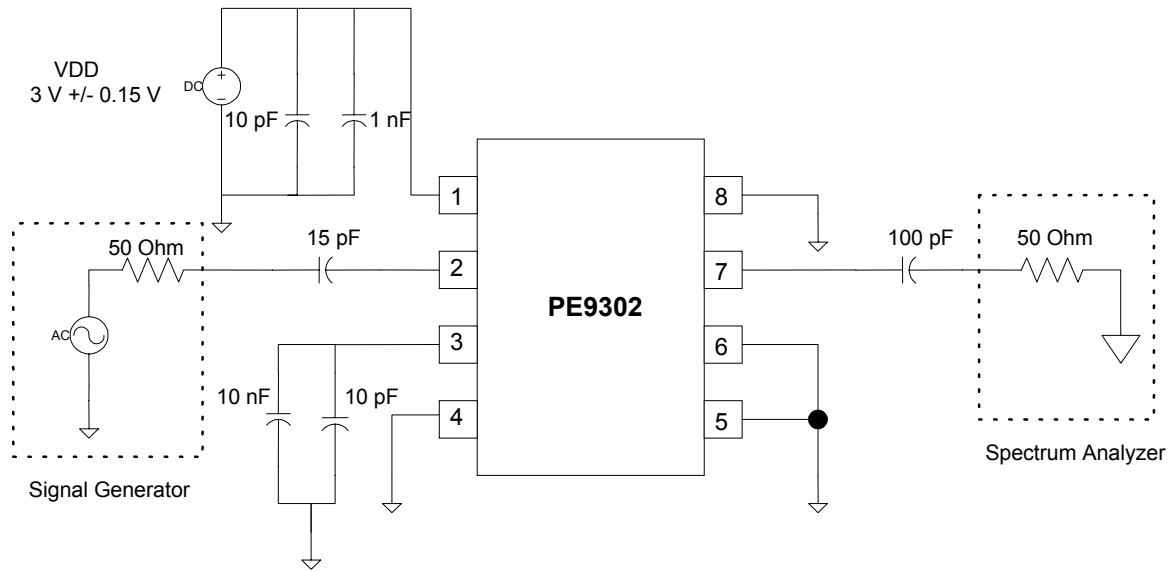
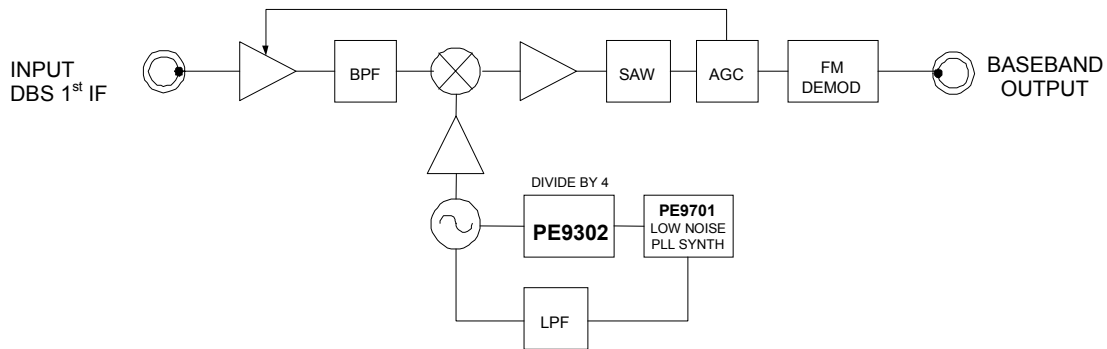

Figure 4. High Frequency System Application

The wideband frequency of operation of the PE9302 makes it an ideal part for use in a DBS down converter system.



Evaluation Board Description

The PE9302 evaluation board is depicted in Figure 5. The input is driven into the RF In port while the divided output is taken at Out 1. Both input and output contain footprints for AC coupling capacitors (C3 and C1 respectively). The power supply connection is provided near the top of the evaluation board, J2 Pin 1 as supply, J2 Pin 2 as ground. In addition C2, C5, and C10 are placeholders for power supply decoupling capacitors. Placeholders C4, C6, and C8 are needed for required bypass capacitors.

Note: C4 and C6 are located on the underside of the evaluation board.

Figure 5. PE9302 Evaluation Board

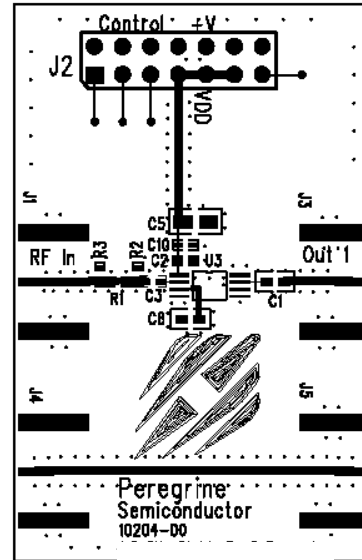

Evaluation Board Test Setup

The PE9302 can be tested on the evaluation board using the test setup shown in Figure 3 on page 3. In the test setup, it is essential that the power supply is properly decoupled and bypass capacitors are used for pin 3. In addition, the input and output need to be AC coupled.

Testing

The PE9302 Evaluation Board was measured prior to shipment using the setup depicted in Figure 3. Testing was performed at room temperature and $V_{DD} = 2.85$ V.

The input sensitivity plot for the PE9302 board is included with the evaluation kit.

Applications Support

If you have a problem with your evaluation kit or if you have applications questions call (858) 455-0660 and ask for applications support. You may also contact us by fax or e-mail:

Fax: (858) 455-0770

E-Mail: help@peregrine-semi.com

Table 4. Ordering Information

Order Code	Part Marking	Description	Package	Shipping Method
9302-01	9302	PE9302 Engineering Samples	8-lead FLAT PACK	Tray
9302-11	9302	PE9302 Production Units	8-lead FLAT PACK	Tray
9302-00	PE9302-EK	PE9302 Evaluation Kit	Evaluation Board	1 / Box

Sales Offices

United States

Peregrine Semiconductor Corp.

6175 Nancy Ridge Drive
San Diego, CA 92121
Tel 1-858-455-0660
Fax 1-858-455-0770

Europe

Peregrine Semiconductor Europe

Aix-En-Provence Office
Parc Club du Golf, bat 9
13856 Aix-En-Provence Cedex 3
France
Tel 33-0-4-4239-3360
Fax 33-0-4-4239-7227

Japan

Peregrine Semiconductor K.K.

The Imperial Tower, 15th floor
1-1-1 Uchisaiwaicho, Chiyoda-ku
Tokyo 100-0011 Japan
Tel: 03-3507-5755
Fax: 03-3507-5601

Australia

Peregrine Semiconductor Australia

8 Herb Elliot Ave.
Homebush, NSW 2140
Australia
Tel: 011-61-2-9763-4111
Fax: 011-61-2-9746-1501

For a list of representatives in your area, please refer to our Web site at: <http://www.peregrine-semi.com>

Data Sheet Identification

Advance Information

The product is in a formative or design stage. The data sheet contains design target specifications for product development. Specifications and features may change in any manner without notice.

Preliminary Specification

The data sheet contains preliminary data. Additional data may be added at a later date. Peregrine reserves the right to change specifications at any time without notice in order to supply the best possible product.

Product Specification

The data sheet contains final data. In the event Peregrine decides to change the specifications, Peregrine will notify customers of the intended changes by issuing a PCN (Product Change Notice).

The information in this data sheet is believed to be reliable. However, Peregrine assumes no liability for the use of this information. Use shall be entirely at the user's own risk.

No patent rights or licenses to any circuits described in this data sheet are implied or granted to any third party.

Peregrine's products are not designed or intended for use in devices or systems intended for surgical implant, or in other applications intended to support or sustain life, or in any application in which the failure of the Peregrine product could create a situation in which personal injury or death might occur. Peregrine assumes no liability for damages, including consequential or incidental damages, arising out of the use of its products in such applications.

Peregrine products are protected under one or more of the following U.S. patents: 6,090,648; 6,057,555; 5,973,382; 5,973,363; 5,930,638; 5,920,233; 5,895,957; 5,883,396; 5,864,162; 5,863,823; 5,861,336; 5,663,570; 5,610,790; 5,600,169; 5,596,205; 5,572,040; 5,492,857; 5,416,043. Other patents may be pending or applied for.

*UTSi, the Peregrine logotype, SEL Safe, and Peregrine Semiconductor Corp. are registered trademarks of Peregrine Semiconductor Corp. All PE product names and prefixes are trademarks of Peregrine Semiconductor Corp.
Copyright © 2001 Peregrine Semiconductor Corp. All rights reserved.*