

# NCS210, NCS211, NCS212, NCS213, NCS214, NCS215

## Current-Shunt Monitor, Voltage Output, Bi-Directional Zero-Drift

The NCS210, NCS211, NCS212, NCS213, NCS214, and NCS215 are voltage output current shunt monitors that can measure voltage across shunts at common-mode voltages from  $-0.3\text{ V}$  to  $26\text{ V}$ , independent of supply voltage. Six fixed gains are available:  $50\text{ V/V}$ ,  $75\text{ V/V}$ ,  $100\text{ V/V}$ ,  $200\text{ V/V}$ ,  $500\text{ V/V}$ , or  $1000\text{ V/V}$ . The low offset of the zero-drift architecture enables current sensing with maximum drops across the shunt as low as  $10\text{ mV}$  full-scale.

The devices can operate from a single  $+2.7\text{ V}$  to  $+26\text{ V}$  power supply, drawing a maximum of  $100\text{ }\mu\text{A}$  of supply current. All versions are specified over the extended operating temperature range ( $-40^{\circ}\text{C}$  to  $+125^{\circ}\text{C}$ ).

### Features

- Wide Common-Mode Input Range  $-0.3\text{ V}$  to  $26\text{ V}$
- Supply Voltage Range from  $2.7\text{ V}$  to  $26\text{ V}$
- Low Offset Voltage  $\pm 60\text{ }\mu\text{V}$  Max
- Low Offset Drift ( $0.1\text{ }\mu\text{V}/^{\circ}\text{C}$ )
- Low Gain Error (max 1%)
- Rail-to-rail Input and Output Capability
- Low Current Consumption (typ  $65\text{ }\mu\text{A}$ ,  $100\text{ }\mu\text{A}$  max)
- NCV Prefix for Automotive and Other Applications Requiring Unique Site Qualified and PPAP Capable
- These are Pb-free Devices

### Typical Applications

- Current Sensing (High-Side/Low-Side)
- Automotive
- Telecom
- Sensors



ON Semiconductor®

[www.onsemi.com](http://www.onsemi.com)



SC70-6  
SQ SUFFIX  
CASE 419B

### PIN CONNECTIONS

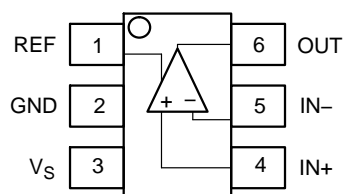

### MARKING DIAGRAM

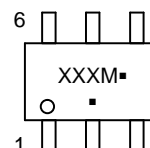

XXX = Specific Device Code (See page 4)

M = Date Code

▪ = Pb-Free Package

(Note: Microdot may be in either location)

Product	Gain	R3-R4	R1-R2
NCS213	50	20 k $\Omega$	1 M $\Omega$
NCS215	75	13.3 k $\Omega$	1 M $\Omega$
NCS214	100	10 k $\Omega$	1 M $\Omega$
NCS210	200	5 k $\Omega$	1 M $\Omega$
NCS211	500	2 k $\Omega$	1 M $\Omega$
NCS212	1000	1 k $\Omega$	1 M $\Omega$

$$V_{\text{OUT}} = (I_{\text{LOAD}} \times R_{\text{SHUNT}}) \text{GAIN} + V_{\text{REF}}$$

### ORDERING INFORMATION

See detailed ordering, marking and shipping information on page 4 of this data sheet.

# NCS210, NCS211, NCS212, NCS213, NCS214, NCS215

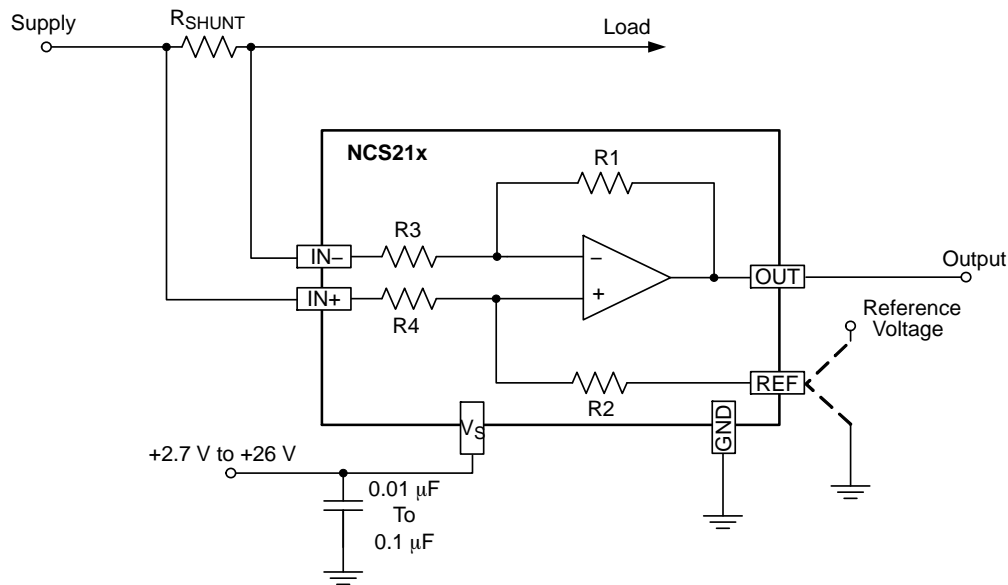

Figure 1. Application Schematic

Table 1. MAXIMUM RATINGS

Rating		Symbol	Value	Unit
Supply Voltage (Note 1)		$V_S$	+26	V
Analog Inputs	Differential ( $V_{IN+}$ )-(V <sub>IN-</sub> )	$V_{IN+}, V_{IN-}$	-26 to +26	V
	Common-Mode (Note 2)		GND-0.3 to +26	
REF Input		$V_{REF}$	GND-0.3 to ( $V_S$ ) +0.3	V
Output (Note 2)		$V_{OUT}$	GND-0.3 to ( $V_S$ ) +0.3	V
Input Current into Any Pin (Note 2)			5	mA
Maximum Junction Temperature		$T_{J(max)}$	+150	°C
Storage Temperature Range		TSTG	-65 to +150	°C
ESD Capability, Human Body Model (Note 3)		HBM	±3000	V
ESD Capability, Machine Model (Note 3)		MM	±100	V
Charged Device Model (Note 3)		CDM	±1000	V

Stresses exceeding those listed in the Maximum Ratings table may damage the device. If any of these limits are exceeded, device functionality should not be assumed, damage may occur and reliability may be affected.

1. Refer to ELECTRICAL CHARACTERISTICS, RECOMMENDED OPERATING RANGES and/or APPLICATION INFORMATION for safe operating parameters.
2. Input voltage at any pin may exceed the voltage shown if current at that pin is limited to 5 mA.
3. This device series incorporates ESD protection and is tested by the following methods  
 ESD Human Body Model tested per AEC-Q100-002 (EIA/JESD22-A114)  
 ESD Machine Model tested per AEC-Q100-003 (EIA/JESD22-A115)  
 ESD Charged Device Model tested per AEC-Q100-011.  
 Latchup Current Maximum Rating: 50 mA per JEDEC standard: JESD78

Table 2. THERMAL CHARACTERISTICS

Rating	Symbol	Value	Unit
Thermal Characteristics, SC70 (Note 4) Thermal Resistance, Junction-to-Air (Note 5)	$R_{\theta JA}$	250	°C/W

4. Refer to ELECTRICAL CHARACTERISTICS, RECOMMENDED OPERATING RANGES and/or APPLICATION INFORMATION for safe operating parameters.
5. Values based on copper area of 645 mm<sup>2</sup> (or 1 in<sup>2</sup>) of 1 oz copper thickness and FR4 PCB substrate.

# NCS210, NCS211, NCS212, NCS213, NCS214, NCS215

**Table 3. RECOMMENDED OPERATING RANGES**

Rating	Symbol	Min	Max	Unit
Supply Voltage	$V_S$	2.7	26	V
Ambient Temperature	$T_A$	-40	125	°C

Functional operation above the stresses listed in the Recommended Operating Ranges is not implied. Extended exposure to stresses beyond the Recommended Operating Ranges limits may affect device reliability.

**Table 4. ELECTRICAL CHARACTERISTICS**

**Boldface** limits apply over the specified temperature range,  $T_A = -40^{\circ}\text{C}$  to  $125^{\circ}\text{C}$ , guaranteed by characterization and/or design.

At  $T_A = +25^{\circ}\text{C}$ ,  $V_{\text{SENSE}} = V_{\text{IN}+} - V_{\text{IN}-}$ .

NCS210, NCS213, NCS214 and NCS215:  $V_S = +5\text{ V}$ ,  $V_{\text{IN}+} = 12\text{ V}$ , and  $V_{\text{REF}} = V_S/2$ , unless otherwise noted.

NCS211 and NCS212:  $V_S = +12\text{ V}$ ,  $V_{\text{IN}+} = 12\text{ V}$ , and  $V_{\text{REF}} = V_S/2$ , unless otherwise noted.

Parameter	Test Conditions	Symbol	Min	Typ	Max	Unit
<b>GAIN</b>						
NCS210 NCS211 NCS212 NCS213 NCS214 NCS215		G		200 500 1000 50 100 75		V/V
Gain Error	$V_{\text{SENSE}} = -5\text{ mV to }5\text{ mV}$	$G_e$		<b><math>\pm 0.2</math></b>	<b><math>\pm 1</math></b>	%
Gain Error vs. Temperature	$T_A = -10^{\circ}\text{C to }125^{\circ}\text{C}$			7	14	ppm/°C
Nonlinearity Error	$V_{\text{SENSE}} = -5\text{ mV to }5\text{ mV}$			$\pm 0.01$		%
Maximum Capacitive Load	No sustained oscillation			1		nF

**VOLTAGE OFFSET**

Offset Voltage (RTI Note 6)	NCS210, NCS211, NCS212, NCS214, NCS215	$V_{\text{SENSE}} = 0\text{ mV}$	$V_{\text{OS}}$		$\pm 0.55$	$\pm 60$	$\mu\text{V}$
	NCS213				$\pm 5$	$\pm 100$	$\mu\text{V}$
Offset Drift			$\delta V/\delta T$		<b>0.1</b>	<b>0.6</b>	$\mu\text{V}/^{\circ}\text{C}$

**INPUT**

Input Bias Current		$V_{\text{SENSE}} = 0\text{ mV}$	$I_{\text{IB}}$			60	$\mu\text{A}$
Common-Mode Input Voltage Range			$V_{\text{CM}}$	<b>-0.3</b>		<b>26</b>	V
Common-Mode Rejection Ratio	NCS210, NCS211, NCS212, NCS214, NCS215	<b><math>V_S = 5\text{ V}</math>, <math>V_{\text{IN}+} = 2\text{ V to }+26\text{ V}</math>, <math>V_{\text{SENSE}} = 0\text{ mV}</math></b>	CMRR	<b>103</b>	<b>115</b>		dB
		<b><math>V_S = 3.3\text{ V}</math>, <math>V_{\text{IN}+} = 3\text{ V to }+26\text{ V}</math>, <math>V_{\text{SENSE}} = 0\text{ mV}</math></b>		<b>103</b>	<b>115</b>		dB
		$V_S = 3.3\text{ V}$ , $V_{\text{IN}+} = 0\text{ V to }+26\text{ V}$ , $V_{\text{SENSE}} = 0\text{ mV}$ ( $T_A = -10^{\circ}\text{C to }85^{\circ}\text{C}$ )		103	120		dB
Common-Mode Rejection Ratio	NCS213	<b><math>V_S = 5\text{ V}</math>, <math>V_{\text{IN}+} = 2\text{ V to }+26\text{ V}</math>, <math>V_{\text{SENSE}} = 0\text{ mV}</math></b>	CMRR	<b>97</b>	<b>110</b>		dB
		<b><math>V_S = 3.3\text{ V}</math>, <math>V_{\text{IN}+} = 3\text{ V to }+26\text{ V}</math>, <math>V_{\text{SENSE}} = 0\text{ mV}</math></b>		<b>97</b>	<b>110</b>		dB
		$V_S = 3.3\text{ V}$ , $V_{\text{IN}+} = 0\text{ V to }+26\text{ V}$ , $V_{\text{SENSE}} = 0\text{ mV}$ ( $T_A = -10^{\circ}\text{C to }85^{\circ}\text{C}$ )		97	115		dB

**OUTPUT**

Output Voltage Low	Referenced from GND $R_L = 10\text{ k}\Omega$ to Ground	$V_{\text{OL}}$		5	50	mV
Output Voltage High	Referenced from $V_S$ $R_L = 10\text{ k}\Omega$ to Ground	$V_{\text{OH}}$		0.05	0.2	V

# NCS210, NCS211, NCS212, NCS213, NCS214, NCS215

**Table 4. ELECTRICAL CHARACTERISTICS**

**Boldface** limits apply over the specified temperature range,  $T_A = -40^{\circ}\text{C}$  to  $125^{\circ}\text{C}$ , guaranteed by characterization and/or design.

At  $T_A = +25^{\circ}\text{C}$ ,  $V_{\text{SENSE}} = V_{\text{IN}+} - V_{\text{IN}-}$ .

NCS210, NCS213, NCS214 and NCS215:  $V_S = +5\text{ V}$ ,  $V_{\text{IN}+} = 12\text{ V}$ , and  $V_{\text{REF}} = V_S/2$ , unless otherwise noted.

NCS211 and NCS212:  $V_S = +12\text{ V}$ ,  $V_{\text{IN}+} = 12\text{ V}$ , and  $V_{\text{REF}} = V_S/2$ , unless otherwise noted.

Parameter	Test Conditions	Symbol	Min	Typ	Max	Unit
<b>DYNAMIC PERFORMANCE</b>						
Bandwidth ( $f_{-3\text{dB}}$ )	$C_{\text{LOAD}} = 10\text{ pF}$ , NCS210	BW		40		kHz
	$C_{\text{LOAD}} = 10\text{ pF}$ , NCS211			25		
	$C_{\text{LOAD}} = 10\text{ pF}$ , NCS212			10		
	$C_{\text{LOAD}} = 10\text{ pF}$ , NCS213			100		
	$C_{\text{LOAD}} = 10\text{ pF}$ , NCS214			60		
	$C_{\text{LOAD}} = 10\text{ pF}$ , NCS215			50		
Slew Rate		SR		0.4		V/ $\mu\text{s}$

**NOISE**

Spectral Density, 1 kHz (RTI Note 6)		$e_n$		35		nV/ $\sqrt{\text{Hz}}$
--------------------------------------	--	-------	--	----	--	------------------------

**POWER SUPPLY**

Operating Voltage Range	$V_{\text{SENSE}} = 0\text{ mV}$	$V_S$	<b>2.7</b>		<b>26</b>	V
Quiescent Current	$V_{\text{SENSE}} = 0\text{ mV}$	$I_{\text{DD}}$		65	100	$\mu\text{A}$
Quiescent Current over Temperature	$V_{\text{SENSE}} = 0\text{ mV}$				<b>115</b>	$\mu\text{A}$
Power Supply Rejection Ratio	$V_S = +2.7\text{ V}$ to $+26\text{ V}$ , $V_{\text{IN}+} = 18\text{ V}$ , $V_{\text{SENSE}} = 0\text{ mV}$	PSRR		$\pm 0.1$	$\pm 10$	$\mu\text{V/V}$

6. RTI = referenced-to-input.

**ORDERING INFORMATION**

Device	Gain	Marking	Package	Shipping †
NCS210SQT2G	200	AAP	SC70-6	3000 / Tape and Reel
NCS211SQT2G (In Development)**	500	AAM	SC70-6	3000 / Tape and Reel
NCS212SQT2G (In Development)**	1000	AAN	SC70-6	3000 / Tape and Reel
NCS213SQT2G (In Development)**	50	AAQ	SC70-6	3000 / Tape and Reel
NCS214SQT2G (In Development)**	100	AAR	SC70-6	3000 / Tape and Reel
NCS215SQT2G (In Development)**	75	AAS	SC70-6	3000 / Tape and Reel
NCV210SQT2G * (In Development)**	200	AAP	SC70-6	3000 / Tape and Reel
NCV211SQT2G * (In Development)**	500	AAM	SC70-6	3000 / Tape and Reel
NCV212SQT2G * (In Development)**	1000	AAN	SC70-6	3000 / Tape and Reel
NCV213SQT2G * (In Development)**	50	AAQ	SC70-6	3000 / Tape and Reel
NCV214SQT2G * (In Development)**	100	AAR	SC70-6	3000 / Tape and Reel
NCV215SQT2G * (In Development)**	75	AAS	SC70-6	3000 / Tape and Reel

†For information on tape and reel specifications, including part orientation and tape sizes, please refer to our Tape and Reel Packaging Specifications Brochure, BRD8011/D

\*NCV Prefix for Automotive and Other Applications Requiring Unique Site and Control Change Requirements; AEC-Q100 Qualified and PPAP Capable.

\*\* Contact local sales office for availability.

# NCS210, NCS211, NCS212, NCS213, NCS214, NCS215

## PACKAGE DIMENSIONS

SC-88/SC70-6/SOT-363  
CASE 419B-02  
ISSUE Y

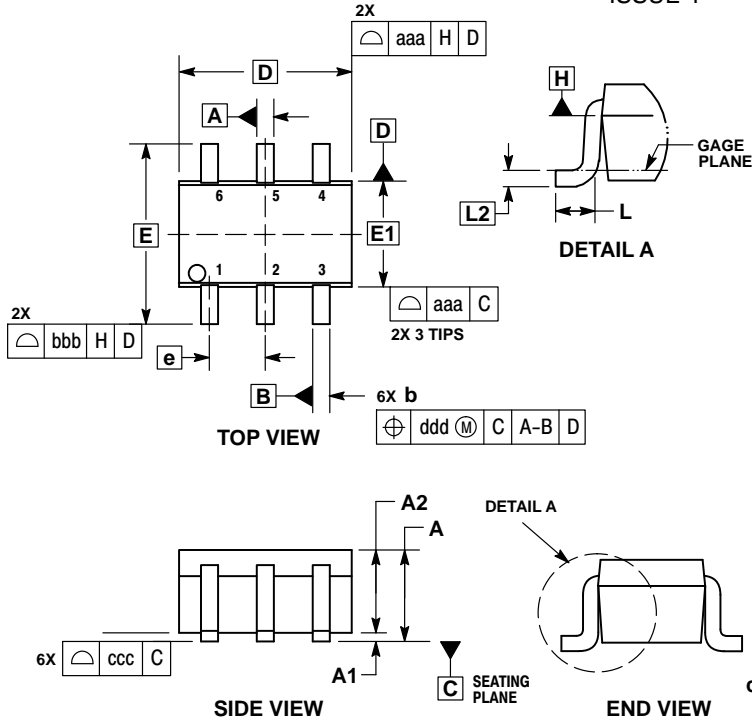

### NOTES:

1. DIMENSIONING AND TOLERANCING PER ASME Y14.5M, 1994.
2. CONTROLLING DIMENSION: MILLIMETERS.
3. DIMENSIONS D AND E1 DO NOT INCLUDE MOLD FLASH, PROTRUSIONS, OR GATE BURRS. MOLD FLASH, PROTRUSIONS, OR GATE BURRS SHALL NOT EXCEED 0.20 PER END.
4. DIMENSIONS D AND E1 AT THE OUTERMOST EXTREMES OF THE PLASTIC BODY AND DATUM H.
5. DATUMS A AND B ARE DETERMINED AT DATUM H.
6. DIMENSIONS b AND c APPLY TO THE FLAT SECTION OF THE LEAD BETWEEN 0.08 AND 0.15 FROM THE TIP.
7. DIMENSION b DOES NOT INCLUDE DAMBAR PROTRUSION. ALLOWABLE DAMBAR PROTRUSION SHALL BE 0.08 TOTAL IN EXCESS OF DIMENSION b AT MAXIMUM MATERIAL CONDITION. THE DAMBAR CANNOT BE LOCATED ON THE LOWER RADIUS OF THE FOOT.

DIM	MILLIMETERS			INCHES		
	MIN	NOM	MAX	MIN	NOM	MAX
A	---	---	1.10	---	---	0.043
A1	0.00	---	0.10	0.000	---	0.004
A2	0.70	0.90	1.00	0.027	0.035	0.039
b	0.15	0.20	0.25	0.006	0.008	0.010
C	0.08	0.15	0.22	0.003	0.006	0.009
D	1.80	2.00	2.20	0.070	0.078	0.086
E	2.00	2.10	2.20	0.078	0.082	0.086
E1	1.15	1.25	1.35	0.045	0.049	0.053
e	0.65 BSC			0.026 BSC		
L	0.26	0.36	0.46	0.010	0.014	0.018
L2	0.15 BSC			0.006 BSC		
aaa	0.15			0.006		
bbb	0.30			0.012		
ccc	0.10			0.004		
ddd	0.10			0.004		

### RECOMMENDED SOLDERING FOOTPRINT\*

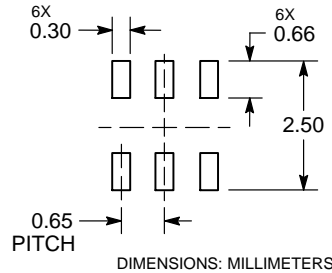

\*For additional information on our Pb-Free strategy and soldering details, please download the ON Semiconductor Soldering and Mounting Techniques Reference Manual, SOLDERRM/D.

ON Semiconductor and the  are registered trademarks of Semiconductor Components Industries, LLC (SCILLC) or its subsidiaries in the United States and/or other countries. SCILLC owns the rights to a number of patents, trademarks, copyrights, trade secrets, and other intellectual property. A listing of SCILLC's product/patent coverage may be accessed at [www.onsemi.com/site/pdf/Patent-Marking.pdf](http://www.onsemi.com/site/pdf/Patent-Marking.pdf). SCILLC reserves the right to make changes without further notice to any products herein. SCILLC makes no warranty, representation or guarantee regarding the suitability of its products for any particular purpose, nor does SCILLC assume any liability arising out of the application or use of any product or circuit, and specifically disclaims any and all liability, including without limitation special, consequential or incidental damages. "Typical" parameters which may be provided in SCILLC data sheets and/or specifications can and do vary in different applications and actual performance may vary over time. All operating parameters, including "Typicals" must be validated for each customer application by customer's technical experts. SCILLC does not convey any license under its patent rights nor the rights of others. SCILLC products are not designed, intended, or authorized for use as components in systems intended for surgical implant into the body, or other applications intended to support or sustain life, or for any other application in which the failure of the SCILLC product could create a situation where personal injury or death may occur. Should Buyer purchase or use SCILLC products for any such unintended or unauthorized application, Buyer shall indemnify and hold SCILLC and its officers, employees, subsidiaries, affiliates, and distributors harmless against all claims, costs, damages, and expenses, and reasonable attorney fees arising out of, directly or indirectly, any claim of personal injury or death associated with such unintended or unauthorized use, even if such claim alleges that SCILLC was negligent regarding the design or manufacture of the part. SCILLC is an Equal Opportunity/Affirmative Action Employer. This literature is subject to all applicable copyright laws and is not for resale in any manner.

### PUBLICATION ORDERING INFORMATION

#### LITERATURE FULFILLMENT:

Literature Distribution Center for ON Semiconductor  
19521 E. 32nd Pkwy, Aurora, Colorado 80011 USA  
Phone: 303-675-2175 or 800-344-3860 Toll Free USA/Canada  
Fax: 303-675-2176 or 800-344-3867 Toll Free USA/Canada  
Email: [orderlit@onsemi.com](mailto:orderlit@onsemi.com)

N. American Technical Support: 800-282-9855 Toll Free  
USA/Canada  
Europe, Middle East and Africa Technical Support:  
Phone: 421 33 790 2910  
Japan Customer Focus Center  
Phone: 81-3-5817-1050

ON Semiconductor Website: [www.onsemi.com](http://www.onsemi.com)

Order Literature: <http://www.onsemi.com/orderlit>

For additional information, please contact your local Sales Representative