



LM2596

3A Step-Down Voltage Regulator

GENERAL DESCRIPTION

The LM2596 series of regulators are monolithic integrated circuits that provide all the active functions for a step-down (buck) switching regulator, capable of driving a 3A load with excellent line and load regulation. These devices are available in fixed output voltages of 3.3V, 5V, 12V, and an adjustable output version.

Requiring a minimum number of external components, these regulators are simple to use and include internal frequency compensation†, and a fixed-frequency oscillator.

The LM2596 series operates at a switching frequency of 150 kHz thus allowing smaller sized filter components than what would be needed with lower frequency switching regulators. Available in a standard 5-lead TO-220 package with several different lead bend options, and a 5-lead TO-263 surface mount package.

A standard series of inductors are available from several different manufacturers optimized for use with the LM2596 series. This feature greatly simplifies the design of switch-mode power supplies.

Other features include a guaranteed $\pm 4\%$ tolerance on output voltage under specified input voltage and output load conditions, and $\pm 15\%$ on the oscillator frequency. External shutdown is included, featuring typically 80 μ A stand-by current. Self protection features include a two stage frequency reducing current limit for the output switch and an over temperature shutdown for complete protection under fault conditions.

FEATURES

- 3.3V, 5V, 12V, and adjustable output versions
- Adjustable version output voltage range, 1.2V to 37V $\pm 4\%$ max over line and load conditions
- Available in TO-220 and TO-263 packages
- Guaranteed 3A output load current
- Input voltage range up to 40V
- Requires only 4 external components
- Excellent line and load regulation specifications
- 150 kHz fixed frequency internal oscillator
- TTL shutdown capability
- Low power standby mode, IQ typically 80 μ A
- High efficiency
- Uses readily available standard inductors
- Thermal shutdown and current limit protection

APPLICATIONS

- Simple high-efficiency step-down (buck) regulator
- On-card switching regulators
- Positive to negative converter

ORDERING INFORMATION

Output Voltage				Package Type
3.3	5.0	12	ADJ	
LM2596S-3.3	LM2596S-5.0	LM2596S-12	LM2596S-ADJ	TO-263
LM2596T-3.3	LM2596T-5.0	LM2596T-12	LM2596T-ADJ	TO-220

PIN CONNECTION

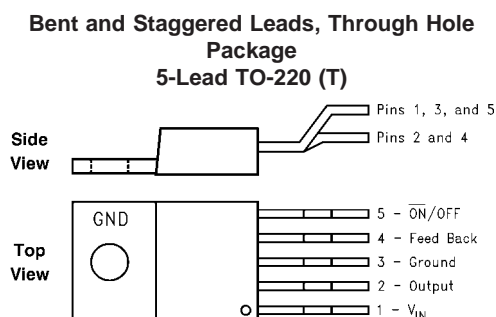

Order Number LM2596T-3.3, LM2596T-5.0,
LM2596T-12 or LM2596T-ADJ

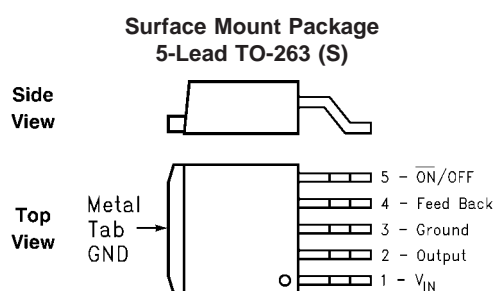

Order Number LM2596S-3.3, LM2596S-5.0,
LM2596S-12 or LM2596S-ADJ

TYPICAL APPLICATION (Fixed Output Voltage Versions)

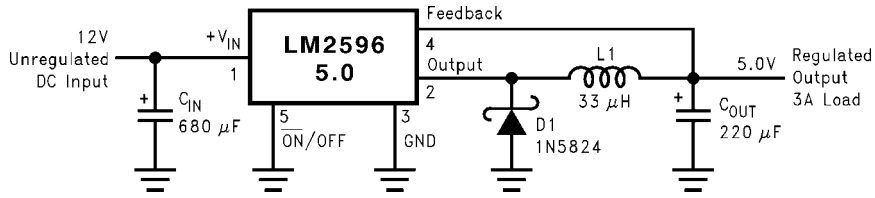

BLOCK DIAGRAM

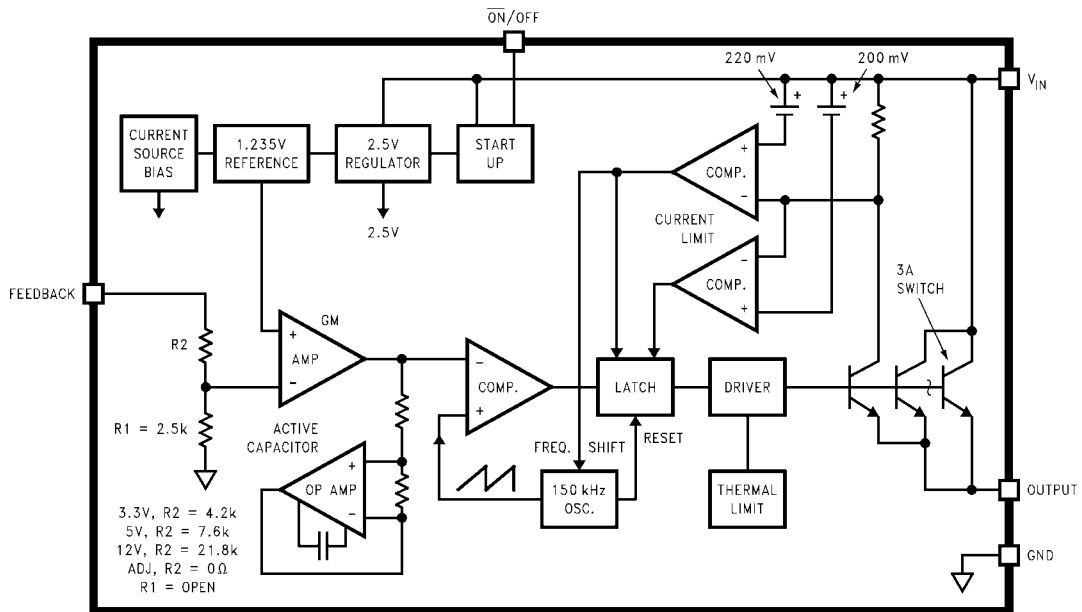

ABSOLUTE MAXIMUM RATINGS (Note 1)

Maximum Supply Voltage	45V	Human Body Model (Note 2)	2	kV
ON /OFF Pin Input Voltage	-0.3 ≤ V ≤ +25V	Lead Temperature		
Feedback Pin Voltage	-0.3 ≤ V ≤ +25V	S Package		
Output Voltage to Ground (Steady State)	-1V	Vapor Phase (60 sec.)		+215°C
Power Dissipation	Internally limited	Infrared (10 sec.)		+245°C
Storage Temperature Range	-65°C to +150°C	T Package (Soldering, 10 sec.)		+260°C
ESD Susceptibility		Maximum Junction Temperature		+150°C

OPERATING RATINGS

Temperature Range	-40°C ≤ T _J ≤ +125°C	Supply Voltage	4.5v to 40V
-------------------	---------------------------------	----------------	-------------

LM2596-3.3 ELECTRICAL CHARACTERISTICS

Specifications with standard type face are for T_J = 25°C, and those with **boldface type** apply over full Operating Temperature Range.

Symbol	Parameter	Conditions	LM2596-3.3		Units (Limits)
			Type (Note 3)	Limit (Note 4)	
SYSTEM PARAMETERS (Note 5) <i>Test Circuit Figure 1</i>					
V _{OUT}	Output Voltage	4.75V ≤ V _{IN} ≤ 40V, 0.2A ≤ I _{LOAD} ≤ 3A	3.3	3.168/ 3.135 3.432/ 3.465	V V(Min) V(Max)
η	Efficiency	V _{IN} = 12V, I _{LOAD} = 3A	73		%

LM2596-5.0 ELECTRICAL CHARACTERISTICS

Specifications with standard type face are for T_J = 25°C, and those with **boldface type** apply over full Operating Temperature Range.

Symbol	Parameter	Conditions	LM2596-5.0		Units (Limits)
			Type (Note 3)	Limit (Note 4)	
SYSTEM PARAMETERS (Note 5) <i>Test Circuit Figure 1</i>					
V _{OUT}	Output Voltage	7V ≤ V _{IN} ≤ 40V, 0.2A ≤ I _{LOAD} ≤ 3A Circuit of <i>Figure 2</i>	5.0	4.800/ 4.750 5.200/ 5.250	V V(Min) V(Max)
η	Efficiency	V _{IN} = 12V, I _{LOAD} = 3A	80		%

LM2596-12 ELECTRICAL CHARACTERISTICS

Specifications with standard type face are for T_J = 25°C, and those with **boldface type** apply over full Operating Temperature Range.

Symbol	Parameter	Conditions	LM2596-12		Units (Limits)
			Type (Note 3)	Limit (Note 4)	
SYSTEM PARAMETERS (Note 5) <i>Test Circuit Figure 1</i>					
V _{OUT}	Output Voltage	15V ≤ V _{IN} ≤ 40V, 0.2A ≤ I _{LOAD} ≤ 3A	12	11.52/ 11.40 12.48/ 12.60	V V(Min) V(Max)
η	Efficiency	V _{IN} = 25V, I _{LOAD} = 3A	90		%

LM2596-ADJ ELECTRICAL CHARACTERISTICS

Specifications with standard type face are for T_J = 25°C, and those with **boldface type** apply over full Operating Temperature Range.

Symbol	Parameter	Conditions	LM2596-ADJ		Units (Limits)
			Type (Note 3)	Limit (Note 4)	
SYSTEM PARAMETERS (Note 5) <i>Test Circuit Figure 1</i>					
V _{FB}	Feedback Voltage	4.5V ≤ V _{IN} ≤ 40V, 0.2A ≤ I _{LOAD} ≤ 3A V _{OUT} programmed for 3V, Circuit of <i>Figure 1</i>	1.230	1.193/ 1.180 1.267/ 1.280	V V(Min) V(Max)
η	Efficiency	V _{IN} = 12V, V _{OUT} = 5V, I _{LOAD} = 3A	73		%

ALL OUTPUT VOLTAGE VERSIONS ELECTRICAL CHARACTERISTICS

Specifications with standard type face are for $T_J = 25^\circ\text{C}$, and those with **boldface type** apply over full Operating Temperature Range. Unless otherwise specified, $V_{IN} = 12\text{V}$ for the 3.3V, 5V, and Adjustable version, $V_{IN} = 24\text{V}$ for the 12V version. $I_{LOAD} = 500\text{ mA}$.

Symbol	Parameter	Conditions	LM2596-XX		Units (Limits)
			Type (Note 3)	Limit (Note 4)	
DEVICE PARAMETERS					
I_b	Feedback Bias Current	Adjustable Version Only, $V_{FB} = 1.3\text{V}$	10	50/ 100	nA nA (max)
f_o	Oscillator Frequency	(Note 6)	150	127/ 110 173/ 173	kHz kHz(Min) kHz(Max)
V_{SAT}	Saturation Voltage	$I_{OUT} = 3\text{A}$ (Note 7,8)	1.16	1.4/ 1.5	V V(Max)
DC	Max Duty Cycle (ON) Min Duty Cycle (OFF)	(Note 8) (Note 9)	100 0		%
I_{CL}	Current Limit	Peak Current (Notes 7, 8)	4.5	3.6/ 3.4 6.9/ 7.5	A A(Min) A(Max)
I_L	Output Leakage Current	Output = 0V (Notes 7, 9)		50	μA (Max)
		Output = -1V (Notes 10)	2	30	mA mA(Max)
I_Q	Quiescent Current	(Note 9)	5	10	mA mA(Max)
I_{STBY}	Standby Quiescent Current	$\overline{\text{ON}}/\text{OFF}$ Pin = 5V (OFF) (Notes 10)	80	200/ 250	μA μA (Max)
θ_{JC} θ_{JA} θ_{JA} θ_{JA} θ_{JA}	Thermal Resistance	TO-220 or TO-263 Package, Junction to Case	2		$^\circ\text{C/W}$
		TO-220 Package, Junction to Ambient (Note 11)	50		
		TO-263 Package, Junction to Ambient (Note 12)	50		
		TO-263 Package, Junction to Ambient (Note 13)	30		
		TO-263 Package, Junction to Ambient (Note 13)	20		
$\overline{\text{ON}}/\text{OFF}$ CONTROL Test Circuit Figure 1					
V_{IH} V_{IL}	$\overline{\text{ON}}/\text{OFF}$ Pin Logic Input Threshold Voltage	Low (Regulator ON) High (Regulator OFF)	1.3	0.6 2.0	V V(Max) V(Min)
I_{IH}	$\overline{\text{ON}}/\text{OFF}$ Pin Input Current	$V_{LOGIC} = 2.5\text{V}$ (Regulator OFF)	5	15	μA μA (Max)
I_{IL}		$V_{LOGIC} = 0.5\text{V}$ (Regulator ON)	0.02	5	μA μA (Max)

Note 1: Absolute Maximum Ratings indicate limits beyond which damage to the device may occur. Operating Ratings indicate conditions for which the device is intended to be functional, but do not guarantee specific performance limits. For guaranteed specifications and test conditions, see the Electrical Characteristics.

Note 2: The human body model is a 100 pF capacitor discharged through a 1.5k resistor into each pin.

Note 3: Typical numbers are at 25°C and represent the most likely norm.

Note 4: All limits guaranteed at room temperature (standard type face) and at temperature extremes (bold type face). All room temperature limits are 100% production tested. All limits at temperature extremes are guaranteed via correlation using standard Statistical Quality Control (SQC) methods. All limits are used to calculate Average Outgoing Quality Level (AOQL).

Note 5: External components such as the catch diode, inductor, input and output capacitors, and voltage programming resistors can affect switching regulator system performance. When the LM2596 is used as shown in the Figure 1 test circuit, system performance will be as shown in system parameters section of Electrical Characteristics.

Note 6: The switching frequency is reduced when the second stage current limit is activated.

Note 7: No diode, inductor or capacitor connected to output pin.

Note 8: Feedback pin removed from output and connected to 0V to force the output transistor switch ON.

Note 9: Feedback pin removed from output and connected to 12V for the 3.3V, 5V, and the ADJ. version, and 15V for the 12V version, to force the output transistor switch OFF.

Note 10: $V_{IN} = 40\text{V}$.

Note 11: Junction to ambient thermal resistance (no external heat sink) for the TO-220 package mounted vertically, with the leads soldered to a printed circuit board with (1 oz.) copper area of approximately 1 in^2 .

Note 12: Junction to ambient thermal resistance with the TO-263 package tab soldered to a single printed circuit board with 0.5 in^2 of (1 oz.) copper area.

Note 13: Junction to ambient thermal resistance with the TO-263 package tab soldered to a single sided printed circuit board with 2.5 in^2 of (1 oz.) copper area.

Note 14: Junction to ambient thermal resistance with the TO-263 package tab soldered to a double sided printed circuit board with 3 in^2 of (1 oz.) copper area on the LM2596S side of the board, and approximately 16 in^2 of copper on the other side of the p-c board.

TYPICAL PERFORMANCE CHARACTERISTICS (Circuit of Figure 1)

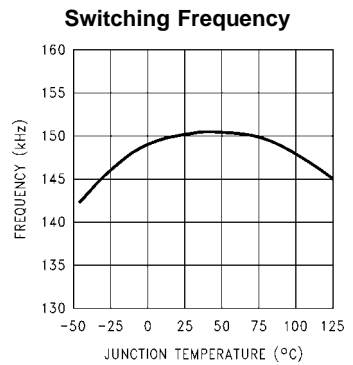
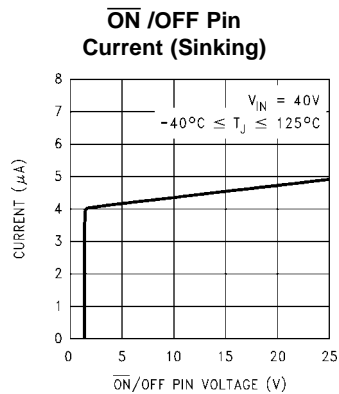
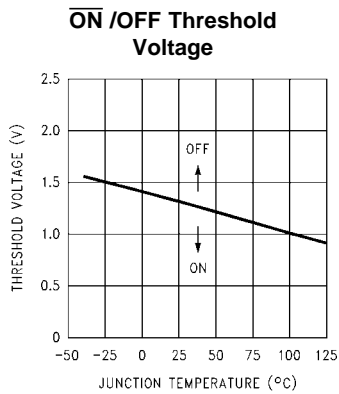
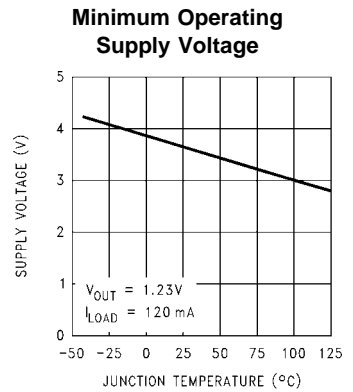
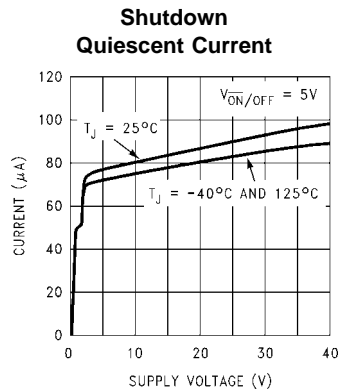
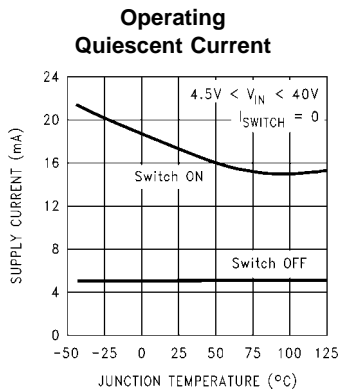
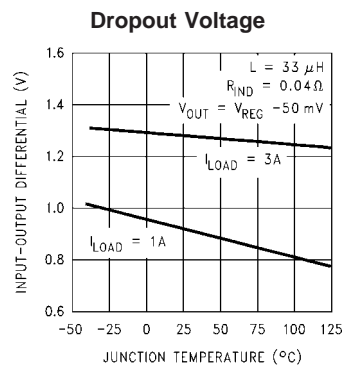
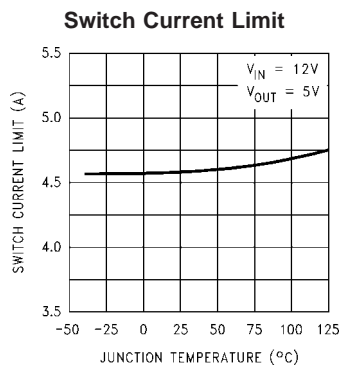
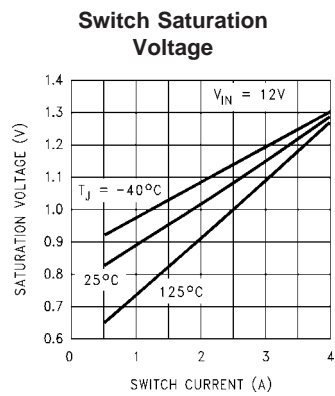
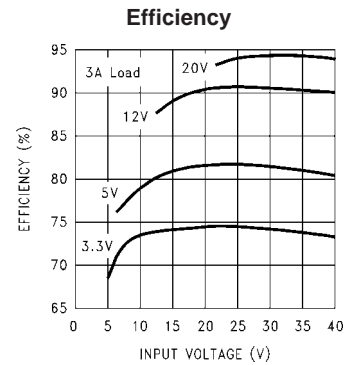
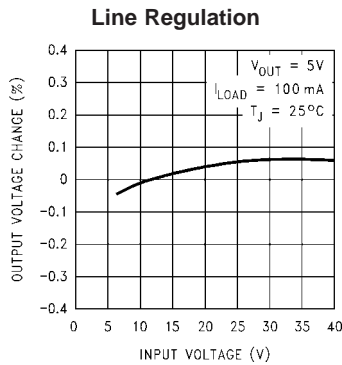
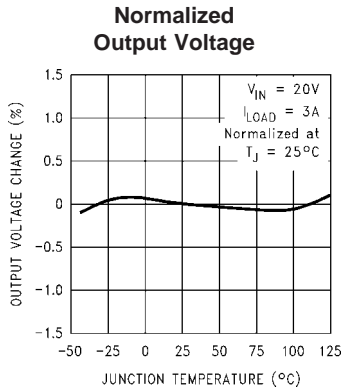

TYPICAL PERFORMANCE CHARACTERISTICS (Circuit of *Figure 1*) (Continued)

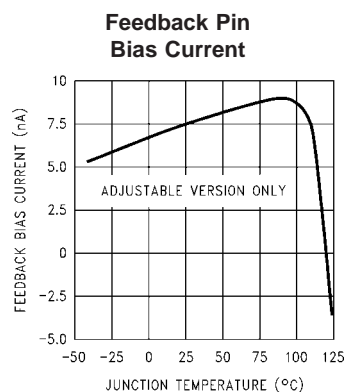

Continuous Mode Switching Waveforms

$V_{IN} = 20V, V_{OUT} = 5V, I_{LOAD} = 2A$
 $L = 32 \mu H, C_{OUT} = 220 \mu F, C_{OUT} ESR = 50 m\Omega$

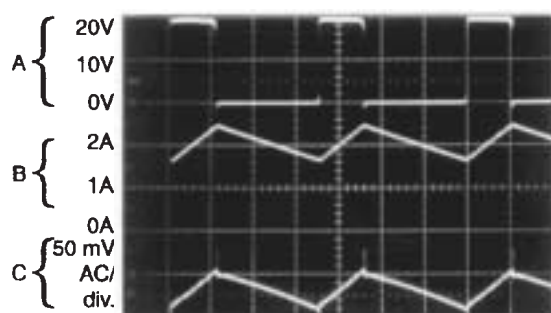

Horizontal Time Base: 2 μs /div.

- A: Output Pin Voltage, 10V/div.
- B: Inductor Current 1A/div.
- C: Output Ripple Voltage, 50 mV/div.

Discontinuous Mode Switching Waveforms

$V_{IN} = 20V, V_{OUT} = 5V, I_{LOAD} = 500 mA$
 $L = 10 \mu H, C_{OUT} = 330 \mu F, C_{OUT} ESR = 45 m\Omega$

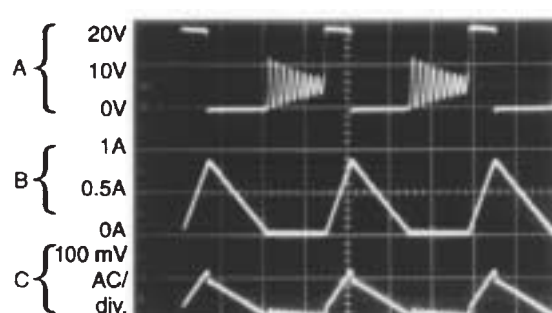

Horizontal Time Base: 2 μs /div.

- A: Output Pin Voltage, 10V/div.
- B: Inductor Current 0.5A/div.
- C: Output Ripple Voltage, 100 mV/div.

Load Transient Response for Continuous Mode

$V_{IN} = 20V, V_{OUT} = 5V, I_{LOAD} = 500 mA \text{ to } 2A$
 $L = 32 \mu H, C_{OUT} = 220 \mu F, C_{OUT} ESR = 50 m\Omega$

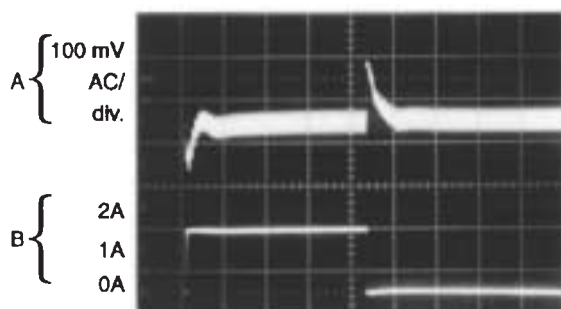

Horizontal Time Base: 100 μs /div.

- A: Output Voltage, 100 mV/div. (AC)
- B: 500 mA to 2A Load Pulse

Load Transient Response for Discontinuous Mode

$V_{IN} = 20V, V_{OUT} = 5V, I_{LOAD} = 500 mA \text{ to } 2A$
 $L = 10 \mu H, C_{OUT} = 330 \mu F, C_{OUT} ESR = 45 m\Omega$

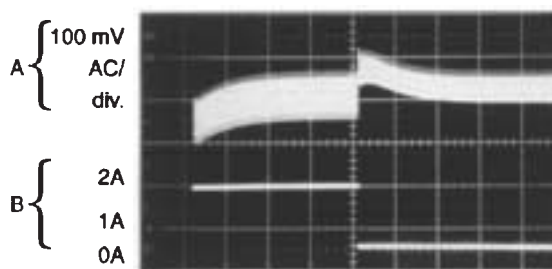

Horizontal Time Base: 200 μs /div.

- A: Output Voltage, 100 mV/div. (AC)
- B: 500 mA to 2A Load Pulse

TEST CIRCUIT AND LAYOUT GUIDELINES

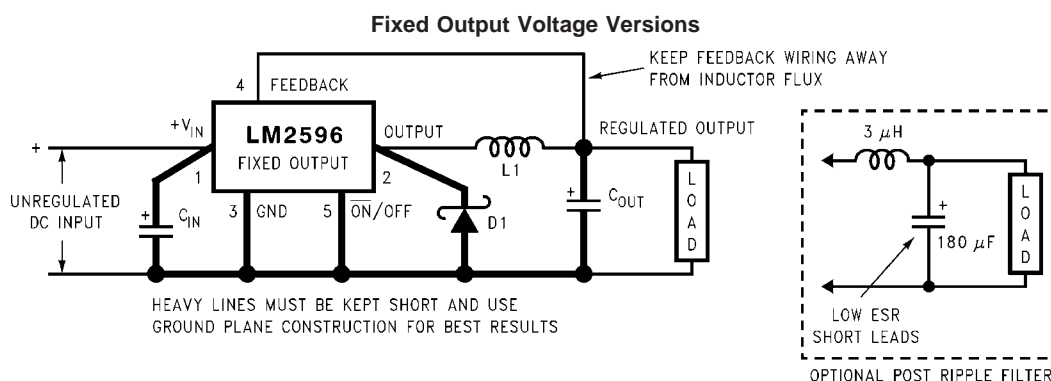

C_{IN} — 470 μF , 50V, Aluminum Electrolytic Nichicon "PL Series"

C_{OUT} — 220 μF , 25V Aluminum Electrolytic, Nichicon "PL Series"

D1 — 5A, 40V Schottky Rectifier, 1N5825

L1 — 68 μH , L38

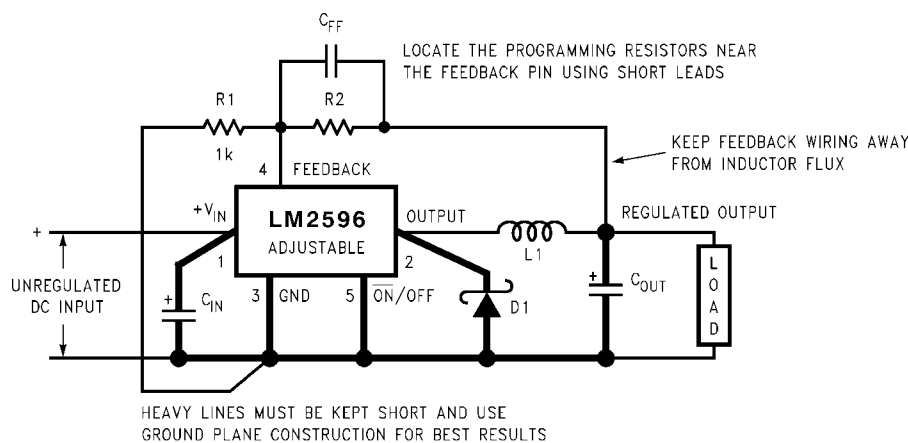
Adjustable Output Voltage Versions

$$V_{OUT} = V_{REF} \left(1 + \frac{R_2}{R_1} \right)$$

where $V_{REF} = 1.23\text{V}$

$$R_2 = R_1 \left(\frac{V_{OUT}}{V_{REF}} - 1 \right)$$

Select R_1 to be approximately 1 k Ω , use a 1% resistor for best stability.

C_{IN} — 470 μF , 50V, Aluminum Electrolytic Nichicon "PL Series"

C_{OUT} — 220 μF , 35V Aluminum Electrolytic, Nichicon "PL Series"

D1 — 5A, 40V Schottky Rectifier, 1N5825

L1 — 68 μH , L38

R1 — 1 k Ω , 1%

C_{FF} — See Application Information Section

FIGURE 1. Standard Test Circuits and Layout Guides

As in any switching regulator, layout is very important. Rapidly switching currents associated with wiring inductance can generate voltage transients which can cause problems. For minimal inductance and ground loops, the wires indicated by **heavy lines should be wide printed circuit traces and should be kept as short as possible**. For best results, external components should be located as close to the switching IC as possible using ground plane construction or single point grounding.

If **open core inductors are used**, special care must be taken as to the location and positioning of this type of inductor. Allowing the inductor flux to intersect sensitive feedback, IC groundpath and C_{OUT} wiring can cause problems.

When using the adjustable version, special care must be taken as to the location of the feedback resistors and the associated wiring. Physically locate both resistors near the IC, and route the wiring away from the inductor, especially an open core type of inductor.