

Data Sheet

Rev. 1.00 / April 2013

ZSPM9015

Ultra-Compact, High-Performance, High-Frequency DrMOS Device



Smart Power Management ICs



Power and Precision

ZSPM9015

Ultra-Compact, High-Performance, High-Frequency DrMOS Device

ZMDI[®]
The Analog Mixed Signal Company



Brief Description

The ZSPM9015 is ZMDI's next-generation, fully optimized, ultra-compact, integrated MOSFET plus driver power stage solution for high-current, high-frequency, synchronous buck DC-DC applications. The ZSPM9015 integrates a driver IC, two power MOSFETs, and a bootstrap Schottky diode into a thermally enhanced, ultra-compact 6x6mm package.

With an integrated approach, the complete switching power stage is optimized with regard to driver and MOSFET dynamic performance, system inductance, and power MOSFET $R_{DS(ON)}$. The ZSPM9015 uses innovative high-performance MOSFET technology, which dramatically reduces switch ringing, eliminating the need for a snubber circuit in most buck converter applications.

A driver IC with reduced dead times and propagation delays further enhances the performance. A thermal warning function indicates if a potential over-temperature situation ($>150^{\circ}\text{C}$) has occurred. An automatic thermal shutdown activates if an over-temperature condition ($>180^{\circ}\text{C}$) is detected. The ZSPM9015 also incorporates a Zero Current Detection Mode (ZCD) for improved light-load efficiency and provides a tri-state 3.3V and 5V PWM input for compatibility with a wide range of PWM controllers.

The ZSPM9015 DrMOS is compatible with ZMDI's ZSPM1000, a leading-edge configurable digital power-management system controller designed for non-isolated point-of-load (POL) supplies.

Features

- High-current handling: up to 35A
- PWM input capable of 3.3V and 5V
- Optimized for switching frequencies up to 1MHz
- Zero-current detection and under-voltage lockout (UVLO)
- Thermal shutdown and warning flag for over-temperature conditions
- Driver output disable function (DISB# pin)
- Integrated Schottky diode technology in the low-side MOSFET
- Integrated bootstrap Schottky diode
- Adaptive gate drive timing for shoot-through protection

Benefits

- Improved efficiency with zero current detection
- Clean switching waveforms with minimal ringing
- Based on the Intel® 4.0 DrMOS standard
- 72% space-saving compared to conventional discrete solutions
- High current handling
- Optimized for use with ZMDI's ZSPM1000 true digital PWM controller

Available Support

- ZSPM8015-KIT: Evaluation Kit for ZSPM9015

Physical Characteristics

- Operation temperature: 0°C to $+150^{\circ}\text{C}$
- V_{IN} : 4.5V to 25V (typical 12V)
- I_{OUT} : up to 35A
- Low-profile SMD package: 6mmx6mm QFN40
- ZMDI green packaging and RoHS compliant

Typical Application

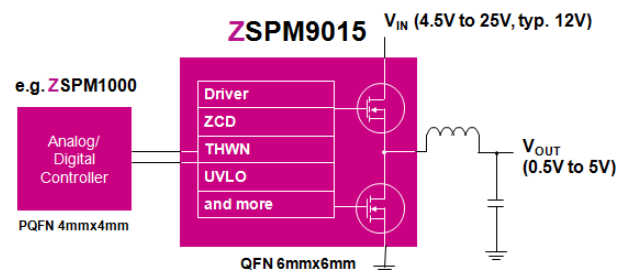

For more information, contact ZMDI via SPM@zmdi.com.

ZSPM9015

Ultra-Compact, High-Performance, High-Frequency DrMOS Device



The Analog Mixed Signal Company



ZSPM9015 Block Diagram

Typical Applications

- High-performance gaming motherboards
- Compact blade servers, Vcore and non-Vcore DC-DC converters
- Desktop computers, Vcore and Non-Vcore DC-DC converters
- Workstations
- High-current DC-DC point-of-load converters
- Networking and telecom microprocessor voltage regulators
- Small form-factor voltage regulator modules

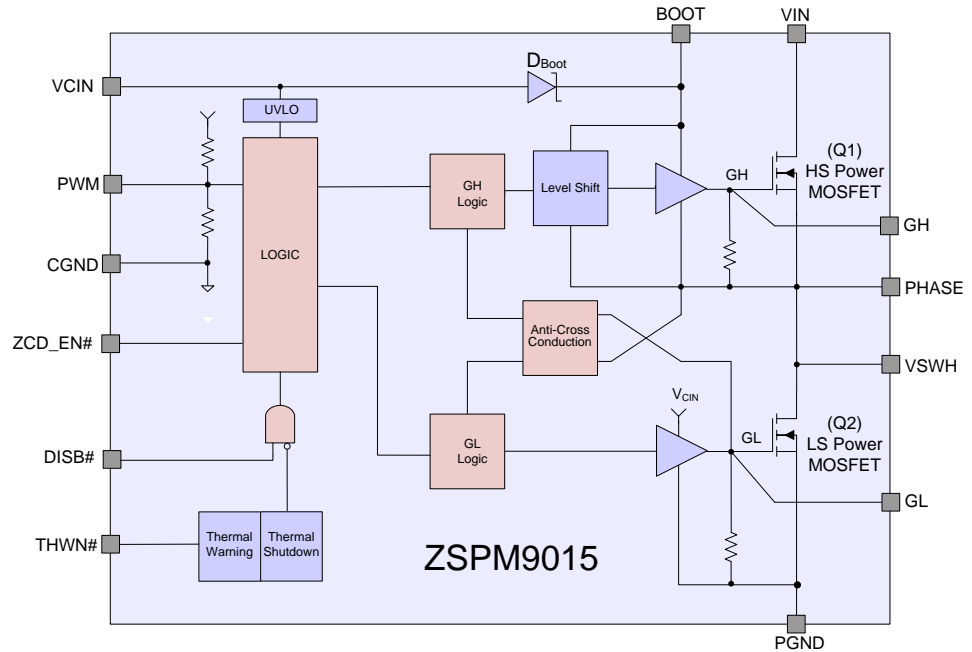

Ordering Information

| Product Sales Code | Description | Package |
|--------------------|--|---------|
| ZSPM9015ZI1R | ZSPM9015 RoHS-Compliant QFN40 – Junction temperature range: 0°C to 150°C | Reel |
| ZSPM8015-KIT | Evaluation Kit for ZSPM9015 | Kit |

Sales and Further Information

www.zmdi.com

SPM@zmdi.com

| | | | | |
|--|--|---|--|--|
| Zentrum Mikroelektronik Dresden AG Global Headquarters Grenzstrasse 28 01109 Dresden, Germany Central Office: Phone +49.351.8822.0 Fax +49.351.8822.600 | ZMD America, Inc. 1525 McCarthy Blvd., #212 Milpitas, CA 95035-7453 USA USA Phone +855.275.9634 Phone +408.883.6310 Fax +408.883.6358 | Zentrum Mikroelektronik Dresden AG, Japan Office 2nd Floor, Shinbashi Tokyu Bldg. 4-21-3, Shinbashi, Minato-ku Tokyo, 105-0004 Japan Phone +81.3.6895.7410 Fax +81.3.6895.7301 | ZMD FAR EAST, Ltd. 3F, No. 51, Sec. 2, Keelung Road 11052 Taipei Taiwan Phone +886.2.2377.8189 Fax +886.2.2377.8199 | Zentrum Mikroelektronik Dresden AG, Korea Office U-space 1 Building 11th Floor, Unit JA-1102 670 Sampyeong-dong Bundang-gu, Seongnam-si Gyeonggi-do, 463-400 Korea Phone +82.31.950.7679 Fax +82.504.841.3026 |
| European Technical Support Phone +49.351.8822.7.772 Fax +49.351.8822.87.772 | DISCLAIMER: This information applies to a product under development. Its characteristics and specifications are subject to change without notice. Zentrum Mikroelektronik Dresden AG (ZMD AG) assumes no obligation regarding future manufacture unless otherwise agreed to in writing. The information furnished hereby is believed to be true and accurate. However, under no circumstances shall ZMD AG be liable to any customer, licensee, or any other third party for any special, indirect, incidental, or consequential damages of any kind or nature whatsoever arising out of or in any way related to the furnishing, performance, or use of this technical data. ZMD AG hereby expressly disclaims any liability of ZMD AG to any customer, licensee or any other third party, and any such customer, licensee and any other third party hereby waives any liability of ZMD AG for any damages in connection with or arising out of the furnishing, performance or use of this technical data, whether based on contract, warranty, tort (including negligence), strict liability, or otherwise. | | | |
| European Sales (Stuttgart) Phone +49.711.674517.55 Fax +49.711.674517.87955 | | | | |



Contents

| | | |
|------|---|----|
| 1 | IC Characteristics | 6 |
| 1.1. | Absolute Maximum Ratings | 6 |
| 1.2. | Recommended Operating Conditions | 7 |
| 1.3. | Electrical Parameters | 7 |
| 1.4. | Typical Performance Characteristics | 9 |
| 2 | Functional Description | 11 |
| 2.1. | VCIN and Disable (DISB#) | 11 |
| 2.2. | Thermal Warning Flag (THWN#) and Thermal Shutdown | 12 |
| 2.3. | Tri-state PWM Input | 13 |
| 2.4. | Adaptive Gate Drive Circuit | 13 |
| 2.5. | Zero Current Detection Mode (ZCD_EN#) | 14 |
| 3 | Application Design | 16 |
| 3.1. | Supply Capacitor Selection | 16 |
| 3.2. | Bootstrap Circuit | 16 |
| 3.3. | Power Loss and Efficiency Testing Procedures | 17 |
| 4 | Pin Configuration and Package | 18 |
| 4.1. | Available Packages | 18 |
| 4.2. | Pin Description | 19 |
| 4.3. | Package Dimensions | 20 |
| 5 | Circuit Board Layout Considerations | 21 |
| 6 | Glossary | 22 |
| 7 | Ordering Information | 23 |
| 8 | Related Documents | 23 |
| 9 | Document Revision History | 23 |

List of Figures

| | | |
|-------------|--|----|
| Figure 1.1 | Power Loss vs. Output Current | 9 |
| Figure 1.2 | Efficiency vs. Output Current | 9 |
| Figure 1.3 | Power Loss vs. Output Current | 9 |
| Figure 1.4 | Efficiency vs. Output Current | 9 |
| Figure 1.5 | Power Loss vs. Switching Frequency | 10 |
| Figure 1.6 | Power Loss vs. Input Voltage | 10 |
| Figure 1.7 | Power Loss vs. Control Input Voltage | 10 |
| Figure 1.8 | Power Loss vs. Output Voltage | 10 |
| Figure 1.9 | Control Input Current vs. Switching Frequency | 10 |
| Figure 1.10 | Control Input Current vs. Control Input Voltage | 10 |
| Figure 2.1 | Block Diagram and Typical Application Circuit with PWM Control | 11 |
| Figure 2.2 | Thermal Warning Flag (THWN#) Operation | 12 |
| Figure 2.3 | PWM and Tri-state Timing Diagram | 13 |
| Figure 2.4 | ZCD_EN# Timing Diagram | 15 |

ZSPM9015

Ultra-Compact, High-Performance, High-Frequency DrMOS Device



The Analog Mixed Signal Company



| | | |
|------------|---|----|
| Figure 3.1 | Power Loss Measurement Block Diagram | 16 |
| Figure 4.1 | Pin-out PQFN40 Package | 18 |
| Figure 4.2 | QFN40 Physical Dimensions and Recommended Footprint | 20 |
| Figure 5.1 | PCB Layout Example..... | 22 |

List of Tables

| | | |
|-----------|--|----|
| Table 2.1 | UVLO and Disable Logic | 12 |
| Table 2.2 | ZCD Mode Operation (ZCD_EN# = LOW) and Switch States | 14 |



1 IC Characteristics

1.1. Absolute Maximum Ratings

The absolute maximum ratings are stress ratings only. The device might not function or be operable above the recommended operating conditions. Stresses exceeding the absolute maximum ratings might also damage the device. In addition, extended exposure to stresses above the recommended operating conditions might affect device reliability. ZMDI does not recommend designing to the “Absolute Maximum Ratings.”

| PARAMETER | SYMBOL | CONDITIONS | MIN | MAX | UNITS |
|--|-----------------|-------------------|-----------------|------|-------|
| Maximum Voltage – VCIN pin | | | -0.3 | 7.0 | V |
| Maximum Voltage – PWM, DISB#, THWN# and ZCD_EN# pins | | | -0.3 | 6.5 | V |
| Maximum Voltage – VIN pin | | | -0.3 | 30 | V |
| Maximum Voltage to BOOT pin – VSWH pin | | | -0.3 | 7.0 | V |
| Maximum Voltage to BOOT pin – PGND pin | | | -0.3 | 35.0 | V |
| Maximum Voltage to BOOT pin – PGND pin | | < 50ns | -0.3 | 40.0 | V |
| Maximum Sink Current – THWN# pin | $I_{THWN\#}$ | | | 30 | mA |
| Maximum Output Current | I_{OUT} | | | 35 | A |
| Thermal Resistance, High-Side MOSFET | θ_{JPCB} | | | 13 | °C/W |
| Thermal Resistance, Low-Side MOSFET | θ_{JPCB} | | | 5 | °C/W |
| Operating Junction Temperature | T_j | | 0 | +150 | °C |
| Storage Temperature Range | T_{STOR} | | -55 | +150 | °C |
| Electrostatic Discharge Protection | ESD | JEDEC JESD22-A114 | HBM Class 1B | | |
| Latch-Up Protection | LU | JEDEC JESD78 | Class 1 Level A | | |
| Moisture Sensitivity Level | MSL | | 3 | | |

ZSPM9015

Ultra-Compact, High-Performance, High-Frequency DrMOS Device



The Analog Mixed Signal Company



1.2. Recommended Operating Conditions

The “Recommended Operating Conditions” table defines the conditions for actual device operation. Recommended operating conditions are specified to ensure optimal performance to the datasheet specifications. ZMDI does not recommend exceeding them or designing to the “Absolute Maximum Ratings.”

| PARAMETER | SYMBOL | CONDITIONS | MIN | TYP | MAX | UNITS |
|--|-----------|------------|-----|------|-----|-------|
| Control Input Voltage | V_{CIN} | | 4.5 | 5.0 | 5.5 | V |
| Input Supply Voltage ¹⁾ | V_{IN} | | 4.5 | 12.0 | 25 | V |
| 1) Operating at high V_{IN} can create excessive AC overshoots on the VSWH-to-GND and BOOT-to-GND nodes during MOSFET switching transients. For reliable DrMOS operation, VSWH-to-GND and BOOT-to-GND must remain at or below the "Absolute Maximum Ratings" shown in the table above. Refer to sections 3 and 5 of this datasheet for additional information. | | | | | | |

1.3. Electrical Parameters

Note: Performance is guaranteed over the indicated operating temperature range by design and/or characterization tested at $T_J = T_A = 25^\circ\text{C}$. Low duty cycle pulse techniques are used during testing to maintain the junction temperature as close to ambient as possible.

Typical values are $V_{IN} = 12\text{V}$, $V_{CIN} = 5\text{V}$, ambient temperature $T_{AMB} = -10^\circ\text{C}$ to $+100^\circ\text{C}$ unless otherwise noted.

| PARAMETER | SYMBOL | CONDITIONS | MIN | TYP | MAX | UNITS |
|-------------------------------|----------------------|-------------------------------------|-------|------|-------|---------------|
| Supply Current | | | | | | |
| VCIN Current (Normal Mode) | | DISB# = 5V, PWM = OSC, FSW = 400kHz | | 14 | 20 | mA |
| VCIN Current (Disabled Mode) | | DISB# = GND | | 15 | 30 | μA |
| Under-Voltage Lock-Out | | | | | | |
| UVLO Threshold | UVLO | V_{CIN} rising | 3.8 | 4.35 | 4.5 | V |
| UVLO Hysteresis | UVLO _{Hyst} | | 0.150 | 0.2 | 0.250 | V |
| PWM Input | | | | | | |
| PWM Input Resistance | | | | 63 | | k Ω |
| PWM Input Bias Voltage | | | | 1.7 | | V |
| PWM High-Level Voltage | V_{IH_PWM} | | 2.65 | | | V |
| PWM Tri-state Level Voltage | V_{TRI_PWM} | | 1.4 | | 2.0 | V |
| PWM Low-Level Voltage | V_{IL_PWM} | | | | 0.7 | V |
| Tri-state Shutoff Time | $t_{d_HOLD-OFF}$ | | | 250 | | ns |

ZSPM9015

Ultra-Compact, High-Performance, High-Frequency DrMOS Device



The Analog Mixed Signal Company



| PARAMETER | SYMBOL | CONDITIONS | MIN | TYP | MAX | UNITS |
|-------------------------------|---------------------|---|-----|-----|-----|-------|
| DISB# Input | | | | | | |
| High-Level Input Voltage | $V_{IH_DISB\#}$ | | 2.0 | | | V |
| Low-Level Input Voltage | $V_{IL_DISB\#}$ | | | | 0.8 | V |
| Hysteresis | | | | 500 | | mV |
| Propagation Delay | t_{PD_DISB} | | | 20 | 40 | ns |
| Zero Current Detection | | | | | | |
| High-Level Input Voltage | $V_{IH_ZCD_EN\#}$ | | 2.0 | | | V |
| Low-Level Input Voltage | $V_{IL_ZCD_EN\#}$ | | | | 0.8 | V |
| ZCD Threshold | | | | -6 | | mV |
| ZCD Timer | t_{ZCD_DISB} | | | 250 | | ns |
| Thermal Warning Flag | | | | | | |
| Activation Temperature | T_{ACT} | | | 150 | | °C |
| Reset Temperature | T_{RST} | | | 135 | | °C |
| Thermal Shutdown | | | | | | |
| Activation Temperature | | | | 180 | | °C |
| Reset Temperature | T_{RST_SD} | | | 135 | | °C |
| Boot Diode | | | | | | |
| Forward-Voltage Drop | V_F | $V_{CIN} = 5V$, forward bias current = 2mA | 0.1 | 0.4 | 0.6 | V |

ZSPM9015

Ultra-Compact, High-Performance, High-Frequency DrMOS Device



The Analog Mixed Signal Company



1.4. Typical Performance Characteristics

Test conditions: $V_{IN}=12V$, $V_{OUT}=1.0V$, $V_{CIN}=5V$, $L_{OUT}=250nH$, $T_{AMB}=25^{\circ}C$, and natural convection cooling, unless otherwise specified.

Figure 1.1 Power Loss vs. Output Current

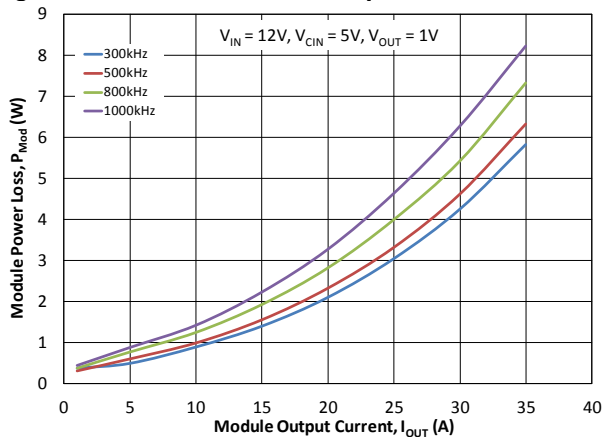

Figure 1.2 Efficiency vs. Output Current

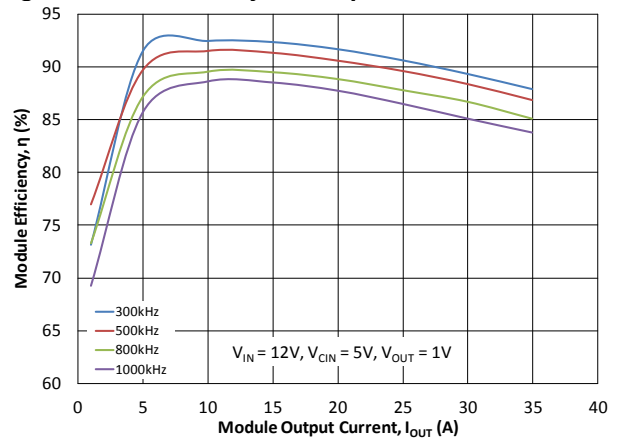

Figure 1.3 Power Loss vs. Output Current

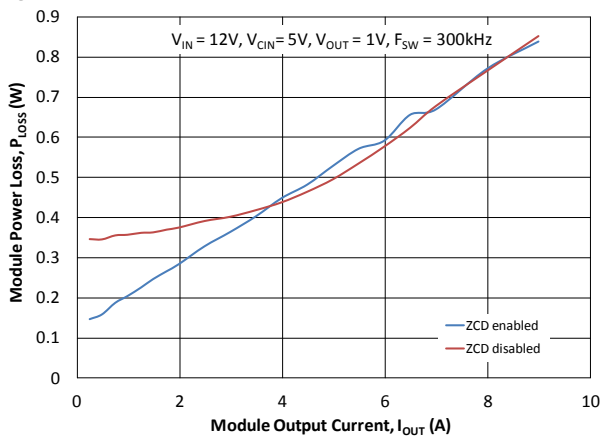
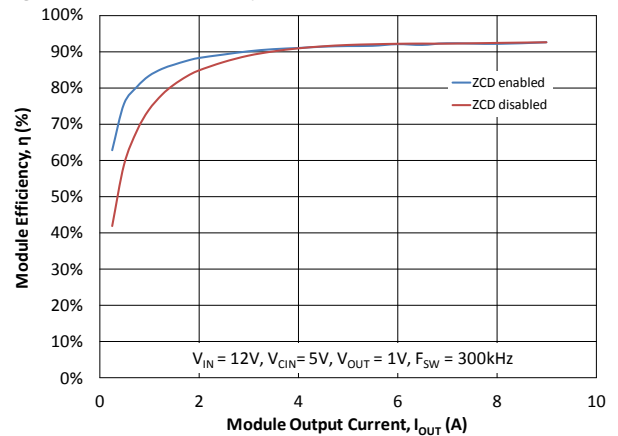

Figure 1.4 Efficiency vs. Output Current



ZSPM9015

Ultra-Compact, High-Performance, High-Frequency DrMOS Device



The Analog Mixed Signal Company



Figure 1.5 Power Loss vs. Switching Frequency

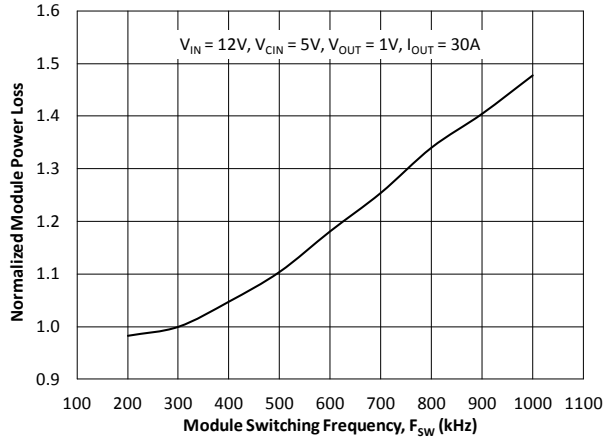

Figure 1.6 Power Loss vs. Input Voltage

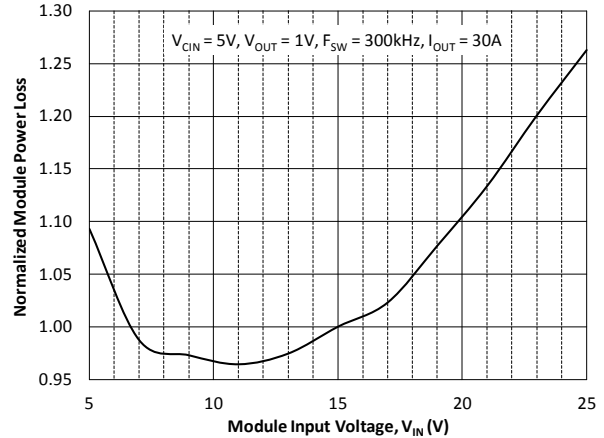

Figure 1.7 Power Loss vs. Control Input Voltage

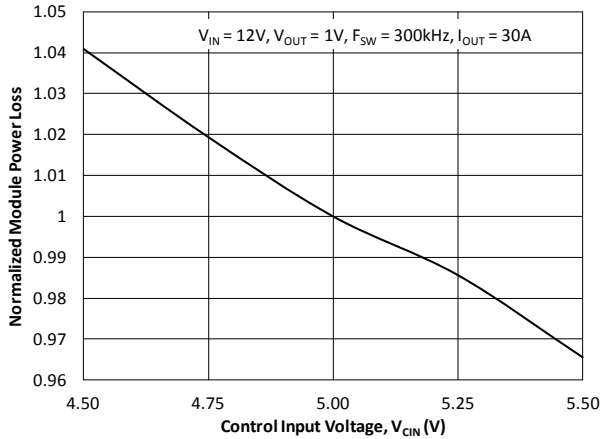

Figure 1.8 Power Loss vs. Output Voltage

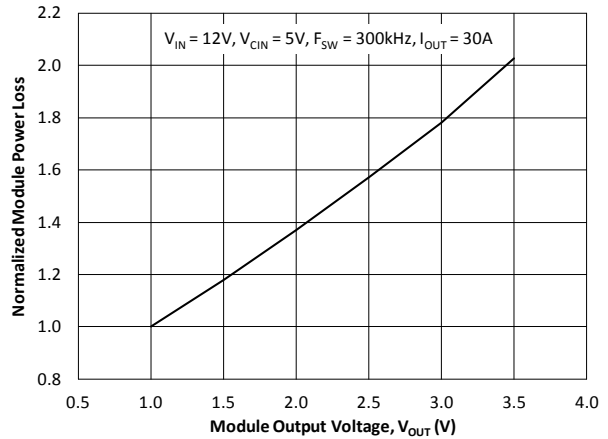

Figure 1.9 Control Input Current vs. Switching Frequency

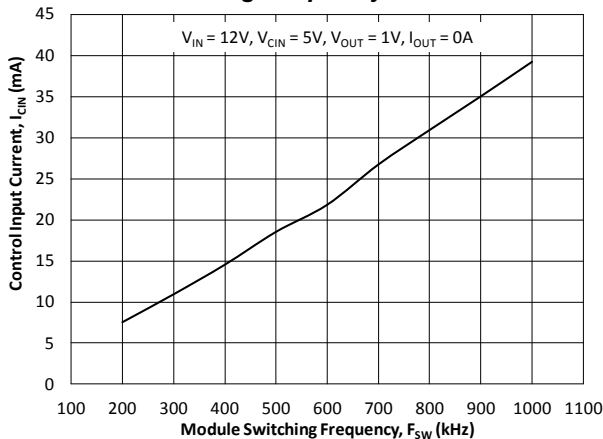
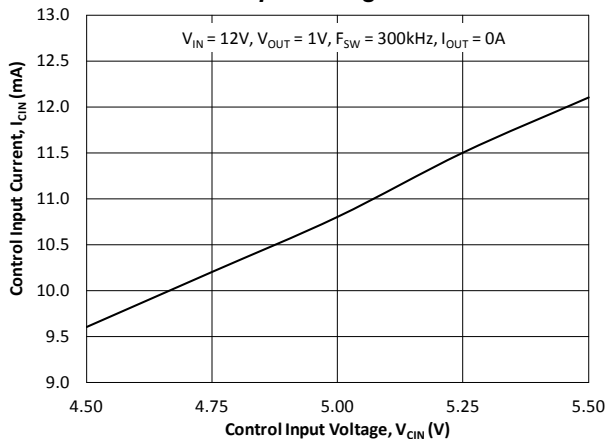

Figure 1.10 Control Input Current vs. Control Input Voltage





2 Functional Description

The ZSPM9015 is a driver-plus-MOSFET module optimized for the synchronous buck converter topology. A single PWM input signal is all that is required to properly drive the high-side and the low-side MOSFETs. It is capable of driving speeds up to 1MHz.

Figure 2.1 Block Diagram and Typical Application Circuit with PWM Control

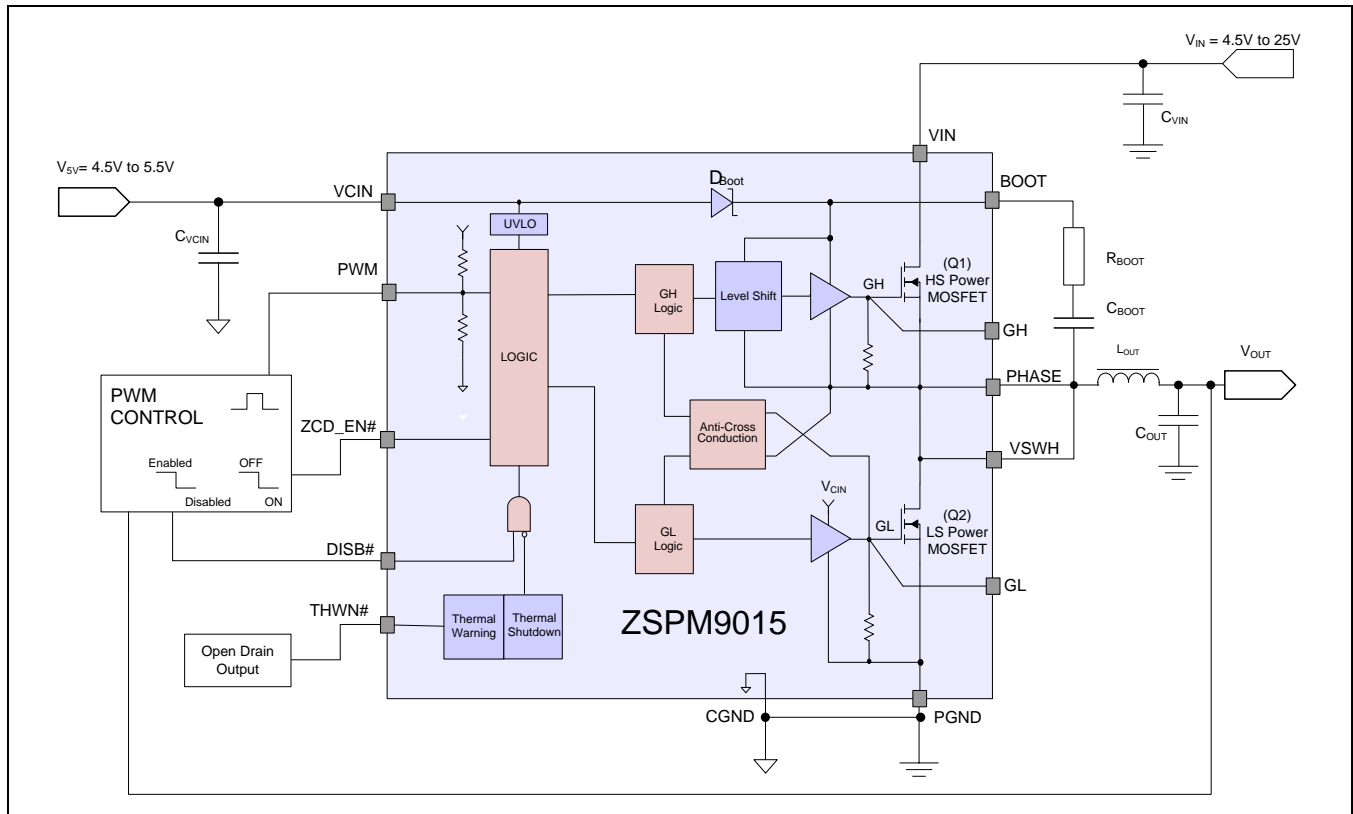

2.1. VCIN and Disable (DISB#)

The VCIN pin is monitored by the under-voltage lockout (UVLO) circuit. When V_{CIN} rises above $\sim 4.35V$, the driver is enabled. When V_{CIN} falls below $\sim 4.1V$, the driver is disabled (GH, GL = 0; see Table 2.1 and section 4.2).

The driver can also be disabled by pulling the DISB# pin LOW ($DISB\# < V_{IL_DISB\#}$; see section 1.3), which holds both GL and GH LOW regardless of the PWM input state. The driver can be enabled by raising the DISB# pin voltage HIGH ($DISB\# > V_{IH_DISB\#}$). It is advisable not to leave the DISB# floating.

ZSPM9015

Ultra-Compact, High-Performance, High-Frequency DrMOS Device



Table 2.1 UVLO and Disable Logic

| UVLO Circuit | DISB# | Driver State |
|--------------|-------|-----------------------|
| ON | X | Disabled (GH=0, GL=0) |
| OFF | Low | Disabled (GH=0, GL=0) |
| OFF | High | Enabled |
| OFF | Open | Disabled (GH=0, GL=0) |

ON = ULVO circuit is active and the driver output is disabled. The output will not respond to the PWM input under any condition.

Off = ULVO is non-active and the output operates normally. The output will respond to the PWM input provided the conditions are correct; e.g., not in thermal shutdown.

2.2. Thermal Warning Flag (THWN#) and Thermal Shutdown

The ZSPM9015 provides a thermal warning flag (THWN#) to indicate over-temperature conditions. The thermal warning flag uses an open-drain output that pulls to CGND when the activation temperature (150°C) is reached. The THWN# output returns to the high-impedance state once the temperature falls to the reset temperature (135°C). For use, the THWN# output requires a pull-up resistor, which can be connected to VCIN.

Figure 2.2 Thermal Warning Flag (THWN#) Operation

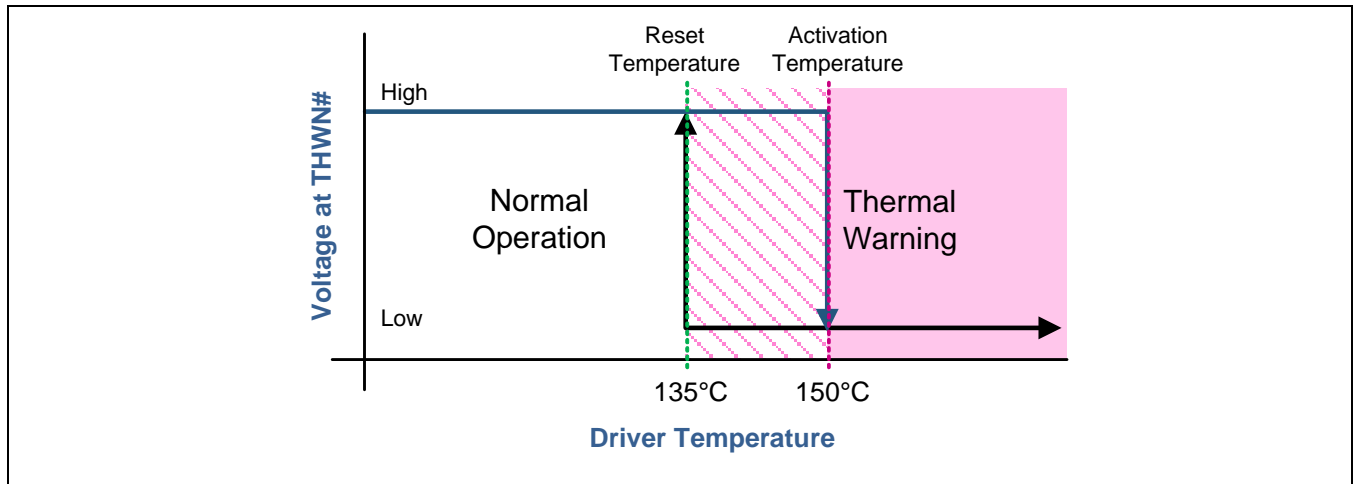

If the temperature exceeds 180°C then the part will enter thermal shutdown and turn off both MOSFETs. Upon the temperature falling below 155°C, the part will resume operation.



2.3. Tri-state PWM Input

The ZSPM9015 incorporates a tri-state PWM input gate drive design. The tri-state gate drive has both logic HIGH and LOW levels, with a tri-state shutdown voltage window. When the PWM input signal enters and remains within the tri-state voltage window for a defined hold-off time ($t_{D_HOLD-OFF}$), both GL and GH are pulled LOW. This feature enables the gate drive to shut down both the high and low side MOSFETs using only one control signal. For example, this can be used for phase shedding in multi-phase voltage regulators.

When exiting a valid tri-state condition, the ZSPM9015 follows the PWM input command. If the PWM input goes from tri-state to LOW, the low-side MOSFET is turned on. If the PWM input goes from tri-state to HIGH, the high-side MOSFET is turned on, as illustrated in Figure 2.3. The ZSPM9015's design allows for short propagation delays when exiting the tri-state window.

Figure 2.3 PWM and Tri-state Timing Diagram

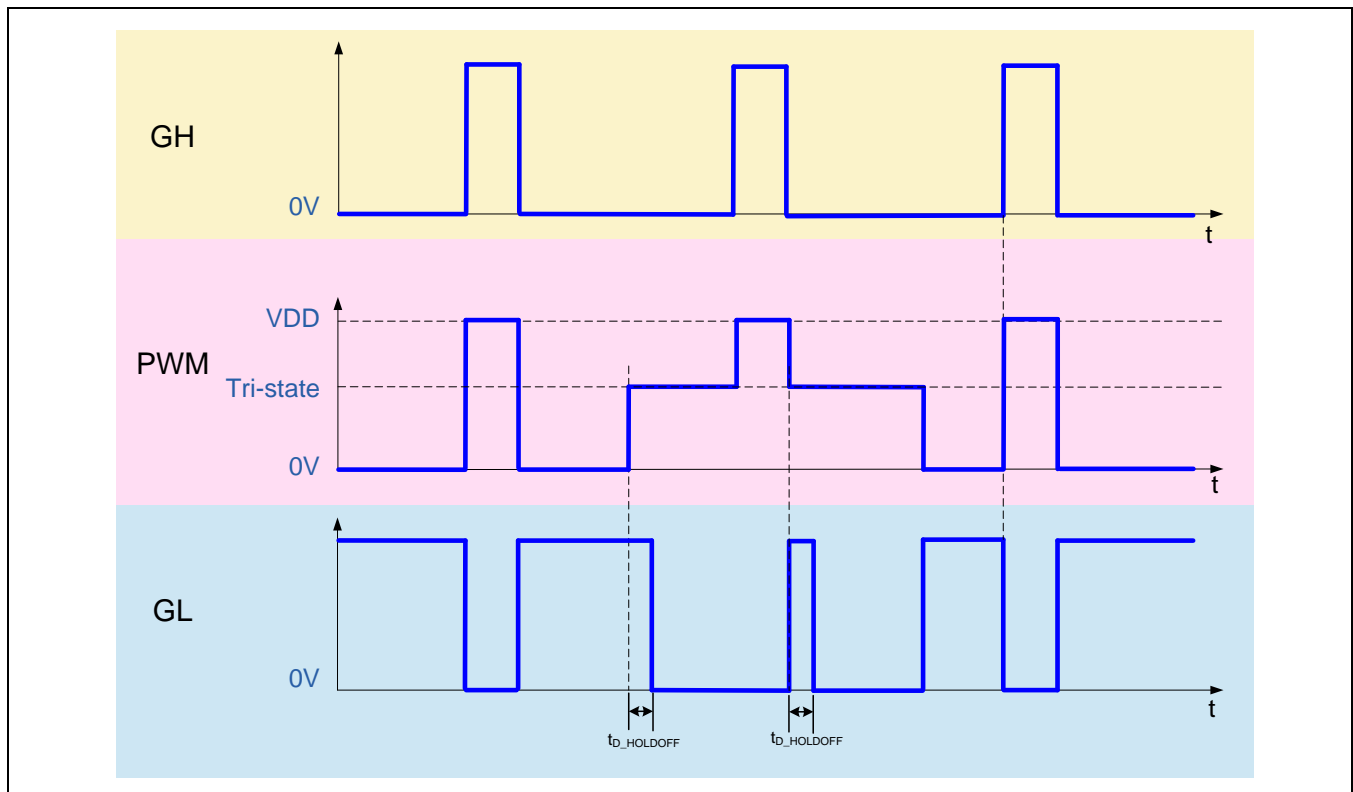

2.4. Adaptive Gate Drive Circuit

The low-side driver (GL) is designed to drive a ground-referenced low $R_{DS(ON)}$ N-channel MOSFET. The bias voltage for GL is internally connected between VCIN and PGND. The GL output follows the inverse of the PWM input with the exception that it is held LOW under any of the following conditions: a) the driver is disabled (DISB#=0V); b) the PWM signal is held within the tri-state window for longer than the tri-state hold-off time, $t_{D_HOLD-OFF}$; or c) specific circuit conditions that occur while in ZCD Mode (see section 2.5 for further details).

ZSPM9015

Ultra-Compact, High-Performance, High-Frequency DrMOS Device



The Analog Mixed Signal Company



The high-side driver (GH) is designed to drive a floating N-channel MOSFET. The bias voltage for the high-side driver is developed by a bootstrap supply circuit referenced to the switch node (V_{SWH}) pin. This circuit consists of an internal Schottky diode, an external bootstrap capacitor (C_{BOOT}), and the optional R_{BOOT} if used. During startup, the V_{SWH} pin is held at PGND, allowing C_{BOOT} (see section 3.2) to charge to V_{CIN} through the internal diode. When the PWM input goes HIGH, GH begins to charge the gate of Q1, the high-side MOSFET. During this transition, the charge is removed from C_{BOOT} and delivered to the gate of Q1. As Q1 turns on, V_{SWH} rises to V_{IN}, forcing the BOOT pin to V_{IN} + V_{BOOT}, which provides sufficient V_{GS} enhancement for Q1.

To complete the switching cycle, Q1 is turned off by pulling GH to V_{SWH}. C_{BOOT} is then recharged to V_{CIN} when V_{SWH} falls to PGND. The GH output follows the PWM input except that it is held LOW when either a) the driver is disabled (DISB#=0V) or b) the PWM signal is held within the tri-state window for longer than the tri-state hold-off time, t_{D_HOLDOFF}.

The ZSPM9015 design ensures minimum MOSFET dead time while eliminating potential shoot-through (cross-conduction) currents. It achieves this by monitoring the state of the MOSFETs and adjusts the gate drive adaptively to prevent simultaneous conduction.

When the PWM input goes HIGH, the gate of the low side MOSFET (GL pin) will go low after a propagation delay. The time it takes for the low side MOSFET to turn off is dependent on the gate charge on the low side MOSFET gate. The ZSPM9015 monitors the gate voltage of both MOSFETs to determine the conduction status of the MOSFETs. Once the low-side MOSFET is turned off, an internal timer will delay the turn on of the high-side MOSFET. Similarly, when the PWM input pin goes low, the converse occurs.

2.5. Zero Current Detection Mode (ZCD_EN#)

Zero Current Detection (ZCD) Mode allows higher converter efficiency under light-load conditions.

When the ZCD feature is disabled (ZCD_EN# is high), the ZSPM9015 will operate in the normal PWM Mode in which the synchronous buck converter works in Synchronous Mode.

If the ZCD_EN# is set low, then the ZSPM9015 will operate in the ZCD Mode, and in this mode, the ZSPM9015 can prevent discharging of the output capacitors as the filter inductor current attempts reverse current flow. If the PWM goes high, GH will go high after the non-overlap delay time. During this period, the ZCD timer is inactive and thus reset. If the PWM goes low, GL will go high after the non-overlap delay time and stay high for the duration of the ZCD timer (t_{ZCD_DISB}); see section 1.3. During this period ZCD operation is disabled. Once this timer has expired, V_{SWH} will be monitored for zero current detection and GL will go low if a zero-current condition is detected. The ZCD threshold (see section 1.3) on V_{SWH} to determine zero current undergoes an auto-calibration cycle every time DISB# is brought from LOW to HIGH. This auto-calibration cycle takes 25µs to complete.

Table 2.2 ZCD Mode Operation (ZCD_EN# = LOW) and Switch States

| PWM Input | ZCD Status | GH | GL |
|-----------|-------------------------------|------|------|
| High | ZCD timer is reset (inactive) | High | Low |
| Low | Positive inductor current | Low | High |
| Low | Zero inductor current | Low | Low |
| Tri-state | X | Low | Low |



Figure 2.4 ZCD_EN# Timing Diagram

See Figure 2.3 for the definitions of the timing parameters.

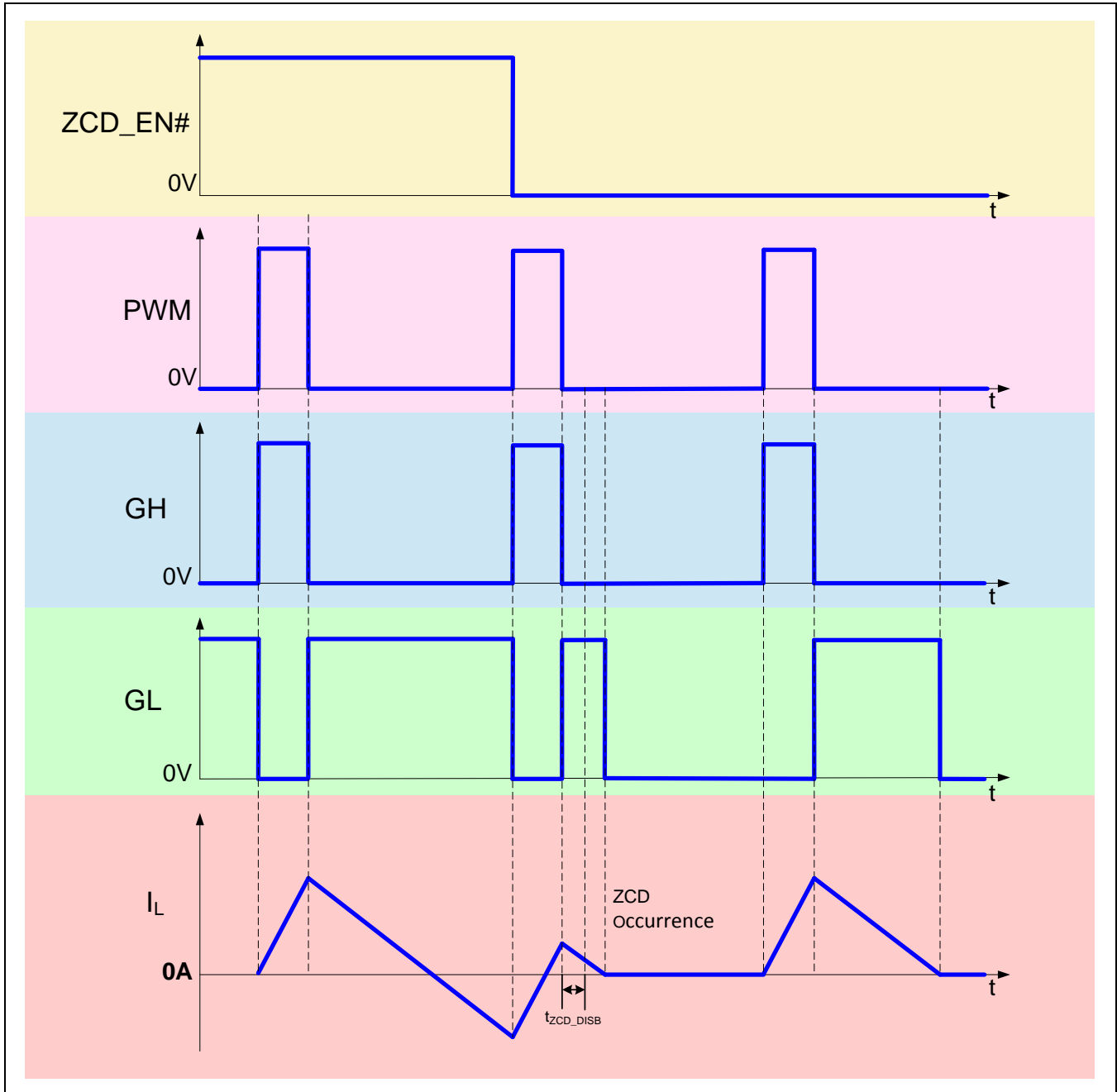



3 Application Design

3.1. Supply Capacitor Selection

For the supply input (VCIN), a local ceramic bypass capacitor (C_{CVIN}) is required to reduce noise and is used to supply the peak transient currents during gate drive switching action. Recommendation: use at a $1\mu\text{F}$ to $4.7\mu\text{F}$ capacitor with an X7R or X5R dielectric. Keep this capacitor close to the VCIN pin, and connect it to the CGND ground plane with vias.

3.2. Bootstrap Circuit

The bootstrap circuit uses a charge storage capacitor (C_{BOOT}), as shown in Figure 3.1. A bootstrap capacitance of 100nF using a X7R or X5R capacitor is typically adequate. A series bootstrap resistor might be needed for specific applications to improve switching noise immunity. The boot resistor might be required when operating with V_{IN} above 15V , and it is effective at controlling the high-side MOSFET turn-on slew rate and V_{SWH} overshoot. Typically, R_{BOOT} values from 0.5Ω to 3.0Ω are effective in reducing V_{SWH} overshoot.

Figure 3.1 Power Loss Measurement Block Diagram

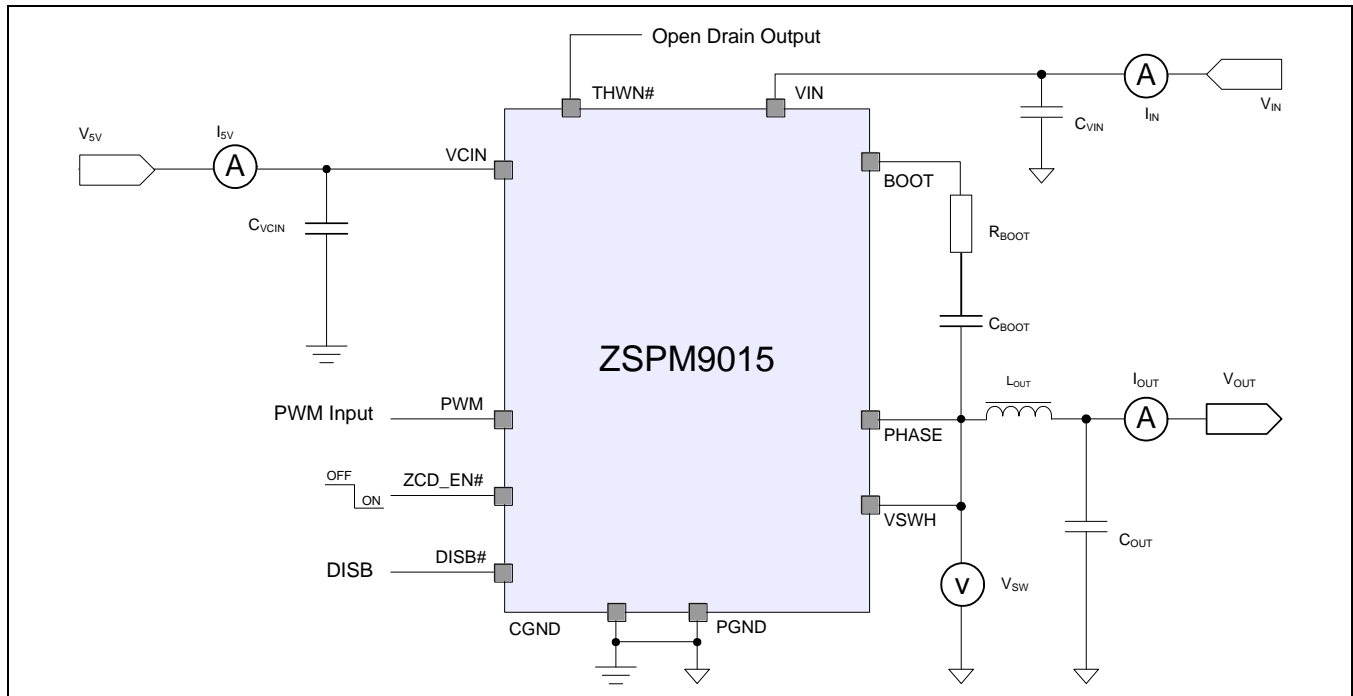



3.3. Power Loss and Efficiency Testing Procedures

The circuit in Figure 3.1 has been used to measure power losses in the following example. The efficiency has been calculated based on the equations (1) through (7).

Power loss calculations in Watts:

$$P_{IN} = (V_{IN} * I_{IN}) + (V_{5V} * I_{5V}) \quad (1)$$

$$P_{SW} = (V_{SW} * I_{OUT}) \quad (2)$$

$$P_{OUT} = (V_{OUT} * I_{OUT}) \quad (3)$$

$$P_{LOSS_MODULE} = (P_{IN} - P_{SW}) \quad (4)$$

$$P_{LOSS_BOARD} = (P_{IN} - P_{OUT}) \quad (5)$$

Efficiency calculations:

$$EFF_{MODULE} = \left(100 * \frac{P_{SW}}{P_{IN}} \right) \% \quad (6)$$

$$EFF_{BOARD} = \left(100 * \frac{P_{OUT}}{P_{IN}} \right) \% \quad (7)$$

ZSPM9015

Ultra-Compact, High-Performance, High-Frequency DrMOS Device



The Analog Mixed Signal Company



4 Pin Configuration and Package

4.1. Available Packages

The ZSPM9015 is available in a 40-lead clip-bond QFN package. The pin-out is shown in Figure 4.1. See Figure 4.2 for the mechanical drawing of the package.

Figure 4.1 Pin-out PQFN40 Package

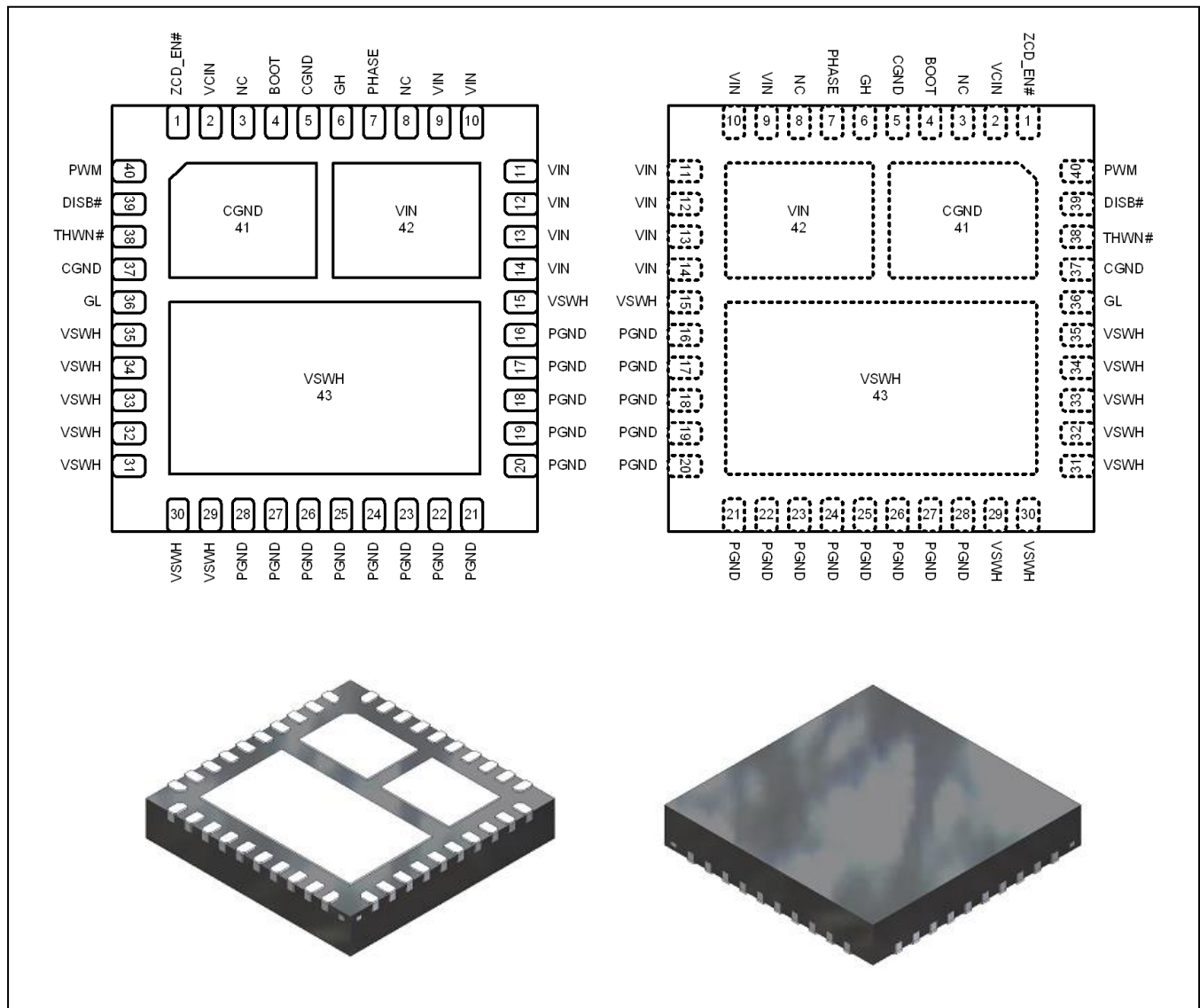

ZSPM9015

Ultra-Compact, High-Performance, High-Frequency DrMOS Device



The Analog Mixed Signal Company



4.2. Pin Description

| Pin | Name | Description |
|-------------------------|---------|---|
| 1 | ZCD_EN# | Enable Zero Current Detection Mode. Advisable not to leave floating. |
| 2 | VCIN | IC bias supply. A 1 μ F (minimum) ceramic capacitor is recommended from this pin to CGND. |
| 3 | NC | No connection. |
| 4 | BOOT | Bootstrap supply input. Provides voltage supply to the high-side MOSFET driver. Connect a bootstrap capacitor from this pin to PHASE. |
| 5, 37 & pad 41 | CGND | IC ground. Ground return for ZSPM9015. |
| 6 | GH | Gate high. For manufacturing test only. This pin must float: it must not be connected. |
| 7 | PHASE | Switch node pin for bootstrap capacitor routing; electrically shorted to VSWH pin. |
| 8 | NC | No connection. |
| 9 - 14 & pad 42 | VIN | Input power voltage (output stage supply voltage). |
| 15, 29 - 35 & pad 43 | VSWH | Switch node. Provides return for high-side bootstrapped driver and acts as a sense point for the adaptive shoot-through protection. |
| 16 – 28 | PGND | Power ground (output stage ground). Source pin of the low-side MOSFET. |
| 36 | GL | Gate low. For manufacturing test only. This pin must float. It must not be connected. |
| 38 | THWN# | Thermal warning flag. When temperature exceeds the trip limit, the output is pulled LOW. This pin has a maximum current capability of 30mA. |
| 39 | DISB# | Output disable. When LOW, this pin disables the power MOSFET switching (GH and GL are held LOW). Advisable not to leave floating. |
| 40 | PWM | PWM signal input. This pin accepts a tri-state 3.3V or 5V PWM signal from the controller. |

ZSPM9015

Ultra-Compact, High-Performance, High-Frequency DrMOS Device



The Analog Mixed Signal Company



4.3. Package Dimensions

Figure 4.2 QFN40 Physical Dimensions and Recommended Footprint

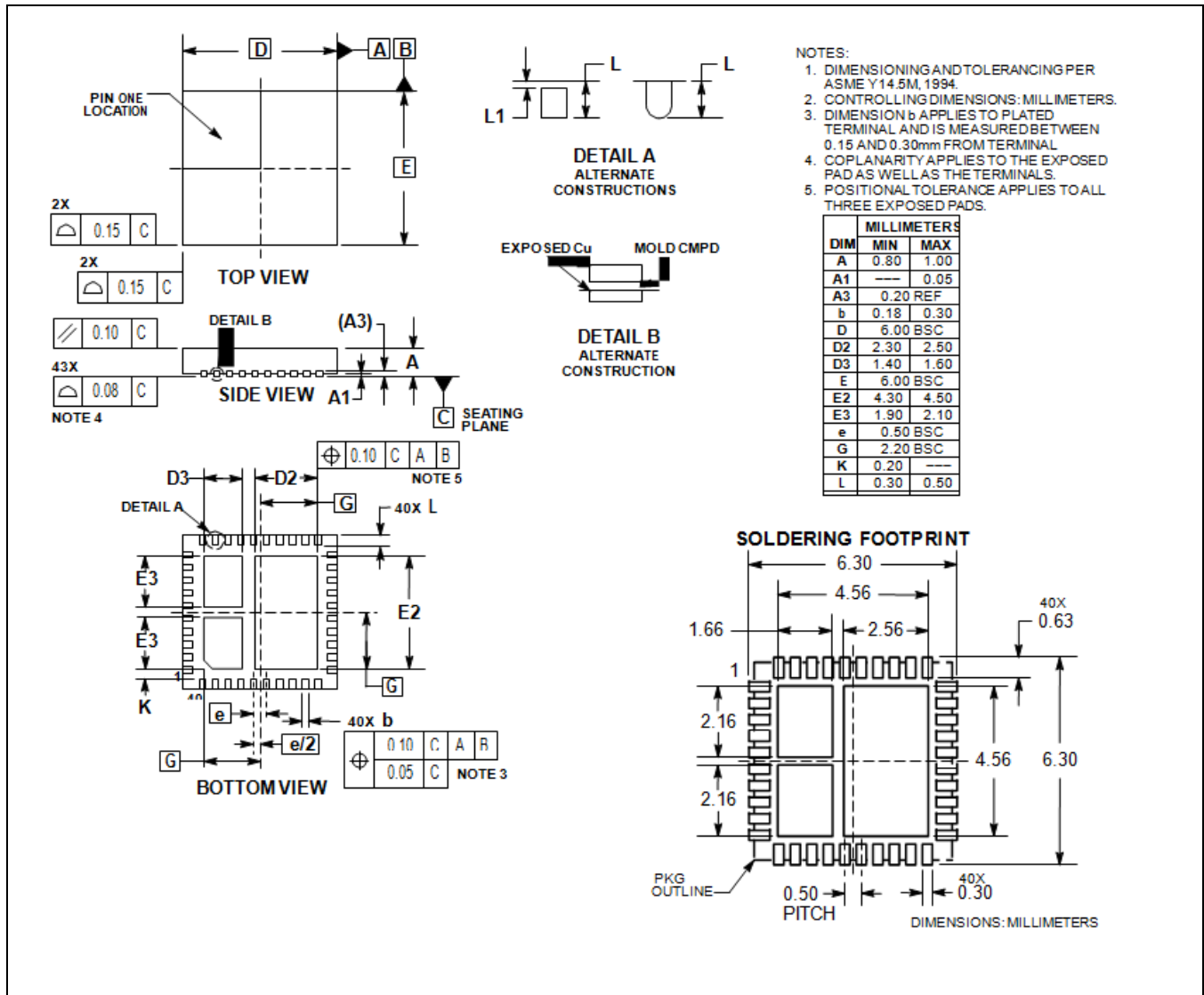



5 Circuit Board Layout Considerations

Figure 5.1 provides an example of a proper layout for the ZSPM9015 and critical components. All of the high-current paths, such as the V_{IN} , V_{SWH} , V_{OUT} , and GND copper traces, should be short and wide for low inductance and resistance. This technique achieves a more stable and evenly distributed current flow, along with enhanced heat radiation and system performance.

The following guidelines are recommendations for the printed circuit board (PCB) designer:

1. Input ceramic bypass capacitors must be placed close to the VIN and PGND pins. This helps reduce the high-current power loop inductance and the input current ripple induced by the power MOSFET switching operation.
2. The V_{SWH} copper trace serves two purposes. In addition to being the high-frequency current path from the DrMOS package to the output inductor, it also serves as a heat sink for the low-side MOSFET in the DrMOS package. The trace should be short and wide enough to present a low-impedance path for the high-frequency, high-current flow between the DrMOS and inductor to minimize losses and DrMOS temperature rise. Note that the VSWH node is a high-voltage and high-frequency switching node with a high noise potential. Care should be taken to minimize coupling to adjacent traces. Since this copper trace also acts as a heat sink for the lower MOSFET, the designer must balance using the largest area possible to improve DrMOS cooling with maintaining acceptable noise emission.
3. Locate the output inductor close to the ZSPM9015 to minimize the power loss due to the VSWH copper trace. Care should also be taken so that the inductor dissipation does not heat the DrMOS.
4. The power MOSFETs used in the output stage are effective for minimizing ringing due to fast switching. In most cases, no VSWH snubber is required. If a snubber is used, it should be placed close to the VSWH and PGND pins. The resistor and capacitor must be the proper size for the power dissipation.
5. VCIN and BOOT capacitors should be placed as close as possible the VCIN-to-CGND and BOOT-to-PHASE pin pairs to ensure clean and stable power. Routing width and length should be considered as well.
6. The layout should include a placeholder to insert a small-value series boot resistor (R_{BOOT}) between the boot capacitor (C_{BOOT}) and the ZSPM9015 BOOT pin. The boot-loop size, including R_{BOOT} and C_{BOOT} , should be as small as possible. The boot resistor may be required when operating with V_{IN} above 15V. The boot resistor is effective for controlling the high-side MOSFET turn-on slew rate and V_{SWH} overshoot. R_{BOOT} can improve the operating noise margin in synchronous buck designs that might have noise issues due to ground bounce or high positive and negative V_{SWH} ringing. However, inserting a boot resistance lowers the DrMOS efficiency. Efficiency versus noise trade-offs must be considered. R_{BOOT} values from 0.5Ω to 3.0Ω are typically effective in reducing V_{SWH} overshoot.
7. The VIN and PGND pins handle large current transients with frequency components greater than 100MHz. If possible, these pins should be connected directly to the VIN and board GND planes. Important: the use of thermal relief traces in series with these pins is discouraged since this adds inductance to the power path. Added inductance in series with the VIN or PGND pin degrades system noise immunity by increasing positive and negative V_{SWH} ringing.
8. Connect the CGND pad and PGND pins to the GND plane copper with multiple vias for stable grounding. Poor grounding can create a noise transient offset voltage level between CGND and PGND. This could lead to faulty operation of the gate driver and MOSFETs.

ZSPM9015

Ultra-Compact, High-Performance, High-Frequency DrMOS Device

ZMDI[®]

The Analog Mixed Signal Company



9. Ringing at the BOOT pin is most effectively controlled by close placement of the boot capacitor. Do not add an additional BOOT to PGND capacitor; this could lead to excess current flow through the BOOT diode.
10. It is advisable not to float the ZCD_EN# and DISB# pins.
11. Use multiple vias on each copper area to interconnect top, inner, and bottom layers to help distribute current flow and heat conduction. Vias should be relatively large and of reasonably low inductance. Critical high-frequency components, such as R_{BOOT} , C_{BOOT} , RC snubber, and bypass capacitors, should be located as close to the respective ZSPM9015 module pins as possible on the top layer of the PCB. If this is not feasible, they can be connected from the backside through a network of low-inductance vias.

Figure 5.1 PCB Layout Example

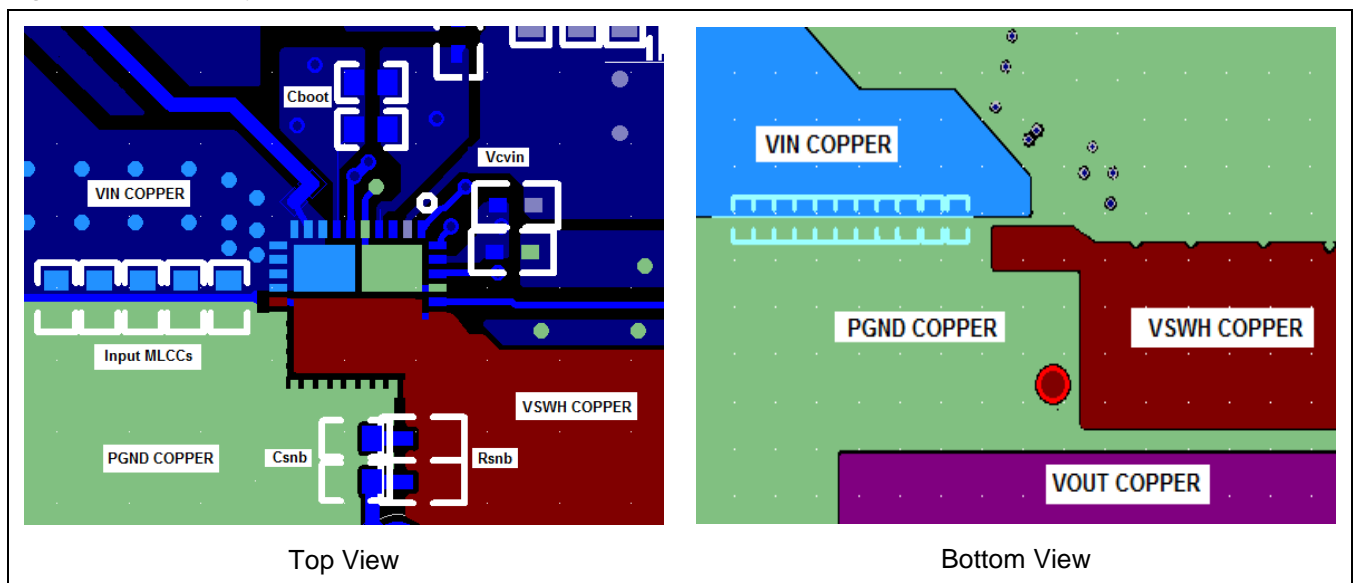

6 Glossary

| Term | Description |
|-------|-------------------------------|
| CCM | Continuous Conduction Mode |
| DCM | Discontinuous Conduction Mode |
| DISB | Driver Disable |
| HS | High Side |
| LS | Low Side |
| THWN# | Thermal Warning Flag |
| ZCD | Zero Current Detection |
| IL | Inductor Current |

ZSPM9015

Ultra-Compact, High-Performance, High-Frequency DrMOS Device



The Analog Mixed Signal Company



7 Ordering Information

| Product Sales Code | Description | Package |
|--------------------|--|---------|
| ZSPM9015ZI1R | ZSPM9015 RoHS-Compliant QFN40 – Junction temperature range: 0°C to 150°C | Reel |
| ZSPM8015-KIT | Evaluation Kit for ZSPM9015 | Kit |

8 Related Documents

| Document | File Name |
|---|-------------------------------|
| ZSPM8015-KIT Evaluation Kit Description | ZSPM8015_Eval_Kit_revX_xy.pdf |

Visit ZMDI's website www.zmdi.com or contact your nearest sales office for the latest version of these documents.

9 Document Revision History

| Revision | Date | Description |
|----------|----------------|---------------|
| 1.00 | April 26, 2013 | First release |

| Sales and Further Information | | www.zmdi.com | SPM@zmdi.com | |
|--|--|---|--|--|
| Zentrum Mikroelektronik Dresden AG Global Headquarters Grenzstrasse 28 01109 Dresden, Germany Central Office: Phone +49.351.8822.0 Fax +49.351.8822.600 | ZMD America, Inc. 1525 McCarthy Blvd., #212 Milpitas, CA 95035-7453 USA USA Phone +855.275.9634 Phone +408.883.6310 Fax +408.883.6358 | Zentrum Mikroelektronik Dresden AG, Japan Office 2nd Floor, Shinbashi Tokyu Bldg. 4-21-3, Shinbashi, Minato-ku Tokyo, 105-0004 Japan Phone +81.3.6895.7410 Fax +81.3.6895.7301 | ZMD FAR EAST, Ltd. 3F, No. 51, Sec. 2, Keelung Road 11052 Taipei Taiwan Phone +886.2.2377.8189 Fax +886.2.2377.8199 | Zentrum Mikroelektronik Dresden AG, Korea Office U-space 1 Building 11th Floor, Unit JA-1102 670 Sampyeong-dong Bundang-gu, Seongnam-si Gyeonggi-do, 463-400 Korea Phone +82.31.950.7679 Fax +82.504.841.3026 |
| European Technical Support Phone +49.351.8822.7.772 Fax +49.351.8822.87.772 | DISCLAIMER: This information applies to a product under development. Its characteristics and specifications are subject to change without notice. Zentrum Mikroelektronik Dresden AG (ZMD AG) assumes no obligation regarding future manufacture unless otherwise agreed to in writing. The information furnished hereby is believed to be true and accurate. However, under no circumstances shall ZMD AG be liable to any customer, licensee, or any other third party for any special, indirect, incidental, or consequential damages of any kind or nature whatsoever arising out of or in any way related to the furnishing, performance, or use of this technical data. ZMD AG hereby expressly disclaims any liability of ZMD AG to any customer, licensee or any other third party, and any such customer, licensee and any other third party hereby waives any liability of ZMD AG for any damages in connection with or arising out of the furnishing, performance or use of this technical data, whether based on contract, warranty, tort (including negligence), strict liability, or otherwise. | | | |
| European Sales (Stuttgart) Phone +49.711.674517.55 Fax +49.711.674517.87955 | | | | |

Mouser Electronics

Authorized Distributor

Click to View Pricing, Inventory, Delivery & Lifecycle Information:

ZMDI:

[ZSPM9015ZI1R](#) [ZSPM8015-KIT](#)