

Terminator™ II TMCX Cable Glands

For use with metal-clad, TECK,
unarmoured and tray cable



Crouse-Hinds
by **EATON**

Terminator™ II TMCX Cable Glands



The ideal gland for terminating cable in hazardous locations

The Terminator™ II TMCX Cable Gland is an armoured barrier, non-armoured barrier and TECK armoured gland used to terminate cable in hazardous locations. Its unique design features, coupled with our new fast curing Chico® LiquidSeal compound, make the Terminator™ II TMCX Cable Gland the easiest and safest solution available.

Cable Types:

- Metal-clad and TECK (interlocked and continuously welded corrugated armoured) cable
- Unarmoured and tray cable

Certifications and Compliances:

- Class I, Division 1, Groups A, B, C, D
- Class II, Groups E, F, G
- Class III
- NEMA 6P
- UL/cULus Listed - File No. E122485
- IECEx/ATEX (Pending)

Features and Benefits:

- Designed to minimize the opportunity for incorrect assembly
- Simple selection process and field preparation aids to ensure the right gland is selected every time
- Full coverage of all popular cables and hub sizes, ensuring a perfect seal in all instances
- Use of nickel-plated brass and stainless steel to increase corrosion resistance and maintain integrity in the harshest environments
- Chico® LiquidSeal, an innovative liquid compound with fast gel and cure times, reduces waiting times
- Complete with integral dam to facilitate liquid pour
- Integral union design reduces the number of times the gland has to be assembled and disassembled during installation
- Mating components have generous lead-ins to ensure that assembly is as trouble-free as possible, even with the heaviest cables
- Use of neoprene seal allows use in temperatures from -40°C to +60°C; for specific temperature information, please contact your local sales representative
- Metric size threads allow interfacing to European machinery
- Wide range of global certifications and approvals

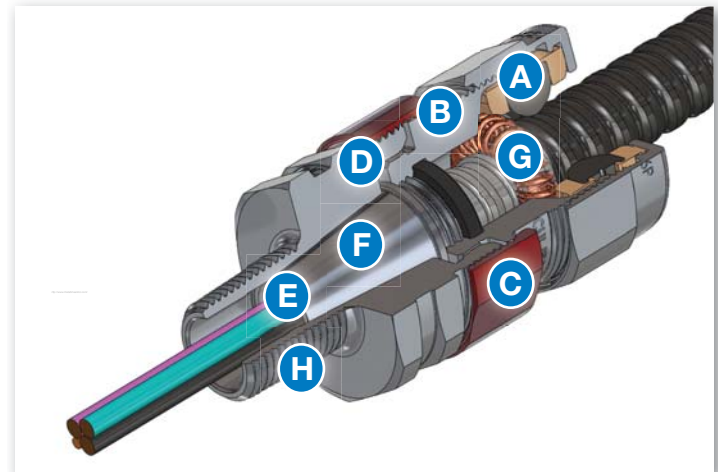

Design Features:

- Ⓐ Captive sealing and back nut - the use of slip rings with snap-in features enables the TMCX to retain all of the components in the entry end of the gland.
- Ⓑ Integral union - the design allows for a two-piece assembly gland, minimizing tightening and loosening of nuts.
- Ⓒ Red anodized nut - this hard-wearing, permanent, consistent coating is standard on all units.
- Ⓓ Anti-rotation feature - for single tool assembly; the splined shaft ensures that the two assemblies lock together and do not rotate during assembly.
- Ⓔ Barrier compounds - Chico® LiquidSeal or standard TSC epoxy compound options allow for rapid curing and assembly in any orientation.
- Ⓕ Conical compound chamber - ensures that double the misalignment can be accepted without the risk of binding.
- Ⓖ Captive garter spring - copper flashed stainless steel ensures good connectivity, strength and corrosion resistance.
- Ⓗ NPT and ISO threads - entire range of cable glands are available with either NPT or metric threads in all materials.

Multiple cable ranges per hub size for simplified selection

Selection Table:

Entry Thread 'C'	NPT Catalog No.	Entry Thread 'C' (Metric Option)	Metric Catalog No.	Over Conductors O.D. Max. Inches 'G'	'A' Armour O.D.		'B' Cable O.D.†		Across Corners 'D'	Thread Length NPT 'E' (Metric mm.)	Length 'F'
					Min.	Max.	Min.	Max.			
½"	TMCX050 1	M20	TMCXM20 1	0.480	0.40 (10.16)	0.86 (21.84)	0.49 (12.45)	0.90 (22.86)	1.56 (39.62)	1.00 (25.40)	3.05 (77.47)
½"	TMCX050 2	M20	TMCXM20 2	0.480	0.56 (14.22)	1.14 (28.96)	0.65 (16.51)	1.18 (29.97)	1.99 (50.55)	1.00 (25.40)	3.18 (80.77)
¾"	TMCX075 1	M25	TMCXM25 1	0.713	0.40 (10.16)	0.86 (21.84)	0.49 (12.45)	0.90 (22.86)	1.56 (39.62)	1.00 (25.40)	3.05 (77.47)
¾"	TMCX075 2	M25	TMCXM25 2	0.713	0.56 (14.22)	1.14 (28.96)	0.65 (16.51)	1.18 (29.97)	1.99 (50.55)	1.00 (25.40)	3.18 (80.77)
1"	TMCX100 1	M32	TMCXM32 1	0.939	0.56 (14.22)	1.14 (28.96)	0.65 (16.51)	1.18 (29.97)	1.99 (50.55)	1.08 (27.40)	3.18 (80.77)
1"	TMCX100 2	M32	TMCXM32 2	0.939	0.78 (19.81)	1.35 (34.29)	0.87 (22.10)	1.39 (35.31)	2.24 (56.90)	1.08 (27.40)	3.30 (83.82)
1-¼"	TMCX125 1	M40	TMCXM40 1	1.172	0.78 (19.81)	1.35 (34.29)	0.87 (22.10)	1.39 (35.31)	2.24 (56.90)	1.08 (27.40)	3.30 (83.82)

*All dimensions in inches; metric millimeters shown in parenthesis. Sizes 1-½" and above will be available soon.
†When making your cable gland selection based on Cable O.D., be sure to also observe the Over Conductors O.D. dimension.

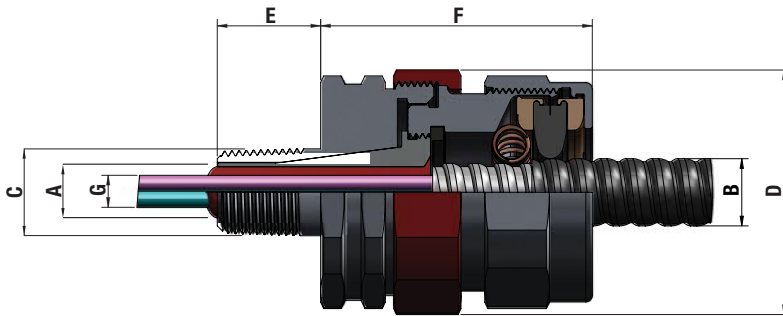

Catalog Numbering System:

TMCX

050

1

NP

L

Hub Size

NPT	Hub (in.)	Metric	Hub (mm.)
050	½"	M20	20
075	¾"	M25	25
100	1"	M32	32
125	1-¼"	M40	40

Cable Sealing Range

Hub Size Code	Thread	Sealing Range Code	Standard Cable Sealing Range
050	½"	NPT	1 0.49" - 0.90"
			2 0.65" - 1.18"
075	¾"	NPT	1 0.49" - 0.90"
			2 0.65" - 1.18"
100	1"	NPT	1 0.65" - 1.18"
			2 0.87" - 1.39"
125	1-¼"	NPT	1 0.87" - 1.39"
M20	M20	ISO	1 12.4 mm - 22.8 mm
			2 16.5 mm - 29.9 mm
M25	M25	ISO	1 12.4 mm - 22.8 mm
			2 16.5 mm - 29.9 mm
M32	M32	ISO	1 16.5 mm - 29.9 mm
			2 22.0 mm - 35.3 mm
M40	M40	ISO	1 22.0 mm - 35.3 mm

Material

BLANK	Aluminum
SS	316 Stainless Steel
NP	Nickel-plated Brass

Compound Type

BLANK	TSC
L	Liquid

Chico® LiquidSeal

NEW!

- Mixing time: 2 minutes
- Application: pour/gun
- Gel time: 15-30 minutes†
- Full cure/return to service time: 2 hours†
- Available for installation in vertical position
- Integral dam means no packing or taping to prevent liquid leakage



TSC Epoxy Compound

- Mixing time: 5 minutes
- Application: by hand
- Full cure time: 24 hours
- Available for installation in any orientation



Chico® LiquidSeal Cat. No.	Size (ml.)	Std. Carton Qty.
LSC 10	10 ml.	10
LSC 20	20 ml.	10
LSC 50	50 ml.	5

TSC Epoxy Compound Cat. No.	Tube Size (oz.)	Std. Carton Qty.
TSC05	0.5 oz.	10
TSC1	1.0 oz.	10
TSC4	4.0 oz.	5

†At 20°C ambient temperature.

For more information:

If further assistance is required, please contact an authorized Eaton Distributor, Sales Office, or Customer Service Department.

U.S. (Global Headquarters):**Eaton's Crouse-Hinds Business**

Wolf & Seventh North Streets
Syracuse, NY 13221
(866) 764-5454
FAX: (315) 477-5179
FAX Orders Only: (866) 653-0640
crouse.customerctr@cooperindustries.com

Canada:**Cooper Crouse-Hinds Canada**

Toll Free: 800-265-0502
FAX: (800) 263-9504
FAX Orders only: (866) 653-0645

Mexico/Latin America/Caribbean:**Cooper Crouse-Hinds, S.A. de C.V.**

52-555-804-4000
FAX: 52-555-804-4020
mxmercadotecnia@cooperindustries.com

Europe (Germany):**Cooper Crouse-Hinds GmbH**

49 (0) 6271 806-500
49 (0) 6271 806-476
sales.CCH.de@cooperindustries.com

Middle East (Dubai):**Cooper Crouse-Hinds LLC**

971 4 4272500
FAX: 971 4 4298521
sales.CCH.me@cooperindustries.com

Singapore:**Cooper Crouse-Hinds Pte. Ltd.**

65-6645-9888
FAX: 65-6297-4819
chsi-sales@cooperindustries.com

China:**Cooper Crouse-Hinds Pte. Ltd.**

86-21-2899-3600
FAX: 86-21-2899-4055
cchsals@cooperindustries.com

Korea:**Cooper Crouse-Hinds Korea**

82-2-3484-6783
82-2-3484-6778
CCHK-sales@cooperindustries.com

Australia:**Cooper Electrical Australia**

61-2-8787-2777
FAX: 61-2-9609-2342
CEASales@cooperindustries.com

India:**Cooper India Pvt. Ltd.**

91-124-4683888
FAX: 91-124-4683899
cchindia@cooperindustries.com