

## HX316C10FK2/8

8GB (4GB 512M x 64-Bit x 2 pcs.)  
 DDR3-1600 CL10 240-Pin DIMM Kit



### SPECIFICATIONS

CL(IDD)	10 cycles
Row Cycle Time (tRCmin)	48.125ns (min.)
Refresh to Active/Refresh Command Time (tRFCmin)	260ns (min.)
Row Active Time (tRASmin)	37.5ns (min.)
Maximum Operating Power	TBD W* (per module)
UL Rating	94 V - 0
Operating Temperature	0° C to 85° C
Storage Temperature	-55° C to +100° C

\*Power will vary depending on the SDRAM used.

### DESCRIPTION

HyperX HX316C10FK2/8 is a kit of two 512M x 64-bit (4GB) DDR3-1600 CL10 SDRAM (Synchronous DRAM) 1Rx8 memory modules, based on eight 512M x 8-bit DDR3 FBGA components per module. Total kit capacity is 8GB. Each module kit has been tested to run at DDR3-1600 at a low latency timing of 10-10-10 at 1.5V. Additional timing parameters are shown in the PnP Timing Parameters section below. The JEDEC standard electrical and mechanical specifications are as follows:

**Note:** The PnP feature offers a range of speed and timing options to support the widest variety of processors and chipsets. Your maximum speed will be determined by your BIOS.

### PnP JEDEC TIMING PARAMETERS:

- DDR3-1600 CL10-10-10 @1.5V
- DDR3-1333 CL9-9-9 @1.5V
- DDR3-1066 CL7-7-7 @1.5V

### FEATURES

- JEDEC standard 1.5V (1.425V ~1.575V) Power Supply
- VDDQ = 1.5V (1.425V ~ 1.575V)
- 800MHz fCK for 1600Mb/sec/pin
- 8 independent internal bank
- Programmable CAS Latency: 11, 10, 9, 8, 7, 6
- Programmable Additive Latency: 0, CL - 2, or CL - 1 clock
- 8-bit pre-fetch
- Burst Length: 8 (Interleave without any limit, sequential with starting address "000" only), 4 with tCCD = 4 which does not allow seamless read or write [either on the fly using A12 or MRS]
- Bi-directional Differential Data Strobe
- Internal(self) calibration : Internal self calibration through ZQ pin (RZQ : 240 ohm ± 1%)
- On Die Termination using ODT pin
- Average Refresh Period 7.8us at lower than TCASE 85°C, 3.9us at 85°C < TCASE ≤ 95°C
- Asynchronous Reset
- Height 1.291" (32.80mm) w/heatsink, single sided component

Continued >>

### MODULE WITH HEAT SPREADER

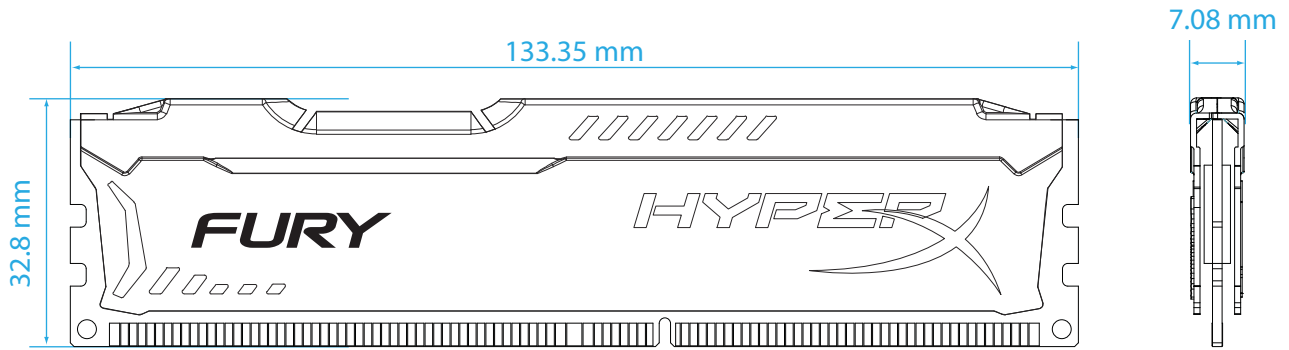

### MODULE DIMENSIONS

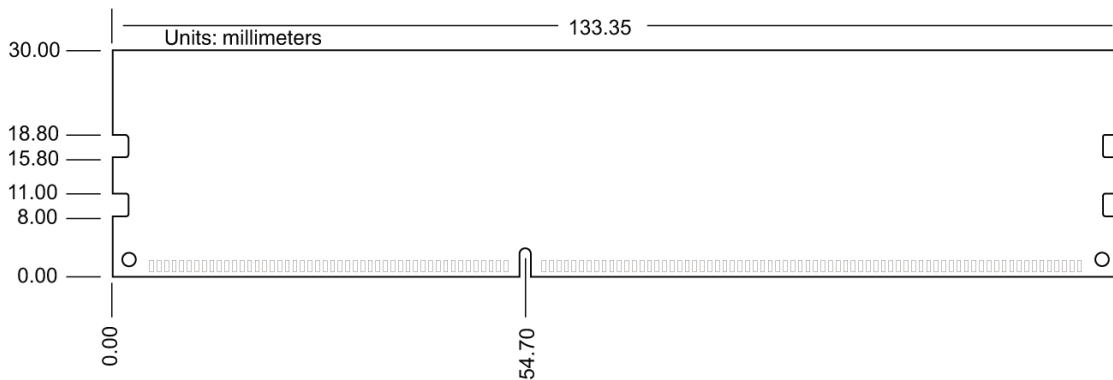
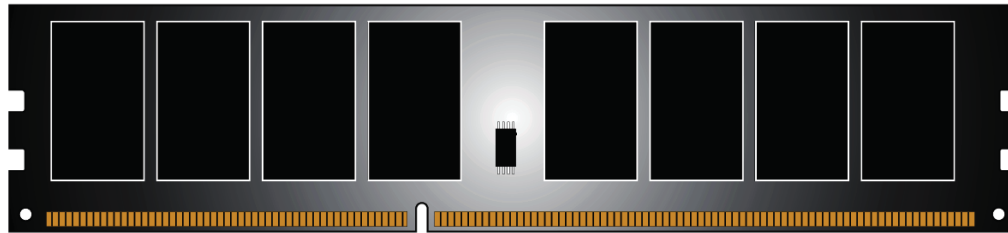
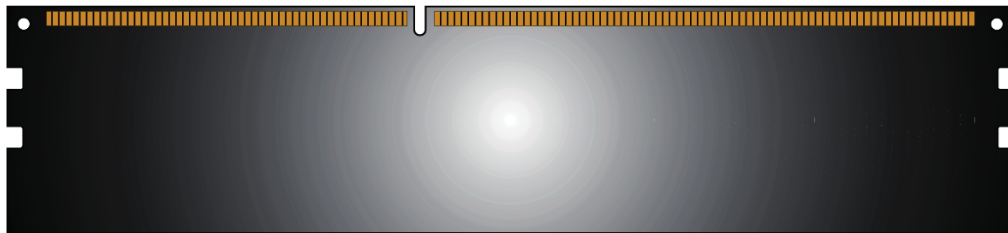

FOR MORE INFORMATION, GO TO [WWW.KINGSTON.COM/HYPERX](http://WWW.KINGSTON.COM/HYPERX)

All Kingston products are tested to meet our published specifications. Some motherboards or system configurations may not operate at the published HyperX memory speeds and timing settings. Kingston does not recommend that any user attempt to run their computers faster than the published speed. Overclocking or modifying your system timing may result in damage to computer components.