



**8XC196Lx Supplement to  
8XC196Kx, 8XC196Jx,  
87C196CA User's Manual**

**August 2004**

Order Number: 272973-003



Information in this document is provided in connection with Intel products. No license, express or implied, by estoppel or otherwise, to any intellectual property rights is granted by this document. Except as provided in Intel's Terms and Conditions of Sale for such products, Intel assumes no liability whatsoever, and Intel disclaims any express or implied warranty, relating to sale and/or use of Intel products including liability or warranties relating to fitness for a particular purpose, merchantability, or infringement of any patent, copyright or other intellectual property right. Intel products are not intended for use in medical, life saving, or life sustaining applications.

Intel may make changes to specifications and product descriptions at any time, without notice.

Designers must not rely on the absence or characteristics of any features or instructions marked "reserved" or "undefined." Intel reserves these for future definition and shall have no responsibility whatsoever for conflicts or incompatibilities arising from future changes to them.

The 8XC196Lx, 8XC196Kx, 8XC196Jx and 87C196CA microprocessors may contain design defects or errors known as errata which may cause the products to deviate from published specifications. Current characterized errata are available on request.

Contact your local Intel sales office or your distributor to obtain the latest specifications and before placing your product order.

Copies of documents which have an ordering number and are referenced in this document, or other Intel literature may be obtained by calling 1-800-548-4725 or by visiting Intel's website at <http://www.intel.com>.

Copyright © Intel Corporation, 2004

\*Third-party brands and names are the property of their respective owners.

**CHAPTER 1**

**GUIDE TO THIS MANUAL**

1.1 MANUAL CONTENTS ..... 1-1

1.2 RELATED DOCUMENTS ..... 1-2

**CHAPTER 2**

**ARCHITECTURAL OVERVIEW**

2.1 MICROCONTROLLER FEATURES ..... 2-1

2.2 BLOCK DIAGRAM ..... 2-2

2.3 INTERNAL TIMING ..... 2-2

2.4 EXTERNAL TIMING ..... 2-5

2.5 INTERNAL PERIPHERALS ..... 2-6

    2.5.1 I/O Ports ..... 2-7

    2.5.2 Synchronous Serial I/O Port ..... 2-7

    2.5.3 Event Processor Array ..... 2-7

    2.5.4 J1850 Communications Controller ..... 2-7

2.6 DESIGN CONSIDERATIONS ..... 2-7

**CHAPTER 3**

**ADDRESS SPACE**

3.1 ADDRESS PARTITIONS ..... 3-1

3.2 REGISTER FILE ..... 3-2

3.3 PERIPHERAL SPECIAL-FUNCTION REGISTERS ..... 3-4

3.4 WINDOWING ..... 3-6

**CHAPTER 4**

**STANDARD AND PTS INTERRUPTS**

4.1 INTERRUPT SOURCES, VECTORS, AND PRIORITIES ..... 4-1

4.2 INTERRUPT REGISTERS ..... 4-2

    4.2.1 Interrupt Mask Registers ..... 4-3

    4.2.2 Interrupt Pending Registers ..... 4-4

    4.2.3 Peripheral Transaction Server Registers ..... 4-6

**CHAPTER 5**

**I/O PORTS**

5.1 I/O PORTS OVERVIEW ..... 5-1

5.2 INTERNAL STRUCTURE FOR PORTS 1, 2, 5, AND 6 (BIDIRECTIONAL PORTS) .... 5-1

    5.2.1 Configuring Ports 1, 2, 5, and 6 (Bidirectional Ports) ..... 5-3

    5.2.2 Special Bidirectional Port Considerations ..... 5-4

5.3 INTERNAL STRUCTURE FOR PORTS 3 AND 4 (ADDRESS/DATA BUS) ..... 5-5

**CHAPTER 6****SYNCHRONOUS SERIAL I/O PORT**

|     |                            |     |
|-----|----------------------------|-----|
| 6.1 | SSIO 0 CLOCK REGISTER..... | 6-1 |
| 6.2 | SSIO 1 CLOCK REGISTER..... | 6-2 |

**CHAPTER 7****EVENT PROCESSOR ARRAY**

|       |  |     |
|-------|--|-----|
| 7.1   | EPA FUNCTIONAL OVERVIEW .....                | 7-1 |
| 7.1.1 | EPA Mask Registers .....                     | 7-4 |
| 7.1.2 | EPA Pending Registers .....                  | 7-5 |
| 7.1.3 | EPA Interrupt Priority Vector Register ..... | 7-6 |

**CHAPTER 8****J1850 COMMUNICATIONS CONTROLLER**

|         |  |      |
|---------|--|------|
| 8.1     | J1850 FUNCTIONAL OVERVIEW.....                               | 8-1  |
| 8.2     | J1850 CONTROLLER SIGNALS AND REGISTERS.....                  | 8-3  |
| 8.3     | J1850 CONTROLLER OPERATION .....                             | 8-4  |
| 8.3.1   | Control State Machine .....                                  | 8-4  |
| 8.3.1.1 | Cyclic Redundancy Check Generator .....                      | 8-4  |
| 8.3.1.2 | Bus Contention .....   | 8-5  |
| 8.3.1.3 | Bit Arbitration .....  | 8-5  |
| 8.3.1.4 | Error Detection .....  | 8-5  |
| 8.3.2   | Symbol Synchronization and Timing Circuitry .....            | 8-5  |
| 8.3.2.1 | Clock Prescaler .....  | 8-6  |
| 8.3.2.2 | Digital Filter .....   | 8-6  |
| 8.3.2.3 | Delay Compensation .....                                     | 8-6  |
| 8.3.2.4 | Symbol Encoding and Decoding .....                           | 8-6  |
| 8.3.3   | Bit Arbitration Example .....                                | 8-7  |
| 8.4     | MESSAGE FRAMES.....  | 8-8  |
| 8.4.1   | Standard Messaging .....                                     | 8-9  |
| 8.4.1.1 | Header .....   | 8-9  |
| 8.4.1.2 | CRC Byte .....   | 8-9  |
| 8.4.1.3 | Normalization Bit .....                                      | 8-9  |
| 8.4.1.4 | Start and End Message Frame Symbols .....                    | 8-10 |
| 8.4.2   | In-frame Response Messaging .....                            | 8-12 |
| 8.4.2.1 | IFR Messaging Type 1: Single Byte, Single Responder .....    | 8-12 |
| 8.4.2.2 | IFR Messaging Type 2: Single Byte, Multiple Responders ..... | 8-12 |
| 8.4.2.3 | IFR Messaging Type 3: Multiple Bytes, Single Responder ..... | 8-13 |
| 8.5     | TRANSMITTING AND RECEIVING MESSAGES .....                    | 8-13 |
| 8.5.1   | Transmitting Messages .....                                  | 8-13 |
| 8.5.2   | Receiving Messages .....                                     | 8-15 |
| 8.5.3   | IFR Messages .....   | 8-16 |

|       |   |      |
|-------|---|------|
| 8.6   | PROGRAMMING THE J1850 CONTROLLER .....                          | 8-16 |
| 8.6.1 | Programming the J1850 Command (J_CMD) Register .....            | 8-16 |
| 8.6.2 | Programming the J1850 Configuration (J_CFG) Register .....      | 8-18 |
| 8.6.3 | Programming the J1850 Delay Compensation (J_DLY) Register ..... | 8-19 |
| 8.6.4 | Programming the J1850 Status (J_STAT) Register .....            | 8-21 |

**CHAPTER 9**

**MINIMUM HARDWARE CONSIDERATIONS**

|     |  |     |
|-----|--|-----|
| 9.1 | IDENTIFYING THE RESET SOURCE.....                    | 9-1 |
| 9.2 | DESIGN CONSIDERATIONS FOR 8XC196LA, LB, AND LD ..... | 9-2 |

**CHAPTER 10**

**SPECIAL OPERATING MODES**

|      |                                      |      |
|------|--------------------------------------|------|
| 10.1 | INTERNAL TIMING.....                 | 10-1 |
| 10.2 | ENTERING AND EXITING ONCE MODE ..... | 10-2 |

**CHAPTER 11**

**PROGRAMMING THE NONVOLATILE MEMORY**

|      |   |      |
|------|---|------|
| 11.1 | SIGNATURE WORD AND PROGRAMMING VOLTAGE VALUES.....    | 11-1 |
| 11.2 | OTPROM ADDRESS MAP .....                              | 11-1 |
| 11.3 | SLAVE PROGRAMMING CIRCUIT AND ADDRESS MAP .....       | 11-2 |
| 11.4 | SERIAL PORT PROGRAMMING CIRCUIT AND ADDRESS MAP ..... | 11-4 |

**APPENDIX A**

**SIGNAL DESCRIPTIONS**

|     |                                       |     |
|-----|---------------------------------------|-----|
| A.1 | FUNCTIONAL GROUPINGS OF SIGNALS ..... | A-1 |
| A.2 | DEFAULT CONDITIONS.....               | A-7 |

**GLOSSARY**

## FIGURES

www.DataSheet4U.com

| Figure | Page   |
|--------|--|
| 2-1    | 8XC196Lx Block Diagram .....2-2                                      |
| 2-2    | Clock Circuitry (87C196LA, LB Only) .....2-3                         |
| 2-3    | Internal Clock Phases (Assumes PLL is Bypassed).....2-4              |
| 2-4    | Effect of Clock Mode on Internal CLKOUT Frequency.....2-5            |
| 2-5    | Unerasable PROM 1 (USFR1) Register (LA, LB Only) .....2-6            |
| 3-1    | Register File Address Map .....3-3                                   |
| 4-1    | Interrupt Mask (INT_MASK) Register.....4-3                           |
| 4-2    | Interrupt Mask 1 (INT_MASK1) Register.....4-4                        |
| 4-3    | Interrupt Pending (INT_PEND) Register .....4-5                       |
| 4-4    | Interrupt Pending 1 (INT_PEND1) Register .....4-6                    |
| 4-5    | PTS Select (PTSSSEL) Register .....4-7                               |
| 4-6    | PTS Service (PTSSRV) Register .....4-8                               |
| 5-1    | Ports 1, 2, 5, and 6 Internal Structure (87C196LA, LB Only) .....5-3 |
| 5-2    | Ports 3 and 4 Internal Structure (87C196LA, LB Only) .....5-6        |
| 6-1    | SSIO 0 Clock (SSIO0_CLK) Register.....6-1                            |
| 6-2    | SSIO 1 Clock (SSIO1_CLK) Register.....6-2                            |
| 7-1    | EPA Block Diagram (87C196LA, LB Only).....7-2                        |
| 7-2    | EPA Block Diagram (83C196LD Only) .....7-3                           |
| 7-3    | EPA Interrupt Mask (EPA_MASK) Register .....7-4                      |
| 7-4    | EPA Interrupt Mask 1 (EPA_MASK1) Register .....7-4                   |
| 7-5    | EPA Interrupt Pending (EPA_PEND) Register.....7-5                    |
| 7-6    | EPA Interrupt Pending 1 (EPA_PEND1) Register.....7-5                 |
| 7-7    | EPA Interrupt Priority Vector Register (EPAIPV).....7-6              |
| 8-1    | Integrated J1850 Communications Protocol Solution.....8-1            |
| 8-2    | J1850 Communications Controller Block Diagram.....8-2                |
| 8-3    | Huntzicker Symbol Definition for J1850.....8-7                       |
| 8-4    | Typical VPW Waveform.....8-7   |
| 8-5    | Bit Arbitration Example.....8-8                                      |
| 8-6    | J1850 Message Frames.....8-9   |
| 8-7    | Huntzicker Symbol Definition for the Normalization Bit .....8-10     |
| 8-8    | Definition for Start and End of Frame Symbols .....8-11              |
| 8-9    | IFR Type 1 Message Frame.....8-12                                    |
| 8-10   | IFR Type 2 Message Frame.....8-13                                    |
| 8-11   | IFR Type 3 Message Frame.....8-13                                    |
| 8-13   | J1850 Transmit Message Structure.....8-14                            |
| 8-12   | J1850 Transmitter (J_TX) Register .....8-14                          |
| 8-15   | J1850 Receive Message Structure.....8-15                             |
| 8-14   | J1850 Receiver (J_RX) Register .....8-15                             |
| 8-16   | J1850 Command (J_CMD) Register .....8-17                             |
| 8-17   | J1850 Configuration (J_CFG) Register .....8-18                       |
| 8-18   | J1850 Delay (J_DLY) Register.....8-20                                |
| 8-19   | J1850 Status (J_STAT) Register.....8-21                              |
| 9-1    | Reset Source (RSTSRC) Register .....9-1                              |
| 10-1   | Clock Circuitry (87C196LA, LB Only) .....10-2                        |

## FIGURES

[www.DataSheet4U.com](http://www.DataSheet4U.com)

| Figure |                                      | Page |
|--------|--------------------------------------|------|
| 11-1   | Slave Programming Circuit.....       | 11-3 |
| 11-2   | Serial Port Programming Circuit..... | 11-4 |
| A-1    | 87C196LA 52-pin PLCC Package.....    | A-3  |
| A-2    | 87C196LB 52-pin PLCC Package.....    | A-5  |
| A-3    | 83C196LD 52-pin PLCC Package.....    | A-7  |

## TABLES

[www.DataSheet4U.com](http://www.DataSheet4U.com)

| <b>Table</b> | <b>Page</b>   |
|--------------|---|
| 1-1          | Related Documents .....1-2  |
| 2-1          | Features of the 8XC196Lx and 8XC196Kx Product Families .....2-1                   |
| 2-2          | State Times at Various Frequencies .....2-4                                       |
| 2-3          | Relationships Between Input Frequency, Clock Multiplier, and State Times .....2-5 |
| 2-4          | UPROM Programming Values and Locations .....2-6                                   |
| 3-1          | Address Map .....3-1  |
| 3-2          | Register File Memory Addresses .....3-3   |
| 3-3          | 8XC196Lx Peripheral SFRs .....3-4   |
| 3-4          | Windows .....3-6  |
| 4-1          | Interrupt Sources, Vectors, and Priorities .....4-2                               |
| 5-1          | Microcontroller Ports .....5-1  |
| 7-1          | EPA Channels .....7-1   |
| 7-2          | EPA Interrupt Priority Vectors .....7-6   |
| 8-1          | J1850 Controller Signals .....8-3   |
| 8-2          | Control and Status Registers .....8-3   |
| 8-3          | Relationships Between Input Frequency, PLL, and Prescaler Bits .....8-6           |
| 8-4          | Huntzicker Symbol Timing Characteristics .....8-11                                |
| 11-1         | Signature Word and Programming Voltage Values .....11-1                           |
| 11-2         | 87C196LA, LB OTPROM Address Map .....11-2   |
| 11-3         | Slave Programming Mode Address Map .....11-3                                      |
| 11-4         | Serial Port Programming Mode Address Map .....11-5                                |
| A-1          | 87C196LA Signals Arranged by Functional Categories .....A-2                       |
| A-2          | 87C196LB Signals Arranged by Functional Categories .....A-4                       |
| A-3          | 83C196LD Signals Arranged by Functional Categories .....A-6                       |
| A-4          | Definition of Status Symbols .....A-7   |
| A-5          | 87C196LA, LB Default Signal Conditions .....A-8                                   |
| A-6          | 83C196LD Default Signal Conditions .....A-9                                       |



# Guide to This Manual



# CHAPTER 1

## GUIDE TO THIS MANUAL

This document is a supplement to the *8XC196Kx, 8XC196Jx, 87C196CA Microcontroller Family User's Manual*. It describes the differences between the 8XC196Lx and the 8XC196Kx family of microcontrollers. For information not found in this supplement, please consult the *8XC196Kx, 8XC196Jx, 87C196CA Microcontroller Family User's Manual* (order number 272258) or the 8XC196Lx datasheets listed in the “Related Documents” section of this chapter.

### 1.1 MANUAL CONTENTS

This supplement contains several chapters, an appendix, a glossary, and an index. This chapter, Chapter 1, provides an overview of the supplement. This section summarizes the contents of the remaining chapters and appendixes. The remainder of this chapter provides references to related documentation.

**Chapter 2 — Architectural Overview** — compares the features of the 8XC196Lx microcontroller family with those of the 8XC196Kx microcontroller family and describes the 87C196LA, LB internal clock circuitry.

**Chapter 3 — Address Space** — describes the addressable memory space of the 52-pin 8XC196Lx, lists the peripheral special-function registers (SFRs), and provides tables of WSR values for windowing higher memory into the lower register file for direct access.

**Chapter 4 — Standard and PTS Interrupts** — describes the additional interrupts for the 87C196LB's J1850 communications controller peripheral and the SFRs that support those interrupts.

**Chapter 5 — I/O Ports** — describes the port differences and explains the change in the port reset state from a “logic 1” to a “logic 0” on the 87C196LA, LB.

**Chapter 6 — Synchronous Serial I/O Port** — describes the enhanced synchronous serial I/O (SSIO) port and explains how to program the two additional peripheral SFRs.

**Chapter 7 — Event Processor Array** — describes the event processor array channel differences.

**Chapter 8 — J1850 Communications Controller** — describes the 87C196LB's integrated J1850 controller and explains how to configure it.

**Chapter 9 — Minimum Hardware Considerations** — describes device reset options through the reset source register, and discusses hardware design considerations.

**Chapter 10 — Special Operating Modes** — illustrates the internal clock control circuitry of the 87C196LA, LB and describes how to enter and exit on-circuit emulation (ONCE) mode.

**Chapter 11 — Programming the Nonvolatile Memory** — describes the memory maps and recommended circuits to support programming of the 87C196LA, LB's 24 Kbytes of OTPROM.

**Appendix A — Signal Descriptions** — provides reference information for the 8XC196Lx device pins, including descriptions of the pin functions, reset status of the I/O and control pins, and package pin assignments.

**Glossary** — defines terms with special meaning used throughout this supplement.

**Index** — lists key topics with page number references.

## 1.2 RELATED DOCUMENTS

Table 1-1 lists additional documents that you may find useful in designing systems incorporating the 8XC196Lx microcontrollers.

**Table 1-1. Related Documents**

| Title and Description  | Order Number |
|--|--------------|
| <i>8XC196Kx, 8XC196Jx, 87C196CA Microcontroller Family User's Manual</i> | 272258       |
| <i>87C196LA-20 MHz CHMOS 16-Bit Microcontroller Automotive datasheet</i> | 272806       |
| <i>87C196LB-20 MHz CHMOS 16-Bit Microcontroller Automotive datasheet</i> | 272807       |
| <i>83C196LD CHMOS 16-Bit Microcontroller Automotive datasheet</i>        | 272805       |

# **Architectural Overview**





# CHAPTER 2

## ARCHITECTURAL OVERVIEW

This chapter describes architectural differences between the 8XC196Lx (87C196LA, 87C196LB, and 83C196LD) and the 8XC196Kx (8XC196Kx, 8XC196Jx, and 87C196CA) microcontroller families. Both the 8XC196Lx and the 8XC196Kx are designed for high-speed calculations and fast I/O, and share a common architecture and instruction set with few deviations. This chapter provides a high-level overview of the deviations between the two families.

### NOTE

This supplement describes two product families within the MCS<sup>®</sup> 96 microcontroller family. For brevity, the name 8XC196Lx is used when the discussion applies to all three Lx controllers. Likewise, the name 8XC196Kx is used when the discussion applies to all the Kx, Jx, and CA controllers.

## 2.1 MICROCONTROLLER FEATURES

Table 2-1 lists the features of the 8XC196Lx and the 8XC196Kx.

**Table 2-1. Features of the 8XC196Lx and 8XC196Kx Product Families**

| Device   | Pins | OTPROM/<br>EPROM/<br>ROM (1) | Register<br>RAM (2) | Code<br>RAM | I/O<br>Pins | EPA<br>Pins | SIO/<br>SSIO<br>Ports | A/D | CAN | J1850 | Ext.<br>Interrupt<br>Pins |
|----------|------|------------------------------|---------------------|-------------|-------------|-------------|-----------------------|-----|-----|-------|---------------------------|
| 87C196LA | 52   | 24 K                         | 768                 | —           | 41          | 6           | 3                     | 6   | —   | —     | 1                         |
| 87C196LB | 52   | 24 K                         | 768                 | —           | 41          | 6           | 3                     | 6   | —   | 1     | 1                         |
| 83C196LD | 52   | 16 K                         | 384                 | —           | 41          | 6           | 3                     | —   | —   | —     | 1                         |
| 8XC196JV | 52   | 48 K                         | 1536                | 512         | 41          | 6           | 3                     | 6   | —   | —     | 1                         |
| 8XC196KT | 68   | 32 K                         | 1024                | 512         | 56          | 10          | 3                     | 8   | —   | —     | 2                         |
| 8XC196JT | 52   | 32 K                         | 1024                | 512         | 41          | 6           | 3                     | 6   | —   | —     | 1                         |
| 87C196CA | 68   | 32 K                         | 1024                | 256         | 51          | 6           | 3                     | 6   | 1   | —     | 2                         |
| 8XC196KR | 68   | 16 K                         | 512                 | 256         | 56          | 10          | 3                     | 8   | —   | —     | 2                         |
| 8XC196JR | 52   | 16 K                         | 512                 | 256         | 41          | 6           | 3                     | 6   | —   | —     | 1                         |

#### NOTES:

- Optional. The second character of the device name indicates the presence and type of nonvolatile memory. 80C196xx = none; 83C196xx = ROM; 87C196xx = OTPROM or EPROM.
- Register RAM amounts include the 24 bytes allocated to core SFRs and the stack pointer.

## 2.2 BLOCK DIAGRAM

Figure 2-1 is a simplified block diagram that shows the major blocks within the microcontroller. Observe that the slave port peripheral does not exist on the 8XC196Lx.

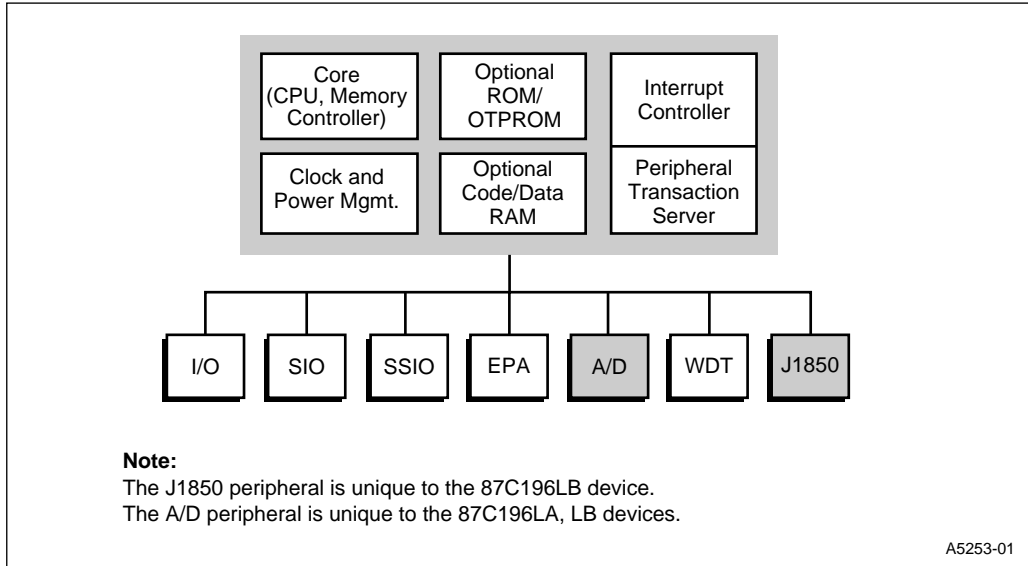

**Figure 2-1. 8XC196Lx Block Diagram**

## 2.3 INTERNAL TIMING

The 87C196LA, LB clock circuitry (Figure 2-2) implements a phase-locked loop and clock multiplier circuitry, which can substantially increase the CPU clock rate while using a lower-frequency input clock. The clock circuitry accepts an input clock signal on XTAL1 provided by an external crystal or oscillator. Depending on the value of the PLEN pin, this frequency is routed either through the phase-locked loop and multiplier or directly to the divide-by-two circuit. The multiplier circuitry can double the input frequency ( $F_{XTAL1}$ ) before the frequency ( $f$ ) reaches the divide-by-two circuitry. The clock generators accept the divided input frequency ( $f/2$ ) from the divide-by-two circuit and produce two nonoverlapping internal timing signals, PH1 and PH2. These signals are active when high.

### NOTE

This manual uses lowercase “f” to represent the internal clock frequency. For the 87C196LA and LB,  $f$  is equal to either  $F_{XTAL1}$  or  $2F_{XTAL1}$ , depending on the clock multiplier mode, which is controlled by the PLEN input pin.



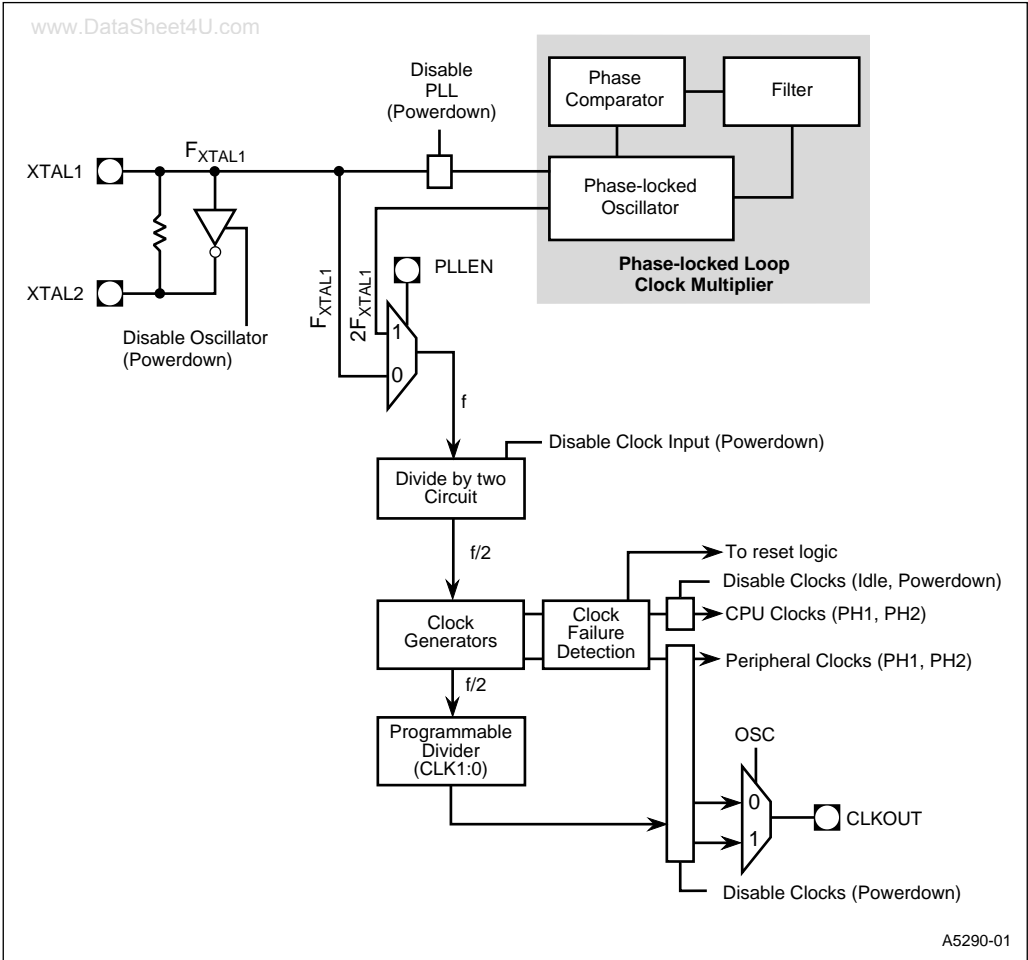
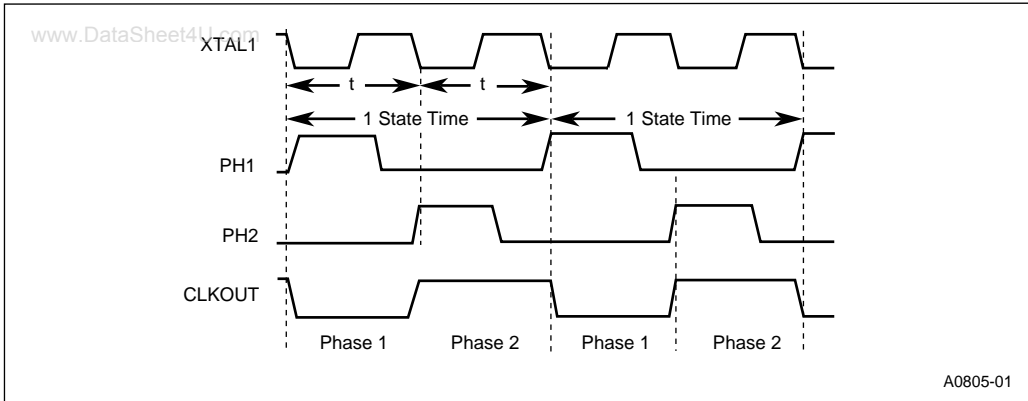

Figure 2-2. Clock Circuitry (87C196LA, LB Only)

The rising edges of PH1 and PH2 generate the internal CLKOUT signal (Figure 2-3). The clock circuitry routes separate internal clock signals to the CPU and the peripherals to provide flexibility in power management. It also outputs the CLKOUT signal on the CLKOUT pin. Because of the complex logic in the clock circuitry, the signal on the CLKOUT pin is a delayed version of the internal CLKOUT signal. This delay varies with temperature and voltage.



**Figure 2-3. Internal Clock Phases (Assumes PLL is Bypassed)**

The combined period of phase 1 and phase 2 of the internal CLKOUT signal defines the basic time unit known as a *state time* or *state*. Table 2-2 lists state time durations at various frequencies.

**Table 2-2. State Times at Various Frequencies**

| f<br>(Frequency Input to the Divide-by-two Circuit) | State Time |
|---|------------|
| 8 MHz   | 250 ns     |
| 12 MHz  | 167 ns     |
| 16 MHz  | 125 ns     |
| 20 MHz  | 100 ns     |

The following formulas calculate the frequency of PH1 and PH2, the duration of a state time, and the duration of a clock period ( $t$ ).

$$PH1 \text{ (in MHz)} = \frac{f}{2} = PH2 \qquad \text{State Time (in } \mu\text{s)} = \frac{2}{f} \qquad t = \frac{1}{f}$$

Because the device can operate at many frequencies, this manual defines time requirements (such as instruction execution times) in terms of state times rather than specific measurements. Datasheets list AC characteristics in terms of clock periods ( $t$ ; sometimes called  $T_{osc}$ ).

Figure 2-4 illustrates the timing relationships between the input frequency ( $F_{XTAL1}$ ), the operating frequency ( $f$ ), and the CLKOUT signal with each PLEN pin configuration. Table 2-3 details the relationships between the input frequency ( $F_{XTAL1}$ ), the PLEN pin, the operating frequency ( $f$ ), the clock period ( $t$ ), and state times.

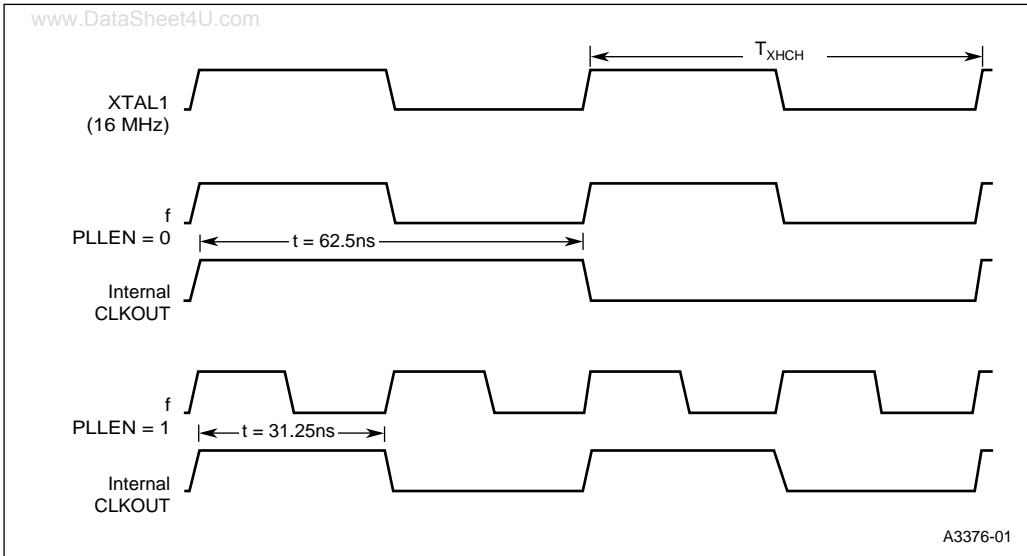

Figure 2-4. Effect of Clock Mode on Internal CLKOUT Frequency

Table 2-3. Relationships Between Input Frequency, Clock Multiplier, and State Times

| $F_{XTAL1}$<br>(Frequency on XTAL1) | PLLEN | Multiplier | f<br>(Input Frequency to the Divide-by-two Circuit) | t<br>(Clock Period) | State Time |
|-------------------------------------|-------|------------|---|---------------------|------------|
| 4 MHz                               | 0     | 1          | 4 MHz   | 250 ns              | 500 ns     |
| 8 MHz                               | 0     | 1          | 8 MHz   | 125 ns              | 250 ns     |
| 12 MHz                              | 0     | 1          | 12 MHz  | 83.5 ns             | 167 ns     |
| 16 MHz                              | 0     | 1          | 16 MHz  | 62.5 ns             | 125 ns     |
| 20 MHz                              | 0     | 1          | 20 MHz  | 50 ns               | 100 ns     |
| 4 MHz                               | 1     | 2          | 8 MHz   | 125 ns              | 250 ns     |
| 8 MHz                               | 1     | 2          | 16 MHz  | 62.5 ns             | 125 ns     |
| 10 MHz                              | 1     | 2          | 20 MHz  | 50 ns               | 100 ns     |

## 2.4 EXTERNAL TIMING

You can control the output frequency on the CLKOUT pin by programming two unerasable PROM bits. Figure 2-5 illustrates the read-only USFR1, which reflects the state of the unerasable PROM bits. You can select one of three frequencies:  $f/2$ ,  $f/4$ , or  $f/8$ . As Figure 2-2 on page 2-3 shows, the configurable divider accepts the output of the clock generators ( $f/2$ ) and further divides that frequency to produce the desired output frequency. The CLK1:0 bits control the divisor (divide  $f/2$  by either 1, 2, or 4).

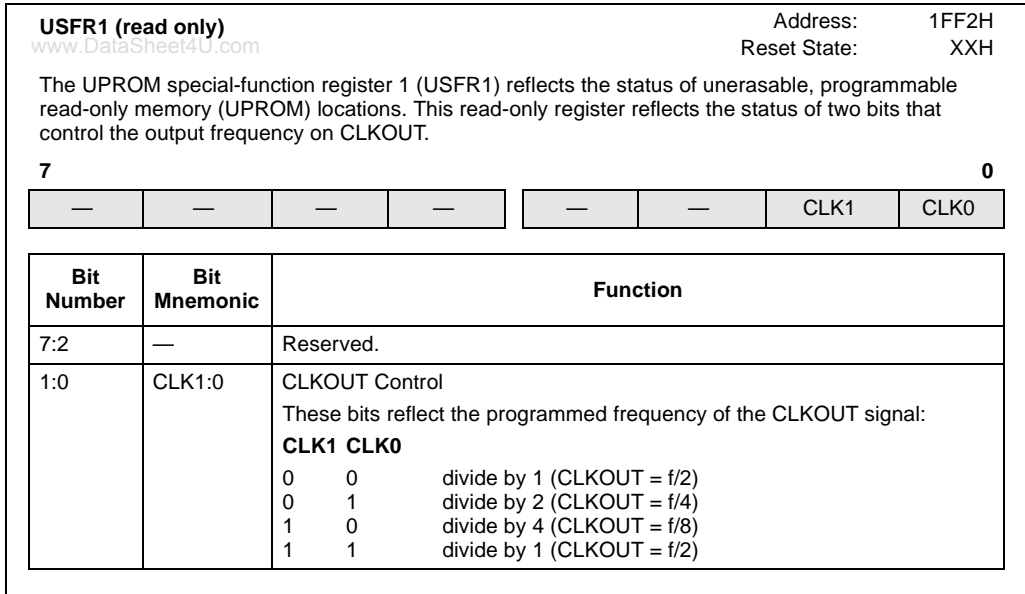

**Figure 2-5. Unerasable PROM 1 (USFR1) Register (LA, LB Only)**

To program these bits, write the correct value to the locations shown in Table 2-4 using slave programming mode. During normal operation, you can determine the values of these bits by reading the UPROM SFR (Figure 2-5).

You can verify a UPROM bit to make sure it programmed, but you cannot erase it. For this reason, Intel cannot test the bits before shipment. However, Intel does test the features that the UPROM bits enable, so the only undetectable defects are (unlikely) defects within the UPROM cells themselves.

**Table 2-4. UPROM Programming Values and Locations**

| To set this bit | Write this value | To this location |
|-----------------|------------------|------------------|
| CLK0            | 0001H            | 0768H            |
| CLK1            | 0002H            | 0728H            |

## 2.5 INTERNAL PERIPHERALS

The internal peripheral modules provide special functions for a variety of applications. This section provides a brief description of the peripherals that differ between the 8XC196Lx and the 8XC196Kx families.

### 2.5.1 I/O Ports

The I/O ports of the 8XC196Lx are functionally identical to those of the 8XC196Jx. However, on the 87C196LA and LB the reset state level of all 41 general-purpose I/O pins has changed from a weak logic “1” (wk1) to a weak logic “0” (wk0).

### 2.5.2 Synchronous Serial I/O Port

The synchronous serial I/O (SSIO) port on the 8XC196Lx has been enhanced, implementing two new special function registers (SSIO0\_CLK and SSIO1\_CLK) that allow you to select the operating mode and configure the phase and polarity of the serial clock signals.

### 2.5.3 Event Processor Array

The 8XC196Lx’s event processor array (EPA) is functionally identical to that of the 8XC196Jx, except that it has only two EPA capture/compare channels without pins instead of four. In addition the LD has no compare-only channels.

### 2.5.4 J1850 Communications Controller

The 87C196LB microcontroller has a peripheral not found on the 8XC196Kx microcontrollers or any other Lx microcontroller, the J1850 peripheral. The J1850 communications controller manages communications between multiple network nodes. This integrated peripheral supports the 10.4 Kb/s VPW (variable pulse-width) medium-speed, class B, in-vehicle network protocol. It also supports both the standard and in-frame response (IFR) message framing as specified by the *Society of Automotive Engineering (SAE) J1850* (revised May 1994) technical standards.

## 2.6 DESIGN CONSIDERATIONS

With the exception of a few new multiplexed functions, the 8XC196Lx microcontrollers are pin compatible with the 8XC196Jx microcontrollers. The 8XC196Jx microcontrollers are 52-lead versions of 8XC196Kx microcontrollers. For registers that are implemented in both the 8XC196Lx and the 8XC196Jx, configure the 8XC196Lx register as you would for the 8XC196Jx unless differences are noted in this supplement.



# Address Space







# CHAPTER 3 ADDRESS SPACE

This chapter describes the differences in the address space of the 8XC196Lx from that of the 8XC196Kx.

## 3.1 ADDRESS PARTITIONS

Table 3-1 is an address map of the 8XC196Lx and 8XC196Kx microcontroller family members.

**Table 3-1. Address Map**

| Device and Hex Address Range |              |              |              |              |              | Description   | Addressing Modes                      |
|------------------------------|--------------|--------------|--------------|--------------|--------------|---|---------------------------------------|
| CA                           | JR, KR       | LD           | LA, LB       | JT, KT       | JV           |   |                                       |
| FFFF<br>A000                 | FFFF<br>6000 | FFFF<br>6000 | FFFF<br>8000 | FFFF<br>A000 | FFFF<br>E000 | External device (memory or I/O) connected to address/data bus                                     | Indirect or indexed                   |
| 9FFF<br>2080                 | 5FFF<br>2080 | 5FFF<br>2080 | 7FFF<br>2080 | 9FFF<br>2080 | DFFF<br>2080 | Program memory (internal nonvolatile or external memory); see Note 1                              | Indirect or indexed                   |
| 207F<br>2000                 | 207F<br>2000 | 207F<br>2000 | 207F<br>2000 | 207F<br>2000 | 207F<br>2000 | Special-purpose memory (internal nonvolatile or external memory)                                  | Indirect or indexed                   |
| 1FFF<br>1FE0                 | 1FFF<br>1FE0 | 1FFF<br>1FE0 | 1FFF<br>1FE0 | 1FFF<br>1FE0 | 1FFF<br>1FE0 | Memory-mapped SFRs  | Indirect or indexed                   |
| 1FDF<br>1F00                 | 1FDF<br>1F00 | 1FDF<br>1F00 | 1FDF<br>1F00 | 1FDF<br>1F00 | 1FDF<br>1F00 | Peripheral SFRs (Includes J1850 SFRs on 87C196LB)   | Indirect, indexed, or windowed direct |
| 1EFF<br>1E00                 | —            | —            | —            | —            | —            | CAN SFRs  | Indirect, indexed, or windowed direct |
| 1DFF<br>1C00                 | 1EFF<br>1C00 | 1EFF<br>1C00 | 1EFF<br>0300 | 1EFF<br>1C00 | 1EFF<br>1E00 | External device (memory or I/O) connected to address/data bus; (future SFR expansion; see Note 2) | Indirect or indexed                   |
| —                            | —            | —            | —            | —            | 1DFF<br>1C00 | Register RAM  | Indirect, indexed, or windowed direct |

**NOTES:**

1. After a reset, the device fetches its first instruction from 2080H.
2. The content or function of these locations may change in future device revisions, in which case a program that relies on a location in this range might not function properly.

**Table 3-1. Address Map (Continued)**

| Device and Hex Address Range |              |              |              |              |              | Description   | Addressing Modes                      |
|------------------------------|--------------|--------------|--------------|--------------|--------------|---|---------------------------------------|
| CA                           | JR, KR       | LD           | LA, LB       | JT, KT       | JV           |   |                                       |
| 1BFF<br>0500                 | 1BFF<br>0500 | 1BFF<br>0600 | —            | 1BFF<br>0600 | 1BFF<br>0600 | External device (memory or I/O) connected to address/data bus   | Indirect or indexed                   |
| 04FF<br>0400                 | 04FF<br>0400 | —            | —            | 05FF<br>0400 | 05FF<br>0400 | Internal code or data RAM                                       | Indirect or indexed                   |
| —                            | 03FF<br>0200 | 05FF<br>0180 | —            | —            | —            | External device (memory or I/O) connected to address/data bus   | Indirect or indexed                   |
| 03FF<br>0100                 | 01FF<br>0100 | 017F<br>0100 | 02FF<br>0100 | 03FF<br>0100 | 03FF<br>0100 | Upper register file (general-purpose register RAM)              | Indirect, indexed, or windowed direct |
| 00FF<br>0000                 | 00FF<br>0000 | 00FF<br>0000 | 00FF<br>0000 | 00FF<br>0000 | 00FF<br>0000 | Lower register file (register RAM, stack pointer, and CPU SFRs) | Direct, indirect, or indexed          |

**NOTES:**

1. After a reset, the device fetches its first instruction from 2080H.
2. The content or function of these locations may change in future device revisions, in which case a program that relies on a location in this range might not function properly.

### 3.2 REGISTER FILE

Figure 3-1 compares the register file addresses of the 8XC196Lx and 8XC196Kx. The register file in Figure 3-1 is divided into an upper register file and a lower register file. The upper register file consists of general-purpose register RAM. The lower register file contains general-purpose register RAM along with the stack pointer (SP) and the CPU special-function registers (SFRs).

Table 3-2 lists the register file memory addresses. The RALU accesses the lower register file directly, without the use of the memory controller. It also accesses a *windowed* location directly (see “Windowing” on page 3-6). The upper register file and the peripheral SFRs can be windowed. Registers in the lower register file and registers being windowed can be accessed with register-direct addressing.

**NOTE**

The register file must not contain code. An attempt to execute an instruction from a location in the register file causes the memory controller to fetch the instruction from external memory.

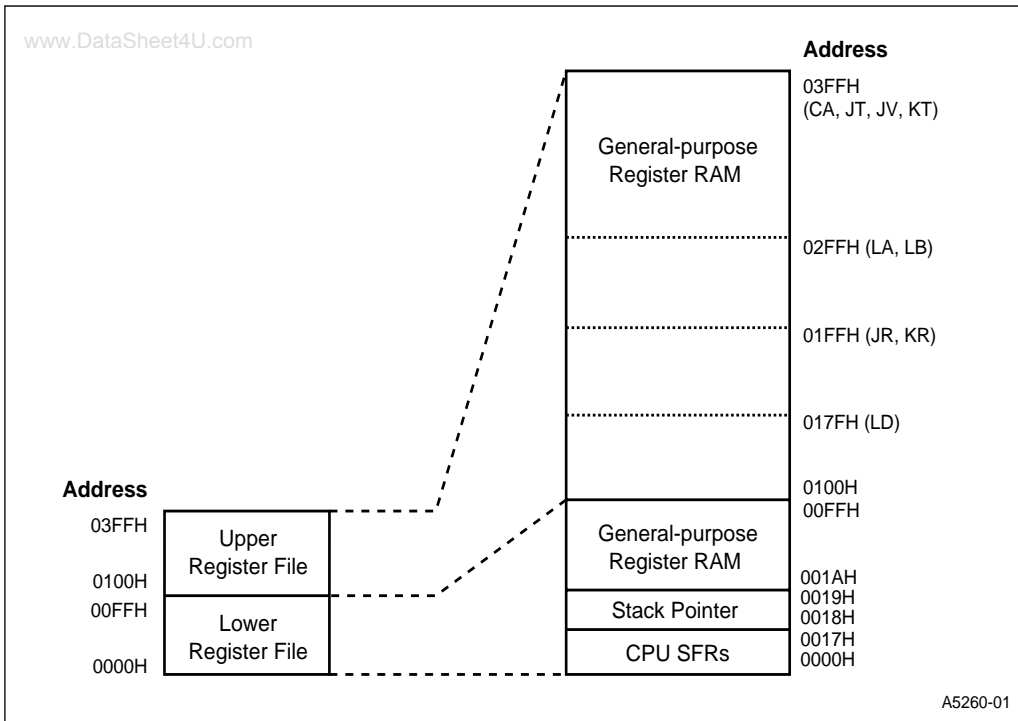

Figure 3-1. Register File Address Map

Table 3-2. Register File Memory Addresses

| Device and Hex Address Range |              |              |              |              | Description                         | Addressing Modes                      |
|------------------------------|--------------|--------------|--------------|--------------|-------------------------------------|---------------------------------------|
| JV                           | CA, JT, KT   | LA, LB       | JR, KR       | LD           |                                     |                                       |
| 1DFF<br>1C00                 | —            | —            | —            | —            | Register RAM                        | Indirect, indexed, or windowed direct |
| 03FF<br>0100                 | 03FF<br>0100 | 02FF<br>0100 | 01FF<br>0100 | 017F<br>0100 | Upper register file (register RAM)  | Indirect, indexed, or windowed direct |
| 00FF<br>001A                 | 00FF<br>001A | 00FF<br>001A | 00FF<br>001A | 00FF<br>001A | Lower register file (register RAM)  | Direct, indirect, or indexed          |
| 0019<br>0018                 | 0019<br>0018 | 0019<br>0018 | 0019<br>0018 | 0019<br>0018 | Lower register file (stack pointer) | Direct, indirect, or indexed          |
| 0017<br>0000                 | 0017<br>0000 | 0017<br>0000 | 0017<br>0000 | 0017<br>0000 | Lower register file (CPU SFRs)      | Direct, indirect, or indexed          |

### 3.3 PERIPHERAL SPECIAL-FUNCTION REGISTERS

Table 3-3 lists the peripheral SFR addresses. Highlighted addresses are unique to the 8XC196Lx.

**Table 3-3. 8XC196Lx Peripheral SFRs**

| Ports 3, 4, 5, and UPROM SFRs |                 |                       | Ports 0, 1, 2, and 6 SFRs |                 |                 |
|-------------------------------|-----------------|-----------------------|---------------------------|-----------------|-----------------|
| Address                       | High (Odd) Byte | Low (Even) Byte       | Address                   | High (Odd) Byte | Low (Even) Byte |
| 1FFE <sup>†</sup> H           | P4_PIN          | P3_PIN                | 1FDEH                     | Reserved        | Reserved        |
| 1FFCH                         | P4_REG          | P3_REG                | 1FDCH                     | Reserved        | Reserved        |
| 1FFAH                         | SLP_CON         | SLP_CMD               | 1FDAH                     | Reserved        | P0_PIN          |
| 1FF8H                         | Reserved        | SLP_STAT              | 1FD8H                     | Reserved        | Reserved        |
| 1FF6H                         | P5_PIN          | USFR                  | 1FD6H                     | P6_PIN          | P1_PIN          |
| 1FF4H                         | P5_REG          | P34_DRV               | 1FD4H                     | P6_REG          | P1_REG          |
| 1FF2H                         | P5_DIR          | <b>USFR1 (LA, LB)</b> | 1FD2H                     | P6_DIR          | P1_DIR          |
| 1FF0H                         | P5_MODE         | Reserved              | 1FD0H                     | P6_MODE         | P1_MODE         |
| 1FEEH                         | Reserved        | Reserved              | 1FCEH                     | P2_PIN          | Reserved        |
| 1FECH                         | Reserved        | Reserved              | 1FCCH                     | P2_REG          | Reserved        |
| 1FEAH                         | Reserved        | Reserved              | 1CAH                      | P2_DIR          | Reserved        |
| 1FE8H                         | Reserved        | Reserved              | 1FC8H                     | P2_MODE         | Reserved        |
| 1FE6H                         | Reserved        | Reserved              | 1FC6H                     | Reserved        | Reserved        |
| 1FE4H                         | Reserved        | Reserved              | 1FC4H                     | Reserved        | Reserved        |
| 1FE2H                         | Reserved        | Reserved              | 1FC2H                     | Reserved        | Reserved        |
| 1FE0H                         | Reserved        | Reserved              | 1FC0H                     | Reserved        | Reserved        |

<sup>†</sup> Must be addressed as a word.

Table 3-3. 8XC196Lx Peripheral SFRs (Continued)

| SIO and SSIO SFRs              |                  |                 |
|--------------------------------|------------------|-----------------|
| Address                        | High (Odd) Byte  | Low (Even) Byte |
| 1FBEH                          | Reserved         | Reserved        |
| 1FBCH                          | SP_BAUD (H)      | SP_BAUD (L)     |
| 1FBAH                          | SP_CON           | SBUF_TX         |
| 1FB8H                          | SP_STATUS        | SBUF_RX         |
| 1FB6H                          | <b>SSIO1_CLK</b> | Reserved        |
| 1FB4H                          | <b>SSIO0_CLK</b> | SSIO_BAUD       |
| 1FB2H                          | SSIO1_CON        | SSIO1_BUF       |
| 1FB0H                          | SSIO0_CON        | SSIO0_BUF       |
| A/D SFRs (LA, LB Only)         |                  |                 |
| Address                        | High (Odd) Byte  | Low (Even) Byte |
| 1FAEH                          | AD_TIME          | AD_TEST         |
| 1FACH                          | Reserved         | AD_COMMAND      |
| 1FAAH                          | AD_RESULT (H)    | AD_RESULT (L)   |
| EPA Interrupt SFRs             |                  |                 |
| Address                        | High (Odd) Byte  | Low (Even) Byte |
| 1FA8H                          | Reserved         | EPAIPV          |
| 1FA6H                          | Reserved         | EPA_PEND1       |
| 1FA4H                          | Reserved         | EPA_MASK1       |
| †1FA2H                         | EPA_PEND (H)     | EPA_PEND (L)    |
| †1FA0H                         | EPA_MASK (H)     | EPA_MASK (L)    |
| Timer 1, Timer 2, and EPA SFRs |                  |                 |
| Address                        | High (Odd) Byte  | Low (Even) Byte |
| †1F9EH                         | TIMER2 (H)       | TIMER2 (L)      |
| 1F9CH                          | Reserved         | T2CONTROL       |
| †1F9AH                         | TIMER1 (H)       | TIMER1 (L)      |
| 1F98H                          | Reserved         | T1CONTROL       |
| 1F96H                          | Reserved         | Reserved        |
| 1F94H                          | Reserved         | Reserved        |
| 1F92H                          | Reserved         | <b>RST_SRC</b>  |
| 1F90H                          | Reserved         | Reserved        |
| EPA SFRs                       |                  |                 |
| Address                        | High (Odd) Byte  | Low (Even) Byte |
| †1F8EH                         | COMP1_TIME (H)   | COMP1_TIME (L)  |
| 1F8CH                          | Reserved         | COMP1_CON       |
| †1F8AH                         | COMP0_TIME (H)   | COMP0_TIME (L)  |
| 1F88H                          | Reserved         | COMP0_CON       |
| †1F86H                         | EPA9_TIME (H)    | EPA9_TIME (L)   |
| 1F84H                          | Reserved         | EPA9_CON        |
| †1F82H                         | EPA8_TIME (H)    | EPA8_TIME (L)   |
| 1F80H                          | Reserved         | EPA8_CON        |

| EPA SFRs (Continued) |                 |                 |
|----------------------|-----------------|-----------------|
| Address              | High (Odd) Byte | Low (Even) Byte |
| †1F7EH               | EPA7_TIME (H)   | EPA7_TIME (L)   |
| 1F7CH                | Reserved        | EPA7_CON        |
| †1F7AH               | EPA6_TIME (H)   | EPA6_TIME (L)   |
| 1F78H                | Reserved        | EPA6_CON        |
| †1F76H               | EPA5_TIME (H)   | EPA5_TIME (L)   |
| 1F74H                | Reserved        | EPA5_CON        |
| †1F72H               | EPA4_TIME (H)   | EPA4_TIME (L)   |
| 1F70H                | Reserved        | EPA4_CON        |
| †1F6EH               | EPA3_TIME (H)   | EPA3_TIME (L)   |
| †1F6CH               | EPA3_CON (H)    | EPA3_CON (L)    |
| †1F6AH               | EPA2_TIME (H)   | EPA2_TIME (L)   |
| 1F68H                | Reserved        | EPA2_CON        |
| †1F66H               | EPA1_TIME (H)   | EPA1_TIME (L)   |
| †1F64H               | EPA1_CON (H)    | EPA1_CON (L)    |
| †1F62H               | EPA0_TIME (H)   | EPA0_TIME (L)   |
| 1F60H                | Reserved        | EPA0_CON        |
| J1850 SFRs (LB Only) |                 |                 |
| Address              | High (Odd) Byte | Low (Even) Byte |
| 1F5EH                | Reserved        | Reserved        |
| 1F5CH                | Reserved        | Reserved        |
| 1F5AH                | Reserved        | Reserved        |
| 1F58H                | Reserved        | <b>J_DLY</b>    |
| 1F56H                | Reserved        | Reserved        |
| 1F54H                | Reserved        | <b>J_CFG</b>    |
| 1F52H                | <b>J_STAT</b>   | <b>J_RX</b>     |
| 1F50H                | <b>J_CMD</b>    | <b>J_TX</b>     |

† Must be addressed as a word.

### 3.4 WINDOWING

Windowing maps a segment of higher memory (the upper register file or peripheral SFRs) into the lower register file. The window selection register (WSR) selects a 32-, 64- or 128-byte segment of higher memory to be windowed into the top of the lower register file space. Table 3-4 lists the WSR values for windowing the upper register file for both the 8XC196Lx and 8XC196Kx.

**Table 3-4. Windows**

| Base Address                               | WSR Value for 32-byte Window (00E0–00FFH) | WSR Value for 64-byte Window (00C0–00FFH) | WSR Value for 128-byte Window (0080–00FFH) |
|--|---|---|--|
| <b>Peripheral SFRs</b>                     |   |   |  |
| 1FE0H                                      | 7FH (Note)                                | 3FH (Note)                                | 1FH (Note)                                 |
| 1FC0H                                      | 7EH                                       |   |  |
| 1FA0H                                      | 7DH                                       | 3EH                                       | 1FH (Note)                                 |
| 1F80H                                      | 7CH                                       |   |  |
| 1F60H                                      | 7BH                                       | 3DH                                       | 1EH  |
| 1F40H                                      | 7AH                                       |   |  |
| 1F20H                                      | 79H                                       | 3CH                                       | 1EH  |
| 1F00H                                      | 78H                                       |   |  |
| <b>CAN Peripheral SFRs (87C196CA Only)</b> |   |   |  |
| 1EE0H                                      | 77H                                       | 3BH                                       | 1DH  |
| 1EC0H                                      | 76H                                       |   |  |
| 1EA0H                                      | 75H                                       | 3AH                                       | 1DH  |
| 1E80H                                      | 74H                                       |   |  |
| 1E60H                                      | 73H                                       | 39H                                       | 1CH  |
| 1E40H                                      | 72H                                       |   |  |
| 1E20H                                      | 71H                                       | 38H                                       | 1CH  |
| 1E00H                                      | 70H                                       |   |  |
| <b>Register RAM (87C196JV Only)</b>        |   |   |  |
| 1DE0H                                      | 6FH                                       | 37H                                       | 1BH  |
| 1DC0H                                      | 6EH                                       |   |  |
| 1DA0H                                      | 6DH                                       | 36H                                       | 1BH  |
| 1D80H                                      | 6CH                                       |   |  |
| 1D60H                                      | 6BH                                       | 35H                                       | 1AH  |
| 1D40H                                      | 6AH                                       |   |  |
| 1D20H                                      | 69H                                       | 34H                                       | 1AH  |
| 1D00H                                      | 68H                                       |   |  |

**NOTE:** Locations 1FE0–1FFFH contain memory-mapped SFRs that cannot be accessed through a window. Reading these locations through a window returns FFH; writing these locations through a window has no effect.

Table 3-4. Windows (Continued)

| Base Address  | WSR Value for 32-byte Window (00E0–00FFH) | WSR Value for 64-byte Window (00C0–00FFH) | WSR Value for 128-byte Window (0080–00FFH) |
|---|---|---|--|
| <b>Register RAM (87C196JV Only; Continued)</b>              |   |   |  |
| 1CE0H   | 67H                                       | 33H                                       | 19H  |
| 1CC0H   | 66H                                       |   |  |
| 1CA0H   | 65H                                       |   |  |
| 1C80H   | 64H                                       | 32H                                       | 18H  |
| 1C60H   | 63H                                       |   |  |
| 1C40H   | 62H                                       |   |  |
| 1C20H   | 61H                                       | 31H                                       | 18H  |
| 1C00H   | 60H                                       | 30H                                       |  |
| <b>Upper Register File (CA, JT, JV, KT)</b>                 |   |   |  |
| 03E0H   | 5FH                                       | 2FH                                       | 17H  |
| 03C0H   | 5EH                                       |   |  |
| 03A0H   | 5DH                                       |   |  |
| 0380H   | 5CH                                       | 2EH                                       | 16H  |
| 0360H   | 5BH                                       |   |  |
| 0340H   | 5AH                                       |   |  |
| 0320H   | 59H                                       | 2DH                                       | 16H  |
| 0300H   | 58H                                       | 2CH                                       |  |
| <b>Upper Register File (CA, JT, JV, KT, LA, LB)</b>         |   |   |  |
| 02E0H   | 57H                                       | 2BH                                       | 15H  |
| 02C0H   | 56H                                       |   |  |
| 02A0H   | 55H                                       |   |  |
| 0280H   | 54H                                       | 2AH                                       | 14H  |
| 0260H   | 53H                                       |   |  |
| 0240H   | 52H                                       |   |  |
| 0220H   | 51H                                       | 29H                                       | 14H  |
| 0200H   | 50H                                       | 28H                                       |  |
| <b>Upper Register File (CA, JR, JT, JV, KR, KT, LA, LB)</b> |   |   |  |
| 01E0H   | 4FH                                       | 27H                                       | 13H  |
| 01C0H   | 4EH                                       |   |  |
| 01A0H   | 4DH                                       |   |  |
| 0180H   | 4CH                                       | 26H                                       | 13H  |

**NOTE:** Locations 1FE0–1FFFH contain memory-mapped SFRs that cannot be accessed through a window. Reading these locations through a window returns FFH; writing these locations through a window has no effect.

Table 3-4. Windows (Continued)

| Base Address  | WSR Value for 32-byte Window (00E0–00FFH) | WSR Value for 64-byte Window (00C0–00FFH) | WSR Value for 128-byte Window (0080–00FFH) |
|---|---|---|--|
| <b>Upper Register File (CA, JR, JT, JV, KR, KT, LA, LB, LD)</b> |   |   |  |
| 0160H   | 4BH                                       | 25H                                       | 12H  |
| 0140H   | 4AH                                       |   |  |
| 0120H   | 49H                                       |   |  |
| 0100H   | 48H                                       | 24H                                       |  |

**NOTE:** Locations 1FE0–1FFFH contain memory-mapped SFRs that cannot be accessed through a window. Reading these locations through a window returns FFH; writing these locations through a window has no effect.



# **Standard and PTS Interrupts**



# CHAPTER 4

## STANDARD AND PTS INTERRUPTS

The interrupt structure of the 8XC196Lx is the same as that of the 8XC196Jx. The only difference is that the slave port interrupts (INT08:06) now support the J1850 controller peripheral.

### 4.1 INTERRUPT SOURCES, VECTORS, AND PRIORITIES

Table 4-1 lists the 8XC196Lx's interrupts sources, default priorities (30 is highest and 0 is lowest), and vector addresses.

[www.DataSheet4U.com](http://www.DataSheet4U.com) **Table 4-1. Interrupt Sources, Vectors, and Priorities**

| Interrupt Source   | Mnemonic           | Interrupt Controller Service |        |                       | PTS Service |        |          |
|--|--------------------|------------------------------|--------|-----------------------|-------------|--------|----------|
|  |                    | Name                         | Vector | Priority <sup>†</sup> | Name        | Vector | Priority |
| Nonmaskable Interrupt  | NMI <sup>†</sup>   | INT15                        | 203EH  | 30                    | —           | —      | —        |
| EXTINT Pin   | EXTINT             | INT14                        | 203CH  | 14                    | PTS14       | 205CH  | 29       |
| Reserved   | —                  | INT13                        | 203AH  | 13                    | PTS13       | 205AH  | 28       |
| SIO Receive  | RI                 | INT12                        | 2038H  | 12                    | PTS12       | 2058H  | 27       |
| SIO Transmit   | TI                 | INT11                        | 2036H  | 11                    | PTS11       | 2056H  | 26       |
| SSIO Channel 1 Transfer  | SSIO1              | INT10                        | 2034H  | 10                    | PTS10       | 2054H  | 25       |
| SSIO Channel 0 Transfer  | SSIO0              | INT09                        | 2032H  | 09                    | PTS09       | 2052H  | 24       |
| J1850 Status (LB only)   | J1850ST            | INT08                        | 2030H  | 08                    | PTS08       | 2050H  | 23       |
| Reserved (LA, LD)  | —                  | INT08                        | 2030H  | 08                    | PTS08       | 2050H  | 23       |
| Unimplemented Opcode   | —                  | —                            | 2012H  | —                     | —           | —      | —        |
| Software TRAP Instruction  | —                  | —                            | 2010H  | —                     | —           | —      | —        |
| J1850 Receive (LB only)  | J1850RX            | INT07                        | 200EH  | 07                    | PTS07       | 204EH  | 22       |
| Reserved (LA, LD)  | —                  | INT07                        | 200EH  | 07                    | PTS07       | 204EH  | 22       |
| J1850 Transmit (LB only)   | J1850TX            | INT06                        | 200CH  | 06                    | PTS06       | 204CH  | 21       |
| Reserved (LA, LD)  | —                  | INT06                        | 200CH  | 06                    | PTS06       | 204CH  | 21       |
| A/D Conv. Complete (LA, LB)  | AD_DONE            | INT05                        | 200AH  | 05                    | PTS05       | 204AH  | 20       |
| Reserved (LD)  | —                  | INT05                        | 200AH  | 05                    | PTS05       | 204AH  | 20       |
| EPA Capture/Compare 0  | EPA0               | INT04                        | 2008H  | 04                    | PTS04       | 2048H  | 19       |
| EPA Capture/Compare 1  | EPA1               | INT03                        | 2006H  | 03                    | PTS03       | 2046H  | 18       |
| EPA Capture/Compare 2  | EPA2               | INT02                        | 2004H  | 02                    | PTS02       | 2044H  | 17       |
| EPA Capture/Compare 3  | EPA3               | INT01                        | 2002H  | 01                    | PTS01       | 2042H  | 16       |
| EPA Capture/Compare 6–9,<br>EPA 0–3, 8–9 Overrun,<br>EPA Compare 0–1 <sup>†††</sup> ,<br>Timer 1 Overflow, &<br>Timer 2 Overflow | EPAx <sup>††</sup> | INT00                        | 2000H  | 00                    | PTS00       | 2040H  | 15       |

<sup>†</sup> The NMI pin is not bonded out on the 8XC196Lx. To protect against glitches, create a dummy interrupt service routine that contains a RET instruction.

<sup>††</sup> These interrupts are individually prioritized in the EPAIPV register. Read the EPA pending registers (EPA\_PEND and EPA\_PEND1) to determine which source caused the interrupt.

<sup>†††</sup> 87C196LA, LB only. The 83C196LD has no EPA compare-only channels.

## 4.2 INTERRUPT REGISTERS

This section describes the changes in the interrupt register bit definitions for the 8XC196Lx family.

### 4.2.1 Interrupt Mask Registers

Figures 4-1 and 4-2 illustrate the interrupt mask registers for the 8XC196Lx microcontrollers.

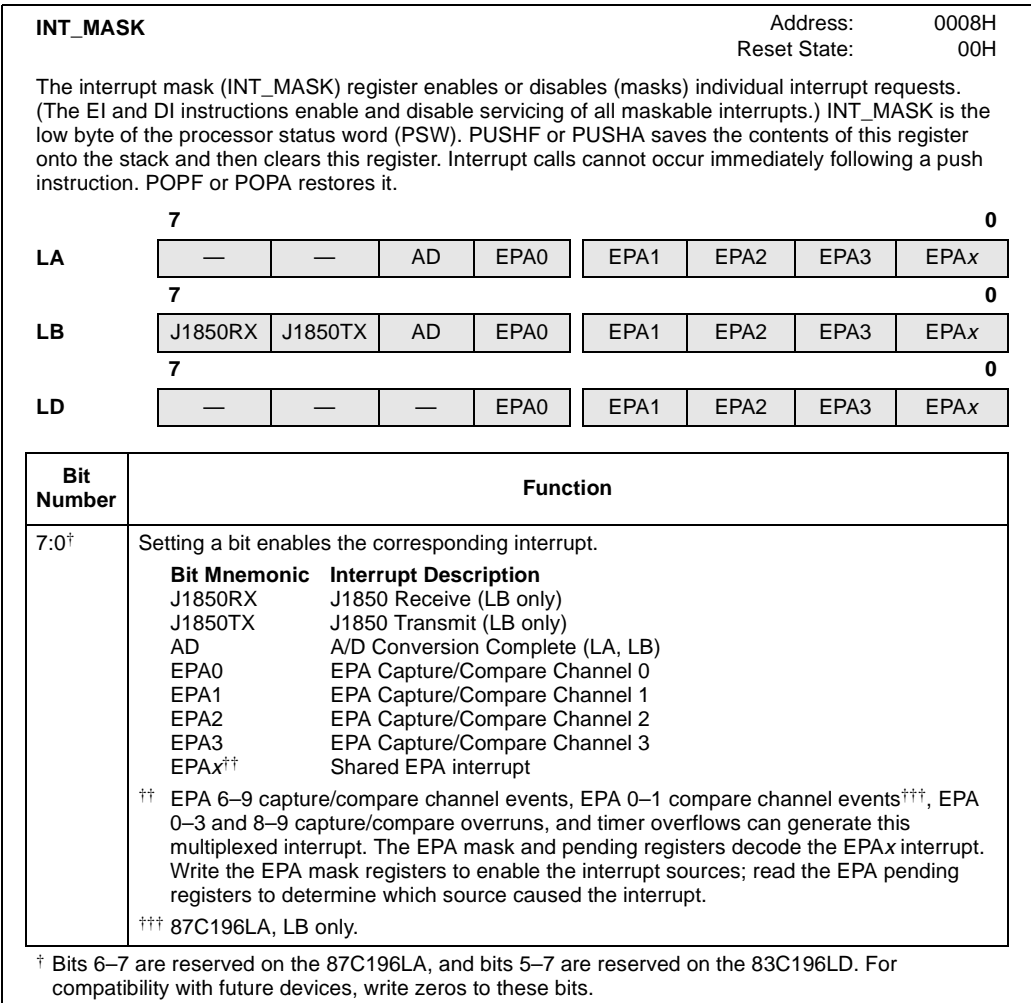

**Figure 4-1. Interrupt Mask (INT\_MASK) Register**

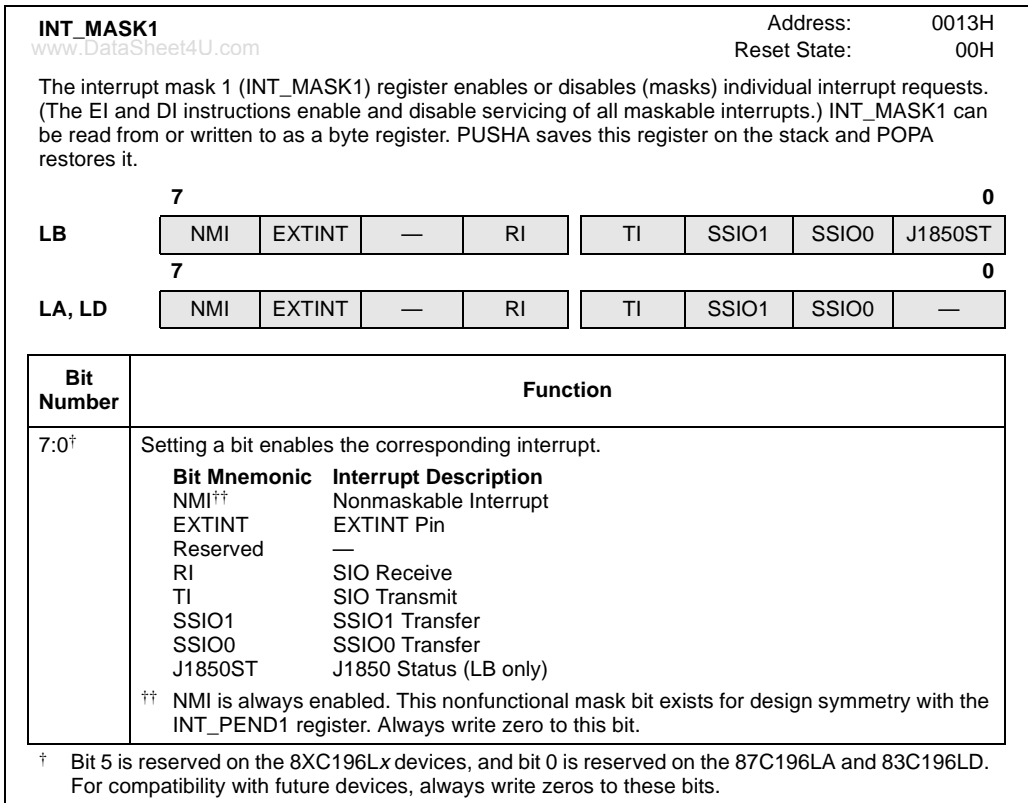

**Figure 4-2. Interrupt Mask 1 (INT\_MASK1) Register**

### 4.2.2 Interrupt Pending Registers

Figures 4-3 and 4-4 illustrate the interrupt pending registers for the 8XC196Lx microcontrollers.

|  |   |         |         |      |      |      |                  |      |                  |
|--|---|---------|---------|------|------|------|------------------|------|------------------|
| <b>INT_PEND</b><br><a href="http://www.DataSheet4U.com">www.DataSheet4U.com</a>  | Address: 0009H<br>Reset State: 00H  |         |         |      |      |      |                  |      |                  |
| <p>When hardware detects an interrupt request, it sets the corresponding bit in the interrupt pending (INT_PEND or INT_PEND1) registers. When the vector is taken, the hardware clears the pending bit. Software can generate an interrupt by setting the corresponding interrupt pending bit.</p> |   |         |         |      |      |      |                  |      |                  |
| 7  | 0   |         |         |      |      |      |                  |      |                  |
| LA   | <table border="1" style="width: 100%; border-collapse: collapse;"> <tr> <td style="width: 12.5%; text-align: center;">—</td> <td style="width: 12.5%; text-align: center;">—</td> <td style="width: 12.5%; text-align: center;">AD</td> <td style="width: 12.5%; text-align: center;">EPA0</td> <td style="width: 12.5%; text-align: center;">EPA1</td> <td style="width: 12.5%; text-align: center;">EPA2</td> <td style="width: 12.5%; text-align: center;">EPA3</td> <td style="width: 12.5%; text-align: center;">EPA<sub>x</sub></td> </tr> </table>             | —       | —       | AD   | EPA0 | EPA1 | EPA2             | EPA3 | EPA <sub>x</sub> |
| —  | —   | AD      | EPA0    | EPA1 | EPA2 | EPA3 | EPA <sub>x</sub> |      |                  |
| 7  | 0   |         |         |      |      |      |                  |      |                  |
| LB   | <table border="1" style="width: 100%; border-collapse: collapse;"> <tr> <td style="width: 12.5%; text-align: center;">J1850RX</td> <td style="width: 12.5%; text-align: center;">J1850TX</td> <td style="width: 12.5%; text-align: center;">AD</td> <td style="width: 12.5%; text-align: center;">EPA0</td> <td style="width: 12.5%; text-align: center;">EPA1</td> <td style="width: 12.5%; text-align: center;">EPA2</td> <td style="width: 12.5%; text-align: center;">EPA3</td> <td style="width: 12.5%; text-align: center;">EPA<sub>x</sub></td> </tr> </table> | J1850RX | J1850TX | AD   | EPA0 | EPA1 | EPA2             | EPA3 | EPA <sub>x</sub> |
| J1850RX  | J1850TX   | AD      | EPA0    | EPA1 | EPA2 | EPA3 | EPA <sub>x</sub> |      |                  |
| 7  | 0   |         |         |      |      |      |                  |      |                  |
| LD   | <table border="1" style="width: 100%; border-collapse: collapse;"> <tr> <td style="width: 12.5%; text-align: center;">—</td> <td style="width: 12.5%; text-align: center;">—</td> <td style="width: 12.5%; text-align: center;">—</td> <td style="width: 12.5%; text-align: center;">EPA0</td> <td style="width: 12.5%; text-align: center;">EPA1</td> <td style="width: 12.5%; text-align: center;">EPA2</td> <td style="width: 12.5%; text-align: center;">EPA3</td> <td style="width: 12.5%; text-align: center;">EPA<sub>x</sub></td> </tr> </table>              | —       | —       | —    | EPA0 | EPA1 | EPA2             | EPA3 | EPA <sub>x</sub> |
| —  | —   | —       | EPA0    | EPA1 | EPA2 | EPA3 | EPA <sub>x</sub> |      |                  |

| Bit Number                     | Function   |                     |                              |         |                         |         |                          |    |                                  |      |                               |      |                               |      |                               |      |                               |                                |                      |
|--------------------------------|--|---------------------|------------------------------|---------|-------------------------|---------|--------------------------|----|----------------------------------|------|-------------------------------|------|-------------------------------|------|-------------------------------|------|-------------------------------|--------------------------------|----------------------|
| 7:0 <sup>†</sup>               | <p>Any set bit indicates that the corresponding interrupt is pending. The interrupt bit is cleared when processing transfers to the corresponding interrupt vector.</p> <table border="0" style="width: 100%;"> <tr> <td style="width: 20%;"><b>Bit Mnemonic</b></td> <td><b>Interrupt Description</b></td> </tr> <tr> <td>J1850RX</td> <td>J1850 Receive (LB only)</td> </tr> <tr> <td>J1850TX</td> <td>J1850 Transmit (LB only)</td> </tr> <tr> <td>AD</td> <td>A/D Conversion Complete (LA, LB)</td> </tr> <tr> <td>EPA0</td> <td>EPA Capture/Compare Channel 0</td> </tr> <tr> <td>EPA1</td> <td>EPA Capture/Compare Channel 1</td> </tr> <tr> <td>EPA2</td> <td>EPA Capture/Compare Channel 2</td> </tr> <tr> <td>EPA3</td> <td>EPA Capture/Compare Channel 3</td> </tr> <tr> <td>EPA<sub>x</sub><sup>††</sup></td> <td>Shared EPA Interrupt</td> </tr> </table> <p><sup>††</sup> EPA 6–9 capture/compare channel events, EPA 0–1 compare channel events<sup>†††</sup>, EPA 0–3 and 8–9 capture/compare overruns, and timer overflows can generate this shared interrupt. Write the EPA mask registers to enable the interrupt sources; read the EPA pending registers to determine which source caused the interrupt.</p> <p><sup>†††</sup> 87C196LA, LB only.</p> | <b>Bit Mnemonic</b> | <b>Interrupt Description</b> | J1850RX | J1850 Receive (LB only) | J1850TX | J1850 Transmit (LB only) | AD | A/D Conversion Complete (LA, LB) | EPA0 | EPA Capture/Compare Channel 0 | EPA1 | EPA Capture/Compare Channel 1 | EPA2 | EPA Capture/Compare Channel 2 | EPA3 | EPA Capture/Compare Channel 3 | EPA <sub>x</sub> <sup>††</sup> | Shared EPA Interrupt |
| <b>Bit Mnemonic</b>            | <b>Interrupt Description</b>   |                     |                              |         |                         |         |                          |    |                                  |      |                               |      |                               |      |                               |      |                               |                                |                      |
| J1850RX                        | J1850 Receive (LB only)  |                     |                              |         |                         |         |                          |    |                                  |      |                               |      |                               |      |                               |      |                               |                                |                      |
| J1850TX                        | J1850 Transmit (LB only)   |                     |                              |         |                         |         |                          |    |                                  |      |                               |      |                               |      |                               |      |                               |                                |                      |
| AD                             | A/D Conversion Complete (LA, LB)   |                     |                              |         |                         |         |                          |    |                                  |      |                               |      |                               |      |                               |      |                               |                                |                      |
| EPA0                           | EPA Capture/Compare Channel 0  |                     |                              |         |                         |         |                          |    |                                  |      |                               |      |                               |      |                               |      |                               |                                |                      |
| EPA1                           | EPA Capture/Compare Channel 1  |                     |                              |         |                         |         |                          |    |                                  |      |                               |      |                               |      |                               |      |                               |                                |                      |
| EPA2                           | EPA Capture/Compare Channel 2  |                     |                              |         |                         |         |                          |    |                                  |      |                               |      |                               |      |                               |      |                               |                                |                      |
| EPA3                           | EPA Capture/Compare Channel 3  |                     |                              |         |                         |         |                          |    |                                  |      |                               |      |                               |      |                               |      |                               |                                |                      |
| EPA <sub>x</sub> <sup>††</sup> | Shared EPA Interrupt   |                     |                              |         |                         |         |                          |    |                                  |      |                               |      |                               |      |                               |      |                               |                                |                      |

<sup>†</sup> Bits 6–7 are reserved on the 87C196LA, and bits 5–7 are reserved on the 83C196LD. For compatibility with future devices, write zeros to these bits.

**Figure 4-3. Interrupt Pending (INT\_PEND) Register**

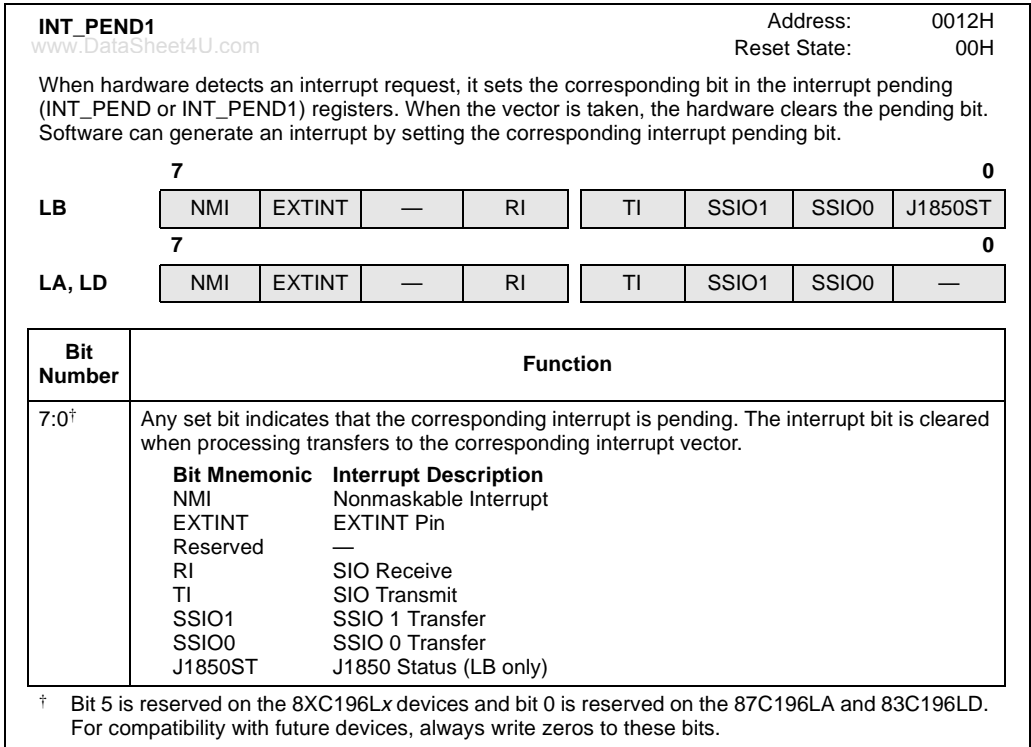

**Figure 4-4. Interrupt Pending 1 (INT\_PEND1) Register**

### 4.2.3 Peripheral Transaction Server Registers

Figures 4-5 and 4-6 illustrate the PTS interrupt select and service registers for the 8XC196Lx microcontrollers.



**PTSSSEL** Address: 0004H  
 www.DataSheet4U.com Reset State: 0000H

The PTS select (PTSSSEL) register selects either a PTS microcode routine or a standard interrupt service routine for each interrupt request. Setting a bit selects a PTS microcode routine; clearing a bit selects a standard interrupt service routine. In PTS modes that use the PTSCOUNT register, hardware clears the corresponding PTSSSEL bit when PTSCOUNT reaches zero. The end-of-PTS interrupt service routine must reset the PTSSSEL bit to re-enable the PTS channel.

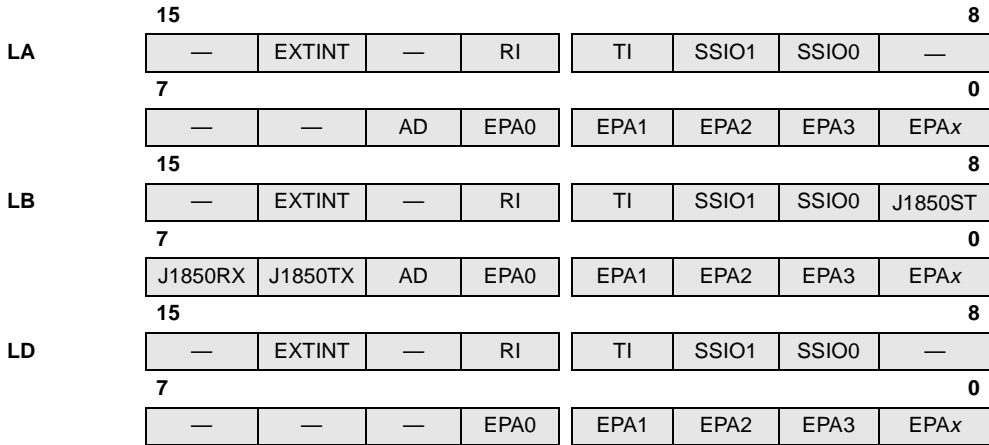

| Bit Number            | Function  |              |           |            |        |            |       |                       |   |       |    |             |       |    |              |       |       |                 |       |       |                 |       |              |              |       |             |               |       |             |                |       |             |                         |       |      |                               |       |      |                               |       |      |                               |       |      |                               |       |                    |                 |       |
|-----------------------|---|--------------|-----------|------------|--------|------------|-------|-----------------------|---|-------|----|-------------|-------|----|--------------|-------|-------|-----------------|-------|-------|-----------------|-------|--------------|--------------|-------|-------------|---------------|-------|-------------|----------------|-------|-------------|-------------------------|-------|------|-------------------------------|-------|------|-------------------------------|-------|------|-------------------------------|-------|------|-------------------------------|-------|--------------------|-----------------|-------|
| 14:0 <sup>†</sup>     | Setting a bit causes the corresponding interrupt to be handled by a PTS microcode routine. The PTS interrupt vector locations are as follows: <table border="1" style="margin-left: 20px;"> <thead> <tr> <th>Bit Mnemonic</th> <th>Interrupt</th> <th>PTS Vector</th> </tr> </thead> <tbody> <tr> <td>EXTINT</td> <td>EXTINT pin</td> <td>205CH</td> </tr> <tr> <td>Reserved<sup>†</sup></td> <td>—</td> <td>205AH</td> </tr> <tr> <td>RI</td> <td>SIO Receive</td> <td>2058H</td> </tr> <tr> <td>TI</td> <td>SIO Transmit</td> <td>2056H</td> </tr> <tr> <td>SSIO1</td> <td>SSIO 1 Transfer</td> <td>2054H</td> </tr> <tr> <td>SSIO0</td> <td>SSIO 0 Transfer</td> <td>2052H</td> </tr> <tr> <td>J1850ST (LB)</td> <td>J1850 Status</td> <td>2050H</td> </tr> <tr> <td>J1850RX(LB)</td> <td>J1850 Receive</td> <td>204EH</td> </tr> <tr> <td>J1850TX(LB)</td> <td>J1850 Transmit</td> <td>204CH</td> </tr> <tr> <td>AD (LA, LB)</td> <td>A/D Conversion Complete</td> <td>204AH</td> </tr> <tr> <td>EPA0</td> <td>EPA Capture/Compare Channel 0</td> <td>2048H</td> </tr> <tr> <td>EPA1</td> <td>EPA Capture/Compare Channel 1</td> <td>2046H</td> </tr> <tr> <td>EPA2</td> <td>EPA Capture/Compare Channel 2</td> <td>2044H</td> </tr> <tr> <td>EPA3</td> <td>EPA Capture/Compare Channel 3</td> <td>2042H</td> </tr> <tr> <td>EPAx<sup>††</sup></td> <td>Multiplexed EPA</td> <td>2040H</td> </tr> </tbody> </table> <p><sup>††</sup> PTS service is not useful for shared interrupts because the PTS cannot readily determine the source of these interrupts.</p> | Bit Mnemonic | Interrupt | PTS Vector | EXTINT | EXTINT pin | 205CH | Reserved <sup>†</sup> | — | 205AH | RI | SIO Receive | 2058H | TI | SIO Transmit | 2056H | SSIO1 | SSIO 1 Transfer | 2054H | SSIO0 | SSIO 0 Transfer | 2052H | J1850ST (LB) | J1850 Status | 2050H | J1850RX(LB) | J1850 Receive | 204EH | J1850TX(LB) | J1850 Transmit | 204CH | AD (LA, LB) | A/D Conversion Complete | 204AH | EPA0 | EPA Capture/Compare Channel 0 | 2048H | EPA1 | EPA Capture/Compare Channel 1 | 2046H | EPA2 | EPA Capture/Compare Channel 2 | 2044H | EPA3 | EPA Capture/Compare Channel 3 | 2042H | EPAx <sup>††</sup> | Multiplexed EPA | 2040H |
| Bit Mnemonic          | Interrupt   | PTS Vector   |           |            |        |            |       |                       |   |       |    |             |       |    |              |       |       |                 |       |       |                 |       |              |              |       |             |               |       |             |                |       |             |                         |       |      |                               |       |      |                               |       |      |                               |       |      |                               |       |                    |                 |       |
| EXTINT                | EXTINT pin  | 205CH        |           |            |        |            |       |                       |   |       |    |             |       |    |              |       |       |                 |       |       |                 |       |              |              |       |             |               |       |             |                |       |             |                         |       |      |                               |       |      |                               |       |      |                               |       |      |                               |       |                    |                 |       |
| Reserved <sup>†</sup> | —   | 205AH        |           |            |        |            |       |                       |   |       |    |             |       |    |              |       |       |                 |       |       |                 |       |              |              |       |             |               |       |             |                |       |             |                         |       |      |                               |       |      |                               |       |      |                               |       |      |                               |       |                    |                 |       |
| RI                    | SIO Receive   | 2058H        |           |            |        |            |       |                       |   |       |    |             |       |    |              |       |       |                 |       |       |                 |       |              |              |       |             |               |       |             |                |       |             |                         |       |      |                               |       |      |                               |       |      |                               |       |      |                               |       |                    |                 |       |
| TI                    | SIO Transmit  | 2056H        |           |            |        |            |       |                       |   |       |    |             |       |    |              |       |       |                 |       |       |                 |       |              |              |       |             |               |       |             |                |       |             |                         |       |      |                               |       |      |                               |       |      |                               |       |      |                               |       |                    |                 |       |
| SSIO1                 | SSIO 1 Transfer   | 2054H        |           |            |        |            |       |                       |   |       |    |             |       |    |              |       |       |                 |       |       |                 |       |              |              |       |             |               |       |             |                |       |             |                         |       |      |                               |       |      |                               |       |      |                               |       |      |                               |       |                    |                 |       |
| SSIO0                 | SSIO 0 Transfer   | 2052H        |           |            |        |            |       |                       |   |       |    |             |       |    |              |       |       |                 |       |       |                 |       |              |              |       |             |               |       |             |                |       |             |                         |       |      |                               |       |      |                               |       |      |                               |       |      |                               |       |                    |                 |       |
| J1850ST (LB)          | J1850 Status  | 2050H        |           |            |        |            |       |                       |   |       |    |             |       |    |              |       |       |                 |       |       |                 |       |              |              |       |             |               |       |             |                |       |             |                         |       |      |                               |       |      |                               |       |      |                               |       |      |                               |       |                    |                 |       |
| J1850RX(LB)           | J1850 Receive   | 204EH        |           |            |        |            |       |                       |   |       |    |             |       |    |              |       |       |                 |       |       |                 |       |              |              |       |             |               |       |             |                |       |             |                         |       |      |                               |       |      |                               |       |      |                               |       |      |                               |       |                    |                 |       |
| J1850TX(LB)           | J1850 Transmit  | 204CH        |           |            |        |            |       |                       |   |       |    |             |       |    |              |       |       |                 |       |       |                 |       |              |              |       |             |               |       |             |                |       |             |                         |       |      |                               |       |      |                               |       |      |                               |       |      |                               |       |                    |                 |       |
| AD (LA, LB)           | A/D Conversion Complete   | 204AH        |           |            |        |            |       |                       |   |       |    |             |       |    |              |       |       |                 |       |       |                 |       |              |              |       |             |               |       |             |                |       |             |                         |       |      |                               |       |      |                               |       |      |                               |       |      |                               |       |                    |                 |       |
| EPA0                  | EPA Capture/Compare Channel 0   | 2048H        |           |            |        |            |       |                       |   |       |    |             |       |    |              |       |       |                 |       |       |                 |       |              |              |       |             |               |       |             |                |       |             |                         |       |      |                               |       |      |                               |       |      |                               |       |      |                               |       |                    |                 |       |
| EPA1                  | EPA Capture/Compare Channel 1   | 2046H        |           |            |        |            |       |                       |   |       |    |             |       |    |              |       |       |                 |       |       |                 |       |              |              |       |             |               |       |             |                |       |             |                         |       |      |                               |       |      |                               |       |      |                               |       |      |                               |       |                    |                 |       |
| EPA2                  | EPA Capture/Compare Channel 2   | 2044H        |           |            |        |            |       |                       |   |       |    |             |       |    |              |       |       |                 |       |       |                 |       |              |              |       |             |               |       |             |                |       |             |                         |       |      |                               |       |      |                               |       |      |                               |       |      |                               |       |                    |                 |       |
| EPA3                  | EPA Capture/Compare Channel 3   | 2042H        |           |            |        |            |       |                       |   |       |    |             |       |    |              |       |       |                 |       |       |                 |       |              |              |       |             |               |       |             |                |       |             |                         |       |      |                               |       |      |                               |       |      |                               |       |      |                               |       |                    |                 |       |
| EPAx <sup>††</sup>    | Multiplexed EPA   | 2040H        |           |            |        |            |       |                       |   |       |    |             |       |    |              |       |       |                 |       |       |                 |       |              |              |       |             |               |       |             |                |       |             |                         |       |      |                               |       |      |                               |       |      |                               |       |      |                               |       |                    |                 |       |

<sup>†</sup> Bit 13 is reserved on the 8XC196Lx devices and bits 6–8 are reserved on the 87C196LA and 83C196LD. For compatibility with future devices, write zeros to these bits.

Figure 4-5. PTS Select (PTSSSEL) Register

**PTSSRV**

www.DataSheet4U.com

Address: 0006H

Reset State: 0000H

The PTS service (PTSSRV) register is used by the hardware to indicate that the final PTS interrupt has been serviced by the PTS routine. When PTSCOUNT reaches zero, hardware clears the corresponding PTSSSEL bit and sets the PTSSRV bit, which requests the end-of-PTS interrupt. When the end-of-PTS interrupt is called, hardware clears the PTSSRV bit. The end-of-PTS interrupt service routine must set the PTSSSEL bit to re-enable the PTS channel.

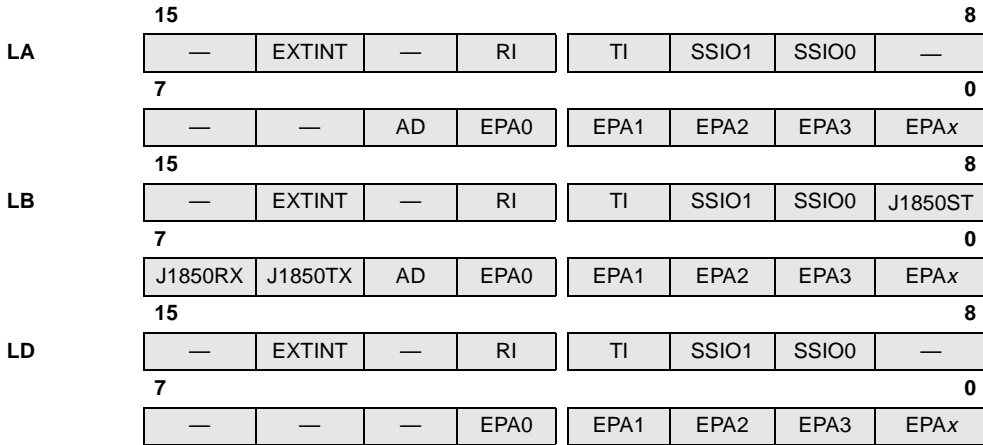

| Bits                           | Function  |                 |           |                 |        |            |       |                       |   |       |    |             |       |    |              |       |       |                 |       |       |                 |       |              |              |       |              |               |       |              |                |       |             |                         |       |      |                               |       |      |                               |       |      |                               |       |      |                               |       |                                |                 |       |
|--------------------------------|---|-----------------|-----------|-----------------|--------|------------|-------|-----------------------|---|-------|----|-------------|-------|----|--------------|-------|-------|-----------------|-------|-------|-----------------|-------|--------------|--------------|-------|--------------|---------------|-------|--------------|----------------|-------|-------------|-------------------------|-------|------|-------------------------------|-------|------|-------------------------------|-------|------|-------------------------------|-------|------|-------------------------------|-------|--------------------------------|-----------------|-------|
| 14:0 <sup>†</sup>              | <p>A bit is set by hardware to request an end-of-PTS interrupt for the corresponding interrupt through its standard interrupt vector.</p> <p>The standard interrupt vector locations are as follows:</p> <table border="1"> <thead> <tr> <th>Bit Mnemonic</th> <th>Interrupt</th> <th>Standard Vector</th> </tr> </thead> <tbody> <tr> <td>EXTINT</td> <td>EXTINT pin</td> <td>203CH</td> </tr> <tr> <td>Reserved<sup>†</sup></td> <td>—</td> <td>203AH</td> </tr> <tr> <td>RI</td> <td>SIO Receive</td> <td>2038H</td> </tr> <tr> <td>TI</td> <td>SIO Transmit</td> <td>2036H</td> </tr> <tr> <td>SSIO1</td> <td>SSIO 1 Transfer</td> <td>2034H</td> </tr> <tr> <td>SSIO0</td> <td>SSIO 0 Transfer</td> <td>2032H</td> </tr> <tr> <td>J1850ST (LB)</td> <td>J1850 Status</td> <td>2030H</td> </tr> <tr> <td>J1850RX (LB)</td> <td>J1850 Receive</td> <td>202EH</td> </tr> <tr> <td>J1850TX (LB)</td> <td>J1850 Transmit</td> <td>202CH</td> </tr> <tr> <td>AD (LA, LB)</td> <td>A/D Conversion Complete</td> <td>202AH</td> </tr> <tr> <td>EPA0</td> <td>EPA Capture/Compare Channel 0</td> <td>2028H</td> </tr> <tr> <td>EPA1</td> <td>EPA Capture/Compare Channel 1</td> <td>2026H</td> </tr> <tr> <td>EPA2</td> <td>EPA Capture/Compare Channel 2</td> <td>2024H</td> </tr> <tr> <td>EPA3</td> <td>EPA Capture/Compare Channel 3</td> <td>2022H</td> </tr> <tr> <td>EPA<sub>x</sub><sup>††</sup></td> <td>Multiplexed EPA</td> <td>2020H</td> </tr> </tbody> </table> <p><sup>††</sup> PTS service is not useful for shared interrupts because the PTS cannot readily determine the source of these interrupts.</p> | Bit Mnemonic    | Interrupt | Standard Vector | EXTINT | EXTINT pin | 203CH | Reserved <sup>†</sup> | — | 203AH | RI | SIO Receive | 2038H | TI | SIO Transmit | 2036H | SSIO1 | SSIO 1 Transfer | 2034H | SSIO0 | SSIO 0 Transfer | 2032H | J1850ST (LB) | J1850 Status | 2030H | J1850RX (LB) | J1850 Receive | 202EH | J1850TX (LB) | J1850 Transmit | 202CH | AD (LA, LB) | A/D Conversion Complete | 202AH | EPA0 | EPA Capture/Compare Channel 0 | 2028H | EPA1 | EPA Capture/Compare Channel 1 | 2026H | EPA2 | EPA Capture/Compare Channel 2 | 2024H | EPA3 | EPA Capture/Compare Channel 3 | 2022H | EPA <sub>x</sub> <sup>††</sup> | Multiplexed EPA | 2020H |
| Bit Mnemonic                   | Interrupt   | Standard Vector |           |                 |        |            |       |                       |   |       |    |             |       |    |              |       |       |                 |       |       |                 |       |              |              |       |              |               |       |              |                |       |             |                         |       |      |                               |       |      |                               |       |      |                               |       |      |                               |       |                                |                 |       |
| EXTINT                         | EXTINT pin  | 203CH           |           |                 |        |            |       |                       |   |       |    |             |       |    |              |       |       |                 |       |       |                 |       |              |              |       |              |               |       |              |                |       |             |                         |       |      |                               |       |      |                               |       |      |                               |       |      |                               |       |                                |                 |       |
| Reserved <sup>†</sup>          | —   | 203AH           |           |                 |        |            |       |                       |   |       |    |             |       |    |              |       |       |                 |       |       |                 |       |              |              |       |              |               |       |              |                |       |             |                         |       |      |                               |       |      |                               |       |      |                               |       |      |                               |       |                                |                 |       |
| RI                             | SIO Receive   | 2038H           |           |                 |        |            |       |                       |   |       |    |             |       |    |              |       |       |                 |       |       |                 |       |              |              |       |              |               |       |              |                |       |             |                         |       |      |                               |       |      |                               |       |      |                               |       |      |                               |       |                                |                 |       |
| TI                             | SIO Transmit  | 2036H           |           |                 |        |            |       |                       |   |       |    |             |       |    |              |       |       |                 |       |       |                 |       |              |              |       |              |               |       |              |                |       |             |                         |       |      |                               |       |      |                               |       |      |                               |       |      |                               |       |                                |                 |       |
| SSIO1                          | SSIO 1 Transfer   | 2034H           |           |                 |        |            |       |                       |   |       |    |             |       |    |              |       |       |                 |       |       |                 |       |              |              |       |              |               |       |              |                |       |             |                         |       |      |                               |       |      |                               |       |      |                               |       |      |                               |       |                                |                 |       |
| SSIO0                          | SSIO 0 Transfer   | 2032H           |           |                 |        |            |       |                       |   |       |    |             |       |    |              |       |       |                 |       |       |                 |       |              |              |       |              |               |       |              |                |       |             |                         |       |      |                               |       |      |                               |       |      |                               |       |      |                               |       |                                |                 |       |
| J1850ST (LB)                   | J1850 Status  | 2030H           |           |                 |        |            |       |                       |   |       |    |             |       |    |              |       |       |                 |       |       |                 |       |              |              |       |              |               |       |              |                |       |             |                         |       |      |                               |       |      |                               |       |      |                               |       |      |                               |       |                                |                 |       |
| J1850RX (LB)                   | J1850 Receive   | 202EH           |           |                 |        |            |       |                       |   |       |    |             |       |    |              |       |       |                 |       |       |                 |       |              |              |       |              |               |       |              |                |       |             |                         |       |      |                               |       |      |                               |       |      |                               |       |      |                               |       |                                |                 |       |
| J1850TX (LB)                   | J1850 Transmit  | 202CH           |           |                 |        |            |       |                       |   |       |    |             |       |    |              |       |       |                 |       |       |                 |       |              |              |       |              |               |       |              |                |       |             |                         |       |      |                               |       |      |                               |       |      |                               |       |      |                               |       |                                |                 |       |
| AD (LA, LB)                    | A/D Conversion Complete   | 202AH           |           |                 |        |            |       |                       |   |       |    |             |       |    |              |       |       |                 |       |       |                 |       |              |              |       |              |               |       |              |                |       |             |                         |       |      |                               |       |      |                               |       |      |                               |       |      |                               |       |                                |                 |       |
| EPA0                           | EPA Capture/Compare Channel 0   | 2028H           |           |                 |        |            |       |                       |   |       |    |             |       |    |              |       |       |                 |       |       |                 |       |              |              |       |              |               |       |              |                |       |             |                         |       |      |                               |       |      |                               |       |      |                               |       |      |                               |       |                                |                 |       |
| EPA1                           | EPA Capture/Compare Channel 1   | 2026H           |           |                 |        |            |       |                       |   |       |    |             |       |    |              |       |       |                 |       |       |                 |       |              |              |       |              |               |       |              |                |       |             |                         |       |      |                               |       |      |                               |       |      |                               |       |      |                               |       |                                |                 |       |
| EPA2                           | EPA Capture/Compare Channel 2   | 2024H           |           |                 |        |            |       |                       |   |       |    |             |       |    |              |       |       |                 |       |       |                 |       |              |              |       |              |               |       |              |                |       |             |                         |       |      |                               |       |      |                               |       |      |                               |       |      |                               |       |                                |                 |       |
| EPA3                           | EPA Capture/Compare Channel 3   | 2022H           |           |                 |        |            |       |                       |   |       |    |             |       |    |              |       |       |                 |       |       |                 |       |              |              |       |              |               |       |              |                |       |             |                         |       |      |                               |       |      |                               |       |      |                               |       |      |                               |       |                                |                 |       |
| EPA <sub>x</sub> <sup>††</sup> | Multiplexed EPA   | 2020H           |           |                 |        |            |       |                       |   |       |    |             |       |    |              |       |       |                 |       |       |                 |       |              |              |       |              |               |       |              |                |       |             |                         |       |      |                               |       |      |                               |       |      |                               |       |      |                               |       |                                |                 |       |

<sup>†</sup> Bit 13 is reserved on the 8XC196Lx devices and bits 6–8 are reserved on the 87C196LA and 83C196LD. For compatibility with future devices, write zeros to these bits.

**Figure 4-6. PTS Service (PTSSRV) Register**

# I/O Ports





# CHAPTER 5 I/O PORTS

The I/O ports of the 8XC196Lx are functionally identical to those of the 8XC196Jx. However, on the 87C196LA and LB, the reset state level of all 41 general-purpose I/O pins has changed from a weak logic “1” (wk1) to a weak logic “0” (wk0). This chapter outlines the differences between the 87C196LA, LB and the 8XC196Kx controllers.

## 5.1 I/O PORTS OVERVIEW

Table 5-1 provides an overview of the 8XC196Lx and 8XC196Kx I/O ports.

**Table 5-1. Microcontroller Ports**

| Port   | Pins                     | Type          | Configuration Options       | Associated Peripheral or System Function                        |
|--------|--------------------------|---------------|-----------------------------|---|
| Port 0 | 8 (Kx)<br>6 (CA, Jx, Lx) | Standard      | Input-only                  | A/D converter<br>(not supported on LD)                          |
| Port 1 | 8 (Kx)<br>4 (CA, Jx, Lx) | Standard      | Complementary<br>Open-drain | EPA and timers  |
| Port 2 | 8 (Kx)<br>6 (CA, Jx, Lx) | Standard      | Complementary<br>Open-drain | J1850 (LB only), SIO,<br>interrupts, bus control, clock<br>gen. |
| Port 3 | 8                        | Memory mapped | Complementary<br>Open-drain | Address/data bus  |
| Port 4 | 8                        | Memory mapped | Complementary<br>Open-drain | Address/data bus  |
| Port 5 | 8 (Kx)<br>3 (CA, Jx, Lx) | Memory mapped | Complementary<br>Open-drain | Bus control, slave port   |
| Port 6 | 8 (Kx)<br>6 (CA, Jx, Lx) | Standard      | Complementary<br>Open-drain | EPA, SSIO   |

## 5.2 INTERNAL STRUCTURE FOR PORTS 1, 2, 5, AND 6 (BIDIRECTIONAL PORTS)

Figure 5-1 shows the logic for driving the output transistors, Q1 and Q2. Consult the datasheet for specifications on the amount of current that each port can source or sink.

In I/O mode (selected by clearing a port mode register bit), the port data output and the port direction registers are input to the multiplexers. These signals combine to drive the gates of Q1 and Q2 so that the output is high, low, or high impedance.

In special-function mode (selected by setting a port mode register bit), SFDIR and SFDATA are input to the multiplexers. These signals combine to drive the gates of Q1 and Q2 so that the output is high, low, or high impedance. Special-function output signals clear SFDIR; special-function

input signals set SFDIR. Even if a pin is to be used in special-function mode, you must still initialize the pin as an input or output by writing to the port direction register.

Resistor R1 provides ESD protection for the pin. Input signals are buffered. The standard ports use Schmitt-triggered buffers for improved noise immunity. Port 5 uses a standard input buffer because of the high speeds required for bus control functions. The signals are latched into the port pin register sample latch and output onto the internal bus when the port pin register is read.

The falling edge of RESET# turns on transistor Q3, which remains on for about 300 ns, causing the pin to change rapidly to its reset state. The active-low level of RESET# turns on transistor Q4, which weakly holds the pin low. Q4 remains on, weakly holding the pin low, until your software writes to the port mode register.

#### NOTE

P2.7 is an exception. After reset, P2.7 carries the CLKOUT signal (half the crystal input frequency) rather than being held low. When CLKOUT is selected, it is always a complementary output.

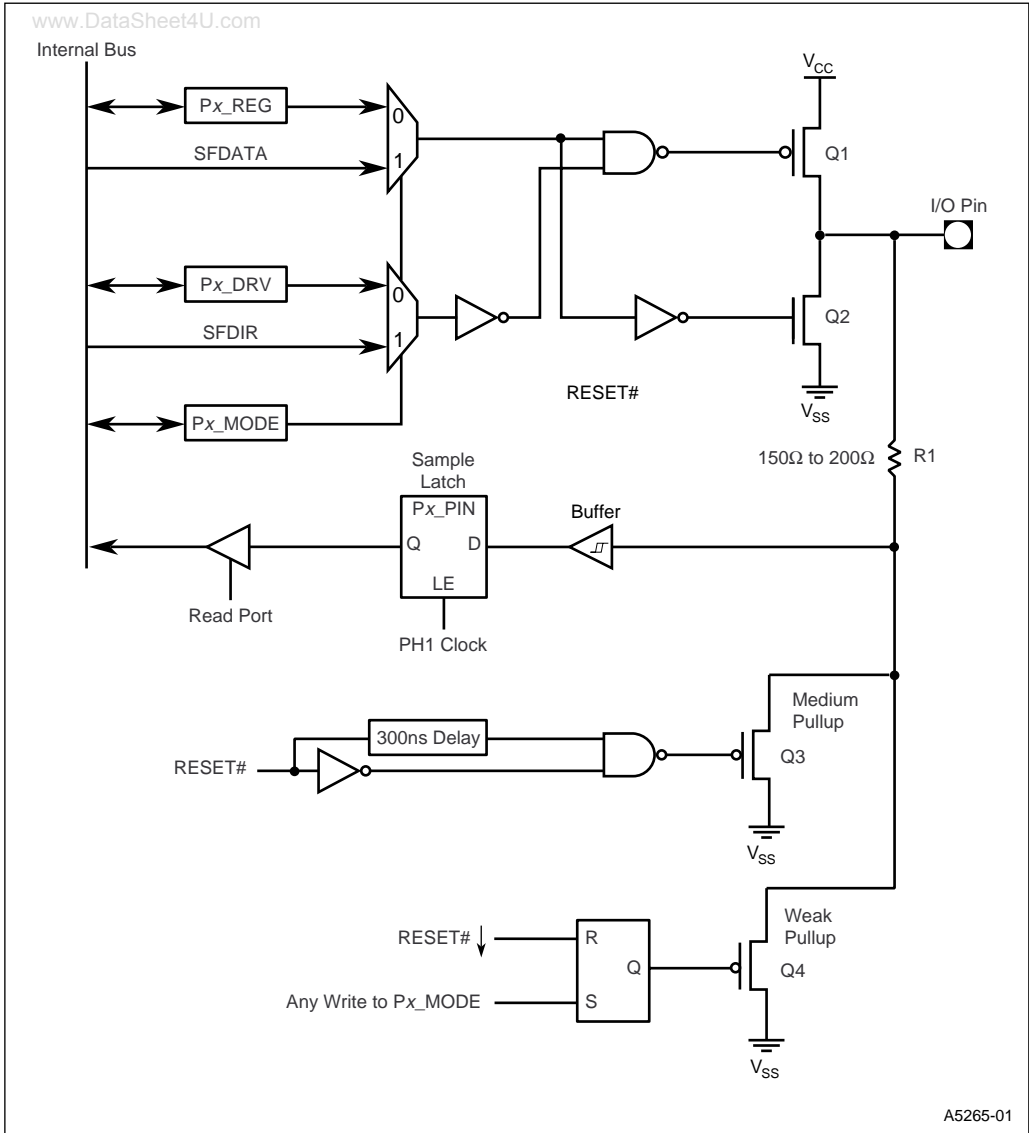

Figure 5-1. Ports 1, 2, 5, and 6 Internal Structure (87C196LA, LB Only)

### 5.2.1 Configuring Ports 1, 2, 5, and 6 (Bidirectional Ports)

Using the port mode register, you can individually configure each pin for port 1, 2, 5, and 6 to operate either as a general-purpose I/O signal (I/O mode) or as a special-function signal (special-function mode). In either mode, three configurations are possible: complementary output, high-

impedance input, or open-drain output. The port direction and data output registers select the configuration for each pin. Complementary output means that the microcontroller drives the signal high or low. High-impedance input means that the microcontroller floats the signal. Open-drain output means that the microcontroller drives the signal low or floats it. For I/O mode, the port data output register determines whether the microcontroller drives the signal high, drives it low, or floats it. For special-function mode, the on-chip peripheral or system function determines whether the microcontroller drives the signal high or low for complementary outputs.

The pins for ports 1, 2, 5, and 6 are weakly pulled low during and after reset. Initializing the pins by writing to the port mode register turns off the weak pull-downs. To ensure that the ports are initialized correctly, follow this suggested initialization sequence:

1. Write to Px\_DIR to configure the individual pins. Clearing a bit configures a pin as a complementary output. Setting a bit configures a pin as a high-impedance input or open-drain output.
2. Write to Px\_MODE to select either I/O or special-function mode. Writing to Px\_MODE (regardless of the value written) turns off the weak pull-downs. Even if the entire port is to be used as I/O (its default configuration after reset), **you must write to Px\_MODE to ensure that the weak pull-downs are turned off.**
3. Write to Px\_REG.

#### **For complementary output configurations:**

In I/O mode, write the data that is to be driven by the pins to the corresponding Px\_REG bits. In special-function mode, the value is immaterial because the on-chip peripheral or system function controls the pin. However, you must still write to Px\_REG to initialize the pin.

#### **For high-impedance input or open-drain output configurations:**

In I/O mode, write to Px\_REG to either float the pin, making it available as a high impedance input, or pull it low. Setting the corresponding Px\_REG bit floats the pin; clearing the corresponding Px\_REG bit pulls the pin low. In special-function mode, if the on-chip peripheral uses the pin as an input signal, you must set the corresponding Px\_REG bit so that the pin can be driven externally. If the on-chip peripheral uses the pin as an output signal, the value of the corresponding Px\_REG bit is immaterial because the on-chip peripheral or system function controls the pin. However, you must still write to Px\_REG to initialize the pin.

## **5.2.2 Special Bidirectional Port Considerations**

This section outlines special consideration for using the pins of ports 1, 2, 5, and 6.

1. After reset, your software must configure the device to match the external system. This accomplished by writing appropriate configuration data into Px\_MODE. Writing to Px\_MODE not only configures the pins but also turns off the transistor that weakly holds the pins low. For this reason, even if your port is to be used as it is configured at reset, you should still write data into Px\_MODE.
2. P2.6/TXJ1850 is the enable pin for ONCE mode. Because a high input during reset can cause the device to enter ONCE mode or a reserved test mode, caution must be exercised



in using this pin. Be certain that your system meets the  $V_{IH}$  specifications during reset to prevent inadvertent entry into ONCE mode or a test mode.

www.DataSheet4U.com

3. Following reset, P2.7/CLKOUT carries the strongly driven CLKOUT signal. It is not held low. When P2.7/CLKOUT is configured as CLKOUT, it is always a complementary output.

### 5.3 INTERNAL STRUCTURE FOR PORTS 3 AND 4 (ADDRESS/DATA BUS)

Figure 5-2 shows the logic of ports 3 and 4. Consult the datasheet for specifications on the amount of current ports 3 and 4 can source and sink.

During reset, the active-low level of RESET# turns off Q1 and Q2 and turns on transistor Q4, which weakly holds the pin low. Resistor R1 provides ESD protection for the pin. During normal operation, the device controls the port through BUS CONTROL SELECT, an internal control signal.

When the device needs to access external memory, it clears BUS CONTROL SELECT, selecting ADDRESS/DATA as the input to the multiplexer. ADDRESS/DATA then drives Q1 and Q2 as complementary outputs.

When external memory access is **not** required, the device sets BUS CONTROL SELECT, selecting P<sub>x</sub>\_REG as the input to the multiplexer. P<sub>x</sub>\_REG then drives Q1 and Q2. If P34\_DRV is set, Q1 and Q2 are driven as complementary outputs. If P34\_DRV is cleared, Q1 is disabled and Q2 is driven as an open-drain output requiring an external pull-up resistor. With the open-drain configuration (BUS CONTROL SELECT set and P34\_DRV cleared) and P<sub>x</sub>\_REG set, the pin can be used as an input. The signal on the pin is latched in the P<sub>x</sub>\_PIN register. The pins can be read, making it easy to see which pins are driven low by the device and which are driven high by external drivers while in open-drain mode.

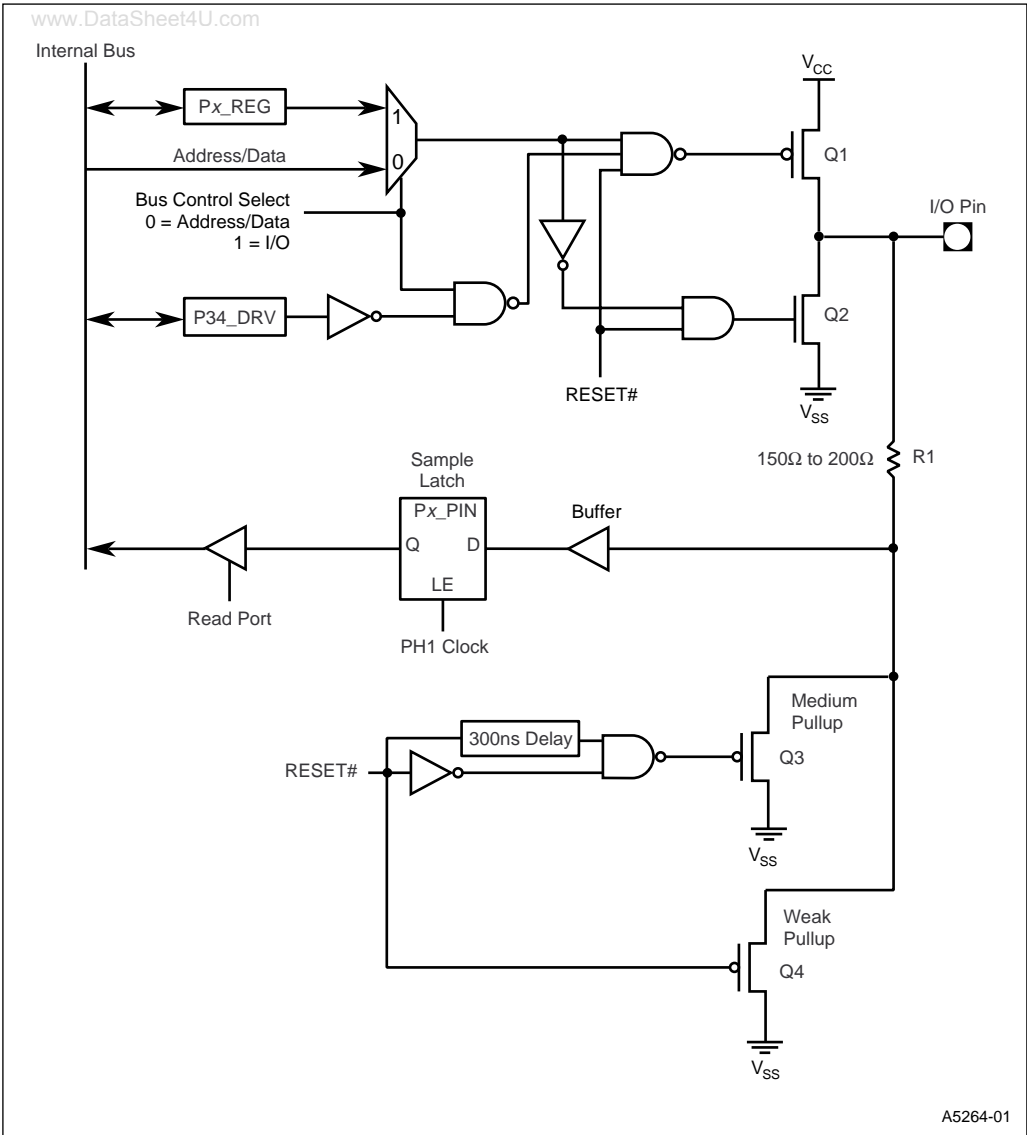

Figure 5-2. Ports 3 and 4 Internal Structure (87C196LA, LB Only)

# Synchronous Serial I/O Port



# CHAPTER 6

## SYNCHRONOUS SERIAL I/O PORT

The synchronous serial I/O (SSIO) port on the 8XC196Lx has been enhanced, implementing two new special function registers (SSIO\_CLK and SSIO1\_CLK) that allow you to select the operating mode and configure the phase and polarity of the serial clock signals.

### 6.1 SSIO 0 CLOCK REGISTER

The SSIO 0 clock (SSIO\_CLK) register selects the phase and polarity for the SC0 clock signal. In standard mode, SC0 is channel 0's clock signal. In duplex and channel-select modes, SC0 is the common clock signal for both SSIO channels.

|   |   |                  |
|---|---|------------------|
| <b>SSIO0_CLK</b>  |   | Address: 1FB5H   |
|   |   | Reset State: 00H |
| <p>The SSIO 0 clock (SSIO0_CLK) register configures the serial clock for channel 0. In standard mode, the SC0 is channel 0's clock signal. In duplex and channel-select modes, SC0 is the common clock signal for both SSIO channels.</p> |   |                  |
| 7   | 0 |                  |
| —   | — | PHAS POLS        |

| Bit Number | Bit Mnemonic | Function  |      |      |  |   |   |  |   |   |  |   |   |                                       |   |   |   |      |      |  |   |   |  |   |   |  |   |   |   |   |   |   |
|------------|--------------|---|------|------|--|---|---|--|---|---|--|---|---|---------------------------------------|---|---|---|------|------|--|---|---|--|---|---|--|---|---|---|---|---|---|
| 7:2        | —            | Reserved; for compatibility with future devices, write zeros to these bits.   |      |      |  |   |   |  |   |   |  |   |   |                                       |   |   |   |      |      |  |   |   |  |   |   |  |   |   |   |   |   |   |
| 1          | PHAS         | Phase and Polarity Select   |      |      |  |   |   |  |   |   |  |   |   |                                       |   |   |   |      |      |  |   |   |  |   |   |  |   |   |   |   |   |   |
| 0          | POLS         | <p>For normal transfers, these bits determine the idle state of the serial clock and select the serial clock signal edge on which the SSIO samples incoming data bits or shifts out outgoing data bits. These bits are ignored for handshaking transfers. Use SSIO0_CON to select the type of data transfer (normal or handshaking) for channel 0.</p> <p><b>For transmissions</b></p> <table style="width: 100%; border: none;"> <tr> <td style="width: 10%;">PHAS</td> <td style="width: 10%;">POLS</td> <td></td> </tr> <tr> <td>0</td> <td>0</td> <td>low idle state; shift on falling edges</td> </tr> <tr> <td>0</td> <td>1</td> <td>high idle state; shift on rising edges</td> </tr> <tr> <td>1</td> <td>0</td> <td>low idle state; shift on rising edges</td> </tr> <tr> <td>1</td> <td>1</td> <td>high idle state; shift on falling edges</td> </tr> </table> <p><b>For receptions</b></p> <table style="width: 100%; border: none;"> <tr> <td style="width: 10%;">PHAS</td> <td style="width: 10%;">POLS</td> <td></td> </tr> <tr> <td>0</td> <td>0</td> <td>low idle state; sample on rising edges</td> </tr> <tr> <td>0</td> <td>1</td> <td>high idle state; sample on falling edges</td> </tr> <tr> <td>1</td> <td>0</td> <td>low idle state; sample on falling edges</td> </tr> <tr> <td>1</td> <td>1</td> <td>high idle state; sample on rising edges</td> </tr> </table> | PHAS | POLS |  | 0 | 0 | low idle state; shift on falling edges | 0 | 1 | high idle state; shift on rising edges | 1 | 0 | low idle state; shift on rising edges | 1 | 1 | high idle state; shift on falling edges | PHAS | POLS |  | 0 | 0 | low idle state; sample on rising edges | 0 | 1 | high idle state; sample on falling edges | 1 | 0 | low idle state; sample on falling edges | 1 | 1 | high idle state; sample on rising edges |
| PHAS       | POLS         |   |      |      |  |   |   |  |   |   |  |   |   |                                       |   |   |   |      |      |  |   |   |  |   |   |  |   |   |   |   |   |   |
| 0          | 0            | low idle state; shift on falling edges  |      |      |  |   |   |  |   |   |  |   |   |                                       |   |   |   |      |      |  |   |   |  |   |   |  |   |   |   |   |   |   |
| 0          | 1            | high idle state; shift on rising edges  |      |      |  |   |   |  |   |   |  |   |   |                                       |   |   |   |      |      |  |   |   |  |   |   |  |   |   |   |   |   |   |
| 1          | 0            | low idle state; shift on rising edges   |      |      |  |   |   |  |   |   |  |   |   |                                       |   |   |   |      |      |  |   |   |  |   |   |  |   |   |   |   |   |   |
| 1          | 1            | high idle state; shift on falling edges   |      |      |  |   |   |  |   |   |  |   |   |                                       |   |   |   |      |      |  |   |   |  |   |   |  |   |   |   |   |   |   |
| PHAS       | POLS         |   |      |      |  |   |   |  |   |   |  |   |   |                                       |   |   |   |      |      |  |   |   |  |   |   |  |   |   |   |   |   |   |
| 0          | 0            | low idle state; sample on rising edges  |      |      |  |   |   |  |   |   |  |   |   |                                       |   |   |   |      |      |  |   |   |  |   |   |  |   |   |   |   |   |   |
| 0          | 1            | high idle state; sample on falling edges  |      |      |  |   |   |  |   |   |  |   |   |                                       |   |   |   |      |      |  |   |   |  |   |   |  |   |   |   |   |   |   |
| 1          | 0            | low idle state; sample on falling edges   |      |      |  |   |   |  |   |   |  |   |   |                                       |   |   |   |      |      |  |   |   |  |   |   |  |   |   |   |   |   |   |
| 1          | 1            | high idle state; sample on rising edges   |      |      |  |   |   |  |   |   |  |   |   |                                       |   |   |   |      |      |  |   |   |  |   |   |  |   |   |   |   |   |   |

**Figure 6-1. SSIO 0 Clock (SSIO0\_CLK) Register**

For transmissions, SSIO0\_CLK determines whether the SSIO shifts out data bits on rising or falling clock edges. For receptions, SSIO0\_CLK determines whether the SSIO samples data bits on rising or falling clock edges.

### 6.2 SSIO 1 CLOCK REGISTER

SSIO1\_CLK selects the SSIO mode of operation (standard, duplex, or channel-select), enables the channel-select master contention interrupt request, and selects the phase and polarity for the serial clock (SC1) for channels. In standard mode, use this register to configure the serial clock for channel 1.

| <b>SSIO1_CLK</b>  |              | Address: 1FB7H<br>Reset State: 00H   |               |     |  |   |   |               |   |   |             |   |   |   |   |   |   |
|---|--------------|--|---------------|-----|--|---|---|---------------|---|---|-------------|---|---|---|---|---|---|
| <p>The SSIO 1 clock (SSIO1_CLK) register selects the SSIO mode of operation (standard, duplex, or channel-select), enables the channel-select master contention interrupt request, and selects the phase and polarity for the serial clock (SC1) for channel 1.</p> |              |  |               |     |  |   |   |               |   |   |             |   |   |   |   |   |   |
| 7   | 0            |  |               |     |  |   |   |               |   |   |             |   |   |   |   |   |   |
| —   | —            | CHS    DUP    CONINT    CONPND    PHAS    POLS   |               |     |  |   |   |               |   |   |             |   |   |   |   |   |   |
| Bit Number  | Bit Mnemonic | Function   |               |     |  |   |   |               |   |   |             |   |   |   |   |   |   |
| 7:6   | —            | Reserved; for compatibility with future devices, write zeros to these bits.  |               |     |  |   |   |               |   |   |             |   |   |   |   |   |   |
| 5   | CHS          | These bits determine the SSIO operating mode.<br><table style="margin-left: 20px; border-collapse: collapse;"> <tr> <th style="padding: 2px;">CHS</th> <th style="padding: 2px;">DUP</th> <th style="padding: 2px;"></th> </tr> <tr> <td style="padding: 2px;">0</td> <td style="padding: 2px;">0</td> <td style="padding: 2px;">standard mode</td> </tr> <tr> <td style="padding: 2px;">0</td> <td style="padding: 2px;">1</td> <td style="padding: 2px;">duplex mode</td> </tr> <tr> <td style="padding: 2px;">1</td> <td style="padding: 2px;">0</td> <td style="padding: 2px;">channel-select half-duplex mode (uses SD1 only)</td> </tr> <tr> <td style="padding: 2px;">1</td> <td style="padding: 2px;">1</td> <td style="padding: 2px;">channel-select full-duplex mode (uses both SD0 and SD1)</td> </tr> </table> | CHS           | DUP |  | 0 | 0 | standard mode | 0 | 1 | duplex mode | 1 | 0 | channel-select half-duplex mode (uses SD1 only) | 1 | 1 | channel-select full-duplex mode (uses both SD0 and SD1) |
| CHS   | DUP          |  |               |     |  |   |   |               |   |   |             |   |   |   |   |   |   |
| 0   | 0            |  | standard mode |     |  |   |   |               |   |   |             |   |   |   |   |   |   |
| 0   | 1            |  | duplex mode   |     |  |   |   |               |   |   |             |   |   |   |   |   |   |
| 1   | 0            | channel-select half-duplex mode (uses SD1 only)  |               |     |  |   |   |               |   |   |             |   |   |   |   |   |   |
| 1   | 1            | channel-select full-duplex mode (uses both SD0 and SD1)  |               |     |  |   |   |               |   |   |             |   |   |   |   |   |   |
| 4   | DUP          |  |               |     |  |   |   |               |   |   |             |   |   |   |   |   |   |
| 3   | CONINT       | Master Contention Interrupt<br>For channel-select master operations, the SSIO sets the master contention interrupt pending bit (CONPND) when the CHS# pin is externally activated. In a system with multiple masters, an external master activates the CHS# signal to request control of the serial clock. CONINT determines whether the SSIO sets both CONPND and the SSIO0 interrupt pending bit or only CONPND when the CHS# pin is externally activated.<br>0 = SSIO sets only CONPND<br>1 = SSIO sets both CONPND and the SSIO0 interrupt pending bit<br>This bit is valid for channel-select master operations and ignored for all other operations.   |               |     |  |   |   |               |   |   |             |   |   |   |   |   |   |

**Figure 6-2. SSIO 1 Clock (SSIO1\_CLK) Register**

|   |   |                  |
|---|---|------------------|
| <b>SSIO1_CLK (Continued)</b>  |   | Address: 1FB7H   |
| <a href="http://www.DataSheet4U.com">www.DataSheet4U.com</a>  |   | Reset State: 00H |
| <p>The SSIO 1 clock (SSIO1_CLK) register selects the SSIO mode of operation (standard, duplex, or channel-select), enables the channel-select master contention interrupt request, and selects the phase and polarity for the serial clock (SC1) for channel 1.</p> |   |                  |
| 7   | 0 |                  |
| —   | — | CHS              |
| —   | — | CONINT           |
| —   | — | CONPND           |
| —   | — | PHAS             |
| —   | — | POLS             |

| Bit Number | Bit Mnemonic | Function  |      |      |  |   |   |  |   |   |  |   |   |                                       |   |   |   |      |      |  |   |   |  |   |   |  |   |   |   |   |   |   |
|------------|--------------|---|------|------|--|---|---|--|---|---|--|---|---|---------------------------------------|---|---|---|------|------|--|---|---|--|---|---|--|---|---|---|---|---|---|
| 2          | CONPND       | <p>Master Contention Interrupt Pending</p> <p>For channel-select master operations, the SSIO sets this bit when the CHS# pin is externally activated. In a system with multiple masters, an external master activates the CHS# signal to request control of the serial clock.</p> <p>This bit is valid for channel-select master operations and ignored for all other operations.</p>   |      |      |  |   |   |  |   |   |  |   |   |                                       |   |   |   |      |      |  |   |   |  |   |   |  |   |   |   |   |   |   |
| 1          | PHAS         | Phase and Polarity Select   |      |      |  |   |   |  |   |   |  |   |   |                                       |   |   |   |      |      |  |   |   |  |   |   |  |   |   |   |   |   |   |
| 0          | POLS         | <p>For normal transfers, these bits determine the idle state of the serial clock and select the serial clock signal edge that the SSIO samples incoming data bits or shifts out outgoing data bits.</p> <p><b>For transmissions</b></p> <table style="width: 100%; border-collapse: collapse;"> <tr> <td style="padding: 2px 10px 2px 10px;">PHAS</td> <td style="padding: 2px 10px 2px 10px;">POLS</td> <td style="padding: 2px 10px 2px 10px;"></td> </tr> <tr> <td style="padding: 2px 10px 2px 10px;">0</td> <td style="padding: 2px 10px 2px 10px;">0</td> <td style="padding: 2px 10px 2px 10px;">low idle state; shift on falling edges</td> </tr> <tr> <td style="padding: 2px 10px 2px 10px;">0</td> <td style="padding: 2px 10px 2px 10px;">1</td> <td style="padding: 2px 10px 2px 10px;">high idle state; shift on rising edges</td> </tr> <tr> <td style="padding: 2px 10px 2px 10px;">1</td> <td style="padding: 2px 10px 2px 10px;">0</td> <td style="padding: 2px 10px 2px 10px;">low idle state; shift on rising edges</td> </tr> <tr> <td style="padding: 2px 10px 2px 10px;">1</td> <td style="padding: 2px 10px 2px 10px;">1</td> <td style="padding: 2px 10px 2px 10px;">high idle state; shift on falling edges</td> </tr> </table> <p><b>For receptions</b></p> <table style="width: 100%; border-collapse: collapse;"> <tr> <td style="padding: 2px 10px 2px 10px;">PHAS</td> <td style="padding: 2px 10px 2px 10px;">POLS</td> <td style="padding: 2px 10px 2px 10px;"></td> </tr> <tr> <td style="padding: 2px 10px 2px 10px;">0</td> <td style="padding: 2px 10px 2px 10px;">0</td> <td style="padding: 2px 10px 2px 10px;">low idle state; sample on rising edges</td> </tr> <tr> <td style="padding: 2px 10px 2px 10px;">0</td> <td style="padding: 2px 10px 2px 10px;">1</td> <td style="padding: 2px 10px 2px 10px;">high idle state; sample on falling edges</td> </tr> <tr> <td style="padding: 2px 10px 2px 10px;">1</td> <td style="padding: 2px 10px 2px 10px;">0</td> <td style="padding: 2px 10px 2px 10px;">low idle state; sample on falling edges</td> </tr> <tr> <td style="padding: 2px 10px 2px 10px;">1</td> <td style="padding: 2px 10px 2px 10px;">1</td> <td style="padding: 2px 10px 2px 10px;">high idle state; sample on rising edges</td> </tr> </table> <p>These bits are ignored for duplex and channel-select modes; these modes use SC0 as the common clock signal. The SSIO0_CLK register contains the phase and polarity select bits for the SC0 clock signal.</p> <p>These bits are also ignored for handshaking transfers. Use SSIO1_CON to select the type of data transfer (normal or handshaking) for channel 1.</p> | PHAS | POLS |  | 0 | 0 | low idle state; shift on falling edges | 0 | 1 | high idle state; shift on rising edges | 1 | 0 | low idle state; shift on rising edges | 1 | 1 | high idle state; shift on falling edges | PHAS | POLS |  | 0 | 0 | low idle state; sample on rising edges | 0 | 1 | high idle state; sample on falling edges | 1 | 0 | low idle state; sample on falling edges | 1 | 1 | high idle state; sample on rising edges |
| PHAS       | POLS         |   |      |      |  |   |   |  |   |   |  |   |   |                                       |   |   |   |      |      |  |   |   |  |   |   |  |   |   |   |   |   |   |
| 0          | 0            | low idle state; shift on falling edges  |      |      |  |   |   |  |   |   |  |   |   |                                       |   |   |   |      |      |  |   |   |  |   |   |  |   |   |   |   |   |   |
| 0          | 1            | high idle state; shift on rising edges  |      |      |  |   |   |  |   |   |  |   |   |                                       |   |   |   |      |      |  |   |   |  |   |   |  |   |   |   |   |   |   |
| 1          | 0            | low idle state; shift on rising edges   |      |      |  |   |   |  |   |   |  |   |   |                                       |   |   |   |      |      |  |   |   |  |   |   |  |   |   |   |   |   |   |
| 1          | 1            | high idle state; shift on falling edges   |      |      |  |   |   |  |   |   |  |   |   |                                       |   |   |   |      |      |  |   |   |  |   |   |  |   |   |   |   |   |   |
| PHAS       | POLS         |   |      |      |  |   |   |  |   |   |  |   |   |                                       |   |   |   |      |      |  |   |   |  |   |   |  |   |   |   |   |   |   |
| 0          | 0            | low idle state; sample on rising edges  |      |      |  |   |   |  |   |   |  |   |   |                                       |   |   |   |      |      |  |   |   |  |   |   |  |   |   |   |   |   |   |
| 0          | 1            | high idle state; sample on falling edges  |      |      |  |   |   |  |   |   |  |   |   |                                       |   |   |   |      |      |  |   |   |  |   |   |  |   |   |   |   |   |   |
| 1          | 0            | low idle state; sample on falling edges   |      |      |  |   |   |  |   |   |  |   |   |                                       |   |   |   |      |      |  |   |   |  |   |   |  |   |   |   |   |   |   |
| 1          | 1            | high idle state; sample on rising edges   |      |      |  |   |   |  |   |   |  |   |   |                                       |   |   |   |      |      |  |   |   |  |   |   |  |   |   |   |   |   |   |

**Figure 6-2. SSIO 1 Clock (SSIO1\_CLK) Register (Continued)**

For transmissions, SSIO1\_CLK determines whether the SSIO shifts out data bits on rising or falling clock edges. For receptions, SSIO1\_CLK determines whether the SSIO samples data bits on the rising or falling clock edges.





# **Event Processor Array**



# CHAPTER 7

## EVENT PROCESSOR ARRAY

The EPA on the 8XC196Lx is functionally identical to that of the 8XC196Jx; however, the 8XC196Lx has only two capture/compare channels without pins instead of four. In addition, the 83C196LD has no compare-only channels.

### 7.1 EPA FUNCTIONAL OVERVIEW

Table 7-1 lists the capture/compare (with and without pins) and compare-only channels for each device in the 8XC196Lx and 8XC196Kx families.

**Table 7-1. EPA Channels**

| Device             | Capture/Compare Channels With Pins | Capture/Compare Channels Without Pins | Compare-only Channels |
|--------------------|------------------------------------|---------------------------------------|-----------------------|
| 8XC196LA, LB       | EPA3:0 and EPA9:8                  | EPA7:6                                | COMP1:0               |
| 8XC196LD           | EPA3:0 and EPA9:8                  | EPA7:6                                | —                     |
| 87C196CA, 8XC196Jx | EPA3:0 and EPA9:8                  | EPA7:4                                | COMP1:0               |
| 8XC196Kx           | EPA9:0                             | —                                     | COMP1:0               |

The 8XC196Lx's EPA performs input and output functions associated with two timer/counters, timer 1 and timer 2, as depicted in Figures 7-1 and 7-2.



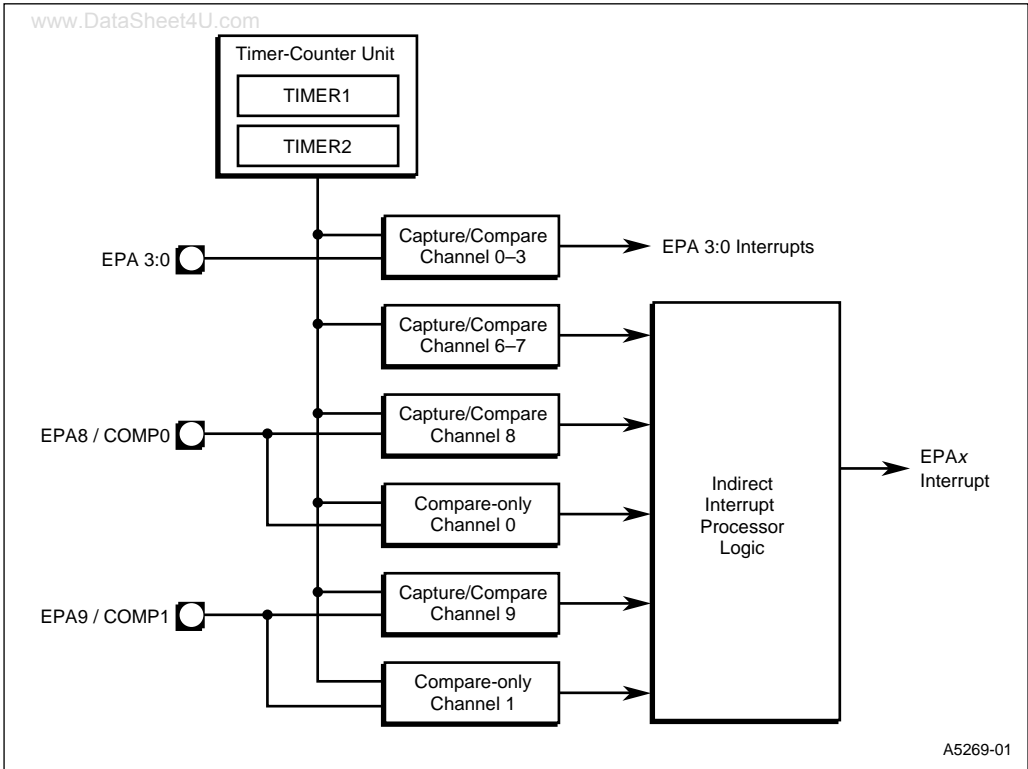

Figure 7-1. EPA Block Diagram (87C196LA, LB Only)

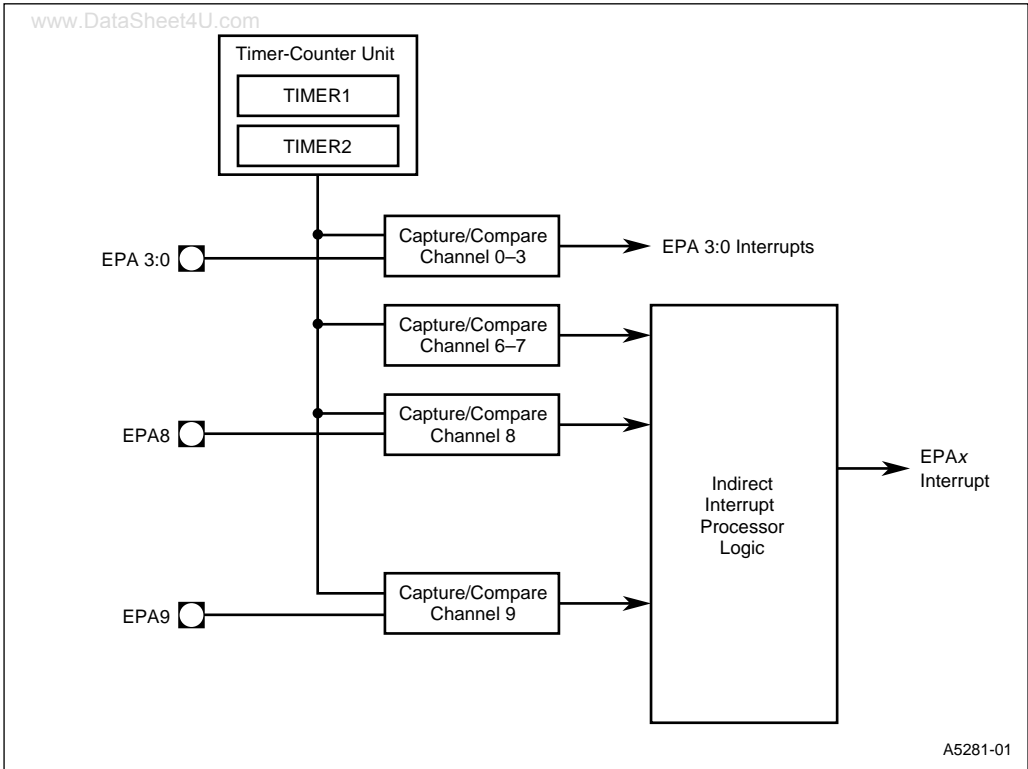
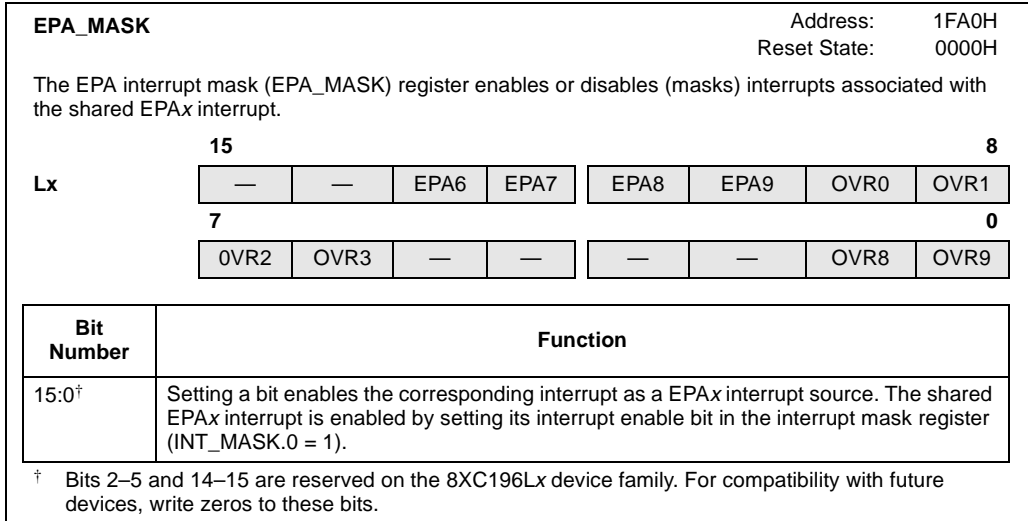

Figure 7-2. EPA Block Diagram (83C196LD Only)

### 7.1.1 EPA Mask Registers

Figures 7-3 and 7-4 illustrate the EPA mask registers, EPA\_MASK and EPA\_MASK1, for the 8XC196Lx microcontroller family.



**Figure 7-3. EPA Interrupt Mask (EPA\_MASK) Register**

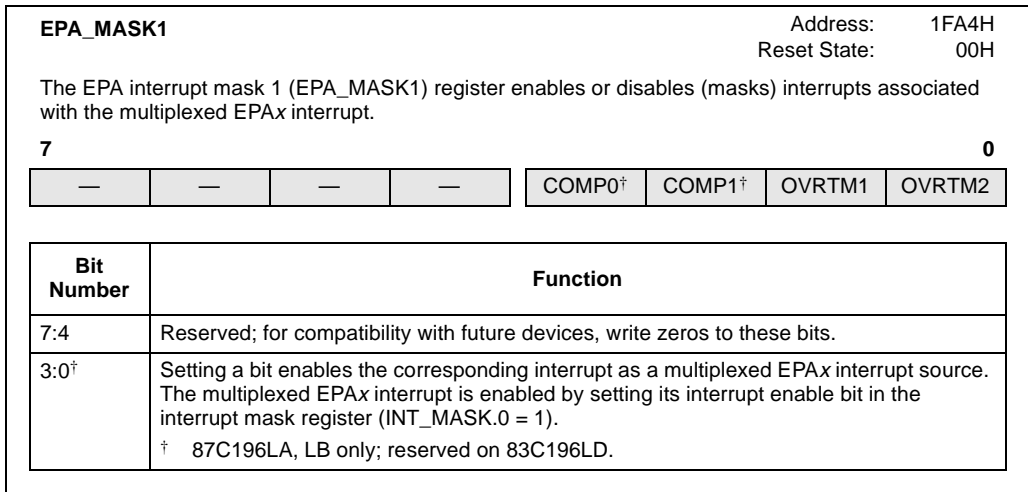

**Figure 7-4. EPA Interrupt Mask 1 (EPA\_MASK1) Register**

### 7.1.2 EPA Pending Registers

Figures 7-5 and 7-6 illustrate the EPA pending registers, EPA\_PEND and EPA\_PEND1, for the 8XC196Lx microcontroller family.

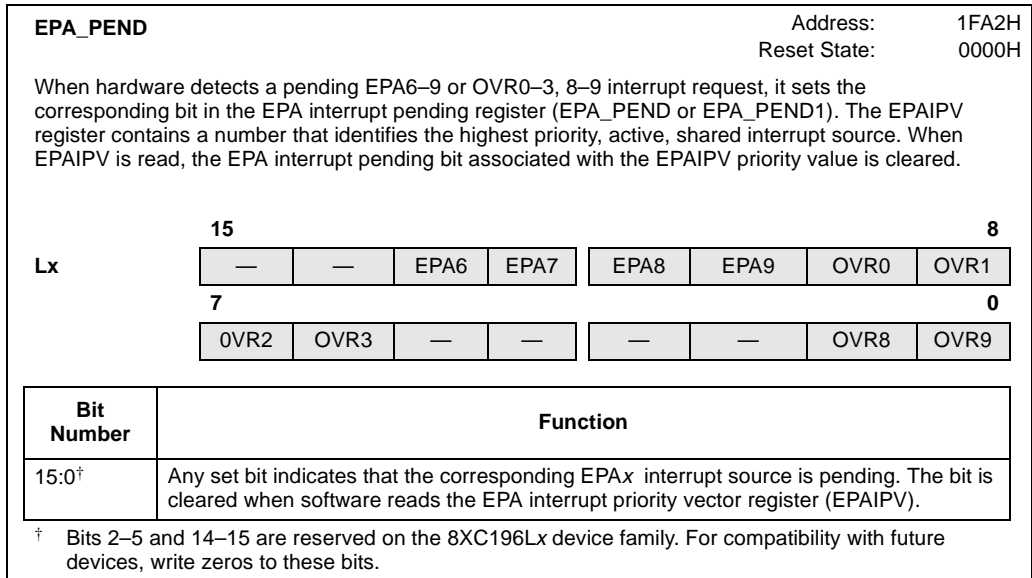

**Figure 7-5. EPA Interrupt Pending (EPA\_PEND) Register**

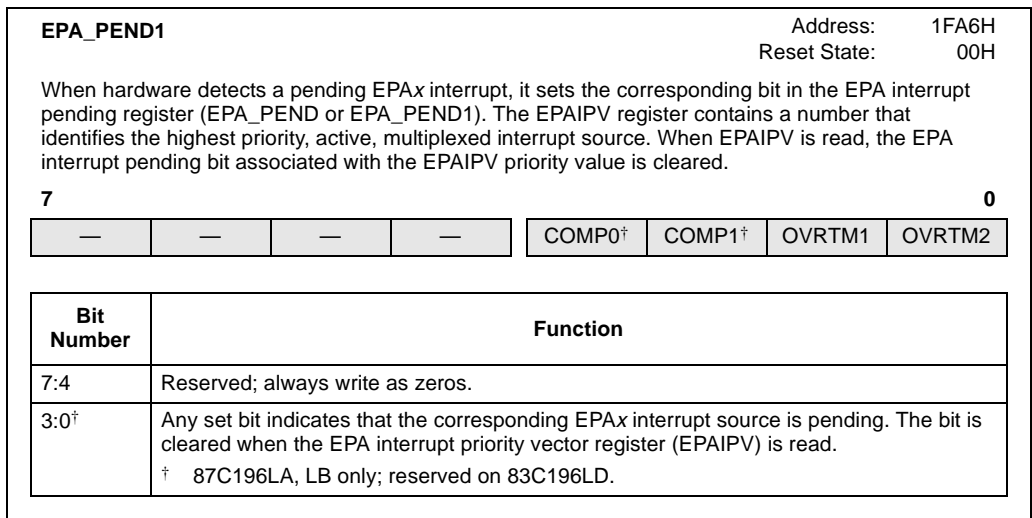

**Figure 7-6. EPA Interrupt Pending 1 (EPA\_PEND1) Register**

### 7.1.3 EPA Interrupt Priority Vector Register

Figure 7-7 illustrates the EPA interrupt priority vector (EPAIPV) register for the 8XC196Lx microcontroller family.

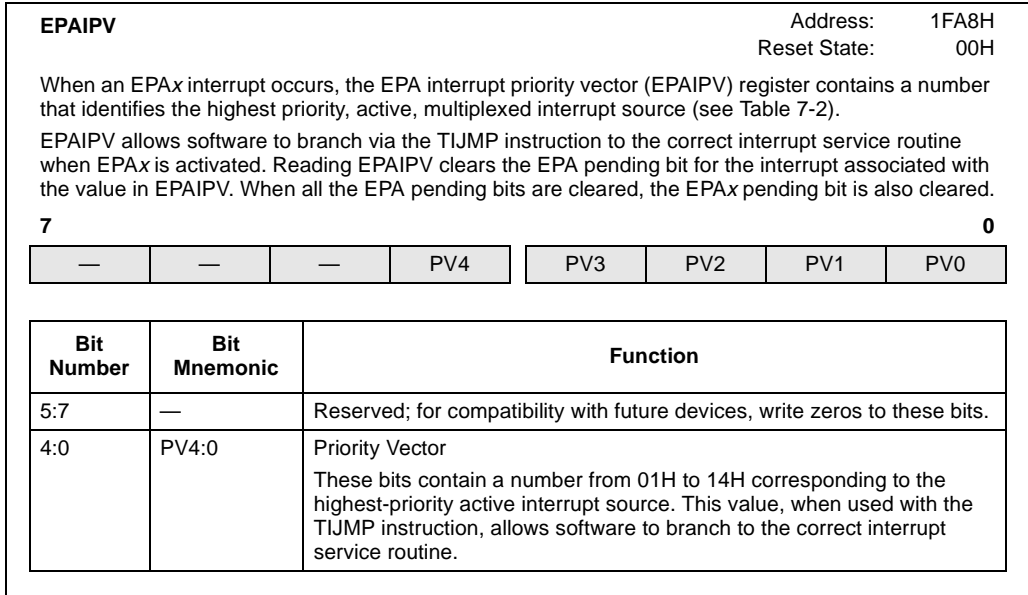

**Figure 7-7. EPA Interrupt Priority Vector Register (EPAIPV)**

**Table 7-2. EPA Interrupt Priority Vectors**

| Value | Interrupt | Value | Interrupt | Value | Interrupt |
|-------|-----------|-------|-----------|-------|-----------|
| 14H   | —         | 0DH   | OVR1      | 06H   | OVR8      |
| 13H   | —         | 0CH   | OVR2      | 05H   | OVR9      |
| 12H   | EPA6      | 0BH   | OVR3      | 04H   | COMP0†    |
| 11H   | EPA7      | 0AH   | —         | 03H   | COMP1†    |
| 10H   | EPA8      | 09H   | —         | 02H   | OVRTM1    |
| 0FH   | EPA9      | 08H   | —         | 01H   | OVRTM2    |
| 0EH   | OVR0      | 07H   | —         | 00H   | None      |

† 87C196LA, LB only; reserved on 83C196LD.



**J1850  
Communications  
Controller**



The J1850 communications controller manages communications between multiple network nodes. This integrated peripheral supports the 10.4 Kb/s VPW (variable pulse width) medium-speed class B in-vehicle network protocol. It also supports both the standard and in-frame response (IFR) message framing as specified by the *Society of Automotive Engineering (SAE) J1850* (revised May 1994) technical standards. Its lower cost per node makes it suitable for diagnostics and non-real-time data sharing in applications with high numbers of nodes. This chapter details the integrated J1850 controller and explains how to configure it.

### 8.1 J1850 FUNCTIONAL OVERVIEW

The integrated J1850 communications controller transfers messages between network nodes according to the J1850 protocol. The complete J1850 communications protocol solution includes an on-chip, J1850 digital-logic controller working with an external analog bus transceiver circuit. Figure 8-1 illustrates the J1850 protocol with the J1850 controller integrated on the 87C196LB 16-bit microcontroller and a standalone J1850 bus transceiver device. The example uses the *Harris HIP7020* as the remote transceiver device.

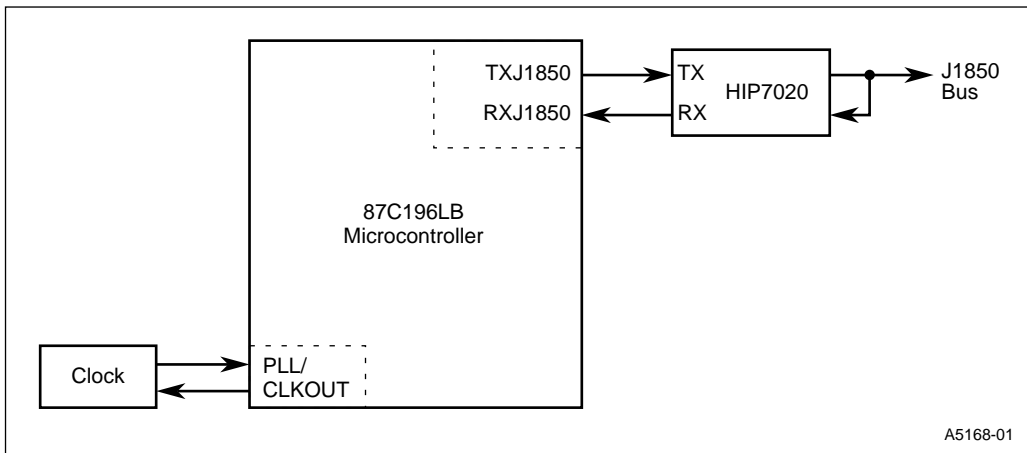

**Figure 8-1. Integrated J1850 Communications Protocol Solution**

The benefit of an integrated, J1850 protocol solution is threefold:

- Minimizes CPU overhead for reception and transmission of J1850 messages.
- Frees up serial and parallel communications ports for other purposes.
- Offers significant printed-circuit board area savings when compared with conventional standalone protocol devices.

The J1850 controller can handle network protocol functions including message frame sequencing, bit arbitration, in-frame response (IFR) messaging, error detection, and delay compensation.

The J1850 communications controller (Figure 8-2) consists of a control state machine (CSM), symbol synchronization and timing (SST) circuitry, six control and status registers, transmit and receive buffers, and an interrupt handler.

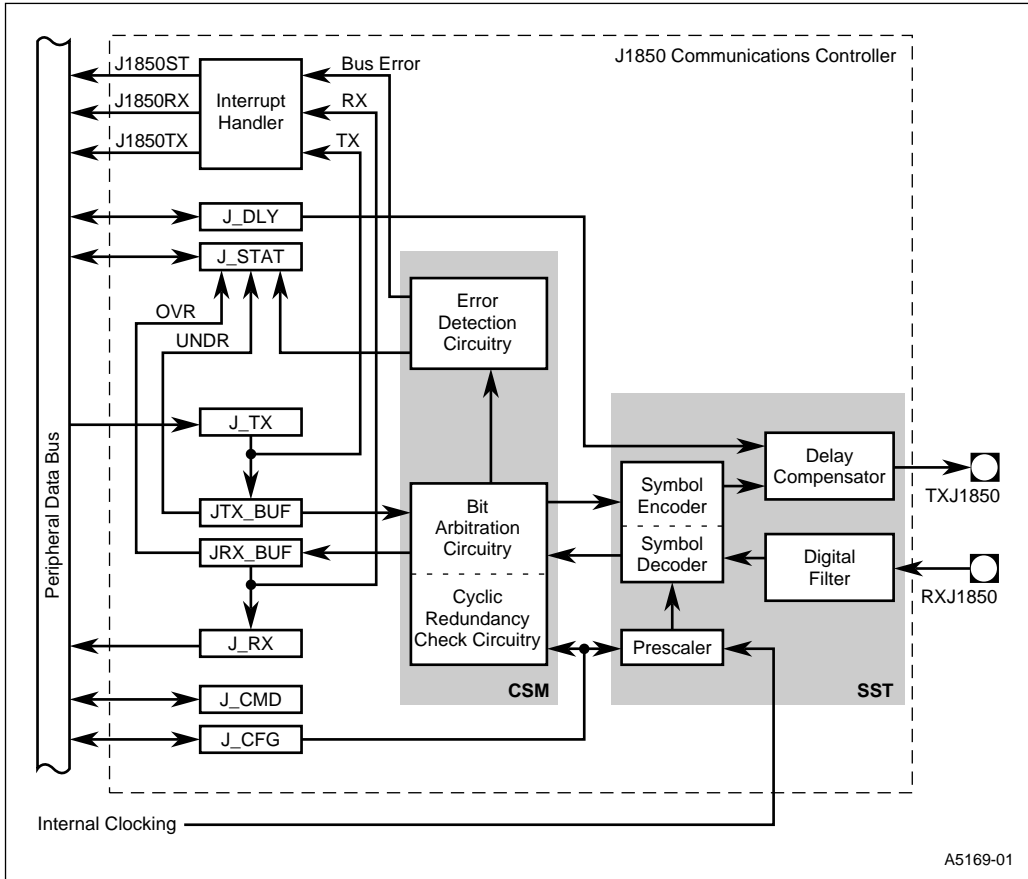

Figure 8-2. J1850 Communications Controller Block Diagram

## 8.2 J1850 CONTROLLER SIGNALS AND REGISTERS

Table 8-1 describes the J1850 controller’s pins, and Table 8-2 describes the control and status registers.

**Table 8-1. J1850 Controller Signals**

| Signal  | Type | Description  |
|---------|------|--|
| RXJ1850 | I    | Receive<br>Carries digital symbols from a remote transceiver to the J1850 controller.  |
| TXJ1850 | O    | Transmit<br>Carries digital symbols from the J1850 controller to a remote transceiver. |

**Table 8-2. Control and Status Registers**

| Mnemonic | Address | Description   |
|----------|---------|---|
| J_CFG    | 1F54H   | J1850 Configuration<br>Program this byte register to specify the oscillator prescaler divisor, mode of operation, and normalization bit format. You must write to this register during the initialization sequence.   |
| J_CMD    | 1F51H   | J1850 Command<br>Program this byte register to specify the number of bytes to be transmitted in the next message frame. This register also monitors the status of the message transmission in progress, and it can abort, ignore, or retry a message if necessary. Read this register to determine the status of transmissions in progress. |
| J_DLY    | 1F58H   | J1850 Delay Compensation<br>Program this byte register to define the length of the delay time through the external transceiver to compensate for the inherent propagation delays and to accurately resolve bus contention during arbitration. You must write to this register during the initialization sequence.                           |
| J_RX     | 1F52H   | J1850 Receiver<br>Read this byte register to receive data in byte increments from the J1850 bus to the microcontroller CPU. This register is buffered to allow for reception of a second data byte while the first data byte is being read.   |
| J_STAT   | 1F53H   | J1850 Status<br>Read this byte register to determine the current status of the receive and transmit buffers and the J1850 interrupt sources. You can also determine bus status and in-frame response messaging status. All bits of this register are cleared when read, with the exception of the BUS_STAT bit.                             |
| J_TX     | 1F50H   | J1850 Transmitter<br>Program this byte register to transmit data in byte increments to the J1850 bus from the microcontroller CPU. This register is buffered to allow for writing of a second data byte while the first data byte is being shifted out.   |

Table 8-2. Control and Status Registers (Continued)

| Mnemonic  | Address | Description  |
|-----------|---------|--|
| INT_MASK  | 0008H   | Interrupt Mask<br>Bits 6 and 7 in this register enable and disable the J1850 receive and transmit interrupt requests, respectively.  |
| INT_MASK1 | 0013H   | Interrupt Mask 1<br>Bit 0 in this register enables and disables the J1850 bus error interrupt request.   |
| INT_PEND  | 0009H   | Interrupt Pending<br>Bits 6 and 7 in this register, when set, indicate pending J1850 receive and transmit interrupt requests, respectively.  |
| INT_PEND1 | 0012H   | Interrupt Pending 1<br>Bit 0 in this register, when set, indicates a pending J1850 bus error interrupt request.  |
| PTSEL     | 0004H   | PTS Select<br>Bits 6, 7, and 8 of this word register select either a PTS service request or a standard interrupt service request for J1850TX, J1850RX, and J1850ST interrupts, respectively. |
| PTSSRV    | 0006H   | PTS Service<br>Bits 6, 7, and 8 of this word register are set by hardware to request an end-of-PTS interrupt for the J1850.  |

### 8.3 J1850 CONTROLLER OPERATION

This section describes the control state machine (which contains the cyclic redundancy check generator) and the symbol synchronization and timing circuitry for J1850 transmissions and receptions.

#### 8.3.1 Control State Machine

The control state machine (CSM) represents the engine of the digital circuitry portion of the J1850 communications controller. The CSM handles all message framing for standard and in-frame response (IFR) messaging, data validation, bus contention, bit arbitration, and error detection.

##### 8.3.1.1 Cyclic Redundancy Check Generator

The *cyclic redundancy check (CRC)* generator circuitry calculates and checks the CRC byte generated for both transmitted and received standard messages as specified by *SAE J1850* protocol specification for class B in-vehicle networks. The CRC calculation is a code byte of information that verifies the proper reception or transmission of your message. The calculated CRC code byte is always appended as the last byte of your transmitted message. On reception, the calculated CRC checksum byte always results in a value of C4H for valid messages. An invalid CRC checksum during reception signals the presence of an error in your incoming message, which immediately sets the J1850 bus error (J1850BE) bit in the J\_STAT register (Figure 8-19 on page 8-21).

### 8.3.1.2 Bus Contention

Bus contention arises when multiple nodes attempt to access and transmit message frames across the J1850 bus simultaneously. This creates a conflict on the bus. The recognition of conflicting symbols or bits on the bus is referred to as *contention detection*. For example, if a node observes a difference between a symbol it transmits to the J1850 bus and the symbol that it detects on the bus, that node has detected contention to the transmission of its message frame. Only one message frame from one node vying for the bus wins arbitration on each symbol or bit of its frame. This winning message frame does not experience or detect contention. The message frames that were not awarded arbitration will experience contention.

### 8.3.1.3 Bit Arbitration

A *bit arbitration* scheme is used to resolve such conflicts as bus contention. The J1850 protocol uses the carrier sense multiple access (CSMA) bit arbitration scheme. Bit arbitration is the process of settling conflicts that occur when multiple nodes attempt to transmit one bit or symbol at a time across a single bus. A symbol is simply a timing-level formatted bit. By definition, a node that detects contention has lost arbitration and will discontinue transmitting any further symbols remaining in its message frame. Remaining nodes vying for the bus will continue to send their symbols until the next instance of contention is detected or arbitration is awarded. This process continues until a complete message frame from one node has been transmitted. For details on this arbitration scheme, refer to the “Bit Arbitration Example” on page 8-7.

### 8.3.1.4 Error Detection

The J1850 controller’s error detection logic monitors the bus for four error conditions, and sets the J1850BE interrupt pending bit in the J\_STAT register if an error occurs. The following list describes each error type:

- CRC error — the calculated CRC checksum received on incoming messages has a value other than C4H (the expected value for all received message frames).
- bus symbol timing error — the symbol stream on the J1850 bus contains an invalid symbol. An invalid symbol is any signal that is between 8  $\mu$ s and 34  $\mu$ s in duration.
- incomplete byte error — an EOD/EOF symbol occurred, but was not on a byte boundary; the number of bits received was not a multiple of eight.
- no echo — the message is transmitted; however, the transmission’s echo back through the feedback loop to the receiver has not been detected within the allowable 60  $\mu$ s window.

## 8.3.2 Symbol Synchronization and Timing Circuitry

The symbol synchronization and timing (SST) circuitry consists of a clock prescaler, digital filter, delay compensation circuitry, and synchronization and symbol encoding/decoding circuitry. The SST supports Huntzicker encoding of symbols, which entails 10.4 Kb/s variable pulse-width (VPW) operation for valid edge detection on message receptions.

### 8.3.2.1 Clock Prescaler

Because the 87C196LB microcontroller can operate at a variety of input frequencies ( $F_{XTAL1}$ ), the clock prescaler circuitry is used to provide a single, internal clock frequency ( $f/2$ ) to ensure that the J1850 peripheral is clocked at the proper operating frequency. This is accomplished through the programmable clock prescaler bits, PRE1:0 in the J\_CFG register (Figure 8-17 on page 8-18). The prescale bits support input frequencies of 8, 12, 16, and 20 MHz on the XTAL1 pin. With the phase-locked loop (PLL) circuitry enabled, the prescale bits can support input frequencies of 4, 6, 8, and 10 MHz on the XTAL1 pin.

Table 8-3 details the relationships between the input frequency, the configuration of PLL, the internal clock frequency, and the prescaler bits.

**Table 8-3. Relationships Between Input Frequency, PLL, and Prescaler Bits**

| $F_{XTAL1}$     |                | Internal Clock Frequency<br>( $f/2$ ) | PRE1 | PRE0 |
|-----------------|----------------|---------------------------------------|------|------|
| PLL<br>Disabled | PLL<br>Enabled |                                       |      |      |
| 8 MHz           | 4 MHz          | 4 MHz                                 | 0    | 0    |
| 12 MHz          | 6 MHz          | 6 MHz                                 | 0    | 1    |
| 16 MHz          | 8 MHz          | 8 MHz                                 | 1    | 0    |
| 20 MHz          | 10 MHz         | 10 MHz                                | 1    | 1    |

### 8.3.2.2 Digital Filter

To automatically reject noise spikes of 8  $\mu$ s or less in duration, the J1850 controller uses a digital filter between the RXJ1850 input pin and the symbol synchronization logic.

A *noise spike* is defined as an active or passive state pulse that is shorter in duration than a valid receive symbol at that state. A valid receive symbol is at least 34  $\mu$ s in duration. Any symbol captured on the bus between 8  $\mu$ s and 34  $\mu$ s in duration is considered invalid and is flagged by the J\_STAT register as a bus-symbol timing error.

### 8.3.2.3 Delay Compensation

Because the digital portion of the J1850 protocol is integrated onto the microcontroller and physically separated from the transceiver and J1850 bus, control over critical timing parameters of various manufacturers' remote transceivers is required. The delay compensation circuitry addresses this requirement by providing the flexibility to compensate for propagation delay and pulse-width variations among various transceivers. The compensation circuitry synchronizes itself to the leading edge of each input symbol, which allows for accurate detection of bus contention during bit arbitration. The delay compensation is programmable through the J\_DLY register (Figure 8-18 on page 8-20).

### 8.3.2.4 Symbol Encoding and Decoding

The J1850 protocol supports the Huntzicker encoding method, which is based on *variable pulse-width (VPW)* bus modulation. VPW modulation is a forced high/low symbol transition formatting scheme that tracks the duration between two consecutive transitions and the level of the bus, active or passive (Figure 8-3).



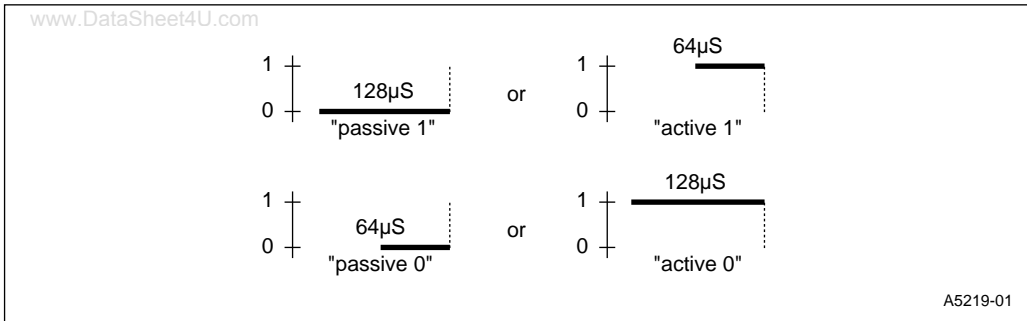

**Figure 8-3. Huntzicker Symbol Definition for J1850**

A symbol is defined as a timing-level formatted bit. The VPW symbol timing requirements stipulate that there is one symbol per transition and one transition per symbol. This ensures that a message frame will always result in a uniform square waveform of varying level durations. Figure 8-4 depicts a typical Huntzicker formatted data byte of hex value CCH.

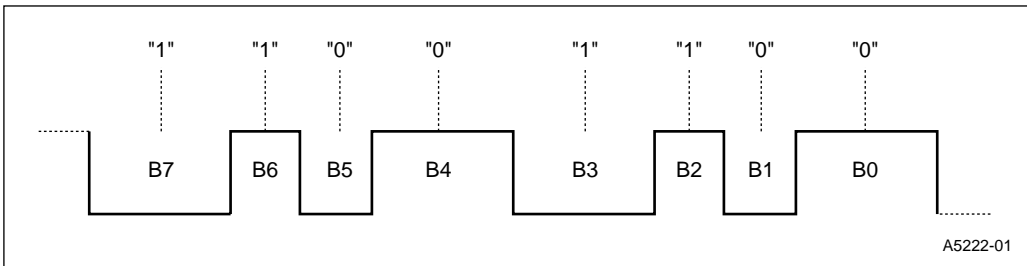

**Figure 8-4. Typical VPW Waveform**

Bits 7 and 3 carry logic level 1 data; however, they are represented by a passive-level symbol in keeping with the VPW requirements. Bits 4 and 0 carry logic level 0 data and are represented by an active-level symbol.

### 8.3.3 Bit Arbitration Example

The drive capacity of each symbol establishes the priority for arbitration. By definition, an active bus level is a driven state, and a passive bus level is a non-driven, or idle, state. A driven bus state is always given priority over an idle bus in arbitration. An “active 0” state has priority over an “active 1” state in arbitration, because the “active 0” state is driven over a longer duration, 128 µs versus the “active 1” state’s drive time of 64 µs. Similarly, a “passive 0” state has priority over a “passive 1” state, because the “passive 0” state comes out of its idle state in a shorter period of time, 64 µs versus the “passive 1” state’s idle time of 128 µs.

For example, Figure 8-5 illustrates four nodes vying for the bus. Node B is the first node to discontinue transmitting when it attempts to transmit a “passive 1” symbol onto the bus. At the point

of arbitration, nodes A, C, and D are all transmitting an “active 0” symbol, thus the idle state of the “passive 1” symbol is overruled in favor of the driven state of the “active 0” symbol.

Node C is the next node to discontinue transmitting when it attempts to take control of the bus by transmitting an “active 1” symbol. However, nodes A and D maintain control by continuing to drive the bus with an “active 0” symbol.

Finally, node D discontinues transmitting when its attempt to hold the bus in an idle state is overruled by the driven state of the “active 1” symbol on node A. Thus, node A is awarded arbitration.

The busline signal, detected on the bus by the receiver, reflects node A’s message, as this is the only node that did not experience contention.

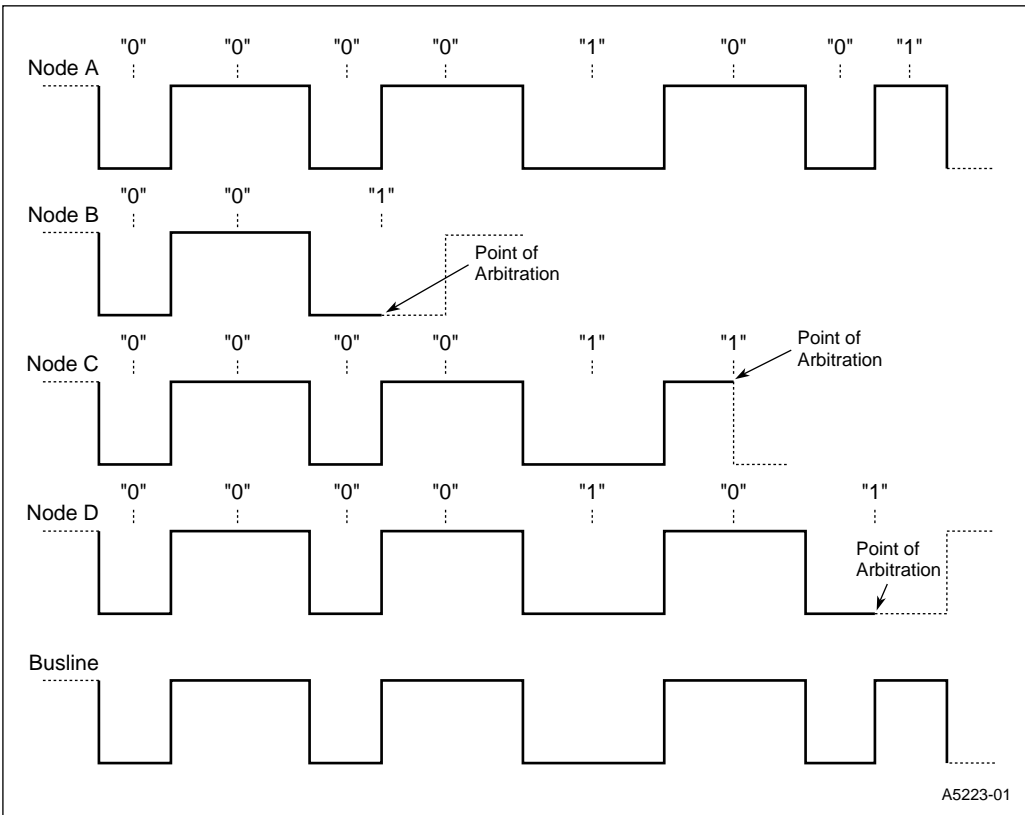
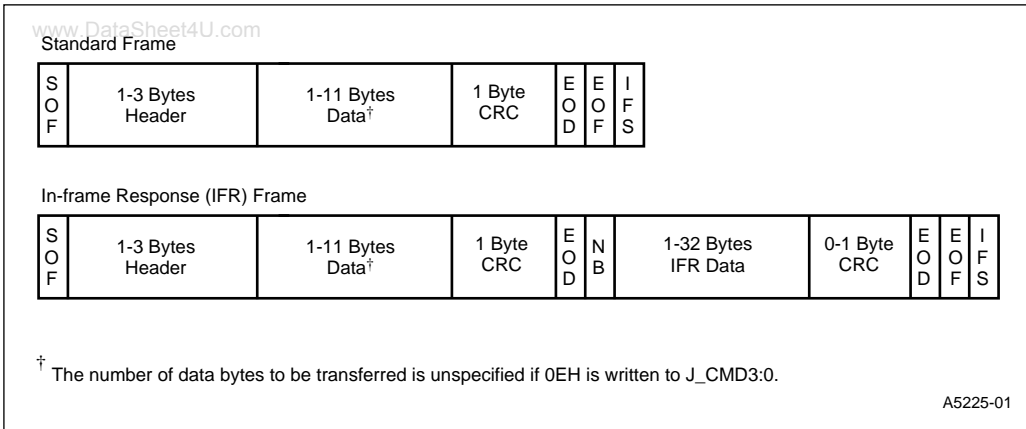

Figure 8-5. Bit Arbitration Example

### 8.4 MESSAGE FRAMES

A message transmission or reception is transferred within a message frame that adds control and error-detection bits to the content of the message. The frame for an IFR message differs slightly from that for a standard message, but they contain similar information (Figure 8-6).



**Figure 8-6. J1850 Message Frames**

A standard message frame is initiated by the responder and contains no more than 11 data bytes to be transmitted. An IFR message is a request initiating the recipient(s) to respond by transmitting data within the same frame. The following subsections describe each of the messaging forms.

### 8.4.1 Standard Messaging

A standard message frame can best be described as a “send mode only” format that is initiated by the responder either to request information or to reply to a received message from a remote node. In addition to the actual data that is being transmitted, the standard message is composed of a header (1–3 bytes), a CRC byte, and a series of start and end symbols.

#### 8.4.1.1 Header

The header provides general information on the physical network and the necessary interface requirements. For a complete description of the header, refer to the *Society of Automotive Engineering (SAE) J1850* specifications (revised May 1994).

#### 8.4.1.2 CRC Byte

The CRC byte, calculated through the cyclic redundancy check generator, is a checksum value that verifies the accuracy of the data message transmitted onto the bus. The CRC byte is appended to all data messages and optionally appended to IFR response messages. Upon reception, the CRC byte is compared with the value C4H. If the values match, the transmitted message is valid; otherwise, it is invalid, and an error flag in the J\_STAT register is set.

#### 8.4.1.3 Normalization Bit

The normalization bit (NB), found only in IFR messaging, defines the start of the IFR message response data. The NB is triggered by bit J\_CMD.6 and is transmitted after an end-of-data (EOD) symbol is detected on the bus. The timing format of the NB is assigned by the J\_CFG register

(J\_CFG.7) and considers whether the IFR message response has a CRC byte appended. Figure 8-7 depicts the SAE preferred, active-level state bit format timing for the NB.

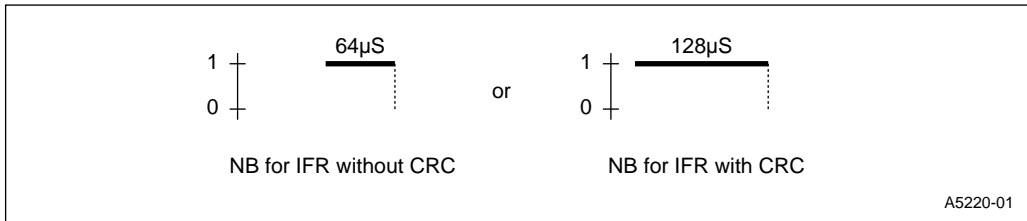

**Figure 8-7. Hantzicker Symbol Definition for the Normalization Bit**

#### 8.4.1.4 Start and End Message Frame Symbols

Five symbols are used to mark the start and end of a message frame and to allow the J1850 bus to properly recognize the interruption of a message transmission or reception. Figure 8-8 illustrates the formats and their respective timing.

The following is a description of each symbol:

- start of frame (SOF) — this symbol signals the start of a message frame. This is an active-level state symbol only and appears once per frame.
- end of data (EOD) — this symbol signals the end of the data transmission. This is a passive-level state symbol only. It appears twice in IFR messaging: at the end of the initial request data field and at the end of the IFR data field.
- end of frame (EOF) — this symbol signals the end of a message frame and returns the bus to an idle state. This is a passive-level state symbol only. It appears once per frame.
- in-frame separation (IFS) — the timing of this symbol allows for proper synchronization of multiple nodes during back-to-back transmissions. Nodes contending for the bus must comply with one of two conditions before transmitting:
  - wait for the IFS minimum timing to expire
  - wait for a rising edge on the bus after the EOF minimum timing has expired
- break (BRK) — this symbol signals an interruption during a bus transmission. At the point of termination, all nodes are reset. This is an active-level state symbol.

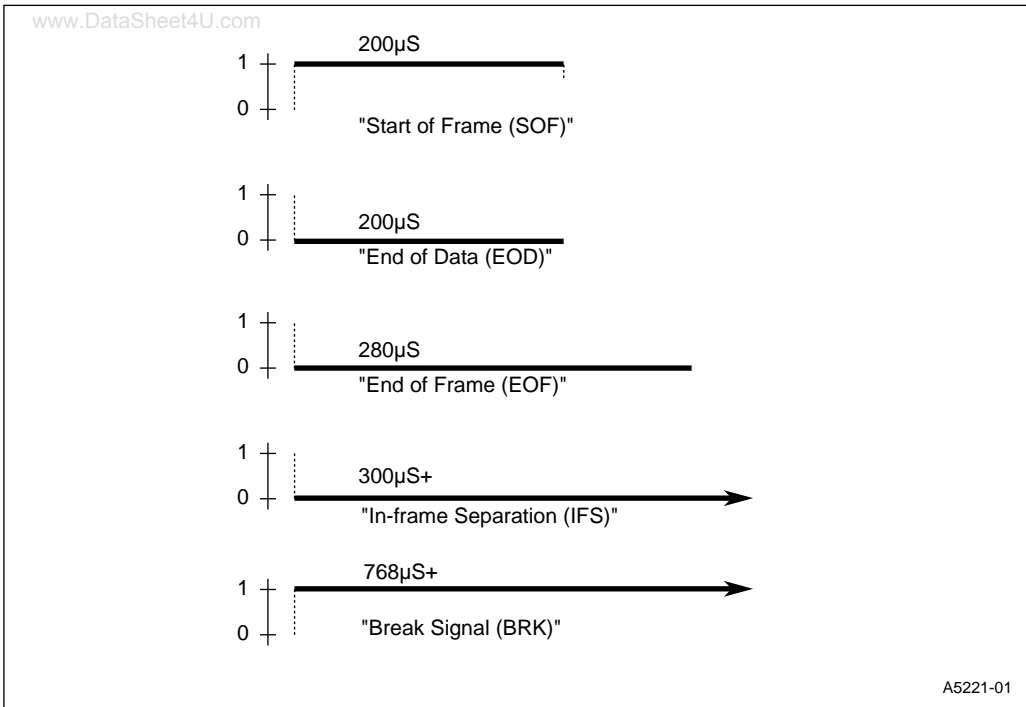

**Figure 8-8. Definition for Start and End of Frame Symbols**

Table 8-4 details the symbol timing characteristics supported by the 87C196LB.

**Table 8-4. Huntzicker Symbol Timing Characteristics**

| Name                | Symbol | Bus Level | T <sub>TX</sub> min | T <sub>TX</sub> nom | T <sub>TX</sub> max | T <sub>RX</sub> min | T <sub>RX</sub> max | Units |
|---------------------|--------|-----------|---------------------|---------------------|---------------------|---------------------|---------------------|-------|
| Logic Level 0       | 0      | Passive   | 60                  | 64                  | 68                  | 34                  | <96                 | µs    |
|                     |        | Active    | 122                 | 128                 | 134                 | 96                  | <163                | µs    |
| Logic Level 1       | 1      | Passive   | 122                 | 128                 | 134                 | 96                  | <163                | µs    |
|                     |        | Active    | 60                  | 64                  | 68                  | 34                  | <96                 | µs    |
| Start of Frame      | SOF    | Active    | 193                 | 200                 | 207                 | 163                 | <239                | µs    |
| End of Data         | EOD    | Passive   | 193                 | 200                 | 207                 | 163                 | <239                | µs    |
| End of Frame        | EOF    | Passive   | 271                 | 280                 | 289                 | 239                 | <300                | µs    |
| In-frame Separation | IFS    | Passive   | >300                | —                   | —                   | >300                | —                   | µs    |
| Break               | BRK    | Active    | 768                 | —                   | —                   | >239                | —                   | µs    |

**NOTE:** Timings are based on the standard bus rate of 10.4 Kb/s. When operating in 4x mode, the bus rate becomes 41.6 Kb/s and all symbol timings are one fourth that shown.

### 8.4.2 In-frame Response Messaging

There are three types of in-frame response (IFR) message framings: type 1 (a single byte from a single responder), type 2 (a single byte from multiple responders), and type 3 (multiple bytes from a single responder). Like the standard message frame, the IFR frame is composed of header, data, and CRC bytes, and a series of start and end symbols. Unlike the standard message frame, the actual length of the IFR message frame will differ based on the desired response.

Consider the following example: a system’s controller (the requestor) requests an information update from each of four nodes (the responders) in the system. With type 1 messaging, the controller can receive a limited information update if it sends out four separate transmissions. With type 2 messaging, the controller can receive a limited information update by sending one message. With type 3 messaging, the controller can receive unlimited information; however, it will require four separate transmissions. The following subsections detail this example for the three IFR messaging types.

#### 8.4.2.1 IFR Messaging Type 1: Single Byte, Single Responder

No IFR messaging type carries a distinct advantage or disadvantage over the other messaging types. IFR messaging type 1 (Figure 8-9) is ideal for use when requesting small amounts of information from a single source in your system. In the above example, suppose you want to know how many pounds of pressure each of the four remote node sites experienced after the controller sent out a request to each node sensor to exert a given amount of pressure. If you use type 1 messaging, the controller will send four separate serial messages to the remote node sites in the system and wait for their responses. Keeping the data timing a constant, the CPU overhead of transmitting these messages alone amounts to a minimum of 4.96 ms (refer to Table 8-4 on page 8-11 for all symbol timings).

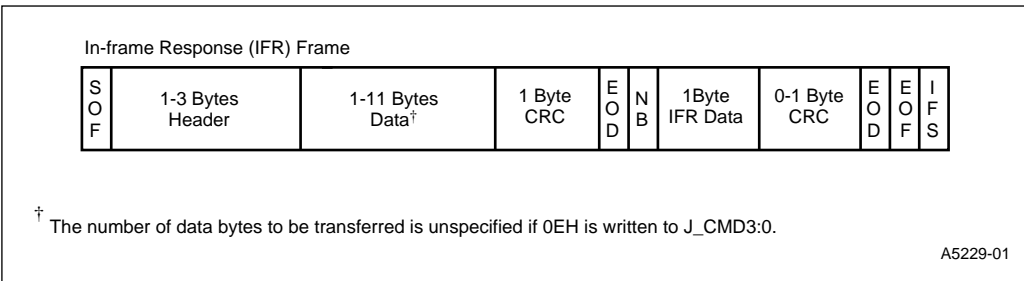

**Figure 8-9. IFR Type 1 Message Frame**

#### 8.4.2.2 IFR Messaging Type 2: Single Byte, Multiple Responders

When response time is the highest consideration, IFR messaging type 2 is desirable. IFR type 2 messaging can monitor up to 32 remote nodes on a given request (see Figure 8-10). While it allows only one byte of information per response, in many cases a single byte of information is more than adequate. In our example, suppose that each node sensor detected a pressure of 75 P.S.I. (pounds per square inch). The response (the value 75) would take a single byte, 46H, to communicate the reply. The maximum overhead required is 1.24 ms, or one fourth the time it would take type 1 messaging to achieve the same results.

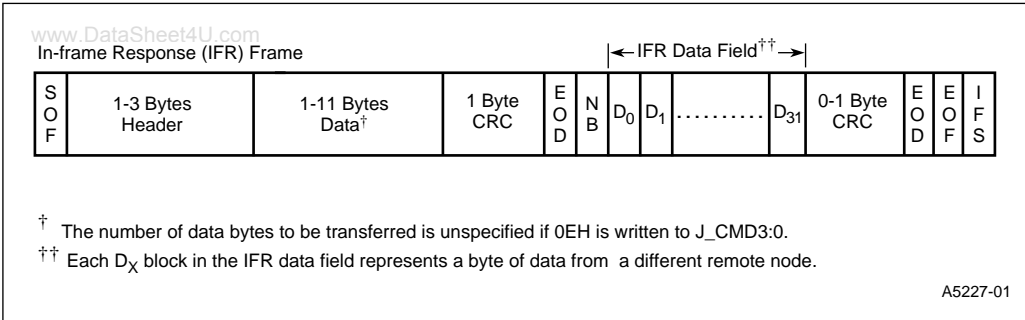

**Figure 8-10. IFR Type 2 Message Frame**

**8.4.2.3 IFR Messaging Type 3: Multiple Bytes, Single Responder**

IFR messaging type 3 (Figure 8-11) is ideal for requesting large amounts of information from a single source in your system. You can compile up to 12 bytes of data from a remote node on a single request. In our example, for the same amount of CPU overhead as IFR type 1 messaging exhausted (4.96 ms), you can gather up to twelve times as much information.

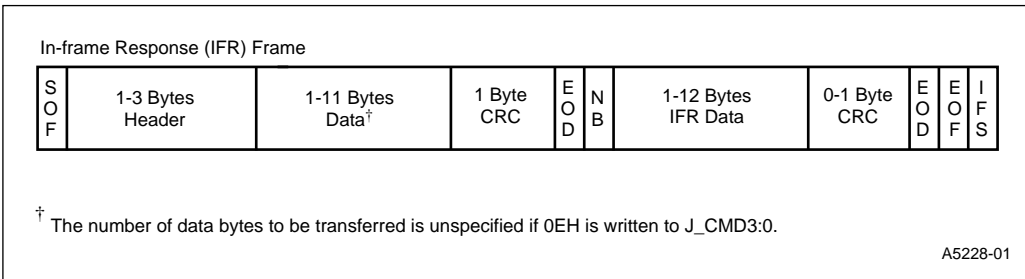

**Figure 8-11. IFR Type 3 Message Frame**

**8.5 TRANSMITTING AND RECEIVING MESSAGES**

The J1850 controller can transmit and receive messages in either standard or IFR form.

**8.5.1 Transmitting Messages**

To transmit a standard message, prepare the message in register RAM and then write it to the J1850 transmit (J\_TX) register (Figure 8-12) one byte at a time.

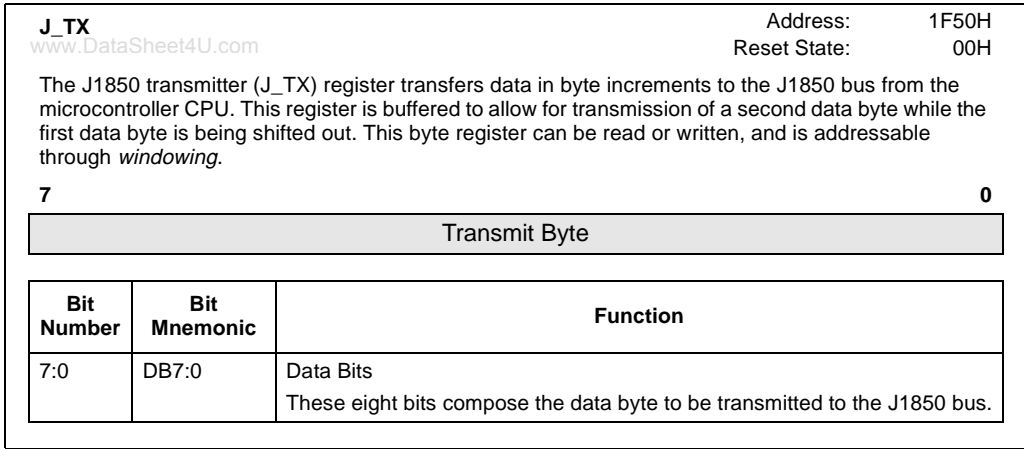

**Figure 8-12. J1850 Transmitter (J\_TX) Register**

Transmitting the message requires that you first program the J1850 command (J\_CMD) register to specify the number of bytes you want to transfer across the J1850 bus. The number of bytes specified must include the header byte(s). After the start of frame (SOF) symbol is put on the bus, the first header byte is transferred to J\_TX for transmission. This byte will automatically be transferred into the J1850 transmit buffer (JTX\_BUF) and the second byte of the message frame will be written to J\_TX. The transfer of the first byte to JTX\_BUF triggers the transmission process and generates the J1850 transmission (J1850TX) interrupt (if it is enabled), signaling that J\_TX is available for another byte (Figure 8-13).

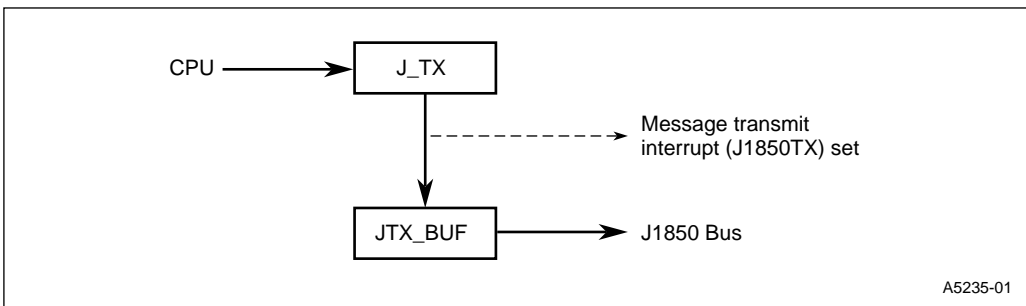

**Figure 8-13. J1850 Transmit Message Structure**

After the byte in JTX\_BUF is transmitted, the byte residing in J\_TX is automatically shifted into JTX\_BUF, freeing J\_TX for another byte. This process continues until the CSM has resolved the number of message bytes (MSG3:0) programmed into the J\_CMD register.

If the last message byte being transmitted is shifted out before the MSGx count expires, a J1850ST core interrupt is generated and the OVR\_UNDR (J\_STAT.3) bit records a transmitter underflow error in the J\_STAT register.



**NOTE**

An overrun condition can occur on transmission if the transmit buffer, JTX\_BUF, is overwritten.

**8.5.2 Receiving Messages**

For a message reception, after a SOF is detected on the bus, the controller starts to shift data symbols into the J1850 receive buffer (JRX\_BUF) until an entire data byte has been received. This byte is automatically transferred into the J1850 receive (J\_RX) register (Figure 8-14) and the subsequent byte is written into the empty JRX\_BUF.

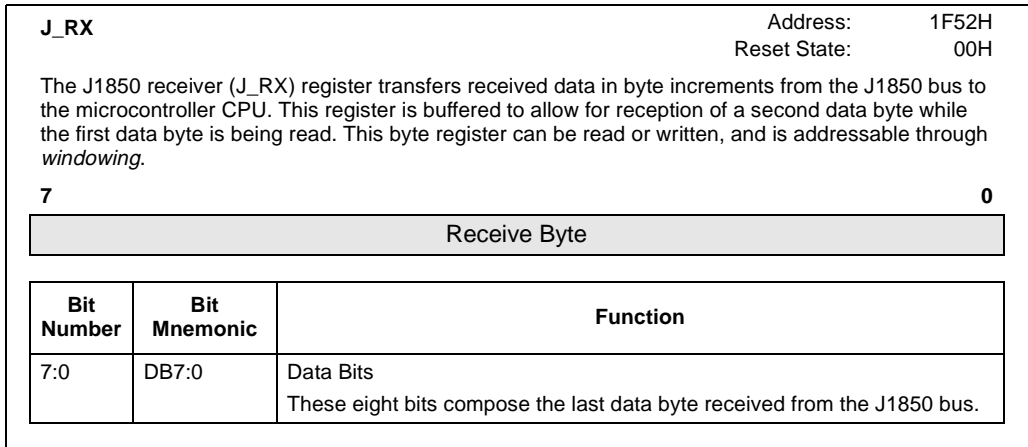

**Figure 8-14. J1850 Receiver (J\_RX) Register**

The transfer of the first byte to J\_RX triggers the reception process and generates the J1850 reception (J1850RX) interrupt (if it is enabled), signaling that JRX\_BUF is available for another byte (Figure 8-15).

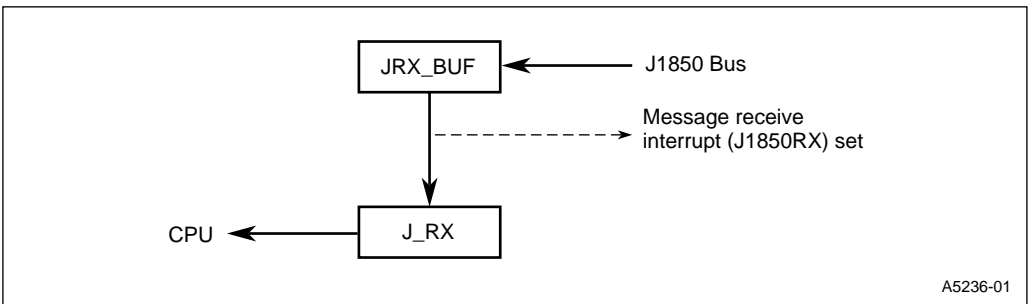

**Figure 8-15. J1850 Receive Message Structure**

After J\_RX is read, the byte residing in JRX\_BUF is automatically shifted into J\_RX, freeing JRX\_BUF for another reception. This process continues until an end of data (EOD) symbol is encountered.

If a third byte is received before J\_RX is read, a J1850ST core interrupt is generated and the OVR\_UNDR (J\_STAT.3) bit records a receiver overrun error in the J\_STAT register.

### 8.5.3 IFR Messages

In-frame response (IFR) messaging is identical in setup to standard messaging for both transmission and reception. It uses the same registers to configure, communicate, and control data. The difference is that the requestor initiating the IFR message sequence writes the message specifying a response from either one or more nodes in the system. Framing a message in this manner bypasses needless CPU overhead that can result from lengthy EOF symbols, and it gives you a faster response to the information you are accessing from remote sites in your system. (Refer to “In-frame Response Messaging” on page 8-12 for a detailed explanation).

## 8.6 PROGRAMMING THE J1850 CONTROLLER

This section explains how to configure the J1850 controller. Several registers combine to control the configuration: the command register, the configuration register, the delay compensation register, and the status register.

Programming the J1850 controller requires that you first program the configuration and delay registers during initialization. You need to program these two registers only once per initialization sequence.

After initialization, you must first program the command register, followed by either the receive or transmit register, and then the status register.

### 8.6.1 Programming the J1850 Command (J\_CMD) Register

The J1850 command register (Figure 8-16) determines the messaging type, specifies the number of bytes to be transmitted in the next message frame, and updates the status of the message transmission in progress.

| <b>J_CMD</b>  |                    | Address:  | 1F51H    |        |           |         |    |                  |                              |    |                    |                                      |    |          |   |    |          |   |      |                  |                                    |
|---|--------------------|---|----------|--------|-----------|---------|----|------------------|------------------------------|----|--------------------|--------------------------------------|----|----------|---|----|----------|---|------|------------------|------------------------------------|
| <a href="http://www.DataSheet4U.com">www.DataSheet4U.com</a>  |                    | Reset State:  | 00H      |        |           |         |    |                  |                              |    |                    |                                      |    |          |   |    |          |   |      |                  |                                    |
| <p>The J1850 command (J_CMD) register determines the messaging type, specifies the number of bytes to be transmitted in the next message frame, and updates the status of the message transmission in progress. This byte register can be directly addressed through <i>windowing</i>. You must write to this register prior to transmitting every message.</p> |                    |   |          |        |           |         |    |                  |                              |    |                    |                                      |    |          |   |    |          |   |      |                  |                                    |
| <b>7</b>  |                    |   | <b>0</b> |        |           |         |    |                  |                              |    |                    |                                      |    |          |   |    |          |   |      |                  |                                    |
| AUTO  | IFR                | IGNORE  | ABORT    |        |           |         |    |                  |                              |    |                    |                                      |    |          |   |    |          |   |      |                  |                                    |
|   |                    | MSG3  | MSG2     |        |           |         |    |                  |                              |    |                    |                                      |    |          |   |    |          |   |      |                  |                                    |
|   |                    | MSG1  | MSG0     |        |           |         |    |                  |                              |    |                    |                                      |    |          |   |    |          |   |      |                  |                                    |
| Bit Number  | Bit Mnemonic       | Function  |          |        |           |         |    |                  |                              |    |                    |                                      |    |          |   |    |          |   |      |                  |                                    |
| 7   | AUTO               | <p>Automatic Transmit Retry</p> <p>This bit, when arbitration is lost on the first byte of your message, prompts the transmitter to automatically retry until the byte is successfully transmitted. Automatic retry applies only to the first byte.</p> <p>0 = normal operation<br/>1 = enable automatic retry</p>  |          |        |           |         |    |                  |                              |    |                    |                                      |    |          |   |    |          |   |      |                  |                                    |
| 6   | IFR                | <p>In-frame Response Indicator</p> <p>This bit signals that a normalization bit (NB) is to be sent after an end-of-data symbol is detected on the bus and that the subsequent byte written to the J1850 transmitter (J_TX) register is an in-frame response (IFR).</p> <p>0 = standard messaging<br/>1 = next byte written to J_TX is an IFR</p>  |          |        |           |         |    |                  |                              |    |                    |                                      |    |          |   |    |          |   |      |                  |                                    |
| 5   | IGNORE             | <p>Ignore Incoming Message</p> <p>This bit instructs the bus to ignore the incoming message until an EOF symbol is detected. The bit is cleared after an EOF symbol is detected.</p> <p>0 = normal operation<br/>1 = ignore incoming message</p>  |          |        |           |         |    |                  |                              |    |                    |                                      |    |          |   |    |          |   |      |                  |                                    |
| 4   | ABORT              | <p>Abort Transmission</p> <p>This bit aborts any transmission in progress and flushes the transmit buffer (JTX_BUF). To prevent another node from mistakenly assuming that the last byte was a CRC byte, two extra '1's are appended.</p> <p>0 = normal operation<br/>1 = abort transmission in progress</p>  |          |        |           |         |    |                  |                              |    |                    |                                      |    |          |   |    |          |   |      |                  |                                    |
| 3:0   | MSG3:0             | <p>Message</p> <p>These four bits specify the number of bytes to be transmitted in the next message frame. This number includes the header, but not the CRC byte. In normal messaging, the maximum number of bytes you can transmit in a message frame is eleven.</p> <table border="1" style="width: 100%; border-collapse: collapse;"> <thead> <tr> <th style="text-align: left;">MSG3:0</th> <th style="text-align: left;">Operation</th> <th style="text-align: left;">Purpose</th> </tr> </thead> <tbody> <tr> <td>FH</td> <td>Termination byte</td> <td>Terminate block transmission</td> </tr> <tr> <td>EH</td> <td>Block transmission</td> <td>Transmit unspecified number of bytes</td> </tr> <tr> <td>DH</td> <td>Reserved</td> <td>—</td> </tr> <tr> <td>CH</td> <td>Reserved</td> <td>—</td> </tr> <tr> <td>B:0H</td> <td>Normal messaging</td> <td>Transmit specified number of bytes</td> </tr> </tbody> </table> |          | MSG3:0 | Operation | Purpose | FH | Termination byte | Terminate block transmission | EH | Block transmission | Transmit unspecified number of bytes | DH | Reserved | — | CH | Reserved | — | B:0H | Normal messaging | Transmit specified number of bytes |
| MSG3:0  | Operation          | Purpose   |          |        |           |         |    |                  |                              |    |                    |                                      |    |          |   |    |          |   |      |                  |                                    |
| FH  | Termination byte   | Terminate block transmission  |          |        |           |         |    |                  |                              |    |                    |                                      |    |          |   |    |          |   |      |                  |                                    |
| EH  | Block transmission | Transmit unspecified number of bytes  |          |        |           |         |    |                  |                              |    |                    |                                      |    |          |   |    |          |   |      |                  |                                    |
| DH  | Reserved           | —   |          |        |           |         |    |                  |                              |    |                    |                                      |    |          |   |    |          |   |      |                  |                                    |
| CH  | Reserved           | —   |          |        |           |         |    |                  |                              |    |                    |                                      |    |          |   |    |          |   |      |                  |                                    |
| B:0H  | Normal messaging   | Transmit specified number of bytes  |          |        |           |         |    |                  |                              |    |                    |                                      |    |          |   |    |          |   |      |                  |                                    |

Figure 8-16. J1850 Command (J\_CMD) Register

### 8.6.2 Programming the J1850 Configuration (J\_CFG) Register

The J1850 configuration register (Figure 8-17) selects the proper oscillator prescaler, initiates a transmission break for debugging, invokes clock quadrupling operation, and selects the normalization bit format.

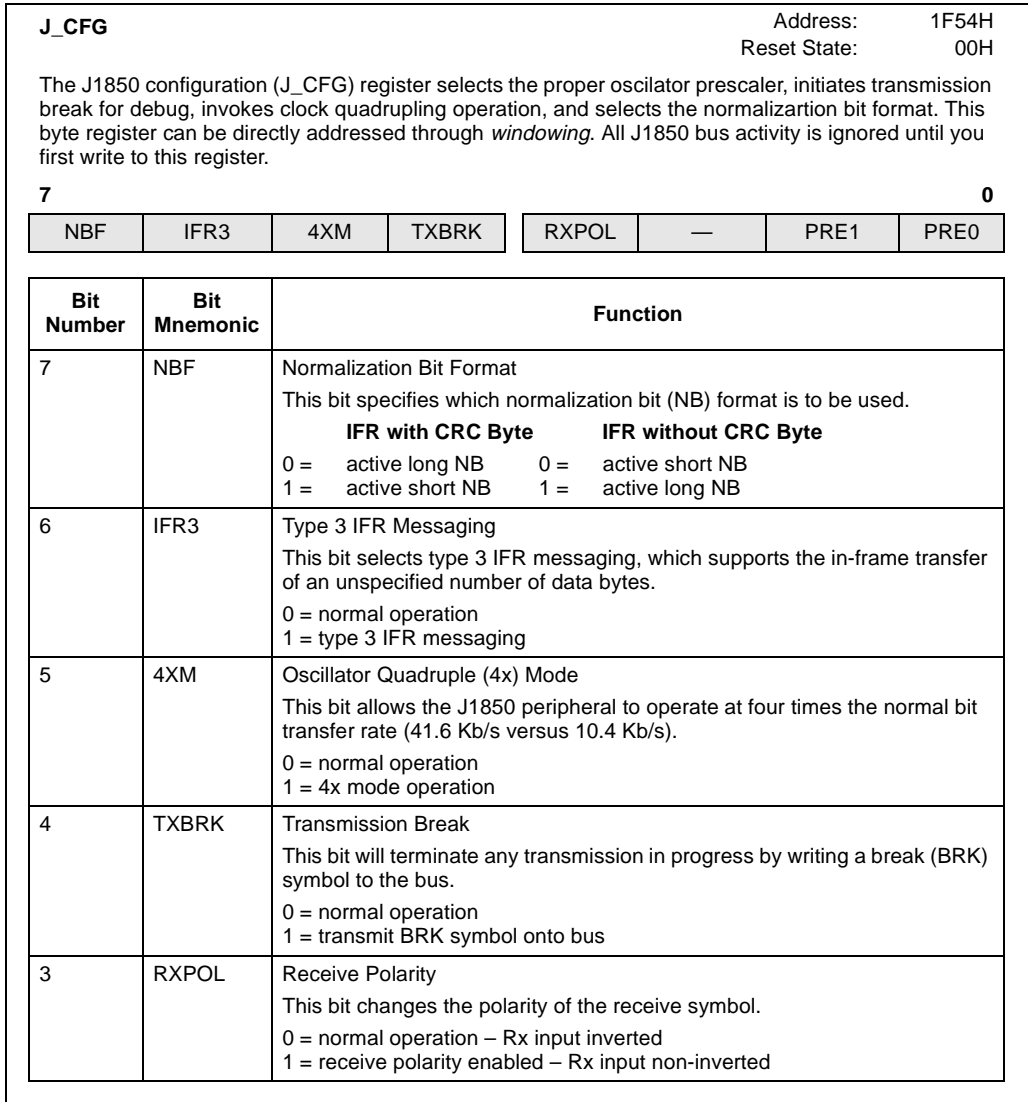

**Figure 8-17. J1850 Configuration (J\_CFG) Register**

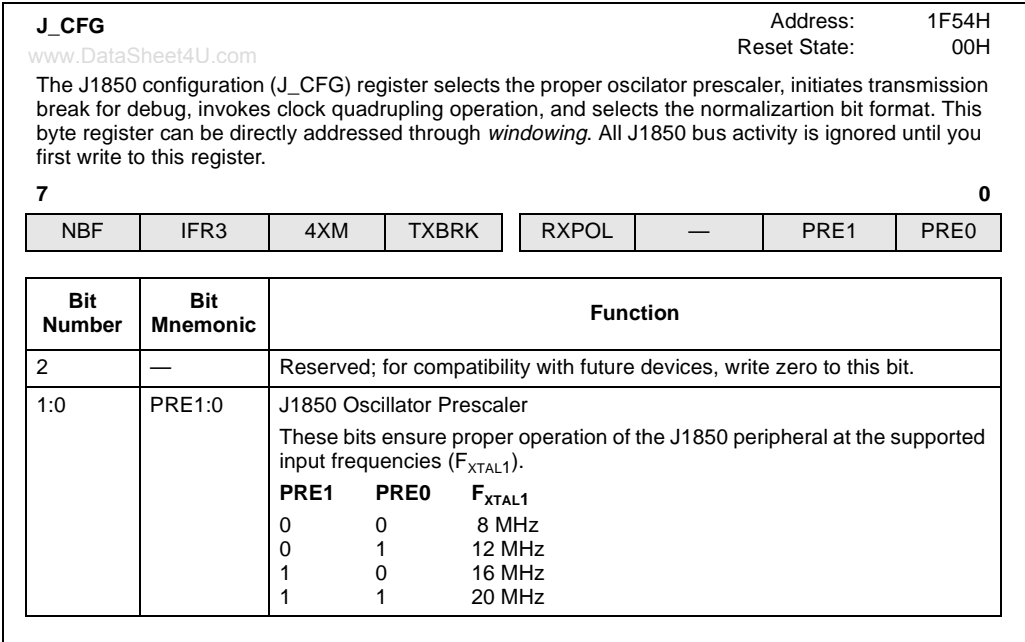
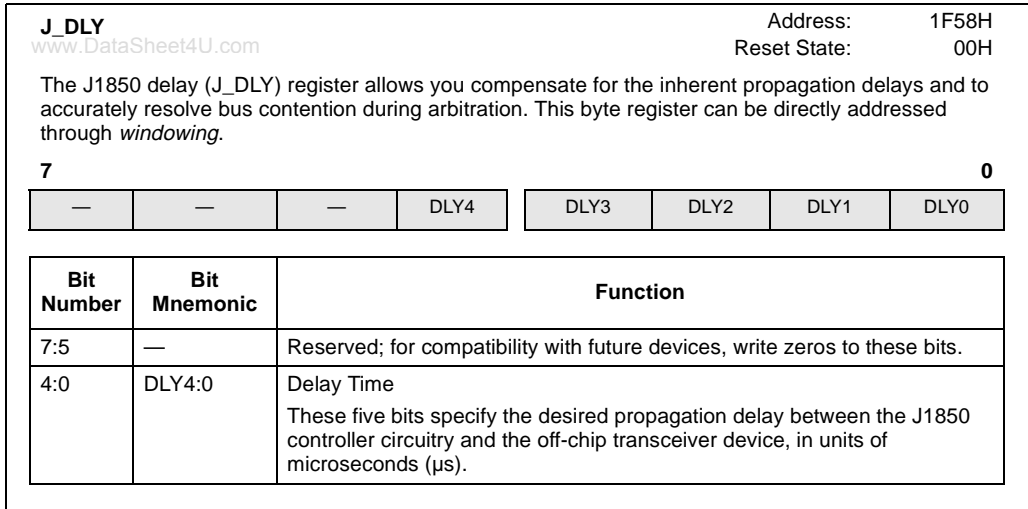

Figure 8-17. J1850 Configuration (J\_CFG) Register (Continued)

### 8.6.3 Programming the J1850 Delay Compensation (J\_DLY) Register

The J1850 delay compensation register (Figure 8-18) allows you to program the necessary delay time through the external transceiver to compensate for the inherent propagation delays and to accurately resolve bus contention during arbitration.



**Figure 8-18. J1850 Delay (J\_DLY) Register**

### 8.6.4 Programming the J1850 Status (J\_STAT) Register

The J1850 status register (Figure 8-19) provides the current status of the message and the four interrupt sources associated with the J1850 protocol.

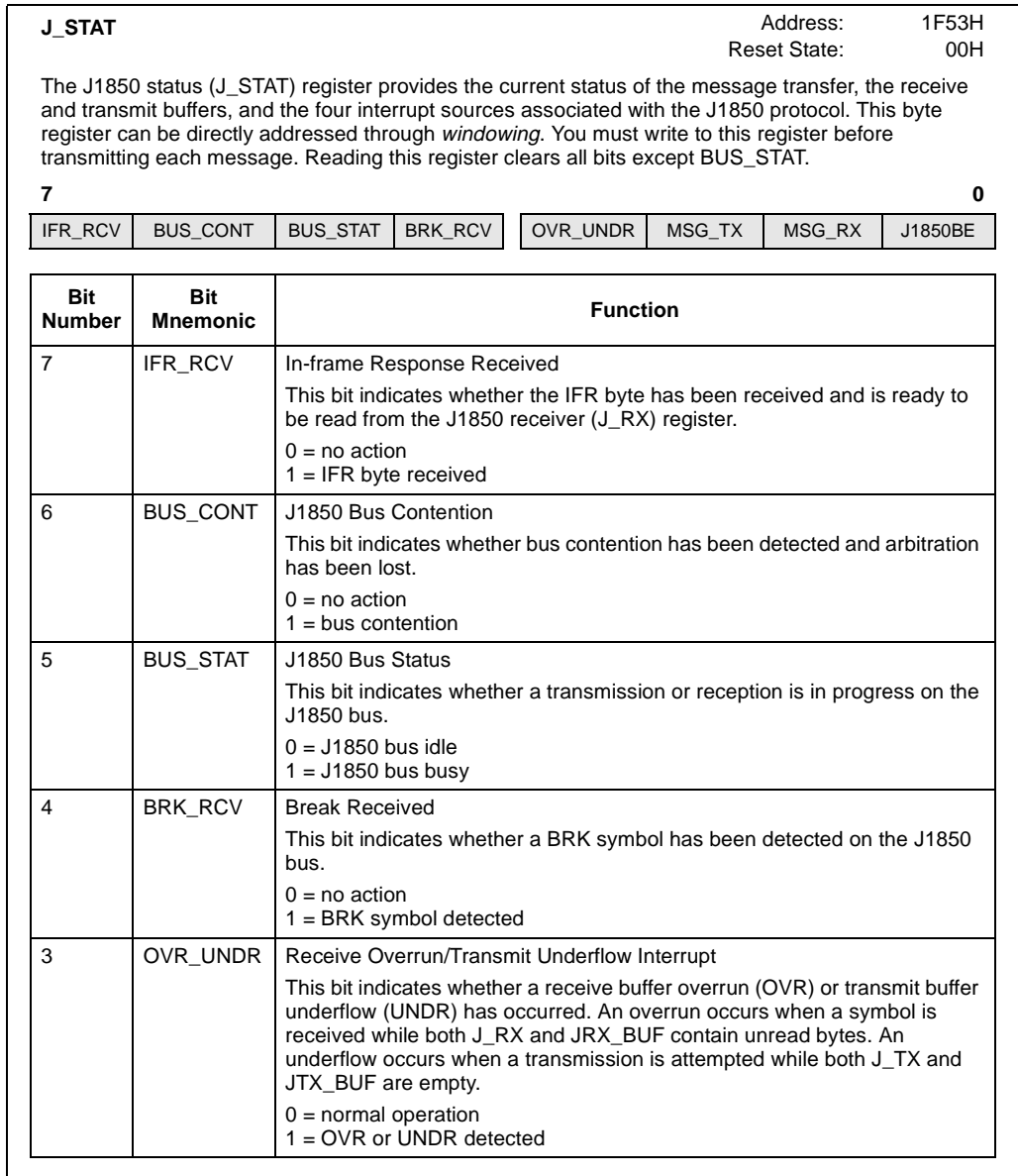

**Figure 8-19. J1850 Status (J\_STAT) Register**

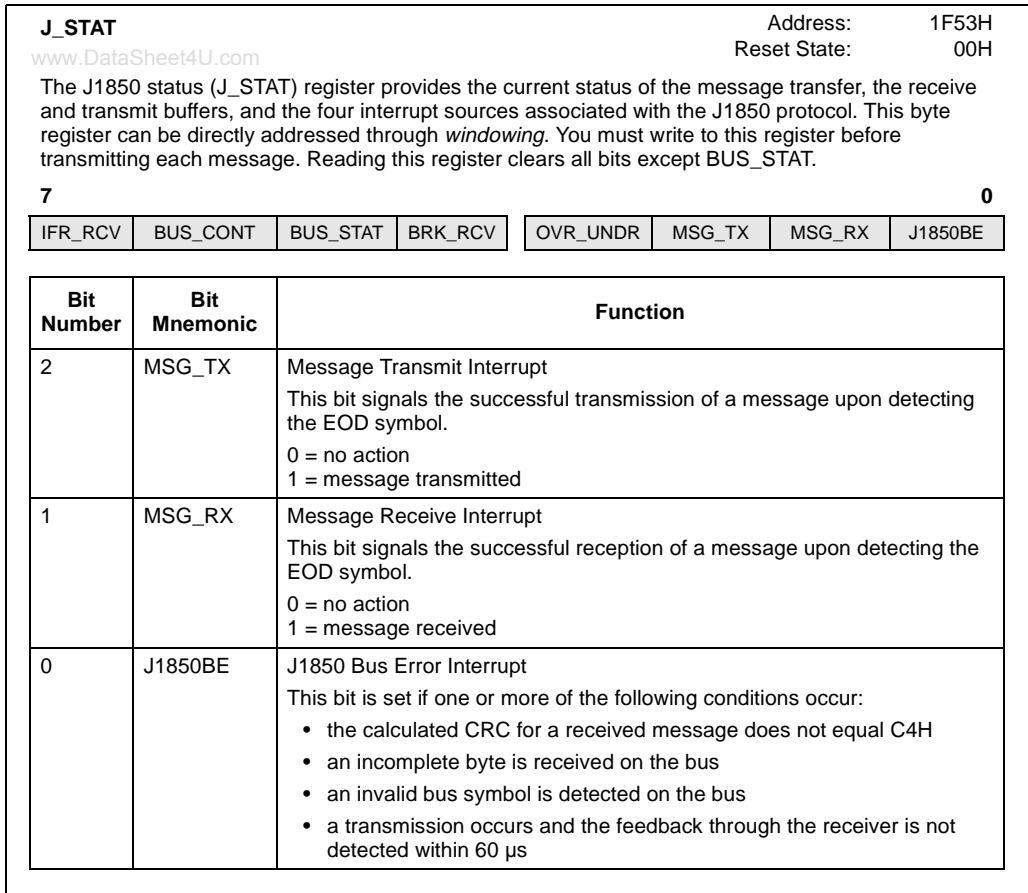

**Figure 8-19. J1850 Status (J\_STAT) Register (Continued)**



# Minimum Hardware Considerations



This chapter discusses the major hardware consideration differences between the 8XC196Lx and the 8XC196Kx. The 8XC196Lx has implemented a reset source SFR that reveals the source of the most recent reset request.

### 9.1 IDENTIFYING THE RESET SOURCE

The reset source (RSTSRC) register indicates the source of the last reset that the microcontroller encountered (Figure 9-1). If more than one reset occurs at the same time, all of the corresponding RSTSRC bits are set. Reading this SFR clears all the register bits.

| <b>RSTSRC</b>   |              | Address: 1F92H  |
|---|--------------|---|
|   |              | Reset State: XXH <sup>(1)</sup>   |
| The reset source (RSTSRC) register indicates the source(s) of the last reset that the microcontroller encountered.  |              |   |
| 7   |              | 0   |
| —   | —            | —   |
| —   | —            | —   |
|   | CFDRST       | WDTRST  |
|   | SFWRST       | EXTRST  |
| Bit Number  | Bit Mnemonic | Function  |
| 7:4   | —            | Reserved; for compatibility with future devices, write zeros to these bits.   |
| 3   | CFDRST       | Clock Failure Detection Reset<br>When set, this bit indicates that a failed clock caused the last reset.  |
| 2   | WDTRST       | Watchdog Timer Reset<br>When set, this bit indicates that the watchdog timer caused the last reset.   |
| 1   | SFWRST       | Software Reset<br>When set, this bit indicates that either the RST instruction or the IDLPD instruction used with an illegal key caused the last reset. |
| 0   | EXTRST       | External Reset<br>When set, this bit indicates that the RESET# pin being asserted caused the last reset.  |
| <b>NOTE:</b>  |              |   |
| 1. The State of the RSTSRC register is indeterminate on a V <sub>CC</sub> power up condition. All other reset states will have the corresponding reset event bit set in the register. |              |   |

**Figure 9-1. Reset Source (RSTSRC) Register**

## 9.2 DESIGN CONSIDERATIONS FOR 8XC196LA, LB, AND LD

With the exception of a few new multiplexed functions, the 8XC196Lx microcontrollers are pin compatible with the 8XC196Jx microcontrollers. The 8XC196Jx microcontrollers are 52-lead versions of 8XC196Kx microcontrollers.

Follow these recommendations to help maintain hardware and software compatibility between the 8XC196Lx, 8XC196Kx, and future microcontrollers.

- **Bus width.** Since the 8XC196Lx has neither a WRH# nor a BUSWIDTH pin, the microcontroller cannot dynamically switch between 8- and 16-bit bus widths. Program the CCBs to select 8-bit bus mode.
- **Wait states.** Since the 8XC196Lx has no READY pin, the microcontroller cannot rely on a READY signal to control wait states. Program the CCBs to limit the number of wait states (0, 1, 2, or 3).
- **EPA6–EPA7.** These functions exist in the 8XC196Lx, but the associated pins are omitted. You can use these functions as software timers, to start A/D conversions (on 87C196LA and LB only), or to reset the timers.
- **Slave port.** Since the 8XC196Lx has no P5.1/SLPCS and P5.4/SLPINT pins, you cannot use the slave port.
- **ONCE mode.** On the 8XC196Lx, the ONCE mode entry function is multiplexed with P2.6 (and TXJ1850 on the 87C196LB) rather than with P5.4 as it is on the 8XC196Kx (P5.4/SLPINT/ONCE).
- **NMI.** Since the 8XC196Lx has no NMI pin, the nonmaskable interrupt is not supported. Initialize the NMI vector (at location 203EH) to point to a RET instruction. This method provides glitch protection only.
- **I/O ports.** The following port pins do not exist in the 8XC196Lx: P0.0–P0.1, P1.4–P1.7, P2.3 and P2.5, P5.1 and P5.4–P5.7, P6.2 and P6.3. Software can still read and write the associated Px\_REG, Px\_MODE, and Px\_DIR registers. Configure the registers for the omitted pins as follows:
  - Clear the corresponding Px\_DIR bits. (Configures pins as complementary outputs.)
  - Clear the corresponding Px\_MODE bits. (Selects I/O port function.)
  - Write either “0” or “1” to the corresponding Px\_REG bits. (Effectively ties signals low or high.)

Do not use the bits associated with the omitted port pins for conditional branch instructions. Treat these bits as reserved.
- **Auto programming.** During auto programming, the 8XC196Lx supports only a 16-bit, zero-wait-state bus configuration.

## Special Operating Modes



## CHAPTER 10

# SPECIAL OPERATING MODES

The 8XC196Lx's idle and powerdown modes are the same as those of the 8XC196Kx. However, the clock circuitry has changed, and the on-circuit emulation (ONCE) special-purpose mode operation has changed slightly because of the new reset state pin levels that have been implemented.

### 10.1 INTERNAL TIMING

The 87C196LA and LB clock circuitry (Figure 10-1) implements a phase-locked loop and clock multiplier circuitry, which can substantially increase the CPU clock rate while using a lower-frequency input clock.

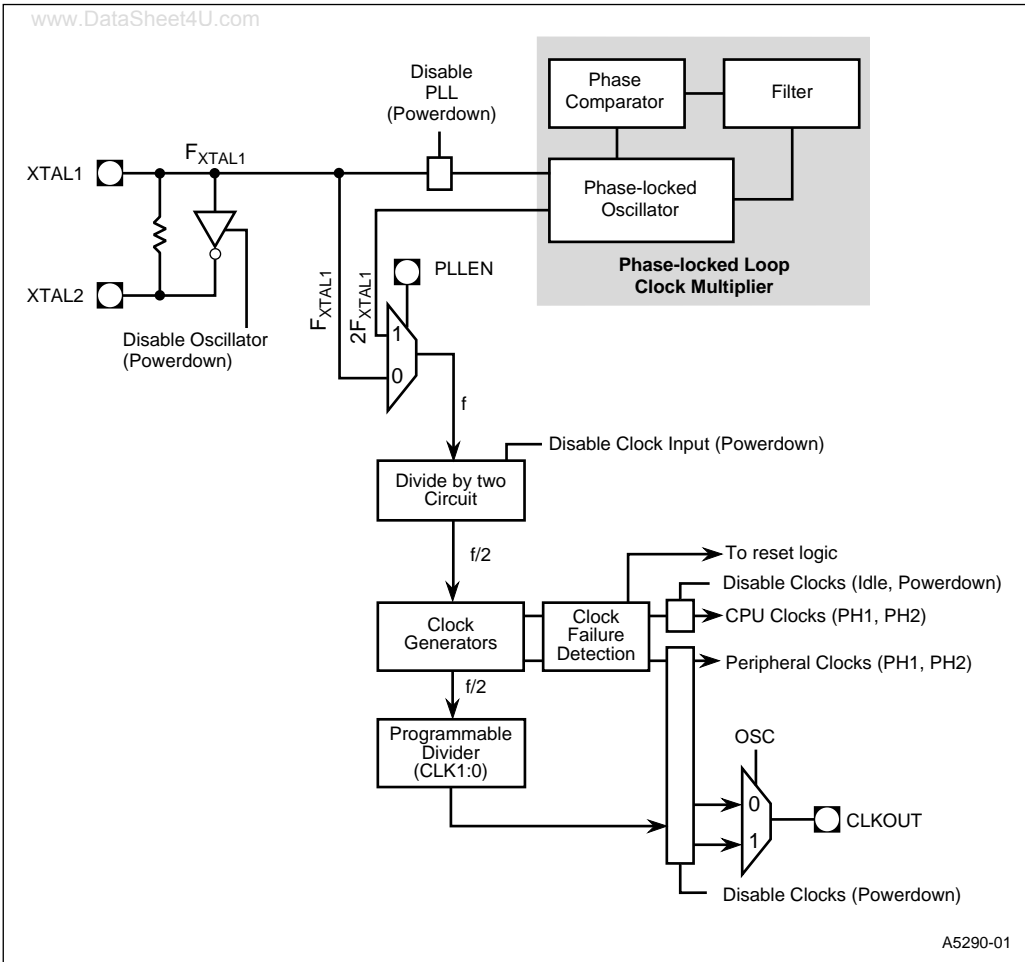

Figure 10-1. Clock Circuitry (87C196LA, LB Only)

## 10.2 ENTERING AND EXITING ONCE MODE

ONCE mode isolates the device from other components in the system to allow printed-circuit-board testing or debugging with a clip-on emulator. During ONCE mode, all pins except XTAL1, XTAL2,  $V_{SS}$ , and  $V_{CC}$  are weakly pulled either high or low. During ONCE mode, RESET# must be held high or the device will exit ONCE mode and enter the reset state.

On the 87C196LA and LB, the reset state level of all 41 general-purpose I/O pins has changed from a weak logic "1" (wk1) to a weak logic "0" (wk0). ONCE shares a package with port pin 2.6. Asserting and holding the ONCE signal high during the rising edge of RESET# causes the device to enter ONCE mode. To prevent accidental entry into ONCE mode, configure this pin as



an output. If you choose to configure this pin as an input, always hold it low during reset and ensure that your system meets the  $V_{IH}$  specification to prevent inadvertent entry into ONCE mode.

[www.DataSheet4U.com](http://www.DataSheet4U.com)



## Programming the Nonvolatile Memory



The 87C196LA and LB microcontrollers contain 24 Kbytes (2000–7FFFH) of one-time-programmable read-only memory (OTPROM). OTPROM is similar to EPROM, but it comes in a windowless package and cannot be erased. You have the option of programming the OTPROM yourself or having the factory program it as a quick-turn ROM product (the latter option may not be available for all devices).

### NOTE

In this supplement, OTPROM refers to the device’s internal read-only memory, whether it is EPROM or OTPROM, and EPROM refers specifically to EPROM devices.

The 87C196LA and LB programming signals, registers, and procedures are the same as those of the 87C196Kx. This chapter describes the differences in memory mapping and programming circuits for the 87C196LA and LB.

### 11.1 SIGNATURE WORD AND PROGRAMMING VOLTAGE VALUES

The 8XC196Lx’s programming voltage values are the same as those of the 8XC196Kx; however, the signature word value differs. Table 11-1 lists the signature word and programming voltage values.

**Table 11-1. Signature Word and Programming Voltage Values**

| Device   | Signature Word |       | Programming V <sub>CC</sub> |       | Programming V <sub>PP</sub> |       |
|----------|----------------|-------|-----------------------------|-------|-----------------------------|-------|
|          | Location       | Value | Location                    | Value | Location                    | Value |
| 87C196LA | 0070H          | 871BH | 0072H                       | 40H   | 0073H                       | 0A0H  |
| 87C196LB | 0070H          | 871BH | 0072H                       | 40H   | 0073H                       | 0A0H  |

### 11.2 OTPROM ADDRESS MAP

The OTPROM contains customer-specified special-purpose and program memory (Table 11-2). The 128-byte special-purpose address partition is used for interrupt vectors, the chip configuration bytes (CCBs), and the security key. Several locations are reserved for testing or for use in future products. Write the value (20H or FFH) indicated in Table 11-2 to each reserved location. The remainder of the OTPROM is available for code storage.

www.DataSheet4U.com **Table 11-2. 87C196LA, LB OTPROM Address Map**

| Address Range (Hex) | Description                                  |
|---------------------|--|
| 7FFF<br>2080        | Program memory                               |
| 207F<br>205E        | Reserved (each location must contain FFH)    |
| 205D<br>2040        | PTS vectors                                  |
| 203F<br>2030        | Upper interrupt vectors                      |
| 202F<br>2020        | Security key                                 |
| 201F<br>201C        | Reserved (each location must contain FFH)    |
| 201B                | Reserved (must contain 20H)                  |
| 201A                | CCB1   |
| 2019                | Reserved (must contain 20H)                  |
| 2018                | CCB0   |
| 2017<br>2016        | OFD flag for QROM or MROM codes <sup>†</sup> |
| 2015<br>2014        | Reserved (each location must contain FFH)    |
| 2013<br>2000        | Lower interrupt vectors                      |

<sup>†</sup> Intel manufacturing uses this location to determine whether to program the OFD bit. Customers with quick-ROM (QROM) or masked-ROM (MROM) codes who desire oscillator failure detection should equate this location to the value 0CDEH.

### 11.3 SLAVE PROGRAMMING CIRCUIT AND ADDRESS MAP

Figure 11-1 shows the circuit diagram and Table 11-3 details the address map for slave programming of the 87C196LA and LB devices.

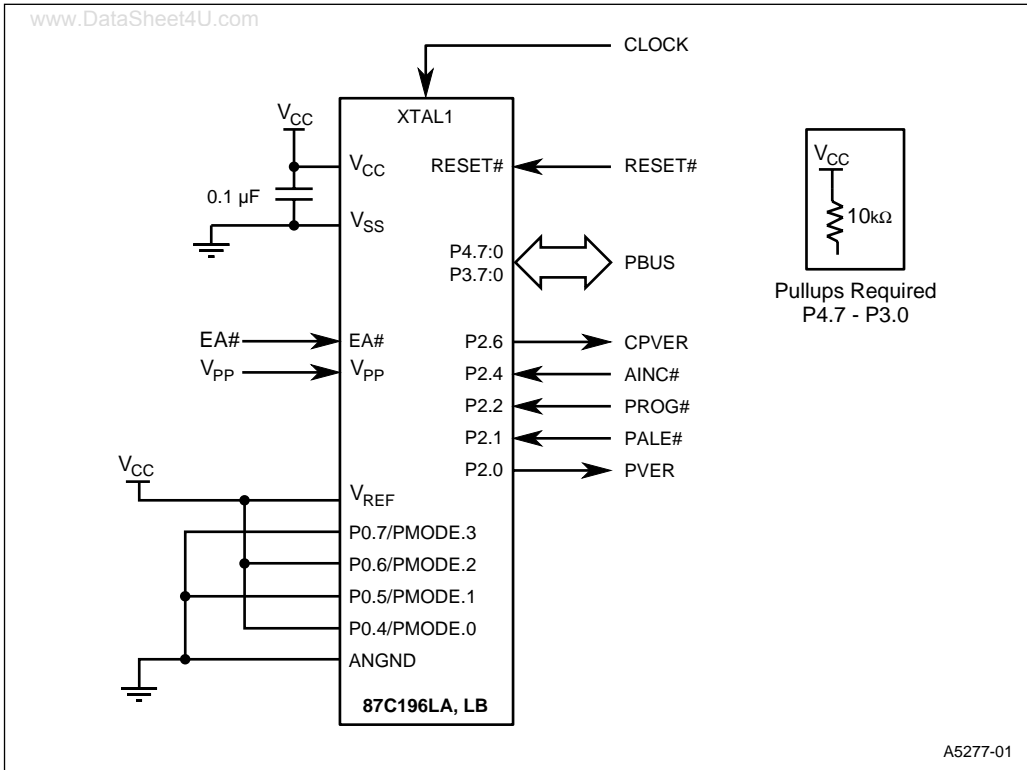

Figure 11-1. Slave Programming Circuit

Table 11-3. Slave Programming Mode Address Map

| Description                 | Address    | Comments     |
|-----------------------------|------------|--------------|
| OTPROM                      | 2000–7FFFH | OTPROM Cells |
| OFD                         | 0778H      | OTPROM Cell  |
| DED†                        | 0758H      | UPROM Cell   |
| DEI†                        | 0718H      | UPROM Cell   |
| PCCB                        | 0218H      | Test EPROM   |
| Programming V <sub>CC</sub> | 0072H      | Read Only    |
| Programming V <sub>PP</sub> | 0073H      | Read Only    |
| Signature word              | 0070H      | Read Only    |

†These bits program the UPROM cells. Once these bits are programmed, they cannot be erased, and dynamic failure analysis of the device is impossible.

### 11.4 SERIAL PORT PROGRAMMING CIRCUIT AND ADDRESS MAP

Figure 11-2 shows the circuit and Table 11-4 details the address map for serial port programming.

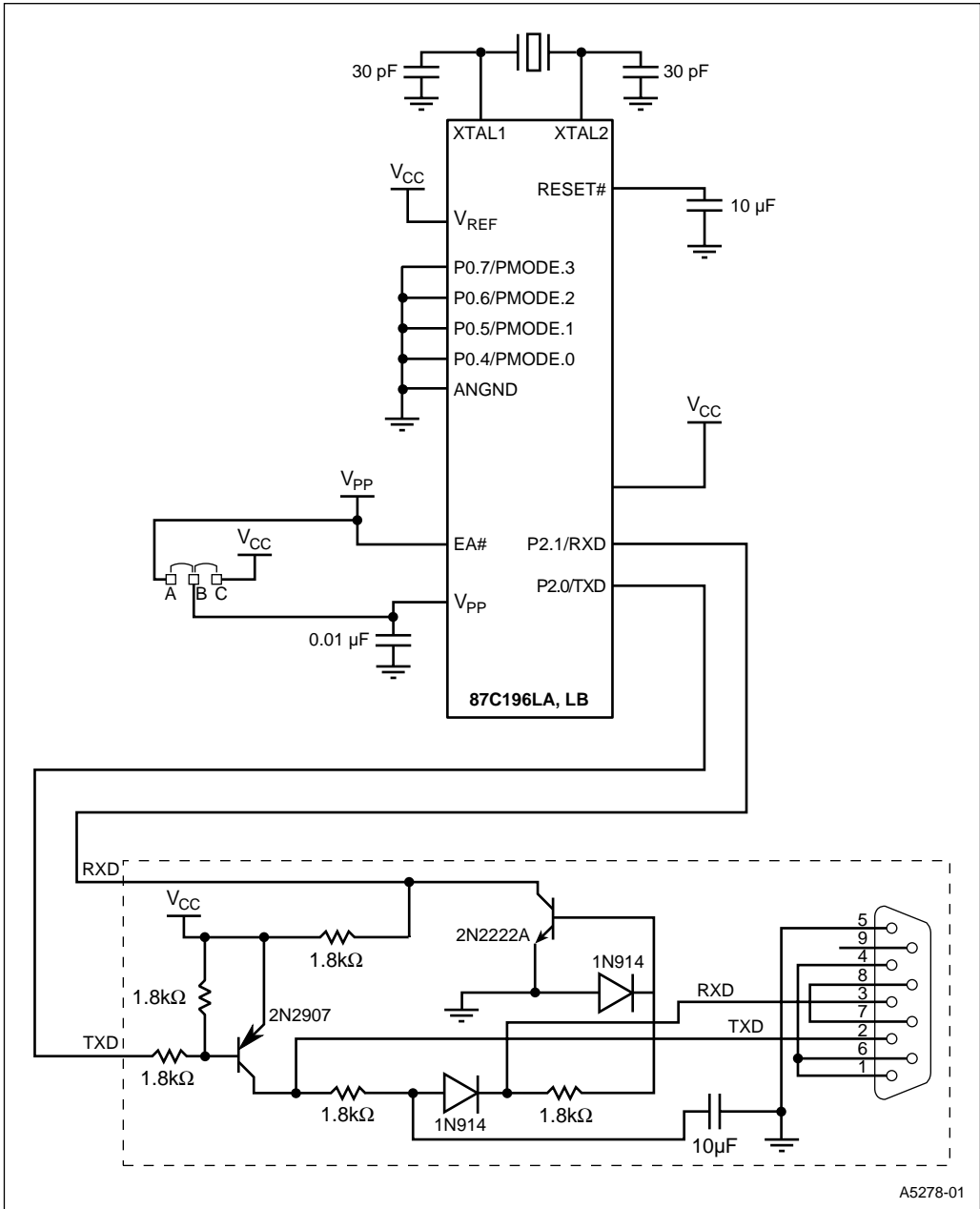

A5278-01

Figure 11-2. Serial Port Programming Circuit



**Table 11-4. Serial Port Programming Mode Address Map**

| <a href="http://www.DataSheet4U.com">www.DataSheet4U.com</a><br><b>Description</b> | <b>Address Range</b>    |                                     |
|--|-------------------------|-------------------------------------|
|  | <b>Normal Operation</b> | <b>Serial Port Programming Mode</b> |
| Internal OTPROM  | 2000–7FFFH              | A000–FFFFH                          |
| External memory  | —                       | 4000–9FFFH                          |
| <b>Do not address</b>  | —                       | 2400–3FFFH                          |
| Test ROM and RISM  | —                       | 2000–23FFFH                         |



# Signal Descriptions





# APPENDIX A

## SIGNAL DESCRIPTIONS

This appendix provides reference information for the pin functions of the 8XC196Lx microcontrollers.

### A.1 FUNCTIONAL GROUPINGS OF SIGNALS

Tables A-1, A-2, and A-3 list the signal assignments for the 8XC196Lx microcontrollers, grouped by function. A diagram of each microcontroller shows the pin location of each signal.

**Table A-1. 87C196LA Signals Arranged by Functional Categories**

| www.Addr & Data.com |     | Input/Output (Cont'd) |     | Program Control |     | Processor Control |     |
|---------------------|-----|-----------------------|-----|-----------------|-----|-------------------|-----|
| Name                | Pin | Name                  | Pin | Name            | Pin | Name              | Pin |
| AD0                 | 22  | P2.1 / RXD            | 28  | AINC#           | 30  | EA#               | 24  |
| AD1                 | 21  | P2.2                  | 29  | CPVER           | 31  | EXTINT            | 29  |
| AD2                 | 20  | P2.4                  | 30  | PACT#           | 32  | PLLEN             | 6   |
| AD3                 | 19  | P2.6                  | 31  | PALE#           | 28  | RESET#            | 23  |
| AD4                 | 18  | P2.7                  | 32  | PBUS.0          | 22  | XTAL1             | 52  |
| AD5                 | 17  | P3.0                  | 22  | PBUS.1          | 21  | XTAL2             | 51  |
| AD6                 | 16  | P3.1                  | 21  | PBUS.2          | 20  |                   |     |
| AD7                 | 15  | P3.2                  | 20  | PBUS.3          | 19  |                   |     |
| AD8                 | 14  | P3.3                  | 19  | PBUS.4          | 18  |                   |     |
| AD9                 | 13  | P3.4                  | 18  | PBUS.5          | 17  |                   |     |
| AD10                | 12  | P3.5                  | 17  | PBUS.6          | 16  |                   |     |
| AD11                | 11  | P3.6                  | 16  | PBUS.7          | 15  |                   |     |
| AD12                | 10  | P3.7                  | 15  | PBUS.8          | 14  |                   |     |
| AD13                | 9   | P4.0                  | 14  | PBUS.9          | 13  |                   |     |
| AD14                | 8   | P4.1                  | 13  | PBUS.10         | 12  |                   |     |
| AD15                | 7   | P4.2                  | 12  | PBUS.11         | 11  |                   |     |
|                     |     | P4.3                  | 11  | PBUS.12         | 10  |                   |     |
|                     |     | P4.4                  | 10  | PBUS.13         | 9   |                   |     |
|                     |     | P4.5                  | 9   | PBUS.14         | 8   |                   |     |
|                     |     | P4.6                  | 8   | PBUS.15         | 7   |                   |     |
|                     |     | P4.7                  | 7   | PMODE.0         | 35  |                   |     |
|                     |     | P5.0                  | 2   | PMODE.1         | 36  |                   |     |
|                     |     | P5.2                  | 6   | PMODE.2         | 37  |                   |     |
|                     |     | P5.3                  | 5   | PMODE.3         | 38  |                   |     |
|                     |     | P6.0 / EPA8 / COMP0   | 45  | PROG#           | 29  |                   |     |
|                     |     | P6.1 / EPA9 / COMP1   | 46  | PVER            | 27  |                   |     |
|                     |     | P6.4 / SC0            | 47  |                 |     |                   |     |
|                     |     | P6.5 / SD0            | 48  |                 |     |                   |     |
|                     |     | P6.6 / SC1            | 49  |                 |     |                   |     |
|                     |     | P6.7 / SD1            | 50  |                 |     |                   |     |

| Input/Output        |     |
|---------------------|-----|
| Name                | Pin |
| P0.2 / ACH2         | 33  |
| P0.3 / ACH3         | 34  |
| P0.4 / ACH4         | 35  |
| P0.5 / ACH5         | 36  |
| P0.6 / ACH6         | 37  |
| P0.7 / ACH7         | 38  |
| P1.0 / EPA0 / T2CLK | 44  |
| P1.1 / EPA1         | 43  |
| P1.2 / EPA2 / T2DIR | 42  |
| P1.3 / EPA3         | 41  |
| P2.0 / TXD          | 27  |

| Bus Cont & Status |     |
|-------------------|-----|
| Name              | Pin |
| ADV# / ALE        | 2   |
| CLKOUT            | 32  |
| RD#               | 5   |
| WR# / WRL#        | 6   |

| Power & Ground   |     |
|------------------|-----|
| Name             | Pin |
| ANGND            | 39  |
| V <sub>CC</sub>  | 26  |
| V <sub>PP</sub>  | 4   |
| V <sub>REF</sub> | 40  |
| V <sub>SS</sub>  | 3   |
| V <sub>SS1</sub> | 1   |
| V <sub>SS1</sub> | 25  |

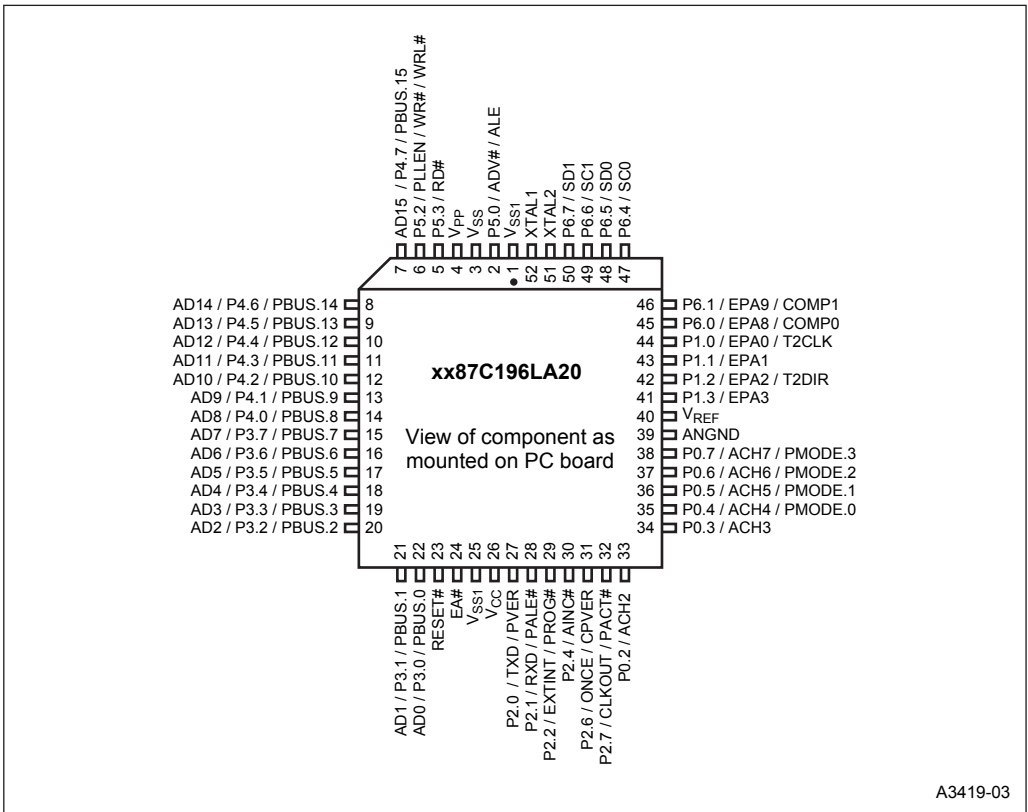

Figure A-1. 87C196LA 52-pin PLCC Package

Table A-2. 87C196LB Signals Arranged by Functional Categories

| www.Addr & Data.com |     | Input/Output (Cont'd) |     | Program Control |     | Processor Control |     |
|---------------------|-----|-----------------------|-----|-----------------|-----|-------------------|-----|
| Name                | Pin | Name                  | Pin | Name            | Pin | Name              | Pin |
| AD0                 | 22  | P2.1 / RXD            | 28  | AINC#           | 30  | EA#               | 24  |
| AD1                 | 21  | P2.2                  | 29  | CPVER           | 31  | EXTINT            | 29  |
| AD2                 | 20  | P2.4 / RXJ1850        | 30  | PACT#           | 32  | PLLEN             | 6   |
| AD3                 | 19  | P2.6 / TXJ1850        | 31  | PALE#           | 28  | RESET#            | 23  |
| AD4                 | 18  | P2.7                  | 32  | PBUS.0          | 22  | XTAL1             | 52  |
| AD5                 | 17  | P3.0                  | 22  | PBUS.1          | 21  | XTAL2             | 51  |
| AD6                 | 16  | P3.1                  | 21  | PBUS.2          | 20  |                   |     |
| AD7                 | 15  | P3.2                  | 20  | PBUS.3          | 19  |                   |     |
| AD8                 | 14  | P3.3                  | 19  | PBUS.4          | 18  |                   |     |
| AD9                 | 13  | P3.4                  | 18  | PBUS.5          | 17  |                   |     |
| AD10                | 12  | P3.5                  | 17  | PBUS.6          | 16  |                   |     |
| AD11                | 11  | P3.6                  | 16  | PBUS.7          | 15  |                   |     |
| AD12                | 10  | P3.7                  | 15  | PBUS.8          | 14  |                   |     |
| AD13                | 9   | P4.0                  | 14  | PBUS.9          | 13  |                   |     |
| AD14                | 8   | P4.1                  | 13  | PBUS.10         | 12  |                   |     |
| AD15                | 7   | P4.2                  | 12  | PBUS.11         | 11  |                   |     |
|                     |     | P4.3                  | 11  | PBUS.12         | 10  |                   |     |
|                     |     | P4.4                  | 10  | PBUS.13         | 9   |                   |     |
|                     |     | P4.5                  | 9   | PBUS.14         | 8   |                   |     |
|                     |     | P4.6                  | 8   | PBUS.15         | 7   |                   |     |
|                     |     | P4.7                  | 7   | PMODE.0         | 35  |                   |     |
|                     |     | P5.0                  | 2   | PMODE.1         | 36  |                   |     |
|                     |     | P5.2                  | 6   | PMODE.2         | 37  |                   |     |
|                     |     | P5.3                  | 5   | PMODE.3         | 38  |                   |     |
|                     |     | P6.0 / EPA8 / COMP0   | 45  | PROG#           | 29  |                   |     |
|                     |     | P6.1 / EPA9 / COMP1   | 46  | PVER            | 27  |                   |     |
|                     |     | P6.4 / SC0            | 47  |                 |     |                   |     |
|                     |     | P6.5 / SD0            | 48  |                 |     |                   |     |
|                     |     | P6.6 / SC1            | 49  |                 |     |                   |     |
|                     |     | P6.7 / SD1            | 50  |                 |     |                   |     |

| Input/Output        |     |
|---------------------|-----|
| Name                | Pin |
| P0.2 / ACH2         | 33  |
| P0.3 / ACH3         | 34  |
| P0.4 / ACH4         | 35  |
| P0.5 / ACH5         | 36  |
| P0.6 / ACH6         | 37  |
| P0.7 / ACH7         | 38  |
| P1.0 / EPA0 / T2CLK | 44  |
| P1.1 / EPA1         | 43  |
| P1.2 / EPA2 / T2DIR | 42  |
| P1.3 / EPA3         | 41  |
| P2.0 / TXD          | 27  |

  

| Bus Cont & Status |     |
|-------------------|-----|
| Name              | Pin |
| ADV# / ALE        | 2   |
| CLKOUT            | 32  |
| RD#               | 5   |
| WR# / WRL#        | 6   |

| Power & Ground   |     |
|------------------|-----|
| Name             | Pin |
| ANGND            | 39  |
| V <sub>CC</sub>  | 26  |
| V <sub>PP</sub>  | 4   |
| V <sub>REF</sub> | 40  |
| V <sub>SS</sub>  | 3   |
| V <sub>SS1</sub> | 1   |
| V <sub>SS1</sub> | 25  |



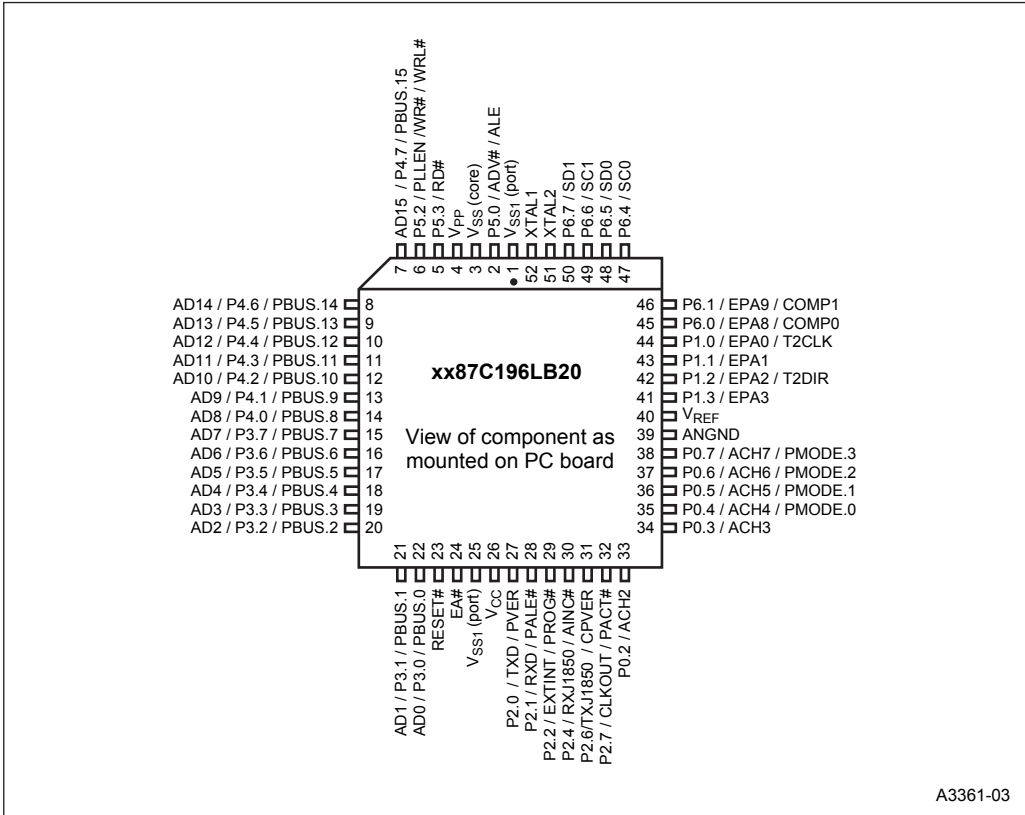

A3361-03

Figure A-2. 87C196LB 52-pin PLCC Package



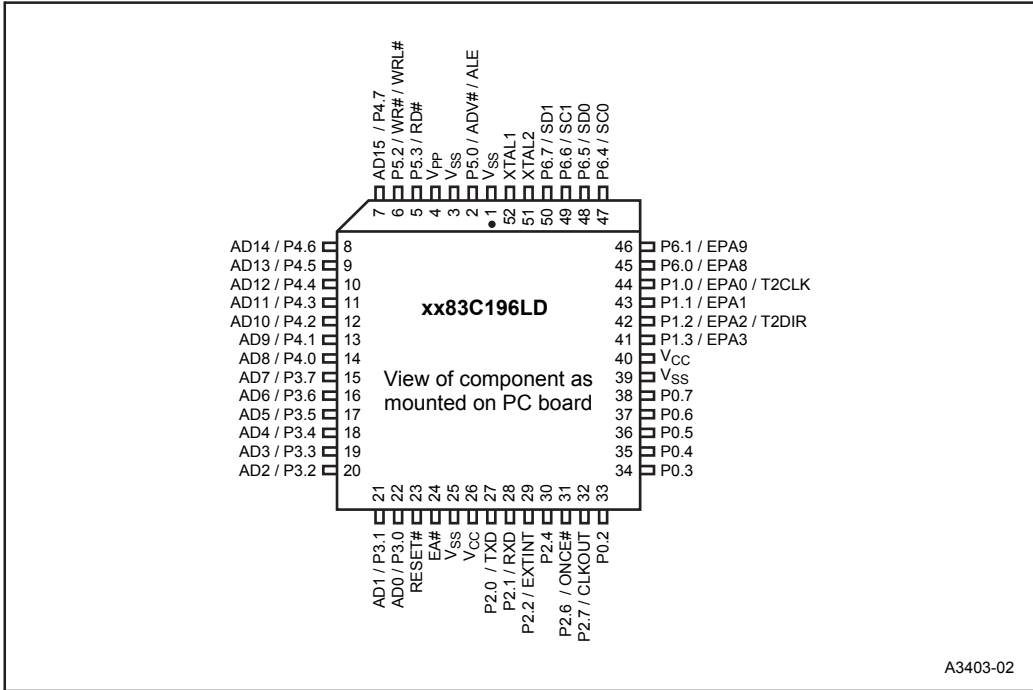

**Figure A-3. 83C196LD 52-pin PLCC Package**

## A.2 DEFAULT CONDITIONS

Table A-5 lists the values of the signals for the 87C196LA and 87C196LB during various operating conditions. Table A-6 lists the same information for the 83C196LD. Table A-4 defines the symbols used to represent the pin status. Refer to the DC characteristics table in the datasheet for actual specifications for  $V_{OL}$ ,  $V_{IL}$ ,  $V_{OH}$ , and  $V_{IH}$ .

**Table A-4. Definition of Status Symbols**

| Symbol | Definition   | Symbol | Definition       |
|--------|--|--------|------------------|
| 0      | Voltage less than or equal to $V_{OL}$ , $V_{IL}$    | MD0    | Medium pull-down |
| 1      | Voltage greater than or equal to $V_{OH}$ , $V_{IH}$ | MD1    | Medium pull-up   |
| HiZ    | High impedance                                       | WK0    | Weak pull-down   |
| LoZ0   | Low impedance; strongly driven low                   | WK1    | Weak pull-up     |
| LoZ1   | Low impedance; strongly driven high                  | ODIO   | Open-drain I/O   |

[www.DataSheet4U.com](http://www.DataSheet4U.com) **Table A-5. 87C196LA, LB Default Signal Conditions**

| Port Signals | Alternate Functions    | During RESET# Active  | Upon RESET# Inactive (Note 6) | Idle               | Power-down     |
|--------------|------------------------|-----------------------|-------------------------------|--------------------|----------------|
| P0.7:2       | ACH7:2                 | HiZ                   | HiZ                           | HiZ                | HiZ            |
| P1.0         | EPA0/T2CLK             | WK0                   | WK0                           | (Note 1)           | (Note 1)       |
| P1.1         | EPA1                   | WK0                   | WK0                           | (Note 1)           | (Note 1)       |
| P1.2         | EPA2/T2DIR             | WK0                   | WK0                           | (Note 1)           | (Note 1)       |
| P1.3         | EPA3                   | WK0                   | WK0                           | (Note 1)           | (Note 1)       |
| P2.0         | TXD                    | WK0                   | WK0                           | (Note 1)           | (Note 1)       |
| P2.1         | RXD                    | WK0                   | WK0                           | (Note 1)           | (Note 1)       |
| P2.2         | EXTINT                 | WK0                   | WK0                           | (Note 1)           | (Note 1)       |
| P2.4         | RXJ1850 (LB only)      | WK0                   | WK0                           | (Note 1)           | (Note 1)       |
| P2.6         | ONCE/TXJ1850 (LB only) | MD0                   | MD0                           | (Note 1)           | (Note 1)       |
| P2.7         | CLKOUT                 | CLKOUT active, LoZ0/1 | CLKOUT active, LoZ0/1         | (Note 1)           | (Note 2)       |
| P3.7:0       | AD7:0                  | WK0                   | HiZ                           | (Note 4)           | (Note 4)       |
| P4.7:0       | AD15:8                 | WK0                   | HiZ                           | (Note 4)           | (Note 4)       |
| P5.0         | ALE/ADV#               | WK0                   | WK0                           | (Note 1)           | (Note 1)       |
| P5.2         | WR#/WRL#               | WK0                   | WK0                           | (Note 1)           | (Note 1)       |
| P5.3         | RD#                    | WK0                   | WK0                           | (Note 1)           | (Note 1)       |
| P6.0         | EPA8/COMP0             | WK0                   | WK0                           | (Note 1)           | (Note 1)       |
| P6.1         | EPA9/COMP1             | WK0                   | WK0                           | (Note 1)           | (Note 1)       |
| P6.4         | SC0                    | WK0                   | WK0                           | (Note 1)           | (Note 1)       |
| P6.5         | SD0                    | WK0                   | WK0                           | (Note 1)           | (Note 1)       |
| P6.6         | SC1                    | WK0                   | WK0                           | (Note 1)           | (Note 1)       |
| P6.7         | SD1                    | WK0                   | WK0                           | (Note 1)           | (Note 1)       |
| —            | EA#                    | WK1 (Note 5)          | WK1                           | WK1                | WK1            |
| —            | RESET#                 | LoZ0                  | MD1                           | MD1                | MD1            |
| —            | V <sub>PP</sub>        | HiZ                   | HiZ                           | LoZ1               | LoZ1           |
| —            | XTAL1                  | Osc input, HiZ        | Osc input, HiZ                | Osc input, HiZ     | Osc input, HiZ |
| —            | XTAL2                  | Osc output, LoZ0/1    | Osc output, LoZ0/1            | Osc output, LoZ0/1 | (Note 3)       |

**NOTES:**

1. If P<sub>x</sub>\_MODE.y = 0, port is as programmed.  
If P<sub>x</sub>\_MODE.y = 1, pin is as specified by P<sub>x</sub>\_DIR and the associated peripheral.
2. If P2\_MODE.7 = 0, pin is as programmed. If P2\_MODE.7 = 1, pin is LoZ0.
3. If XTAL1 = 0, pin is LoZ1. If XTAL1 = 1, pin is LoZ0.
4. If EA# = 0, port is HiZ. If EA# = 1, port is open-drain I/O.
5. Although EA# is weakly pulled high, do not allow it to float. Always tie EA# to V<sub>CC</sub> if it is not connected to an external device.
6. The values in this column are valid until your software writes to P<sub>x</sub>\_MODE.

[www.DataSheet4U.com](http://www.DataSheet4U.com) **Table A-6. 83C196LD Default Signal Conditions**

| Port Signals | Alternate Functions | During RESET# Active  | Upon RESET# Inactive (Note 6) | Idle               | Power-down     |
|--------------|---------------------|-----------------------|-------------------------------|--------------------|----------------|
| P0.7:2       | —                   | HiZ                   | HiZ                           | HiZ                | HiZ            |
| P1.0         | EPA0/T2CLK          | WK1                   | WK1                           | (Note 1)           | (Note 1)       |
| P1.1         | EPA1                | WK1                   | WK1                           | (Note 1)           | (Note 1)       |
| P1.2         | EPA2/T2DIR          | WK1                   | WK1                           | (Note 1)           | (Note 1)       |
| P1.3         | EPA3                | WK1                   | WK1                           | (Note 1)           | (Note 1)       |
| P2.0         | TXD                 | WK1                   | WK1                           | (Note 1)           | (Note 1)       |
| P2.1         | RXD                 | WK1                   | WK1                           | (Note 1)           | (Note 1)       |
| P2.2         | EXTINT              | WK1                   | WK1                           | (Note 1)           | (Note 1)       |
| P2.4         | —                   | WK1                   | WK1                           | (Note 1)           | (Note 1)       |
| P2.6         | ONCE                | MD1                   | MD1                           | (Note 1)           | (Note 1)       |
| P2.7         | CLKOUT              | CLKOUT active, LoZ0/1 | CLKOUT active, LoZ0/1         | (Note 1)           | (Note 2)       |
| P3.7:0       | AD7:0               | WK1                   | HiZ                           | (Note 4)           | (Note 4)       |
| P4.7:0       | AD15:8              | WK1                   | HiZ                           | (Note 4)           | (Note 4)       |
| P5.0         | ALE/ADV#            | WK1                   | WK1                           | (Note 1)           | (Note 1)       |
| P5.2         | WR#/WRL#            | WK1                   | WK1                           | (Note 1)           | (Note 1)       |
| P5.3         | RD#                 | WK1                   | WK1                           | (Note 1)           | (Note 1)       |
| P6.0         | EPA8                | WK1                   | WK1                           | (Note 1)           | (Note 1)       |
| P6.1         | EPA9                | WK1                   | WK1                           | (Note 1)           | (Note 1)       |
| P6.4         | SC0                 | WK1                   | WK1                           | (Note 1)           | (Note 1)       |
| P6.5         | SD0                 | WK1                   | WK1                           | (Note 1)           | (Note 1)       |
| P6.6         | SC1                 | WK1                   | WK1                           | (Note 1)           | (Note 1)       |
| P6.7         | SD1                 | WK1                   | WK1                           | (Note 1)           | (Note 1)       |
| —            | EA#                 | WK1 (Note 5)          | WK1                           | WK1                | WK1            |
| —            | RESET#              | LoZ0                  | MD1                           | MD1                | MD1            |
| —            | V <sub>PP</sub>     | HiZ                   | HiZ                           | LoZ1               | LoZ1           |
| —            | XTAL1               | Osc input, HiZ        | Osc input, HiZ                | Osc input, HiZ     | Osc input, HiZ |
| —            | XTAL2               | Osc output, LoZ0/1    | Osc output, LoZ0/1            | Osc output, LoZ0/1 | (Note 3)       |

**NOTES:**

1. If P<sub>x</sub>\_MODE.<sub>y</sub> = 0, port is as programmed.  
If P<sub>x</sub>\_MODE.<sub>y</sub> = 1, pin is as specified by P<sub>x</sub>\_DIR and the associated peripheral.
2. If P2\_MODE.7 = 0, pin is as programmed. If P2\_MODE.7 = 1, pin is LoZ0.
3. If XTAL1 = 0, pin is LoZ1. If XTAL1 = 1, pin is LoZ0.
4. If EA# = 0, port is HiZ. If EA# = 1, port is open-drain I/O.
5. Although EA# is weakly pulled high, do not allow it to float. Always tie EA# to V<sub>CC</sub> if it is not connected to an external device.
6. The values in this column are valid until your software writes to P<sub>x</sub>\_MODE.



# Glossary





# GLOSSARY

This glossary defines acronyms, abbreviations, and terms that have special meaning in this manual. (Chapter 1 discusses notational conventions and general terminology.)

|                              |   |
|------------------------------|---|
| <b>absolute error</b>        | The maximum difference between corresponding actual and ideal <i>code transitions</i> . Absolute error accounts for all deviations of an actual A/D converter from an ideal converter.  |
| <b>accumulator</b>           | A register or storage location that forms the result of an arithmetic or logical operation.   |
| <b>actual characteristic</b> | A graph of output code versus input voltage of an actual <i>A/D converter</i> . An actual characteristic may vary with temperature, supply voltage, and frequency conditions.   |
| <b>A/D converter</b>         | Analog-to-digital converter. An internal peripheral that converts an analog input to a digital value.   |
| <b>ALU</b>                   | Arithmetic-logic unit. The part of the <i>RALU</i> that processes arithmetic and logical operations.  |
| <b>assert</b>                | The act of making a signal active (enabled). The polarity (high or low) is defined by the signal name. Active-low signals are designated by a pound symbol (#) suffix; active-high signals have no suffix. To assert RD# is to drive it low; to assert ALE is to drive it high. |
| <b>attenuation</b>           | A decrease in amplitude; voltage decay.   |
| <b>bit</b>                   | A binary digit.   |
| <b>BIT</b>                   | A single-bit operand that can take on the Boolean values, “true” and “false.”   |
| <b>bit arbitration</b>       | The process of settling conflicts that occur when multiple nodes attempt to transmit a bit or symbol across a single bus at the same time.  |
| <b>break-before-make</b>     | The property of a multiplexer which guarantees that a previously selected channel is deselected before a new channel is selected. (That is, break-before-make ensures that the <i>A/D converter</i> will not short inputs together.)  |

|  |  |
|--|--|
| <b>byte</b>                                | Any 8-bit unit of data.  |
| <b>BYTE</b> <small>DataSheet4U.com</small> | An unsigned, 8-bit variable with values from 0 through $2^8-1$ .   |
| <b>CCBs</b>                                | Chip configuration bytes. The chip configuration registers ( <i>CCRs</i> ) are loaded with the contents of the CCBs after a reset.   |
| <b>CCRs</b>                                | Chip configuration registers. Registers that define the environment in which the microcontroller will be operating. The chip configuration registers are loaded with the contents of the <i>CCBs</i> after a reset.  |
| <b>channel-to-channel matching error</b>   | The difference between corresponding <i>code transitions</i> of actual characteristics taken from different <i>A/D converter</i> channels under the same temperature, voltage, and frequency conditions. This error is caused by differences in <i>DC input leakage</i> and on-channel resistance from one multiplexer channel to another. |
| <b>characteristic</b>                      | A graph of output code versus input voltage; the <i>transfer function</i> of an <i>A/D converter</i> .   |
| <b>chip-select unit</b>                    | The integrated module that selects an external memory device during an external bus cycle.   |
| <b>clear</b>                               | The “0” value of a bit or the act of giving it a “0” value. See also <i>set</i> .  |
| <b>code</b>                                | 1) A set of instructions that perform a specific function; a program.<br>2) The digital value output by the <i>A/D converter</i> .   |
| <b>code center</b>                         | The voltage corresponding to the midpoint between two adjacent <i>code transitions</i> on the <i>A/D converter</i> .   |
| <b>code transition</b>                     | The point at which the <i>A/D converter</i> ’s output code changes from “Q” to “Q+1.” The input voltage corresponding to a code transition is defined as the voltage that is equally likely to produce either of two adjacent codes.   |
| <b>code width</b>                          | The voltage change corresponding to the difference between two adjacent <i>code transitions</i> . Code width deviations cause <i>differential nonlinearity</i> and <i>nonlinearity</i> errors.   |

|  |   |
|--|---|
| <b>contention</b>  | The detection of conflicting symbols or bits on the bus.  |
| <a href="http://www.DataSheet4U.com">www.DataSheet4U.com</a> |   |
| <b>crosstalk</b>   | See <i>off-isolation</i> .  |
| <b>DC input leakage</b>                                      | Leakage current from an analog input pin to ground or to the reference voltage ( $V_{REF}$ ).   |
| <b>deassert</b>  | The act of making a signal inactive (disabled). The polarity (high or low) is defined by the signal name. Active-low signals are designated by a pound symbol (#) suffix; active-high signals have no suffix. To deassert RD# is to drive it high; to deassert ALE is to drive it low.  |
| <b>demultiplexed bus</b>                                     | The configuration in which the microcontroller uses separate lines for address and data (address on A20:0; data on AD15:0 for a 16-bit bus or AD7:0 for an 8-bit bus). See also <i>multiplexed bus</i> .  |
| <b>differential nonlinearity</b>                             | The difference between the actual <i>code width</i> and the ideal one-LSB code width of the <i>terminal-based characteristic</i> of an A/D converter. It provides a measure of how much the input voltage may have changed in order to produce a one-count change in the conversion result. <i>Differential nonlinearity</i> is a measure of local code-width error; <i>nonlinearity</i> is a measure of overall code-transition error. |
| <b>doping</b>  | The process of introducing a periodic table Group III or Group V element into a Group IV element (e.g., silicon). A Group III impurity (e.g., indium or gallium) results in a <i>p-type material</i> . A Group V impurity (e.g., arsenic or antimony) results in an <i>n-type material</i> .  |
| <b>double-word</b>   | Any 32-bit unit of data.  |
| <b>DOUBLE-WORD</b>   | An unsigned, 32-bit variable with values from 0 through $2^{32}-1$ .  |
| <b>EPA</b>   | Event processor array. An integrated peripheral that provides high-speed input/output capability.   |
| <b>ESD</b>   | Electrostatic discharge.  |

|  |  |
|--|--|
| <b>external address</b>                                      | A 21-bit address is presented on the microcontroller's pins. The address decoded by an external device depends on how many of these address pins the external system uses. See also <i>internal address</i> .  |
| <a href="http://www.DataSheet4U.com">www.DataSheet4U.com</a> |  |
| <b>f</b>   | Lowercase "f" represents the frequency of the internal clock.  |
| <b>far constants</b>   | Constants that can be accessed only with extended instructions. See also <i>near constants</i> .   |
| <b>far data</b>  | Data that can be accessed only with extended instructions. See also <i>near data</i> .   |
| <b>feedthrough</b>   | The <i>attenuation</i> from an input voltage on the selected channel to the A/D output after the <i>sample window</i> closes. The ability of the <i>A/D converter</i> to reject an input on its selected channel after the sample window closes.   |
| <b>FET</b>   | Field-effect transistor.   |
| <b>full-scale error</b>                                      | The difference between the ideal and actual input voltage corresponding to the final (full-scale) <i>code transition</i> of an <i>A/D converter</i> .  |
| <b>hold latency</b>  | The time it takes the microcontroller to assert HLDA# after an external device asserts HOLD#.  |
| <b>ideal characteristic</b>                                  | The <i>characteristic</i> of an ideal <i>A/D converter</i> . An ideal characteristic is unique: its first <i>code transition</i> occurs when the input voltage is 0.5 LSB, its full-scale (final) code transition occurs when the input voltage is 1.5 LSB less than the full-scale reference, and its code widths are all exactly 1.0 LSB. These properties result in a conversion without <i>zero-offset</i> , <i>full-scale</i> , or <i>linearity</i> errors. <i>Quantizing error</i> is the only error seen in an ideal A/D converter. |
| <b>input leakage</b>   | Current leakage from an input pin to power or ground.  |
| <b>input series resistance</b>                               | The effective series resistance from an analog input pin to the <i>sample capacitor</i> of an <i>A/D converter</i> .   |
| <b>integer</b>   | Any member of the set consisting of the positive and negative whole numbers and zero.  |
| <b>INTEGER</b>   | A 16-bit, signed variable with values from $-2^{15}$ through $+2^{15}-1$ .   |

**internal address**

[www.DataSheet4U.com](http://www.DataSheet4U.com)

The 24-bit address that the microcontroller generates. See also *external address*.

**interrupt controller**

The module responsible for handling interrupts that are to be serviced by *interrupt service routines* that you provide. Also called the *programmable interrupt controller (PIC)*.

**interrupt latency**

The total delay between the time that an interrupt is generated (not acknowledged) and the time that the microcontroller begins executing the *interrupt service routine* or *PTS routine*. Determine the instruction in your code that has the longest execution time and use that execution time in calculating interrupt latency.

**interrupt service routine**

A software routine that you provide to service a standard interrupt request.

**interrupt vector**

A location in *special-purpose memory* that holds the starting address of an *interrupt service routine*.

**J1850**

An integrated communications controller peripheral that supports the 10.4 Kb/s *variable pulse-width (VPW)* medium-speed, class B, in-vehicle network protocol.

**ISR**

See *interrupt service routine*.

**linearity errors**

See *differential nonlinearity* and *nonlinearity*.

**LONG-INTEGER**

A 32-bit, signed variable with values from  $-2^{31}$  through  $+2^{31}-1$ .

**LSB**

- 1) Least-significant bit of a byte or least-significant byte of a word.
- 2) In an A/D converter, the reference voltage divided by  $2^n$ , where  $n$  is the number of bits to be converted. For a 10-bit converter with a reference voltage of 5.12 volts, one LSB is equal to 5.0 millivolts ( $5.12 \div 2^{10}$ ).

**LSW**

Least-significant word of a double-word or quad-word.

**maskable interrupts**

[www.DataSheet4U.com](http://www.DataSheet4U.com)

All interrupts except stack overflow, unimplemented opcode, and software trap. Maskable interrupts can be disabled (masked) by the individual mask bits in the interrupt mask registers, and their servicing can be disabled by the DI (disable interrupt service) instruction. Each *maskable interrupt* can be assigned to the *PTS* for processing.

**monotonic**

The property of *successive approximation* converters which guarantees that increasing input voltages produce adjacent *codes* of increasing value, and that decreasing input voltages produce adjacent codes of decreasing value. (In other words, a converter is monotonic if every code change represents an input voltage change in the same direction.) Large *differential nonlinearity* errors can cause the converter to exhibit nonmonotonic behavior.

**MSB**

Most-significant bit of a *byte* or most-significant byte of a *word*.

**MSW**

Most-significant word of a double-word or quad-word.

**multiplexed bus**

The configuration in which the microcontroller uses both A20:0 and AD15:0 for address and also uses AD15:0 for data. See also *demultiplexed bus*.

***n*-channel FET**

A field-effect transistor with an *n*-type conducting path (channel).

***n*-type material**

Semiconductor material with introduced impurities (*doping*) causing it to have an excess of negatively charged carriers.

**near constants**

Constants that can be accessed with nonextended instructions. Constants in page 00H are near constants. See also *far constants*.

**near data**

Data that can be accessed with nonextended instructions. Data in page 00H is near data. See also *far data*.

**no missing codes**

An A/D converter has *no missing codes* if, for every output code, there is a unique input voltage range which produces that code only. Large *differential nonlinearity* errors can cause the converter to miss codes.

**nonlinearity**

[www.DataSheet4U.com](http://www.DataSheet4U.com)

The maximum deviation of *code transitions* of the *terminal-based characteristic* from the corresponding code transitions of the *ideal characteristic*.

**nonmaskable interrupts**

Interrupts that cannot be masked (disabled) and cannot be assigned to the PTS for processing. The nonmaskable interrupts are stack overflow, unimplemented opcode, software trap, and NMI. The DI (disable interrupt service) and EI (enable interrupt service) instructions have no effect on nonmaskable interrupts.

**npn transistor**

A transistor consisting of one part *p-type material* and two parts *n-type material*.

**off-isolation**

The ability of an *A/D converter* to reject (isolate) the signal on a deselected (off) output.

**p-channel FET**

A field-effect transistor with a *p-type* conducting path.

**p-type material**

Semiconductor material with introduced impurities (*doping*) causing it to have an excess of positively charged carriers.

**PC**

Program counter.

**phase-locked loop**

A component of the clock generation circuitry. The phase-locked loop (PLL) and the input pin (PLEN) combine to enable the microcontroller to attain its maximum operating frequency with an external clock whose frequency is either equal to or one-half that maximum frequency or with an external oscillator whose frequency is one-half that maximum frequency.

**PIC**

Programmable interrupt controller. The module responsible for handling interrupts that are to be serviced by *interrupt service routines* that you provide. Also called simply the *interrupt controller*.

**PIH**

Peripheral interrupt handler. An integrated module that provides interrupt vectors for specific *EPA* interrupt requests to the *interrupt controller* or *PTS*.

**PLL**

See *phase-locked loop*.

**prioritized interrupt**

[www.DataSheet4U.com](http://www.DataSheet4U.com)

NMI, stack overflow, or any *maskable interrupt*. Two of the *nonmaskable interrupts* (unimplemented opcode and software trap) are not prioritized; they vector directly to the *interrupt service routine* when executed.

**program memory**

A partition of memory where instructions can be stored for fetching and execution.

**protected instruction**

An instruction that prevents an interrupt from being acknowledged until after the next instruction executes. The protected instructions are DI, EI, DPTS, EPTS, POPA, POPF, PUSHA, and PUSHF.

**PSW**

Processor status word. The high byte of the PSW is the status byte, which contains one bit that globally enables or disables servicing of all maskable interrupts, one bit that enables or disables the *PTS*, and six Boolean flags that reflect the state of the current program. The low byte of the PSW is the INT\_MASK register. A PUSHA or POPA instruction saves or restores both bytes (PSW + INT\_MASK); a PUSHF or POPF saves or restores only the PSW.

**PTS**

Peripheral transaction server. The microcoded hardware interrupt processor.

**PTSCB**

See *PTS control block*.

**PTS control block**

A block of data required for each *PTS interrupt*. The microcode executes the proper *PTS routine* based on the contents of the PTS control block.

**PTS cycle**

The microcoded response to a **single** PTS interrupt request.

**PTS interrupt**

Any *maskable interrupt* that is assigned to the *PTS* for interrupt processing.

**PTS mode**

A microcoded response that enables the *PTS* to complete a specific task quickly.

**PTS routine**

The entire microcoded response to multiple PTS interrupt requests. The PTS routine is controlled by the contents of the *PTS control block*.

**PTS transfer**

The movement of a single byte or word from the source memory location to the destination memory location.



**PTS vector**

[www.DataSheet4U.com](http://www.DataSheet4U.com)

**QUAD-WORD**

A location in *special-purpose memory* that holds the starting address of a *PTS control block*.

An unsigned, 64-bit variable with values from 0 through  $2^{64}-1$ . The QUAD-WORD variable is supported only as the operand for the EBMOVI instruction.

**quantizing error**

An unavoidable A/D conversion error that results simply from the conversion of a continuous voltage to its integer digital representation. Quantizing error is always  $\pm 0.5$  LSB and is the only error present in an ideal A/D converter.

**RALU**

Register arithmetic-logic unit. A part of the CPU that consists of the ALU, the PSW, the master PC, the microcode engine, a loop counter, and six registers.

**repeatability error**

The variation in *code transitions* when comparing a number of *actual characteristics* from the same converter on the same channel with the same temperature, voltage, and frequency conditions. The amount of repeatability error depends on the comparator's ability to resolve very similar voltages and the extent to which random noise contributes to the error.

**reserved memory**

A memory location that is reserved for factory use or for future expansion. Do not use a reserved memory location except to initialize it.

**resolution**

The number of input voltage levels that an A/D converter can unambiguously distinguish between. The number of useful bits of information that the converter can return.

**sample capacitor**

A small (2–3 pF) capacitor used in the A/D converter circuitry to store the input voltage on the selected input channel.

**sample delay**

The time period between the time that A/D converter receives the “start conversion” signal and the time that the *sample capacitor* is connected to the selected channel.

**sample delay uncertainty**

The variation in the *sample delay*.

**sample time**

The period of time that the *sample window* is open. (That is, the length of time that the input channel is actually connected to the *sample capacitor*.)

**sample time uncertainty**

The variation in the *sample time*.

**sample window**

The period of time that begins when the *sample capacitor* is attached to a selected channel of an *A/D converter* and ends when the sample capacitor is disconnected from the selected channel.

**sampled inputs**

All input pins, with the exception of RESET#, are sampled inputs. The input pin is sampled one state time before the read buffer is enabled. Sampling occurs during PH1 (while CLKOUT is low) and resolves the value (high or low) of the pin before it is presented to the internal bus. If the pin value changes during the sample time, the new value may or may not be recorded during the read.

RESET# is a level-sensitive input. EXTINT is normally a sampled input; however, the powerdown circuitry uses EXTINT as a level-sensitive input during powerdown mode.

**SAR**

*Successive approximation* register. A component of the *A/D converter*.

**set**

The “1” value of a bit or the act of giving it a “1” value. See also *clear*.

**SFR**

Special-function register.

**SHORT-INTEGER**

An 8-bit, signed variable with values from  $-2^7$  through  $+2^7-1$ .

**sign extension**

A method for converting data to a larger format by filling the upper bit positions with the value of the sign. This conversion preserves the positive or negative value of signed integers.

**sink current**

Current flowing **into** a device to ground. Always a positive value.

**source current**

Current flowing **out of** a device from  $V_{CC}$ . Always a negative value.

**SP**

Stack pointer.

**special interrupt**

Any of the three *nonmaskable interrupts* (unimplemented opcode, software trap, or NMI).

**special-purpose memory**

[www.DataSheet4U.com](http://www.DataSheet4U.com)

A partition of memory used for storing the *interrupt vectors*, *PTS vectors*, chip configuration bytes, and several reserved locations.

**standard interrupt**

Any *maskable interrupt* that is assigned to the *interrupt controller* for processing by an *interrupt service routine*.

**state time (or state)**

The basic time unit of the microcontroller; the combined period of the two internal timing signals, PH1 and PH2. Because the microcontroller can operate at many frequencies, this manual defines time requirements in terms of *state times* rather than in specific units of time.

**successive approximation**

An A/D conversion method that uses a binary search to arrive at the best digital representation of an analog input.

**t**

Lowercase “t” represents the period of the internal clock.

**temperature coefficient**

Change in the stated variable for each degree Centigrade of temperature change.

**temperature drift**

The change in a specification due to a change in temperature. Temperature drift can be calculated by using the *temperature coefficient* for the specification.

**terminal-based characteristic**

An *actual characteristic* that has been translated and scaled to remove *zero-offset error* and *full-scale error*. A terminal-based characteristic resembles an *actual characteristic* with zero-offset error and full-scale error removed.

**transfer function**

A graph of output *code* versus input voltage; the *characteristic* of the *A/D converter*.

**transfer function errors**

Errors inherent in an analog-to-digital conversion process: *quantizing error*, *zero-offset error*, *full-scale error*, *differential nonlinearity*, and *nonlinearity*. Errors that are hardware-dependent, rather than being inherent in the process itself, include *feedthrough*, *repeatability*, *channel-to-channel matching*, *off-isolation*, and  $V_{CC}$  *rejection errors*.

**UART**

Universal asynchronous receiver and transmitter. A part of the serial I/O port.

**V<sub>CC</sub> rejection**

[www.DataSheet4U.com](http://www.DataSheet4U.com)

The property of an A/D converter that causes it to ignore (reject) changes in V<sub>CC</sub> so that the *actual characteristic* is unaffected by those changes. The effectiveness of V<sub>CC</sub> rejection is measured by the ratio of the change in V<sub>CC</sub> to the change in the *actual characteristic*.

**VPW**

Variable pulse-width. A forced high/low symbol transition formatting scheme that tracks the duration between two consecutive transitions and the level of the bus, active or passive.

**wait state**

Time spent waiting for an operation to take place. Wait states are added to external bus cycles to allow a slow memory device to respond to a request from the microcontroller.

**watchdog timer**

An internal timer that resets the microcontroller if software fails to respond before the timer overflows.

**WDT**

*Watchdog timer.* An internal timer that resets the microcontroller if software fails to respond before the timer overflows.

**word**

Any 16-bit unit of data.

**WORD**

An unsigned, 16-bit variable with values from 0 through  $2^{16}-1$ .

**zero extension**

A method for converting data to a larger format by filling the upper bit positions with zeros.

**zero-offset error**

An ideal A/D converter's first *code transition* occurs when the input voltage is 0.5 LSB. Zero-offset error is the difference between 0.5 LSB and the actual input voltage that triggers an A/D converter's first code transition.



# Index



## A

- Address map, 3-1
- Address partitions
  - map, 3-1
  - OTPROM, 11-1
  - program memory, 11-1
  - special-purpose memory, 11-1
- ALE, idle, powerdown, reset status, A-8, A-9

## B

- Block diagram
  - 8XC196Lx, 2-2

## C

- CLKOUT
  - and internal timing, 2-2–2-4
  - idle, powerdown, reset status, A-8, A-9
  - output frequency, 2-5
  - reset status, 5-2
- Clock circuitry, 2-3, 10-2

## D

- delay register, 8-20
- Design considerations, 9-2
- Device pin reset status, A-8, A-9
- Documents, related, 1-2

## E

- EA#, idle, powerdown, reset status, A-8, A-9
- EPA
  - interrupt mask 1 register, 7-4
  - interrupt mask register, 7-4
  - interrupt pending 1 register, 7-5
  - interrupt pending register, 7-5
  - interrupt priority vector register, 7-6
- ESD protection, 5-2, 5-5

## F

- Formulas
  - clock period (t), 2-4
  - PH1 and PH2 frequency, 2-4
  - state time, 2-4

- Frequency (f), 2-4
- $F_{XTAL1}$ , 2-4

## H

- Hardware, pin reset status, A-8, A-9

## I

- Idle mode pin status, A-8, A-9
- Internal timing, 2-2, 10-1
- Interrupts
  - mask 1 register, 4-4
  - mask register, 4-3
  - pending 1 register, 4-6
  - pending register, 4-5
  - priorities, 4-2
  - sources, 4-2
  - vectors, 4-2

## J

- J1850 communications controller, 8-3–8-21
  - delay compensation, 8-20
  - in-frame response
    - command register, 8-17
  - interrupt status register, 8-21
  - oscillator prescaler
    - configuration register, 8-18
  - receiver register, 8-15
  - registers, 8-3–8-4
  - signals, 8-3
  - transmitter register, 8-14

## M

- Manual contents, summary, 1-1–1-2

## N

- Noise, reducing, 5-2

## O

- ONCE mode, entering and exiting, 10-2
- OTPROM address map, 11-1

## P

Period (t), 2-4

Port 0

idle, powerdown, reset status, A-8, A-9  
overview, 5-1

Port 1

configuring, 5-3  
idle, powerdown, reset status, A-8, A-9  
overview, 5-1

Port 2

configuring, 5-3  
idle, powerdown, reset status, A-8, A-9  
overview, 5-1  
P2.7 reset status, 5-2

Port 3

idle, powerdown, reset status, A-8, A-9  
internal structure, 5-5  
overview, 5-1

Port 4

idle, powerdown, reset status, A-8, A-9  
internal structure, 5-5  
overview, 5-1

Port 5

configuring, 5-3  
idle, powerdown, reset status, A-8, A-9  
overview, 5-1

Port 6

configuring, 5-3  
idle, powerdown, reset status, A-8, A-9  
overview, 5-1

Ports, input buffers, 5-2

Powerdown mode, pin status, A-8, A-9

PTS select register, 4-7

PTS service register, 4-8

## R

RD#, idle, powerdown, reset status, A-8, A-9

Register file

and windowing, 3-2  
description, 3-3

Registers

EPA\_MASK, 7-4  
EPA\_MASK1, 7-4  
EPA\_PEND, 7-5  
EPA\_PEND1, 7-5  
EPAIPV, 7-6  
INT\_MASK, 4-3

INT\_MASK1, 4-4

INT\_PEND, 4-5

INT\_PEND1, 4-6

J\_CFG, 8-18

J\_CMD, 8-17

J\_DLY, 8-20

J\_RX, 8-15

J\_STAT, 8-21

J\_TX, 8-14

PTSSEL, 4-7

PTSSRV, 4-8

RSTSRC, 9-1

SSIO0\_CLK, 6-1

SSIO1\_CLK, 6-2

USFR1, 2-6

Reset

pin status, A-8, A-9

status of CLKOUT/P2.7, 5-2

Reset source indicator register, 9-1

RESET#, idle, powerdown, reset status, A-8, A-9

## S

Serial port programming mode, 11-5

Signals

default conditions, A-8, A-9

status symbols defined, A-7

State time, defined, 2-4

Symbols, signal status, A-7

Synchronous serial port 0 clock register, 6-1

Synchronous serial port 1 clock register, 6-2

## U

Unerasable PROM 1 register, 2-6

## W

Windows

and address-mapped SFRs, 3-6

locations that cannot be windowed, 3-6

WSR values and direct addresses, 3-6

WR#, idle, powerdown, reset status, A-8, A-9