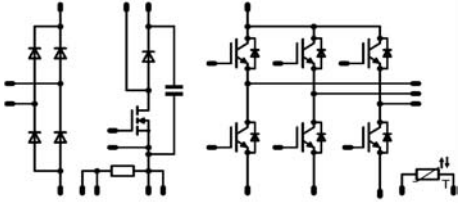

|   |  |
|---|--|
| <b>flowPIM0+PFC 2nd</b>   | <b>600V/15A</b>  |
| <div style="border: 1px solid black; padding: 5px; margin-bottom: 5px;"> <p style="text-align: center; background-color: #000080; color: white; margin: 0;"><b>Features</b></p> <ul style="list-style-type: none"> <li>Clip in PCB mounting</li> <li>Trench Fieldstop IGBT's for low saturation losses</li> <li>Latest generation superjunction MOSFET for PFC</li> </ul> </div> <div style="border: 1px solid black; padding: 5px; margin-bottom: 5px;"> <p style="text-align: center; background-color: #000080; color: white; margin: 0;"><b>Target Applications</b></p> <ul style="list-style-type: none"> <li>Industrial Drives</li> <li>Embedded Drives</li> </ul> </div> <div style="border: 1px solid black; padding: 5px;"> <p style="text-align: center; background-color: #000080; color: white; margin: 0;"><b>Types</b></p> <ul style="list-style-type: none"> <li>10-F006PPA015SB-M684B</li> </ul> </div> | <div style="border: 1px solid black; padding: 5px; margin-bottom: 5px;"> <p style="text-align: center; background-color: #000080; color: white; margin: 0;"><b>flowPIM0+PFC 2nd</b></p>  </div> <div style="border: 1px solid black; padding: 5px;"> <p style="text-align: center; background-color: #000080; color: white; margin: 0;"><b>Schematic</b></p>  </div> |

### Maximum Ratings

$T_j=25^{\circ}\text{C}$ , unless otherwise specified

| Parameter                       | Symbol     | Condition         | Value                     | Unit               |                      |
|---------------------------------|------------|-------------------|---------------------------|--------------------|----------------------|
| <b>Input Rectifier Diode</b>    |            |                   |                           |                    |                      |
| Repetitive peak reverse voltage | $V_{RRM}$  |                   | 1600                      | V                  |                      |
| DC forward current              | $I_{FAV}$  | $T_j=T_{jmax}$    | $T_h=80^{\circ}\text{C}$  | 26                 | A                    |
|                                 |            |                   | $T_c=80^{\circ}\text{C}$  | 36                 |                      |
| Surge forward current           | $I_{FSM}$  | $t_p=10\text{ms}$ | $T_j=150^{\circ}\text{C}$ | 200                | A                    |
| l2t-value                       | $I^2t$     |                   |                           | 200                | $\text{A}^2\text{s}$ |
| Power dissipation per Diode     | $P_{tot}$  | $T_j=T_{jmax}$    | $T_h=80^{\circ}\text{C}$  | 32                 | W                    |
|                                 |            |                   | $T_c=80^{\circ}\text{C}$  | 48                 |                      |
| Maximum Junction Temperature    | $T_{jmax}$ |                   | 150                       | $^{\circ}\text{C}$ |                      |

## Maximum Ratings

 $T_j=25^{\circ}\text{C}$ , unless otherwise specified

| Parameter                         | Symbol       | Condition  | Value    | Unit               |
|-----------------------------------|--------------|--|----------|--------------------|
| <b>PFC MOSFET</b>                 |              |  |          |                    |
| Drain to source breakdown voltage | $V_{DS}$     |  | 600      | V                  |
| DC drain current                  | $I_D$        | $T_j=T_{jmax}$<br>$T_h=80^{\circ}\text{C}$<br>$T_c=80^{\circ}\text{C}$     | 20<br>24 | A                  |
| Pulsed drain current              | $I_{Dpulse}$ | $T_j=25^{\circ}\text{C}$   | 159      | A                  |
| Avalanche energy, single pulse    | $E_{AS}$     | $I_D=9,3\text{A}$<br>$V_{DD}=50\text{V}$<br>$T_j=25^{\circ}\text{C}$       | 1135     | mJ                 |
| Avalanche energy, repetitive      | $E_{AR}$     | $I_D=9,3\text{A}$<br>$V_{DD}=50\text{V}$<br>$T_j=25^{\circ}\text{C}$       | 1,72     | mJ                 |
| Avalanche current, repetitive     | $I_{AR}$     |  | 9,3      | A                  |
| MOSFET dv/dt ruggedness           | dv/dt        | $V_{DS}=0\dots480\text{V}$   | 50       | V/ns               |
| Power dissipation                 | $P_{tot}$    | $T_j=T_{jmax}$<br>$T_h=80^{\circ}\text{C}$<br>$T_c=80^{\circ}\text{C}$     | 64<br>97 | W                  |
| Gate-source peak voltage          | $V_{GS}$     |  | $\pm 20$ | V                  |
| Reverse diode dv/dt               | dv/dt        | $V_{DS}=0\dots400\text{V}$ , $I_{SD} \leq I_D$<br>$T_j=25^{\circ}\text{C}$ | 15       | V/ns               |
| Maximum Junction Temperature      | $T_{jmax}$   |  | 150      | $^{\circ}\text{C}$ |

### PFC Diode

|                                   |            |  |          |                    |
|-----------------------------------|------------|--|----------|--------------------|
| Peak Repetitive Reverse Voltage   | $V_{RRM}$  | $T_j=25^{\circ}\text{C}$   | 600      | V                  |
| DC forward current                | $I_F$      | $T_j=T_{jmax}$<br>$T_h=80^{\circ}\text{C}$<br>$T_c=80^{\circ}\text{C}$ | 21<br>28 | A                  |
| Non-repetitive Peak Surge Current | $I_{FSM}$  | 60Hz Single Half-Sine Wave   | 300      | A                  |
| Power dissipation                 | $P_{tot}$  | $T_j=T_{jmax}$<br>$T_h=80^{\circ}\text{C}$<br>$T_c=80^{\circ}\text{C}$ | 34<br>52 | W                  |
| Maximum Junction Temperature      | $T_{jmax}$ |  | 150      | $^{\circ}\text{C}$ |

### PFC Shunt

|                             |           |                          |    |   |
|-----------------------------|-----------|--------------------------|----|---|
| DC forward current          | $I_F$     | $T_c=25^{\circ}\text{C}$ | 55 | A |
| Power dissipation per Shunt | $P_{tot}$ | $T_c=25^{\circ}\text{C}$ | 3  | W |

### Inverter Transistor

|                                      |                      |  |          |                    |
|--------------------------------------|----------------------|--|----------|--------------------|
| Collector-emitter break down voltage | $V_{CE}$             |  | 600      | V                  |
| DC collector current                 | $I_C$                | $T_j=T_{jmax}$<br>$T_h=80^{\circ}\text{C}$<br>$T_c=80^{\circ}\text{C}$ | 19<br>25 | A                  |
| Pulsed collector current             | $I_{Cpulse}$         | $t_p$ limited by $T_{jmax}$  | 45       | A                  |
| Turn off safe operating area         |                      | $V_{CE} \leq 600\text{V}$ , $T_j \leq T_{jmax}$                        | 45       | A                  |
| Power dissipation per IGBT           | $P_{tot}$            | $T_j=T_{jmax}$<br>$T_h=80^{\circ}\text{C}$<br>$T_c=80^{\circ}\text{C}$ | 45<br>69 | W                  |
| Gate-emitter peak voltage            | $V_{GE}$             |  | $\pm 20$ | V                  |
| Short circuit ratings                | $t_{SC}$<br>$V_{CC}$ | $T_j \leq 150^{\circ}\text{C}$<br>$V_{GE}=15\text{V}$                  | 6<br>360 | $\mu\text{s}$<br>V |
| Maximum Junction Temperature         | $T_{jmax}$           |  | 175      | $^{\circ}\text{C}$ |

## Maximum Ratings

 $T_j=25^{\circ}\text{C}$ , unless otherwise specified

| Parameter | Symbol | Condition | Value | Unit |
|-----------|--------|-----------|-------|------|
|-----------|--------|-----------|-------|------|

### Inverter Diode

|                                 |            |  |     |                    |
|---------------------------------|------------|--|-----|--------------------|
| Peak Repetitive Reverse Voltage | $V_{RRM}$  | $T_j=25^{\circ}\text{C}$                             | 600 | V                  |
| DC forward current              | $I_F$      | $T_j=T_{jmax}$                                       | 18  | A                  |
|                                 |            | $T_h=80^{\circ}\text{C}$<br>$T_c=80^{\circ}\text{C}$ | 25  |                    |
| Repetitive peak forward current | $I_{FRM}$  | $t_p$ limited by $T_{jmax}$                          | 30  | A                  |
| Power dissipation per Diode     | $P_{tot}$  | $T_j=T_{jmax}$                                       | 35  | W                  |
|                                 |            | $T_h=80^{\circ}\text{C}$<br>$T_c=80^{\circ}\text{C}$ | 52  |                    |
| Maximum Junction Temperature    | $T_{jmax}$ |  | 175 | $^{\circ}\text{C}$ |

### DC link Capacitor

|                |           |                          |     |   |
|----------------|-----------|--------------------------|-----|---|
| Max.DC voltage | $V_{MAX}$ | $T_c=25^{\circ}\text{C}$ | 500 | V |
|----------------|-----------|--------------------------|-----|---|

### Thermal Properties

|   |           |  |                            |                    |
|---|-----------|--|----------------------------|--------------------|
| Storage temperature                             | $T_{slg}$ |  | -40...+125                 | $^{\circ}\text{C}$ |
| Operation temperature under switching condition | $T_{op}$  |  | -40...+( $T_{jmax} - 25$ ) | $^{\circ}\text{C}$ |

### Insulation Properties

|                            |          |                   |          |    |
|----------------------------|----------|-------------------|----------|----|
| Insulation voltage         | $V_{is}$ | $t=2s$ DC voltage | 4000     | V  |
| Creepage distance          |          |                   | min 12,7 | mm |
| Clearance                  |          |                   | min 12,7 | mm |
| Comparative tracking index | CTI      |                   | >200     |    |

**Characteristic Values**

| Parameter                                     | Symbol     | Conditions   |  |                                  |                                       |     | Value        |      |  | Unit       |
|---|------------|--|--|----------------------------------|---------------------------------------|-----|--------------|------|--|------------|
|   |            | $V_{GE}[V]$ or $V_{GS}[V]$                                 | $V_r[V]$ or $V_{CE}[V]$ or $V_{DS}[V]$ | $I_c[A]$ or $I_F[A]$ or $I_D[A]$ | $T_j$                                 | Min | Typ          | Max  |  |            |
| <b>Input Rectifier Diode</b>                  |            |  |  |                                  |                                       |     |              |      |  |            |
| Forward voltage                               | $V_F$      |  |  | 25                               | $T_j=25^\circ C$<br>$T_j=125^\circ C$ |     | 1,20<br>1,17 |      |  | V          |
| Threshold voltage (for power loss calc. only) | $V_{td}$   |  |  | 25                               | $T_j=25^\circ C$<br>$T_j=125^\circ C$ |     | 0,92<br>0,81 |      |  | V          |
| Slope resistance (for power loss calc. only)  | $r_t$      |  |  | 25                               | $T_j=25^\circ C$<br>$T_j=125^\circ C$ |     | 11<br>14     |      |  | m $\Omega$ |
| Reverse current                               | $I_r$      |  | 1600                                   |                                  | $T_j=25^\circ C$<br>$T_j=125^\circ C$ |     |              | 0,05 |  | mA         |
| Thermal resistance chip to heatsink per chip  | $R_{thJH}$ | Thermal grease thickness $\leq$ 50um<br>$\lambda = 1$ W/mK |  |                                  |                                       |     | 2,20         |      |  | K/W        |

**PFC MOSFET**

|  |              |  |          |      |         |                                       |      |           |     |            |
|--|--------------|--|----------|------|---------|---------------------------------------|------|-----------|-----|------------|
| Static drain to source ON resistance         | $R_{DS(on)}$ |  | 10       |      | 15      | $T_j=25^\circ C$<br>$T_j=125^\circ C$ |      | 70<br>143 |     | m $\Omega$ |
| Gate threshold voltage                       | $V_{(GS)th}$ |  |          |      | 0,00172 | $T_j=25^\circ C$<br>$T_j=125^\circ C$ | 2,4  | 3         | 3,6 | V          |
| Gate to Source Leakage Current               | $I_{GSS}$    |  | 20       | 0    |         | $T_j=25^\circ C$<br>$T_j=125^\circ C$ |      |           | 100 | nA         |
| Zero Gate Voltage Drain Current              | $I_{DSS}$    |  | 0        | 600  |         | $T_j=25^\circ C$<br>$T_j=125^\circ C$ |      |           | 5   | nA         |
| Turn On Delay Time                           | $t_{d(ON)}$  | Rgoff=8 $\Omega$<br>Rgon=8 $\Omega$                        | $\pm 15$ | 400  | 15      | $T_j=25^\circ C$                      |      | 23        |     | ns         |
| Rise Time                                    | $t_r$        |  |          |      |         | $T_j=125^\circ C$                     |      | 21        |     |            |
| Turn off delay time                          | $t_{d(OFF)}$ |  |          |      |         | $T_j=25^\circ C$                      |      | 5         |     |            |
| Fall time                                    | $t_f$        |  |          |      |         | $T_j=125^\circ C$                     |      | 10        |     |            |
| Turn-on energy loss per pulse                | $E_{on}$     |  |          |      |         | $T_j=25^\circ C$                      |      | 164       |     |            |
| Turn-off energy loss per pulse               | $E_{off}$    |  |          |      |         | $T_j=125^\circ C$                     |      | 172       |     |            |
| Total gate charge                            | $Q_{GE}$     |  |          |      |         | $T_j=25^\circ C$                      |      | 7         |     |            |
| Gate to source charge                        | $Q_{GS}$     | $T_j=125^\circ C$  |          | 14   |         |                                       |      |           |     |            |
| Gate to drain charge                         | $Q_{GD}$     | $T_j=25^\circ C$   |          | 0,11 |         |                                       |      |           |     |            |
| Input capacitance                            | $C_{iss}$    | f=1MHz   | 0        | 100  |         | $T_j=25^\circ C$                      |      | 3800      |     | pF         |
| Output capacitance                           | $C_{oss}$    |  |          |      |         | $T_j=125^\circ C$                     |      | 215       |     |            |
| Gate resistance                              | $r_G$        |  |          |      |         |                                       |      | 0,85      |     |            |
| Thermal resistance chip to heatsink per chip | $R_{thJH}$   | Thermal grease thickness $\leq$ 50um<br>$\lambda = 1$ W/mK |          |      |         |                                       | 1,10 |           |     | K/W        |

**PFC Diode**

|  |                 |  |          |      |    |                                       |      |              |     |         |
|--|-----------------|--|----------|------|----|---------------------------------------|------|--------------|-----|---------|
| Forward voltage                              | $V_F$           |  |          |      | 30 | $T_j=25^\circ C$<br>$T_j=125^\circ C$ |      | 2,44<br>1,79 | 2,6 | V       |
| Reverse leakage current                      | $I_{rm}$        |  | $\pm 15$ | 400  | 15 | $T_j=25^\circ C$<br>$T_j=125^\circ C$ |      |              | 100 | $\mu A$ |
| Peak recovery current                        | $I_{RRM}$       | Rgon=8 $\Omega$  | $\pm 15$ | 400  | 15 | $T_j=25^\circ C$                      |      | 39           |     | A       |
| Reverse recovery time                        | $t_{rr}$        |  |          |      |    | $T_j=125^\circ C$                     |      | 20           |     |         |
| Reverse recovery charge                      | $Q_{rr}$        |  |          |      |    | $T_j=25^\circ C$                      |      | 13           |     |         |
| Reverse recovered energy                     | $E_{rec}$       |  |          |      |    | $T_j=125^\circ C$                     |      | 40           |     |         |
| Peak rate of fall of recovery current        | $di(rec)max/dt$ |  |          |      |    | $T_j=25^\circ C$                      |      | 0,25         |     |         |
|  |                 |  |          |      |    | $T_j=125^\circ C$                     |      | 0,48         |     |         |
|  |                 |  |          |      |    | $T_j=25^\circ C$                      |      | 0,04         |     |         |
|  |                 | $T_j=125^\circ C$  |          | 0,04 |    |                                       |      |              |     |         |
| Thermal resistance chip to heatsink per chip | $R_{thJH}$      | Thermal grease thickness $\leq$ 50um<br>$\lambda = 1$ W/mK |          |      |    |                                       | 2,05 |              |     | K/W     |

**PFC Shunt**

|                          |           |                                |  |  |  |  |  |    |    |            |
|--------------------------|-----------|--------------------------------|--|--|--|--|--|----|----|------------|
| R1 value                 | R         |                                |  |  |  |  |  | 10 |    | m $\Omega$ |
| Temperature coefficient  | $t_c$     | 20 $^\circ C$ to 60 $^\circ C$ |  |  |  |  |  |    | 30 | ppm/K      |
| Internal heat resistance | $R_{thi}$ |                                |  |  |  |  |  |    | 10 | K/W        |
| Inductance               | L         |                                |  |  |  |  |  |    | 3  | nH         |

**Characteristic Values**

| Parameter                                     | Symbol          | Conditions  |  |                                  |         |   | Value |              |      | Unit     |
|---|-----------------|---|--|----------------------------------|---------|---|-------|--------------|------|----------|
|   |                 | $V_{GE}[V]$ or $V_{GS}[V]$                                    | $V_r[V]$ or $V_{CE}[V]$ or $V_{DS}[V]$ | $I_c[A]$ or $I_F[A]$ or $I_D[A]$ | $T_j$   | Min                                     | Typ   | Max          |      |          |
| <b>Inverter Transistor</b>                    |                 |   |  |                                  |         |   |       |              |      |          |
| Gate emitter threshold voltage                | $V_{GE(th)}$    | $V_{CE}=V_{GE}$   |  |                                  | 0,00021 | $T_j=25^{\circ}C$<br>$T_j=125^{\circ}C$ | 5     | 5,8          | 6,5  | V        |
| Collector-emitter saturation voltage          | $V_{CE(sat)}$   |   | 15                                     |                                  | 15      | $T_j=25^{\circ}C$<br>$T_j=125^{\circ}C$ | 1,1   | 1,61<br>1,81 | 1,9  | V        |
| Collector-emitter cut-off current incl. Diode | $I_{CES}$       |   | 0                                      | 600                              |         | $T_j=25^{\circ}C$<br>$T_j=125^{\circ}C$ |       |              | 0,85 | $\mu A$  |
| Gate-emitter leakage current                  | $I_{GES}$       |   | 20                                     | 0                                |         | $T_j=25^{\circ}C$<br>$T_j=125^{\circ}C$ |       |              | 300  | nA       |
| Integrated Gate resistor                      | $R_{gint}$      |   |  |                                  |         |   |       | none         |      | $\Omega$ |
| Turn-on delay time                            | $t_{d(on)}$     | $R_{goff}=16 \Omega$<br>$R_{gon}=16 \Omega$                   | $\pm 15$                               | 400                              | 15      | $T_j=25^{\circ}C$                       |       | 49           |      | ns       |
| Rise time                                     | $t_r$           |   |  |                                  |         | $T_j=125^{\circ}C$                      |       | 50           |      |          |
| Turn-off delay time                           | $t_{d(off)}$    |   |  |                                  |         | $T_j=25^{\circ}C$                       |       | 20           |      |          |
| Fall time                                     | $t_f$           |   |  |                                  |         | $T_j=125^{\circ}C$                      |       | 21           |      |          |
| Turn-on energy loss per pulse                 | $E_{on}$        |   |  |                                  |         | $T_j=25^{\circ}C$                       |       | 120          |      |          |
| Turn-off energy loss per pulse                | $E_{off}$       | $T_j=125^{\circ}C$  |  | 142                              |         |   |       |              |      |          |
| Input capacitance                             | $C_{ies}$       |   |  |                                  |         | $T_j=25^{\circ}C$                       |       | 860          |      | pF       |
| Output capacitance                            | $C_{oss}$       | $f=1MHz$  | 0                                      | 25                               |         | $T_j=25^{\circ}C$                       |       | 55           |      |          |
| Reverse transfer capacitance                  | $C_{rss}$       |   |  |                                  |         | $T_j=25^{\circ}C$                       |       | 24           |      |          |
| Gate charge                                   | $Q_{Gate}$      |   | $\pm 15$                               | 480                              | 15      | $T_j=25^{\circ}C$                       |       | 87           |      | nC       |
| Thermal resistance chip to heatsink per chip  | $R_{thJH}$      | Thermal grease thickness $\leq 50\mu m$<br>$\lambda = 1 W/mK$ |  |                                  |         |   |       | 2,10         |      | K/W      |
| <b>Inverter Diode</b>                         |                 |   |  |                                  |         |   |       |              |      |          |
| Diode forward voltage                         | $V_F$           |   |  |                                  | 15      | $T_j=25^{\circ}C$<br>$T_j=125^{\circ}C$ | 1,28  | 1,79<br>1,67 | 1,95 | V        |
| Peak reverse recovery current                 | $I_{RRM}$       | $R_{gon}=16 \Omega$   | $\pm 15$                               | 400                              | 15      | $T_j=25^{\circ}C$                       |       | 9            |      | A        |
| Reverse recovery time                         | $t_{rr}$        |   |  |                                  |         | $T_j=125^{\circ}C$                      |       | 11           |      |          |
| Reverse recovered charge                      | $Q_{rr}$        |   |  |                                  |         | $T_j=25^{\circ}C$                       |       | 178          |      |          |
| Peak rate of fall of recovery current         | $di(rec)max/dt$ |   |  |                                  |         | $T_j=125^{\circ}C$                      |       | 255          |      |          |
| Reverse recovered energy                      | $E_{rec}$       |   |  |                                  |         | $T_j=25^{\circ}C$                       |       | 0,71         |      |          |
|   |                 | $T_j=125^{\circ}C$  |  | 1,40                             |         |   |       |              |      |          |
|   |                 | $T_j=25^{\circ}C$   |  | 37                               |         |   |       |              |      |          |
|   |                 | $T_j=125^{\circ}C$  |  | 74                               |         |   |       |              |      |          |
|   |                 | $T_j=25^{\circ}C$   |  | 0,20                             |         |   |       |              |      |          |
|   |                 | $T_j=125^{\circ}C$  |  | 0,40                             |         |   |       |              |      |          |
| Thermal resistance chip to heatsink per chip  | $R_{thJH}$      | Thermal grease thickness $\leq 50\mu m$<br>$\lambda = 1 W/mK$ |  |                                  |         |   |       | 2,75         |      | K/W      |
| <b>DC link Capacitor</b>                      |                 |   |  |                                  |         |   |       |              |      |          |
| C value                                       | C               |   |  |                                  |         |   |       | 100          |      | nF       |
| <b>Thermistor</b>                             |                 |   |  |                                  |         |   |       |              |      |          |
| Rated resistance                              | R               |   |  |                                  |         | $T_j=25^{\circ}C$                       |       | 22000        |      | $\Omega$ |
| Deviation of R100                             | $\Delta R/R$    | $R_{100}=1486 \Omega$   |  |                                  |         | $T_c=100^{\circ}C$                      | -5    |              | 5    | %        |
| Power dissipation                             | P               |   |  |                                  |         | $T_j=25^{\circ}C$                       |       | 210          |      | mW       |
| Power dissipation constant                    |                 |   |  |                                  |         | $T_j=25^{\circ}C$                       |       | 3,5          |      | mW/K     |
| B-value                                       | $B_{(25/50)}$   | Tol. $\pm 3\%$  |  |                                  |         | $T_j=25^{\circ}C$                       |       |              |      | K        |
| B-value                                       | $B_{(25/100)}$  | Tol. $\pm 3\%$  |  |                                  |         | $T_j=25^{\circ}C$                       |       | 4000         |      | K        |
| Vincotech NTC Reference                       |                 |   |  |                                  |         | $T_j=25^{\circ}C$                       |       |              | A    |          |

## Output Inverter

**Figure 1** Output inverter IGBT

**Typical output characteristics**

$$I_C = f(V_{CE})$$

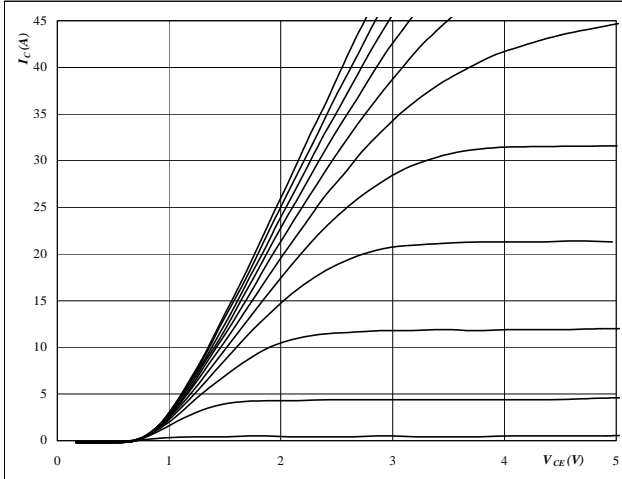

**At**  
 $t_p = 250 \mu s$   
 $T_j = 25 \text{ } ^\circ C$   
 $V_{GE}$  from 7 V to 17 V in steps of 1 V

**Figure 2** Output inverter IGBT

**Typical output characteristics**

$$I_C = f(V_{CE})$$

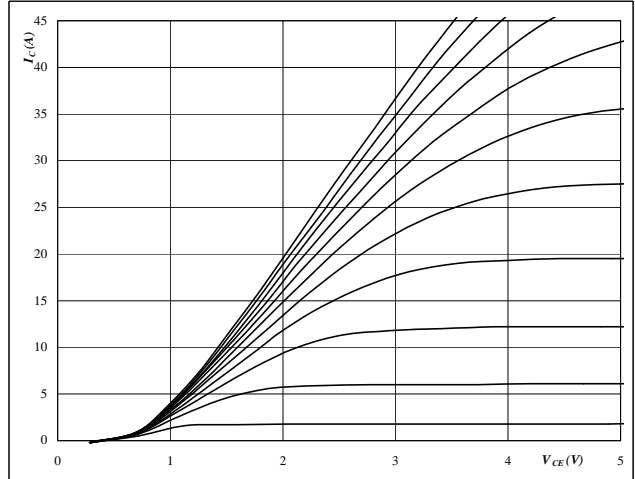

**At**  
 $t_p = 250 \mu s$   
 $T_j = 125 \text{ } ^\circ C$   
 $V_{GE}$  from 7 V to 17 V in steps of 1 V

**Figure 3** Output inverter IGBT

**Typical transfer characteristics**

$$I_C = f(V_{GE})$$

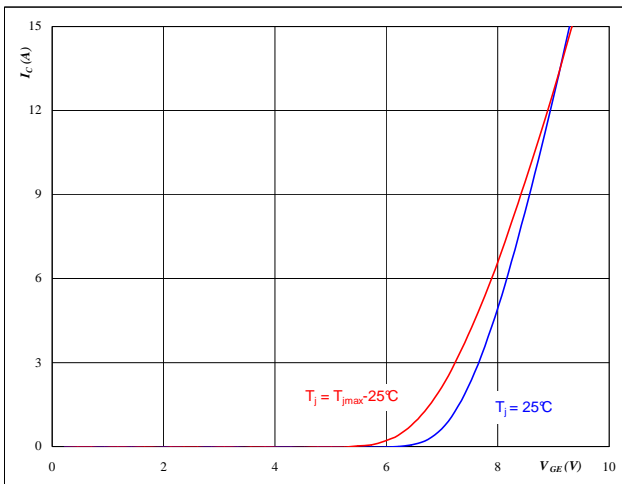

**At**  
 $t_p = 250 \mu s$   
 $V_{CE} = 10 \text{ V}$

**Figure 4** Output inverter FWD

**Typical diode forward current as a function of forward voltage**

$$I_F = f(V_F)$$

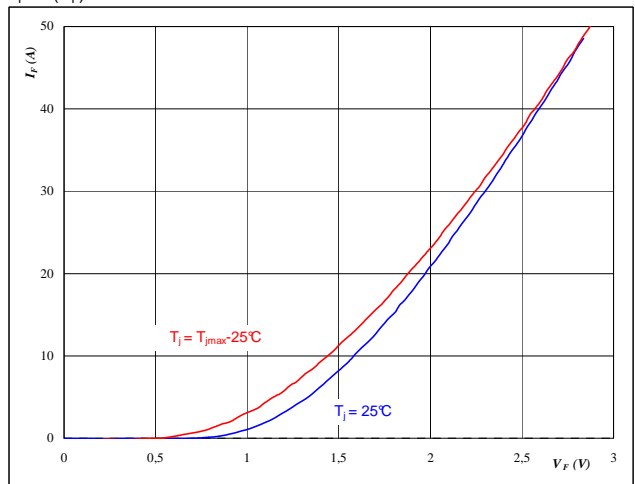

**At**  
 $t_p = 250 \mu s$

## Output Inverter

**Figure 5** Output inverter IGBT

**Typical switching energy losses as a function of collector current**

$$E = f(I_C)$$

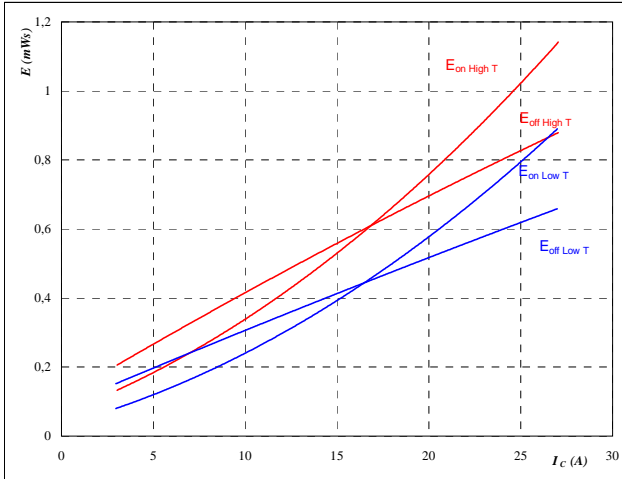

With an inductive load at

|              |        |    |
|--------------|--------|----|
| $T_J =$      | 25/125 | °C |
| $V_{CE} =$   | 400    | V  |
| $V_{GE} =$   | ±15    | V  |
| $R_{gon} =$  | 16     | Ω  |
| $R_{goff} =$ | 16     | Ω  |

**Figure 6** Output inverter IGBT

**Typical switching energy losses as a function of gate resistor**

$$E = f(R_G)$$

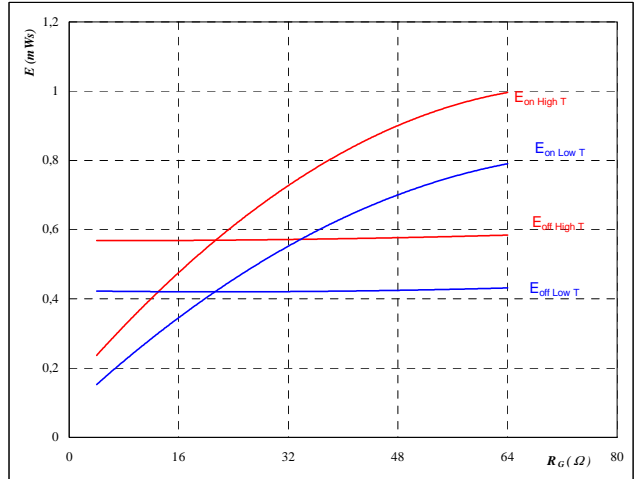

With an inductive load at

|            |        |    |
|------------|--------|----|
| $T_J =$    | 25/125 | °C |
| $V_{CE} =$ | 400    | V  |
| $V_{GE} =$ | ±15    | V  |
| $I_C =$    | 15     | A  |

**Figure 7** Output inverter FWD

**Typical reverse recovery energy loss as a function of collector current**

$$E_{rec} = f(I_C)$$

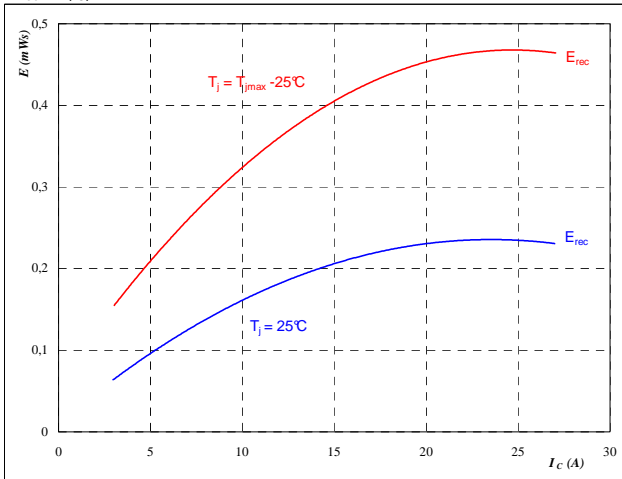

With an inductive load at

|             |        |    |
|-------------|--------|----|
| $T_J =$     | 25/125 | °C |
| $V_{CE} =$  | 400    | V  |
| $V_{GE} =$  | ±15    | V  |
| $R_{gon} =$ | 16     | Ω  |

**Figure 8** Output inverter FWD

**Typical reverse recovery energy loss as a function of gate resistor**

$$E_{rec} = f(R_G)$$

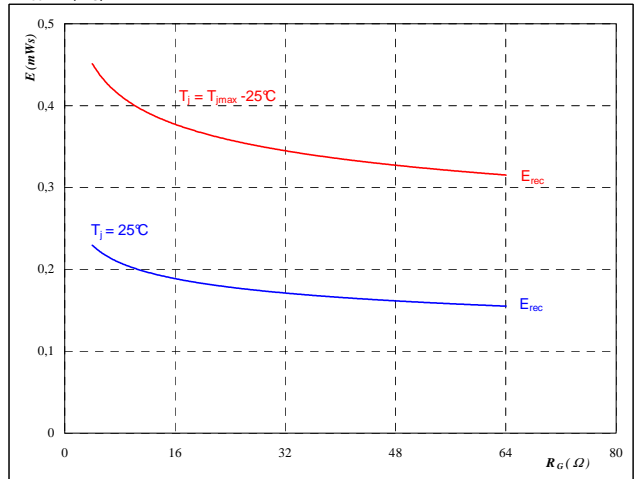

With an inductive load at

|            |        |    |
|------------|--------|----|
| $T_J =$    | 25/125 | °C |
| $V_{CE} =$ | 400    | V  |
| $V_{GE} =$ | ±15    | V  |
| $I_C =$    | 15     | A  |

## Output Inverter

**Figure 9** Output inverter IGBT

**Typical switching times as a function of collector current**

$$t = f(I_C)$$

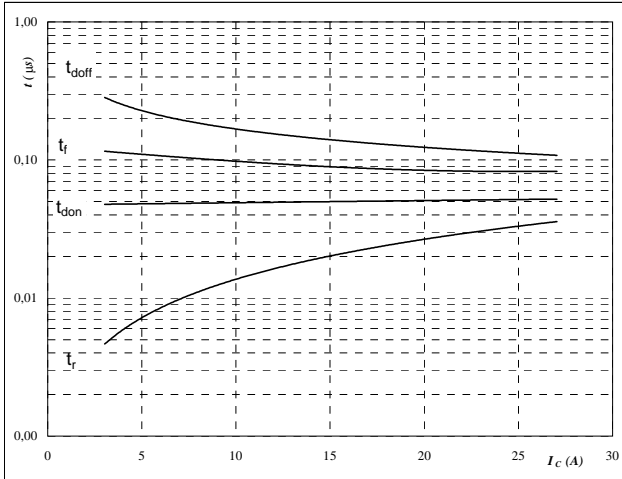

With an inductive load at

|                     |          |                    |
|---------------------|----------|--------------------|
| $T_j =$             | 125      | $^{\circ}\text{C}$ |
| $V_{\text{CE}} =$   | 400      | V                  |
| $V_{\text{GE}} =$   | $\pm 15$ | V                  |
| $R_{\text{gon}} =$  | 16       | $\Omega$           |
| $R_{\text{goff}} =$ | 16       | $\Omega$           |

**Figure 10** Output inverter IGBT

**Typical switching times as a function of gate resistor**

$$t = f(R_G)$$

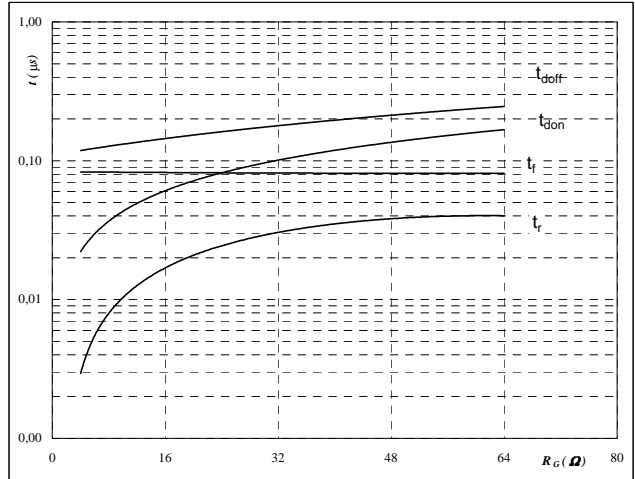

With an inductive load at

|                   |          |                    |
|-------------------|----------|--------------------|
| $T_j =$           | 125      | $^{\circ}\text{C}$ |
| $V_{\text{CE}} =$ | 400      | V                  |
| $V_{\text{GE}} =$ | $\pm 15$ | V                  |
| $I_C =$           | 15       | A                  |

**Figure 11** Output inverter FWD

**Typical reverse recovery time as a function of collector current**

$$t_{\text{rr}} = f(I_C)$$

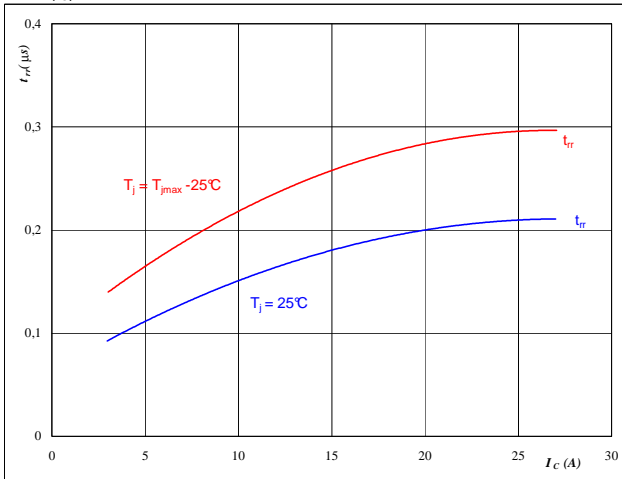

**At**

|                    |          |                    |
|--------------------|----------|--------------------|
| $T_j =$            | 25/125   | $^{\circ}\text{C}$ |
| $V_{\text{CE}} =$  | 400      | V                  |
| $V_{\text{GE}} =$  | $\pm 15$ | V                  |
| $R_{\text{gon}} =$ | 16       | $\Omega$           |

**Figure 12** Output inverter FWD

**Typical reverse recovery time as a function of IGBT turn on gate resistor**

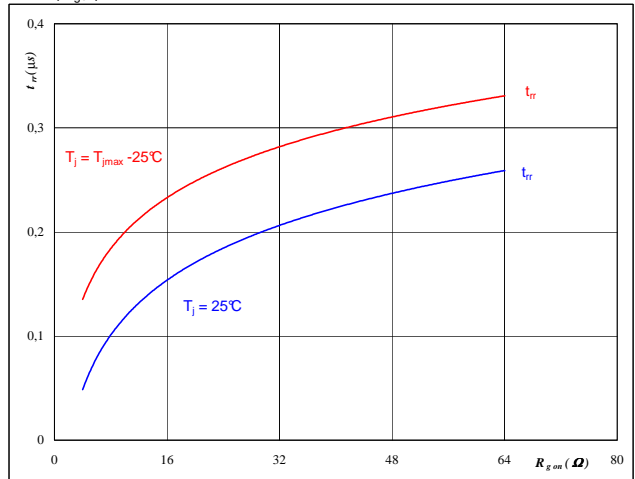
$$t_{\text{rr}} = f(R_{\text{gon}})$$

**At**

|                   |          |                    |
|-------------------|----------|--------------------|
| $T_j =$           | 25/125   | $^{\circ}\text{C}$ |
| $V_R =$           | 400      | V                  |
| $I_F =$           | 15       | A                  |
| $V_{\text{GE}} =$ | $\pm 15$ | V                  |



## Output Inverter

**Figure 13** Output inverter FWD

Typical reverse recovery charge as a function of collector current

$$Q_{rr} = f(I_C)$$

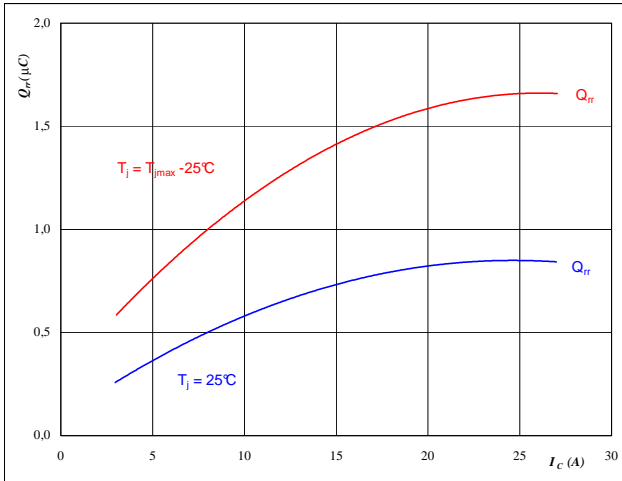

At

|             |        |    |
|-------------|--------|----|
| $T_j =$     | 25/125 | °C |
| $V_{CE} =$  | 400    | V  |
| $V_{GE} =$  | ±15    | V  |
| $R_{gon} =$ | 16     | Ω  |

**Figure 14** Output inverter FWD

Typical reverse recovery charge as a function of IGBT turn on gate resistor

$$Q_{rr} = f(R_{gon})$$

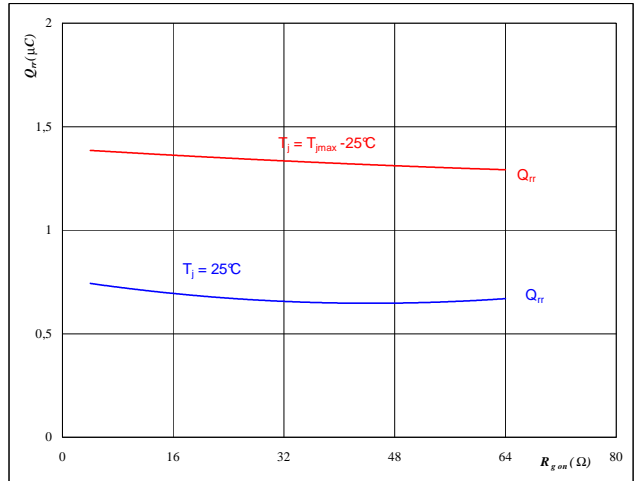

At

|            |        |    |
|------------|--------|----|
| $T_j =$    | 25/125 | °C |
| $V_R =$    | 400    | V  |
| $I_F =$    | 15     | A  |
| $V_{GE} =$ | ±15    | V  |

**Figure 15** Output inverter FWD

Typical reverse recovery current as a function of collector current

$$I_{RRM} = f(I_C)$$

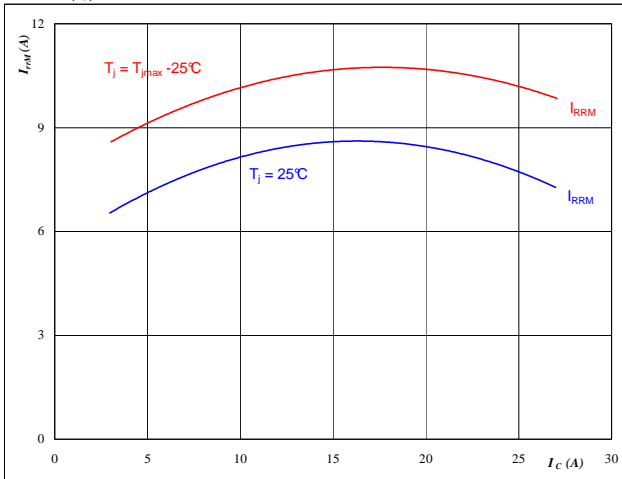

At

|             |        |    |
|-------------|--------|----|
| $T_j =$     | 25/125 | °C |
| $V_{CE} =$  | 400    | V  |
| $V_{GE} =$  | ±15    | V  |
| $R_{gon} =$ | 16     | Ω  |

**Figure 16** Output inverter FWD

Typical reverse recovery current as a function of IGBT turn on gate resistor

$$I_{RRM} = f(R_{gon})$$

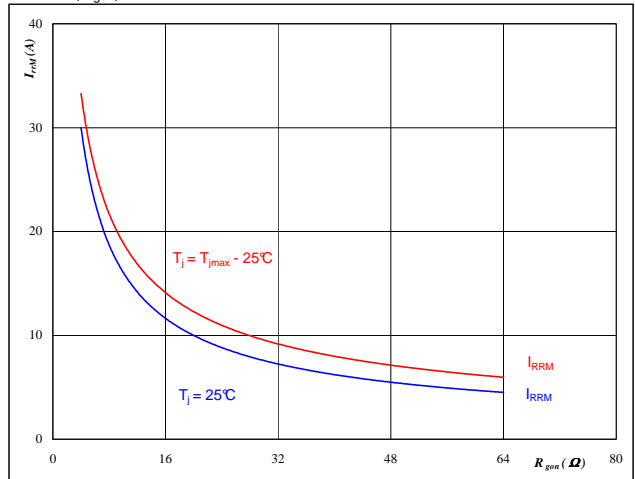

At

|            |        |    |
|------------|--------|----|
| $T_j =$    | 25/125 | °C |
| $V_R =$    | 400    | V  |
| $I_F =$    | 15     | A  |
| $V_{GE} =$ | ±15    | V  |

## Output Inverter

Figure 17 Output inverter FWD

Typical rate of fall of forward and reverse recovery current as a function of collector current

$$dI_f/dt, dI_{rec}/dt = f(I_C)$$

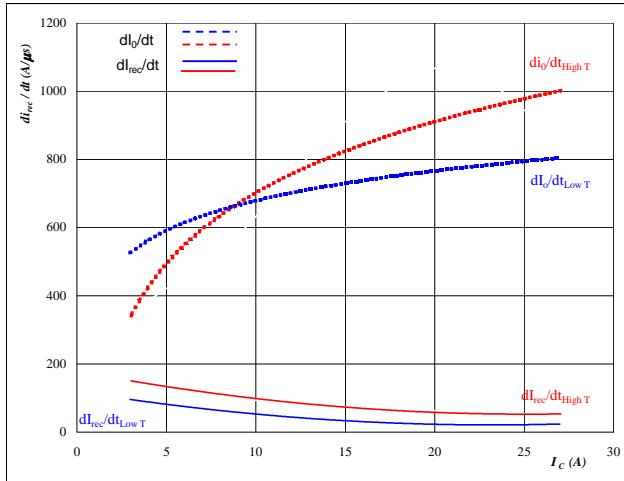

At  
 $T_j = 25/125 \text{ } ^\circ\text{C}$   
 $V_{CE} = 400 \text{ V}$   
 $V_{GE} = \pm 15 \text{ V}$   
 $R_{gon} = 16 \text{ } \Omega$

Figure 18 Output inverter FWD

Typical rate of fall of forward and reverse recovery current as a function of IGBT turn on gate resistor

$$dI_f/dt, dI_{rec}/dt = f(R_{gon})$$

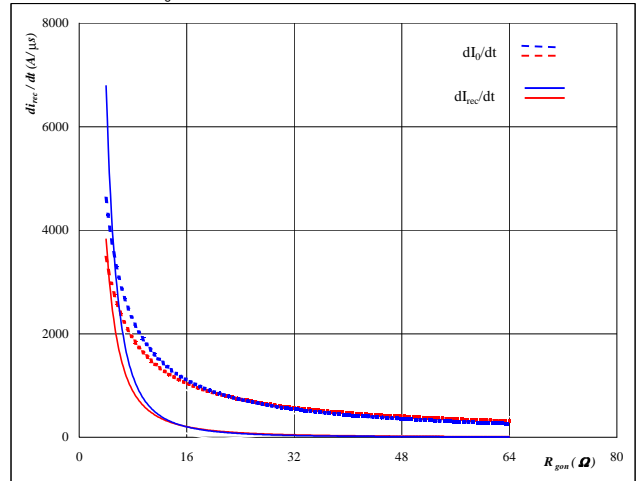

At  
 $T_j = 25/125 \text{ } ^\circ\text{C}$   
 $V_R = 400 \text{ V}$   
 $I_F = 15 \text{ A}$   
 $V_{GE} = \pm 15 \text{ V}$

Figure 19 Output inverter IGBT

IGBT transient thermal impedance as a function of pulse width

$$Z_{thJH} = f(t_p)$$

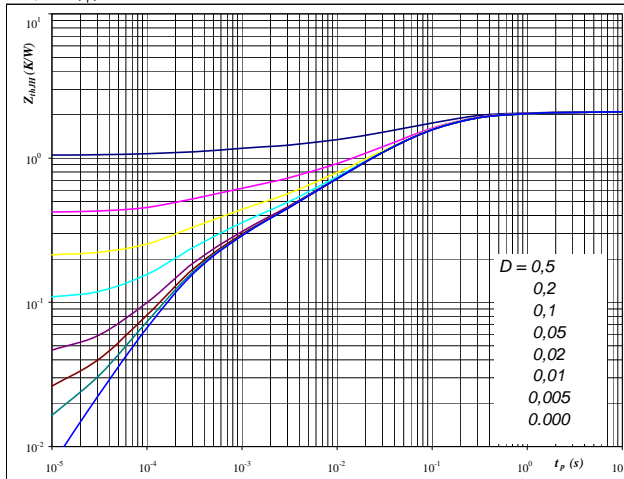

At  
 $D = t_p / T$   
 $R_{thJH} = 2,10 \text{ K/W}$       $R_{thJH} = 1,70 \text{ K/W}$

### IGBT thermal model values

| Thermal grease |         | Phase change interface |         |
|----------------|---------|------------------------|---------|
| R (C/W)        | Tau (s) | R (C/W)                | Tau (s) |
| 0,07           | 3,4E+00 | 0,06                   | 2,8E+00 |
| 0,25           | 3,7E-01 | 0,20                   | 3,0E-01 |
| 0,98           | 7,6E-02 | 0,79                   | 6,2E-02 |
| 0,42           | 1,4E-02 | 0,34                   | 1,1E-02 |
| 0,19           | 2,5E-03 | 0,16                   | 2,1E-03 |
| 0,19           | 3,0E-04 | 0,15                   | 2,4E-04 |

Figure 20 Output inverter FWD

FWD transient thermal impedance as a function of pulse width

$$Z_{thJH} = f(t_p)$$

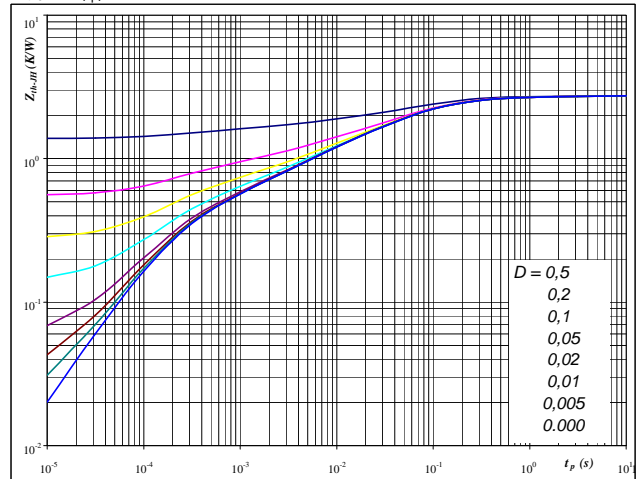

At  
 $D = t_p / T$   
 $R_{thJH} = 2,75 \text{ K/W}$       $R_{thJH} = 2,23 \text{ K/W}$

### FWD thermal model values

| Thermal grease |         | Phase change interface |         |
|----------------|---------|------------------------|---------|
| R (C/W)        | Tau (s) | R (C/W)                | Tau (s) |
| 0,05           | 8,2E+00 | 0,04                   | 6,6E+00 |
| 0,17           | 7,4E-01 | 0,14                   | 6,0E-01 |
| 0,78           | 1,1E-01 | 0,64                   | 8,7E-02 |
| 0,74           | 3,1E-02 | 0,60                   | 2,5E-02 |
| 0,48           | 5,4E-03 | 0,39                   | 4,4E-03 |
| 0,24           | 8,5E-04 | 0,19                   | 6,9E-04 |

## Output Inverter

**Figure 21** Output inverter IGBT

**Power dissipation as a function of heatsink temperature**

$$P_{tot} = f(T_h)$$

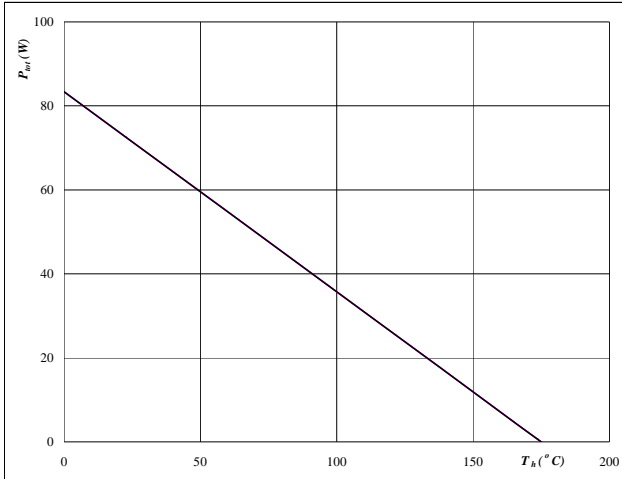
**At**  
 $T_j = 175 \text{ } ^\circ\text{C}$ 
**Figure 22** Output inverter IGBT

**Collector current as a function of heatsink temperature**

$$I_C = f(T_h)$$

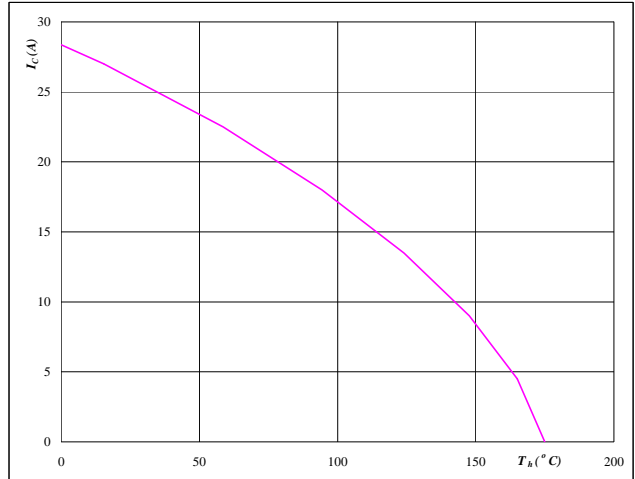
**At**  
 $T_j = 175 \text{ } ^\circ\text{C}$   
 $V_{GE} = 15 \text{ V}$ 
**Figure 23** Output inverter FWD

**Power dissipation as a function of heatsink temperature**

$$P_{tot} = f(T_h)$$

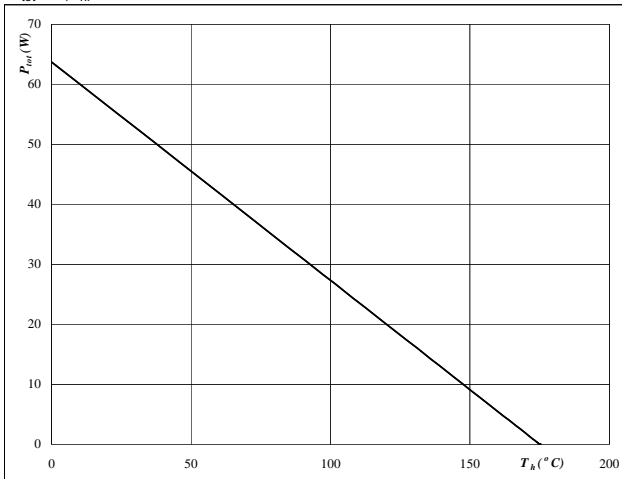
**At**  
 $T_j = 175 \text{ } ^\circ\text{C}$ 
**Figure 24** Output inverter FWD

**Forward current as a function of heatsink temperature**

$$I_F = f(T_h)$$

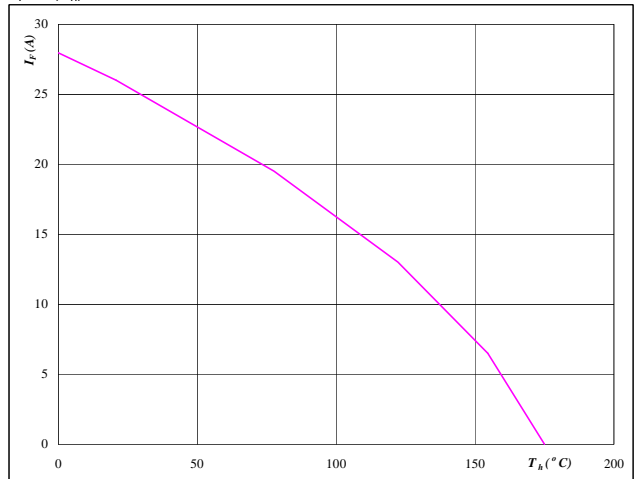
**At**  
 $T_j = 175 \text{ } ^\circ\text{C}$

## Output Inverter

**Figure 25** Output inverter IGBT

Safe operating area as a function of collector-emitter voltage  
 $I_C = f(V_{CE})$

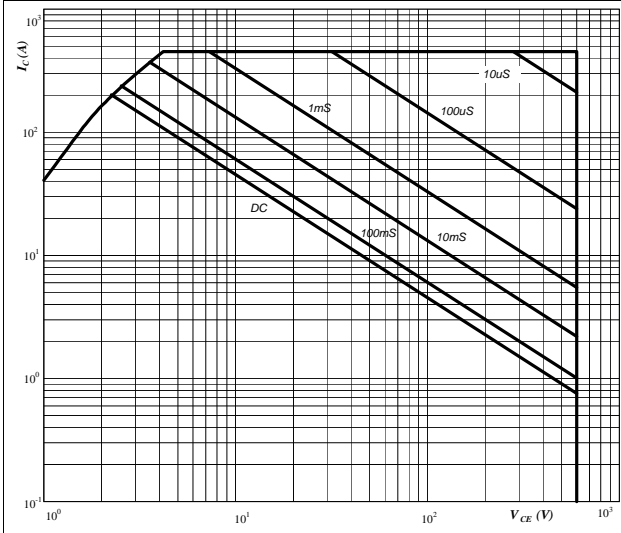

**At**  
 D = single pulse  
 $T_h = 80$  °C  
 $V_{GE} = \pm 15$  V  
 $T_j = T_{jmax}$  °C

**Figure 26** Output inverter IGBT

Gate voltage vs Gate charge

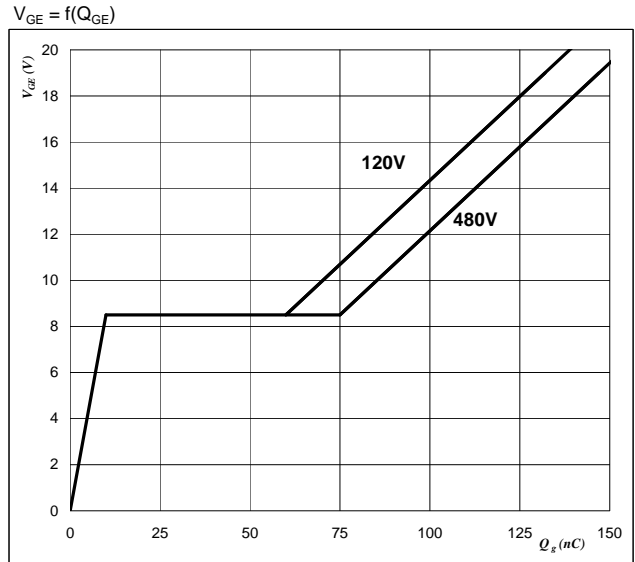

**At**  
 $I_C = 15$  A

**Figure 27** Output inverter IGBT

Short circuit withstand time as a function of gate-emitter voltage  
 $t_{sc} = f(V_{GE})$

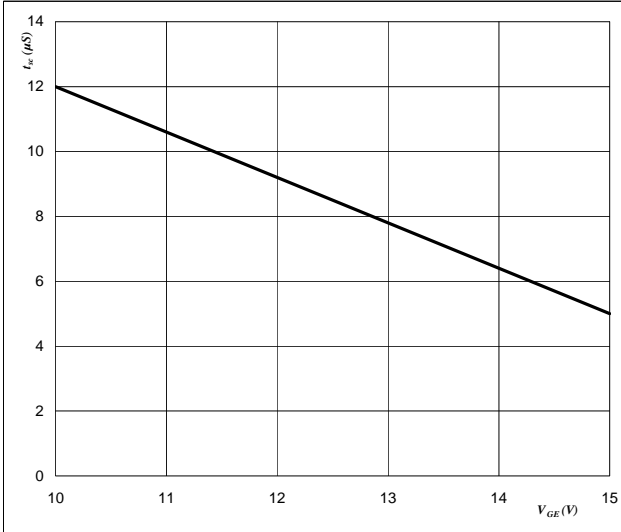

**At**  
 $V_{CE} = 600$  V  
 $T_j \leq 175$  °C

**Figure 28** Output inverter IGBT

Typical short circuit collector current as a function of gate-emitter voltage  
 $V_{GE} = f(Q_{GE})$

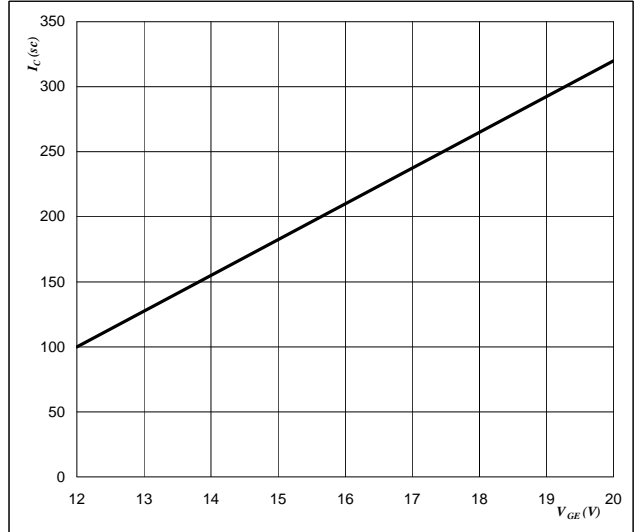

**At**  
 $V_{CE} \leq 600$  V  
 $T_j = 175$  °C

**Figure 29** IGBT

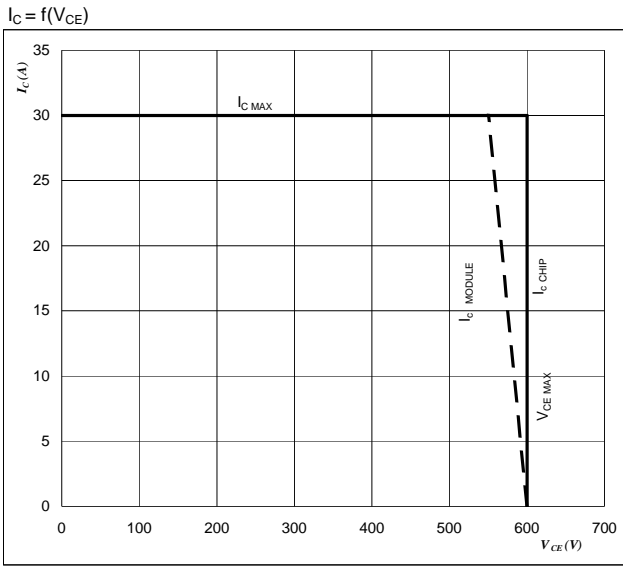
**Reverse bias safe operating area**

**At**

$$T_J = T_{jmax} - 25 \quad ^\circ\text{C}$$

$$U_{ocmin} = U_{ccplus}$$

Switching mode : 3 level switching

**PFC**
**Figure 1** PFC MOSFET

**Typical output characteristics**

$I_D = f(V_{DS})$

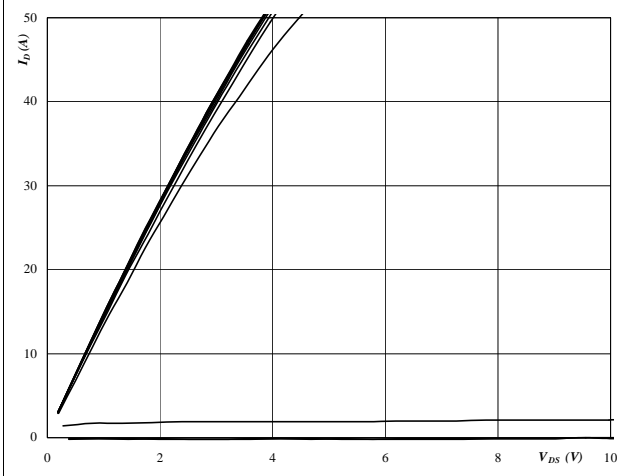

**At**  
 $t_p = 250 \mu s$   
 $T_j = 25 \text{ }^\circ C$   
 $V_{GS}$  from 0 V to 20 V in steps of 2 V

**Figure 2** PFC MOSFET

**Typical output characteristics**

$I_D = f(V_{DS})$

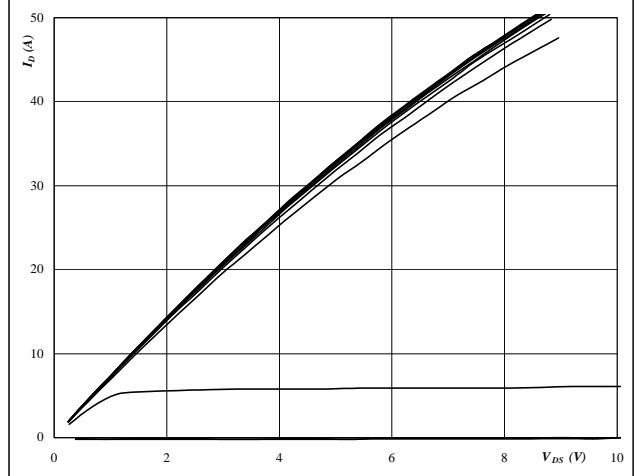

**At**  
 $t_p = 250 \mu s$   
 $T_j = 125 \text{ }^\circ C$   
 $V_{GS}$  from 0 V to 20 V in steps of 2 V

**Figure 3** PFC MOSFET

**Typical transfer characteristics**

$I_D = f(V_{GS})$

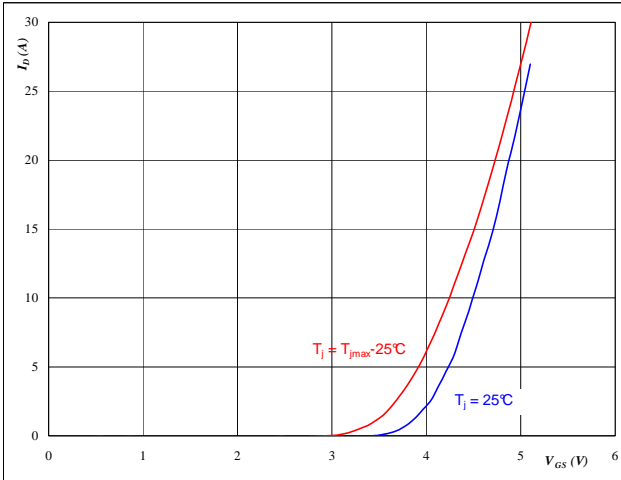

**At**  
 $t_p = 250 \mu s$   
 $V_{DS} = 10 V$

**Figure 4** PFC FWD

**Typical diode forward current as a function of forward voltage**

$I_F = f(V_F)$

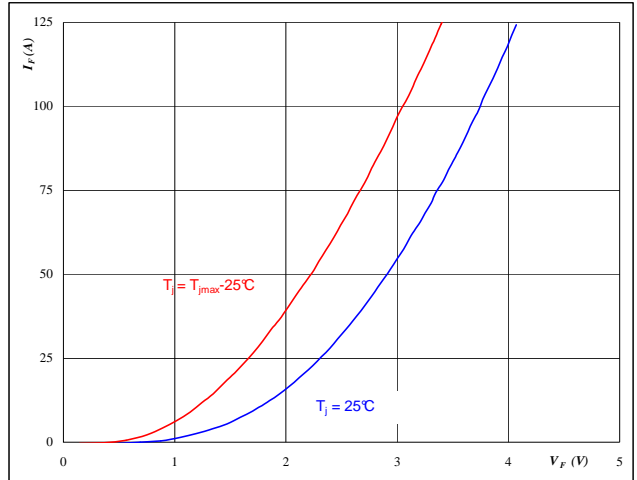

**At**  
 $t_p = 250 \mu s$

**PFC**
**Figure 5** PFC MOSFET

**Typical switching energy losses as a function of collector current**

$E = f(I_D)$

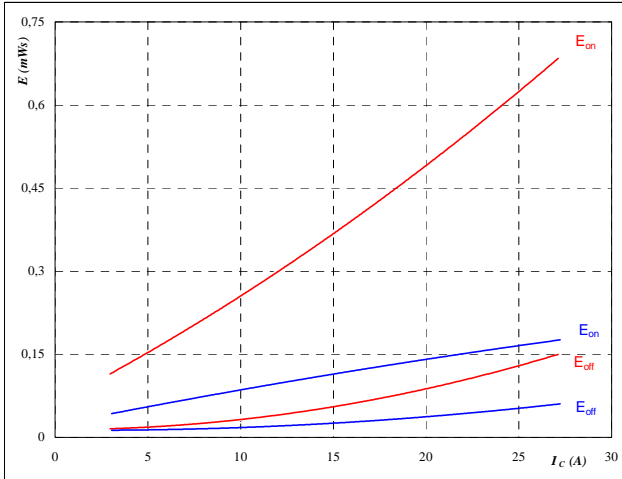

With an inductive load at

|              |        |    |
|--------------|--------|----|
| $T_j =$      | 25/125 | °C |
| $V_{DS} =$   | 400    | V  |
| $V_{GS} =$   | 10     | V  |
| $R_{gon} =$  | 8      | Ω  |
| $R_{goff} =$ | 8      | Ω  |

**Figure 6** PFC MOSFET

**Typical switching energy losses as a function of gate resistor**

$E = f(R_G)$

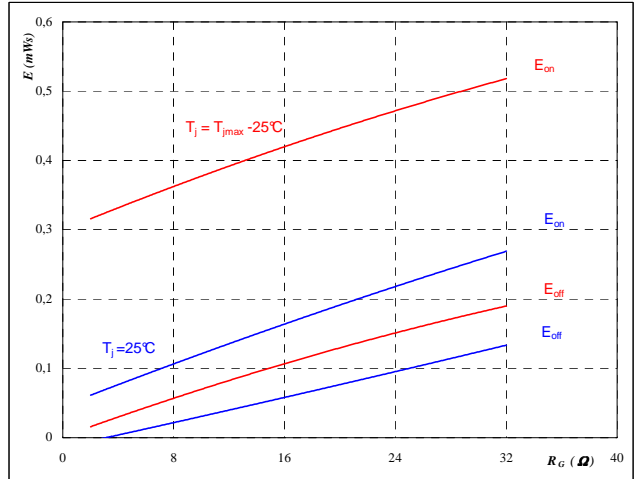

With an inductive load at

|            |        |    |
|------------|--------|----|
| $T_j =$    | 25/125 | °C |
| $V_{DS} =$ | 400    | V  |
| $V_{GS} =$ | 10     | V  |
| $I_D =$    | 15     | A  |

**Figure 7** PFC MOSFET

**Typical reverse recovery energy loss as a function of collector (drain) current**

$E_{rec} = f(I_C)$

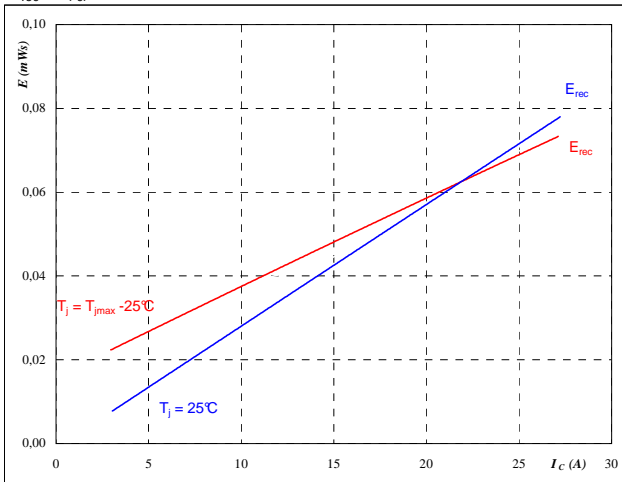

With an inductive load at

|              |        |    |
|--------------|--------|----|
| $T_j =$      | 25/125 | °C |
| $V_{DS} =$   | 400    | V  |
| $V_{GS} =$   | 10     | V  |
| $R_{gon} =$  | 8      | Ω  |
| $R_{goff} =$ | 8      | Ω  |

**Figure 8** PFC MOSFET

**Typical reverse recovery energy loss as a function of gate resistor**

$E_{rec} = f(R_G)$

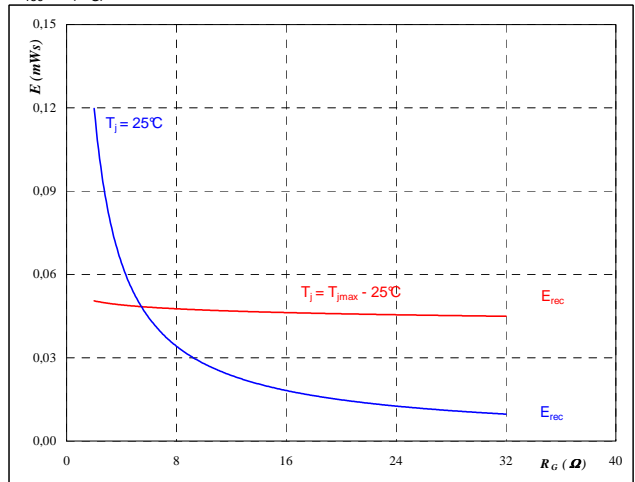

With an inductive load at

|            |        |    |
|------------|--------|----|
| $T_j =$    | 25/125 | °C |
| $V_{DS} =$ | 400    | V  |
| $V_{GS} =$ | 10     | V  |
| $I_D =$    | 15     | A  |

**PFC**
**Figure 9** PFC MOSFET

**Typical switching times as a function of collector current**

$t = f(I_D)$

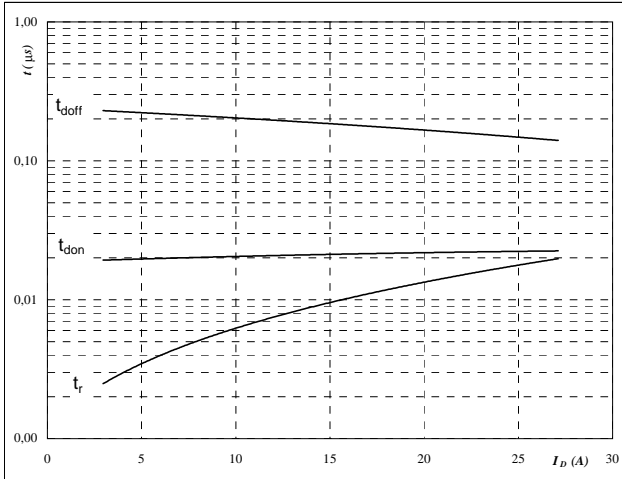

With an inductive load at

|              |     |    |
|--------------|-----|----|
| $T_J =$      | 125 | °C |
| $V_{DS} =$   | 400 | V  |
| $V_{GS} =$   | 10  | V  |
| $R_{gon} =$  | 8   | Ω  |
| $R_{goff} =$ | 8   | Ω  |

**Figure 10** PFC MOSFET

**Typical switching times as a function of gate resistor**

$t = f(R_G)$

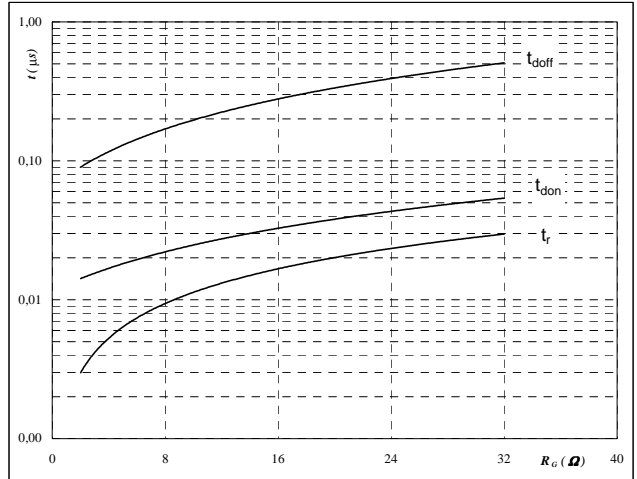

With an inductive load at

|            |     |    |
|------------|-----|----|
| $T_J =$    | 125 | °C |
| $V_{DS} =$ | 400 | V  |
| $V_{GS} =$ | 10  | V  |
| $I_C =$    | 15  | A  |

**Figure 11** PFC FWD

**Typical reverse recovery time as a function of collector current**

$t_{rr} = f(I_C)$

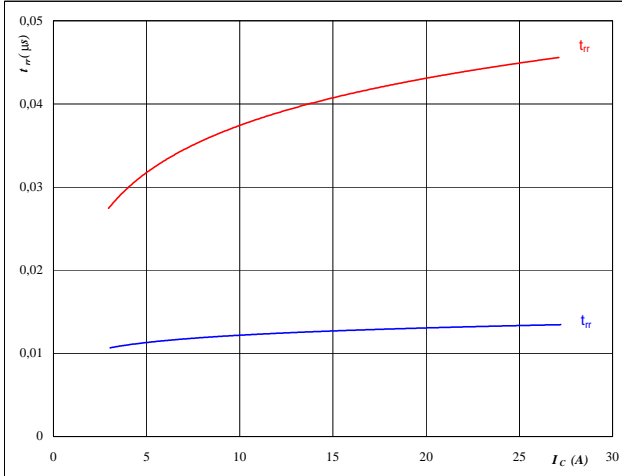

**At**

|             |        |    |
|-------------|--------|----|
| $T_J =$     | 25/125 | °C |
| $V_{CE} =$  | 400    | V  |
| $V_{GE} =$  | 10     | V  |
| $R_{gon} =$ | 8      | Ω  |

**Figure 12** PFC FWD

**Typical reverse recovery time as a function of IGBT turn on gate resistor**

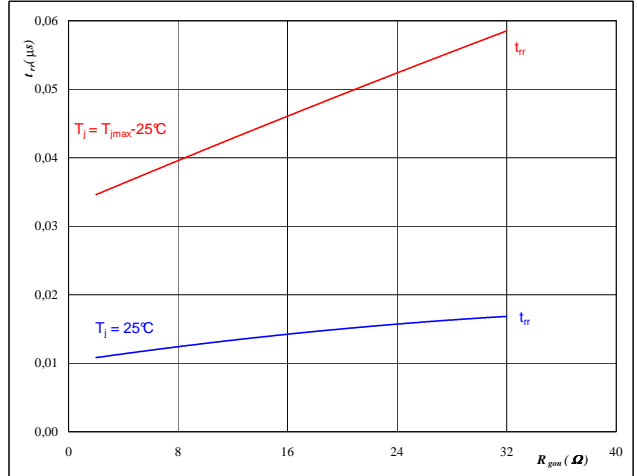
$t_{rr} = f(R_{gon})$

**At**

|            |        |    |
|------------|--------|----|
| $T_J =$    | 25/125 | °C |
| $V_R =$    | 400    | V  |
| $I_F =$    | 15     | A  |
| $V_{GS} =$ | 10     | V  |



**PFC**
**Figure 13** PFC FWD

**Typical reverse recovery charge as a function of collector current**

$$Q_{rr} = f(I_C)$$

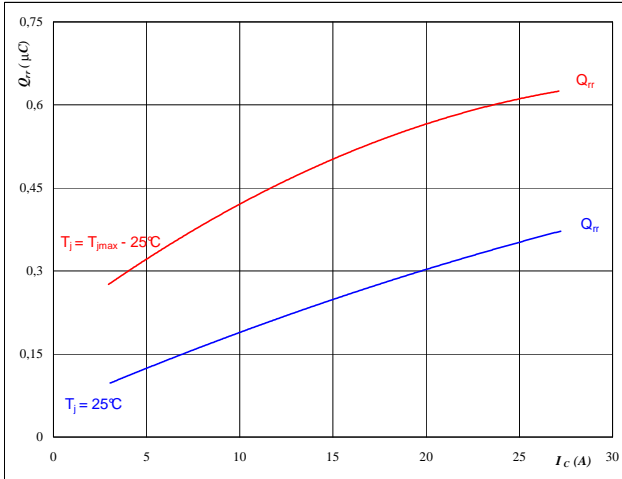

**At**

|             |        |    |
|-------------|--------|----|
| $T_j =$     | 25/125 | °C |
| $V_{CE} =$  | 400    | V  |
| $V_{GE} =$  | 10     | V  |
| $R_{gon} =$ | 8      | Ω  |

**Figure 14** PFC FWD

**Typical reverse recovery charge as a function of IGBT turn on gate resistor**

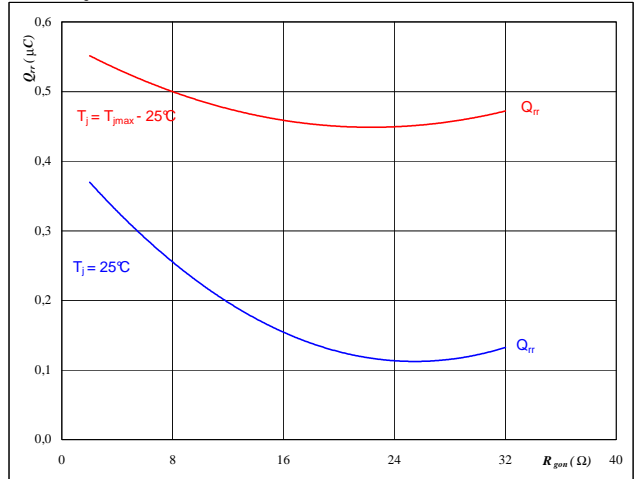
$$Q_{rr} = f(R_{gon})$$



**At**

|            |        |    |
|------------|--------|----|
| $T_j =$    | 25/125 | °C |
| $V_R =$    | 400    | V  |
| $I_F =$    | 15     | A  |
| $V_{GS} =$ | 10     | V  |

**Figure 15** PFC FWD

**Typical reverse recovery current as a function of collector current**

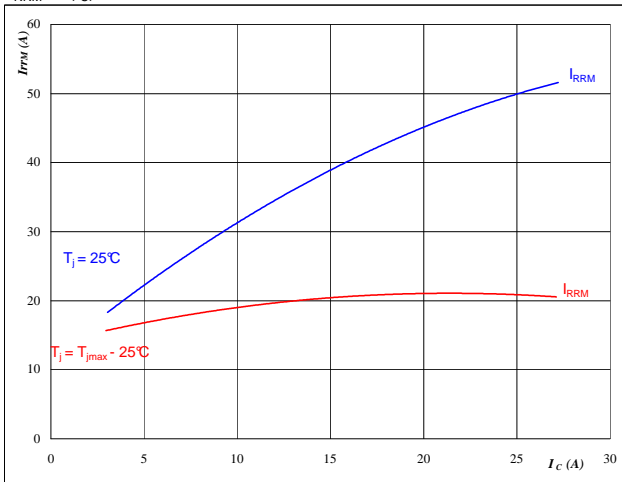
$$I_{RRM} = f(I_C)$$



**At**

|             |        |    |
|-------------|--------|----|
| $T_j =$     | 25/125 | °C |
| $V_{CE} =$  | 400    | V  |
| $V_{GE} =$  | 10     | V  |
| $R_{gon} =$ | 8      | Ω  |

**Figure 16** PFC FWD

**Typical reverse recovery current as a function of IGBT turn on gate resistor**

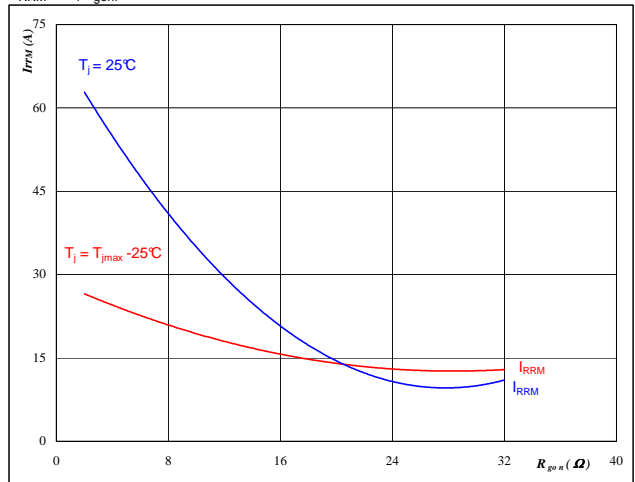
$$I_{RRM} = f(R_{gon})$$

**At**

|            |        |    |
|------------|--------|----|
| $T_j =$    | 25/125 | °C |
| $V_R =$    | 400    | V  |
| $I_F =$    | 15     | A  |
| $V_{GS} =$ | 10     | V  |

PFC

Figure 17 PFC FWD

Typical rate of fall of forward and reverse recovery current as a function of collector current

$dI_f/dt, dI_{rec}/dt = f(I_c)$

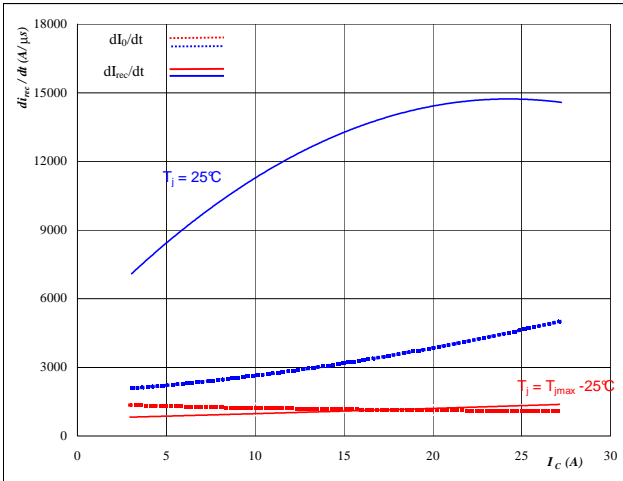

At  
 $T_j = 25/125 \text{ } ^\circ\text{C}$   
 $V_{CE} = 400 \text{ V}$   
 $V_{GE} = 10 \text{ V}$   
 $R_{gon} = 8,01 \text{ } \Omega$

Figure 18 PFC FWD

Typical rate of fall of forward and reverse recovery current as a function of IGBT turn on gate resistor

$dI_f/dt, dI_{rec}/dt = f(R_{gon})$

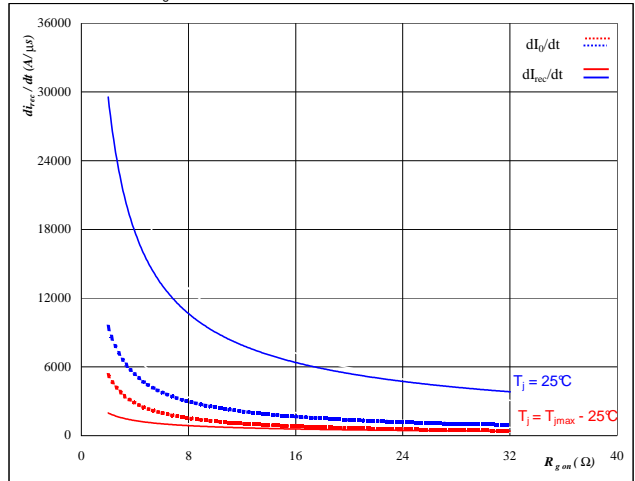

At  
 $T_j = 25/125 \text{ } ^\circ\text{C}$   
 $V_R = 400 \text{ V}$   
 $I_F = 15 \text{ A}$   
 $V_{GS} = 10 \text{ V}$

Figure 19 PFC MOSFET

IGBT/MOSFET transient thermal impedance as a function of pulse width

$Z_{thJH} = f(t_p)$

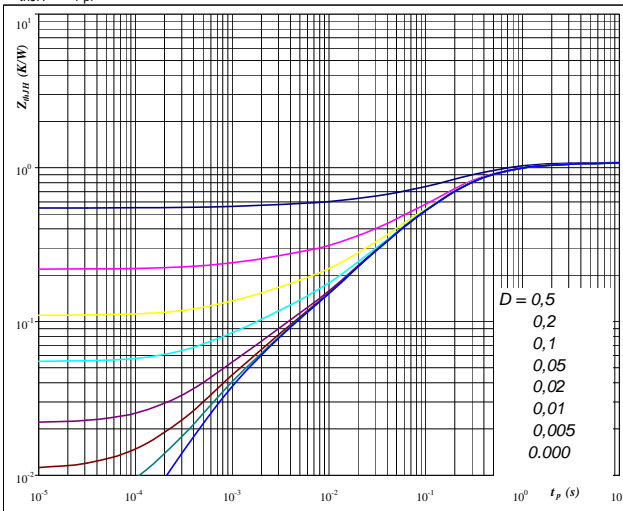

At  
 $D = t_p / T$   
 $R_{thJH} = 1,10 \text{ K/W}$        $R_{thJH} = 0,89 \text{ K/W}$

IGBT thermal model values

| Thermal grease |         | Phase change interface |         |
|----------------|---------|------------------------|---------|
| R (C/W)        | Tau (s) | R (C/W)                | Tau (s) |
| 0,04           | 14,82   | 0,03                   | 12,02   |
| 0,13           | 1,22    | 0,10                   | 0,99    |
| 0,59           | 0,22    | 0,47                   | 0,18    |
| 0,21           | 0,06    | 0,17                   | 0,05    |
| 0,09           | 0,01    | 0,07                   | 0,01    |
| 0,04           | 0,00    | 0,04                   | 0,00    |

Figure 20 PFC FWD

FWD transient thermal impedance as a function of pulse width

$Z_{thJH} = f(t_p)$

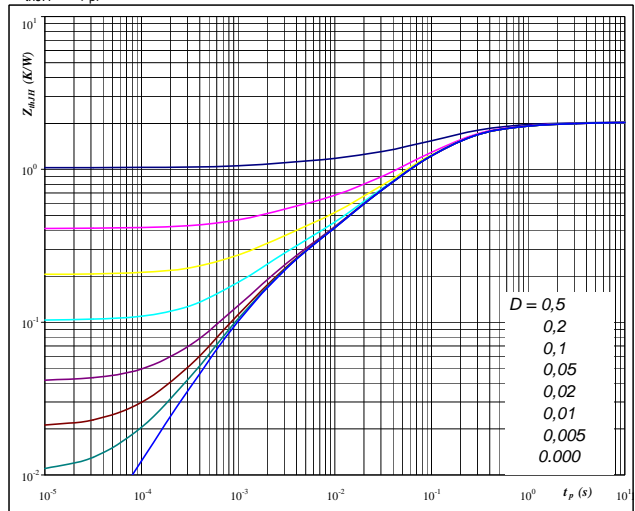

At  
 $D = t_p / T$   
 $R_{thJH} = 2,05 \text{ K/W}$        $R_{thJH} = 1,66 \text{ K/W}$

FWD thermal model values

| Thermal grease |         | Phase change interface |         |
|----------------|---------|------------------------|---------|
| R (C/W)        | Tau (s) | R (C/W)                | Tau (s) |
| 0,08           | 8,12    | 0,07                   | 6,58    |
| 0,23           | 0,73    | 0,19                   | 0,59    |
| 0,90           | 0,16    | 0,73                   | 0,13    |
| 0,49           | 0,05    | 0,40                   | 0,04    |
| 0,21           | 0,01    | 0,17                   | 0,01    |
| 0,14           | 0,00    | 0,11                   | 0,00    |

**PFC**
**Figure 21** PFC MOSFET

**Power dissipation as a function of heatsink temperature**

$$P_{tot} = f(T_h)$$

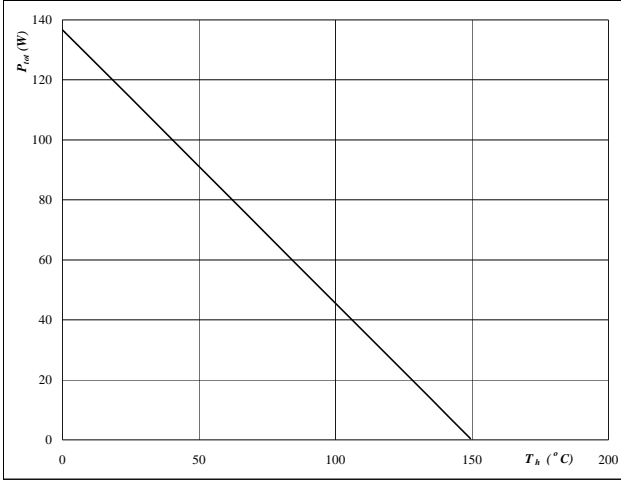
**At**  
 $T_j = 150$  °C

**Figure 22** PFC MOSFET

**Collector/Drain current as a function of heatsink temperature**

$$I_C = f(T_h)$$

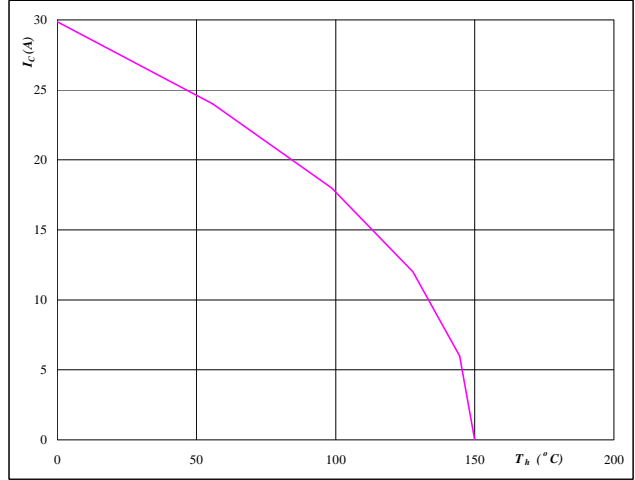
**At**  
 $T_j = 150$  °C  
 $V_{GS} = 10$  V

**Figure 23** PFC FWD

**Power dissipation as a function of heatsink temperature**

$$P_{tot} = f(T_h)$$

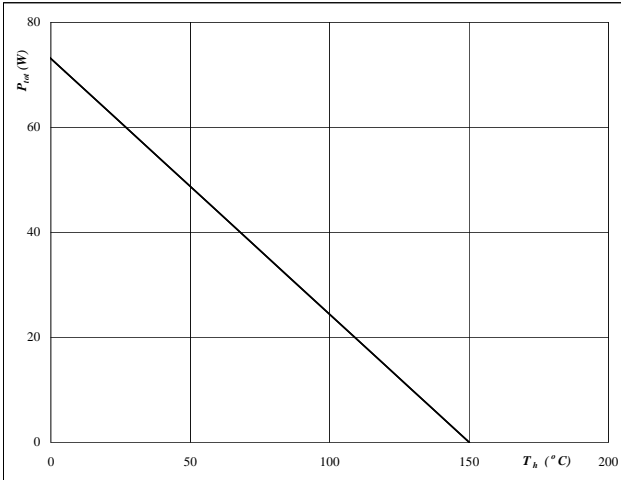
**At**  
 $T_j = 150$  °C

**Figure 24** PFC FWD

**Forward current as a function of heatsink temperature**

$$I_F = f(T_h)$$

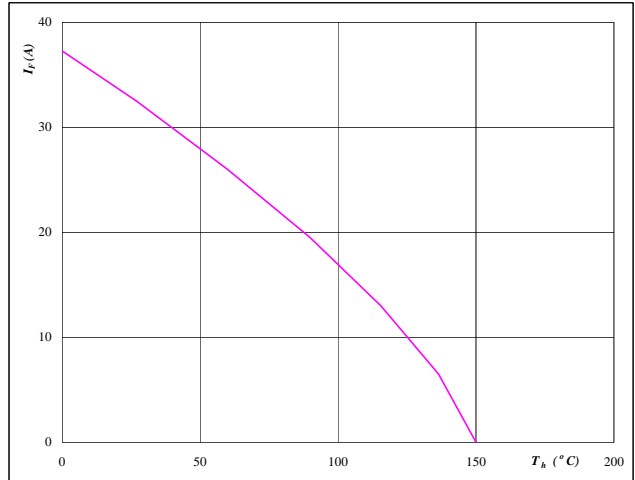
**At**  
 $T_j = 150$  °C

**PFC**
**Figure 25** PFC MOSFET

**Safe operating area as a function of drain-source voltage**

$$I_D = f(V_{DS})$$

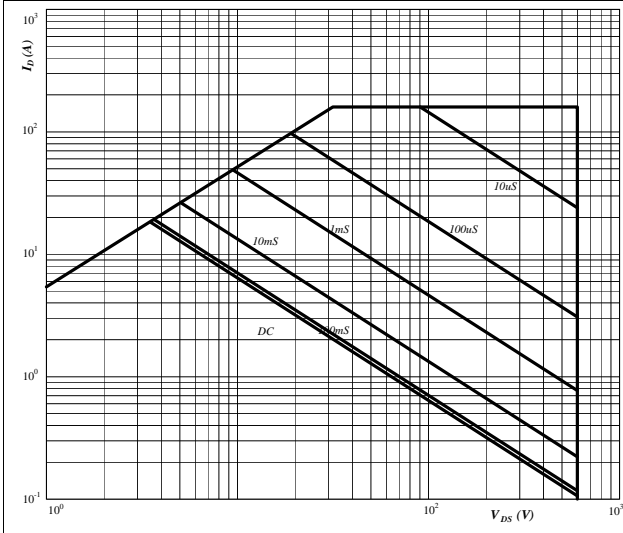

**At**  
 D = single pulse  
 $T_h = 80$  °C  
 $V_{GS} = 10$  V  
 $T_j = T_{jmax}$  °C

**Figure 26** PFC MOSFET

**Gate voltage vs Gate charge**

$$V_{GS} = f(Q_g)$$

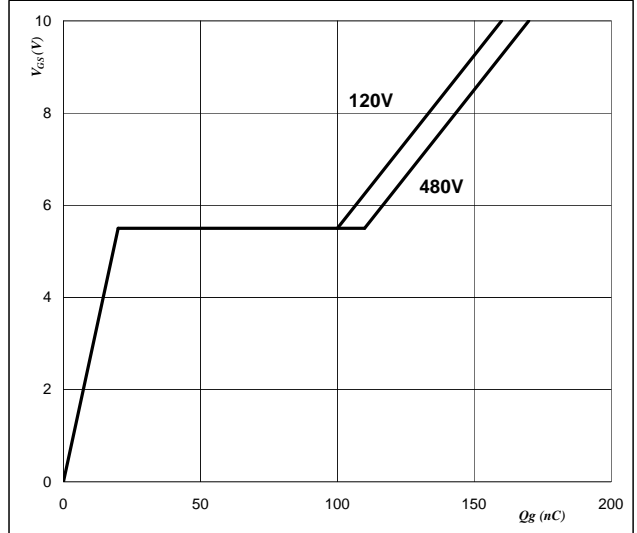

**At**  
 $I_D = 15$  A

**Figure 29** IGBT

**Reverse bias safe operating area**

$$I_C = f(V_{CE})$$

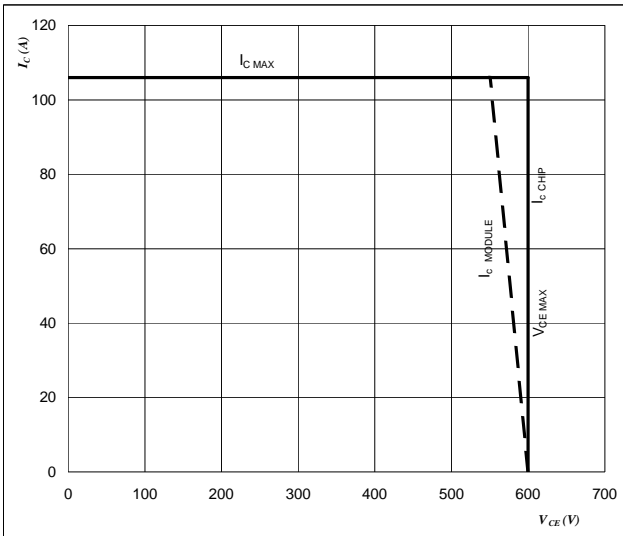

**At**  
 $T_j = T_{jmax} - 25$  °C  
 $U_{ocminus} = U_{ccplus}$   
 Switching mode : 3phase SPWM

## Input Rectifier Bridge

**Figure 1** Rectifier Diode

**Typical diode forward current as a function of forward voltage**

$$I_F = f(V_F)$$

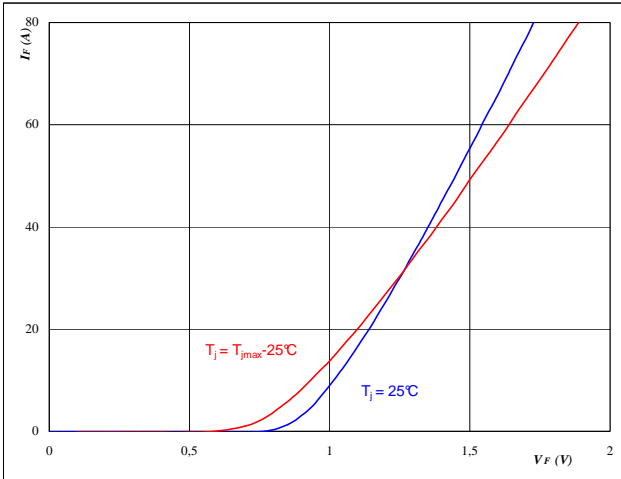

**At**

$$t_p = 250 \mu s$$

**Figure 2** Rectifier Diode

**Diode transient thermal impedance as a function of pulse width**

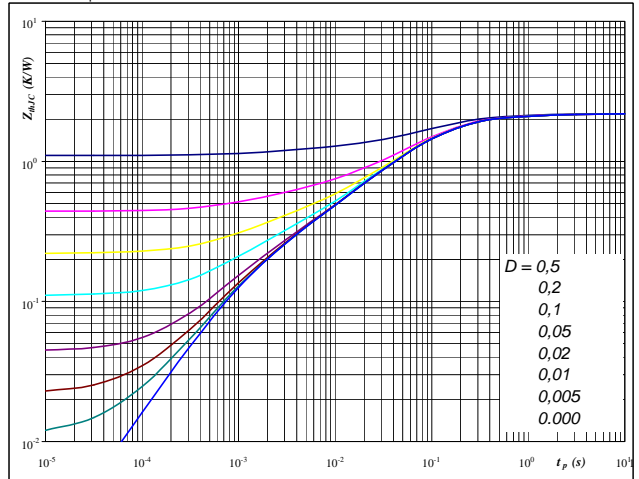
$$Z_{thJH} = f(t_p)$$

**At**

$$D = t_p / T$$

$$R_{thJH} = 2,20 \text{ K/W}$$

**Figure 3** Rectifier Diode

**Power dissipation as a function of heatsink temperature**

$$P_{tot} = f(T_h)$$

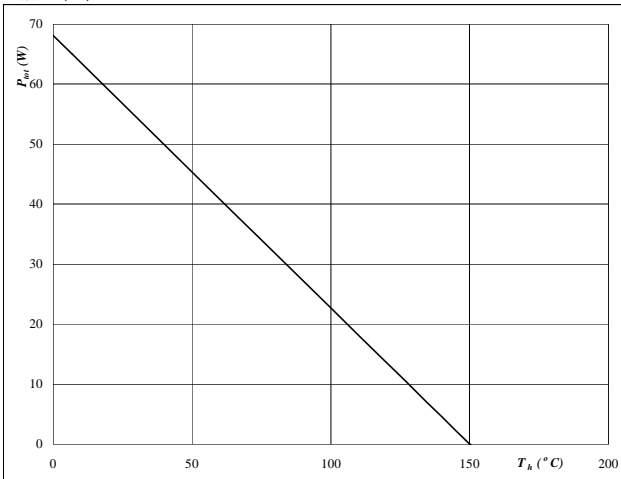

**At**

$$T_j = 150 \text{ } ^\circ\text{C}$$

**Figure 4** Rectifier Diode

**Forward current as a function of heatsink temperature**

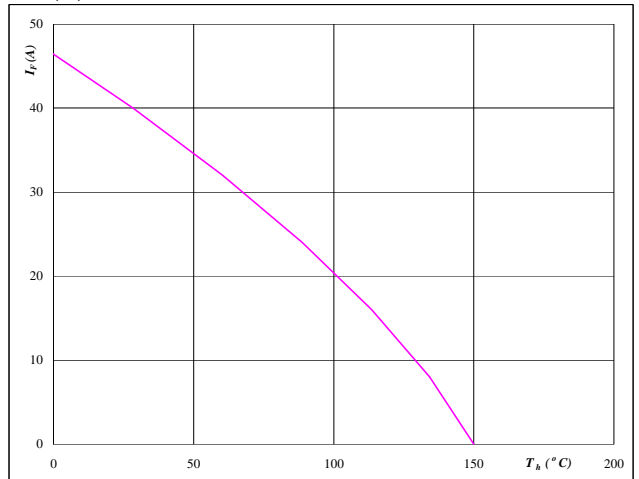
$$I_F = f(T_h)$$



**At**

$$T_j = 150 \text{ } ^\circ\text{C}$$

## Thermistor

**Figure 1** Thermistor

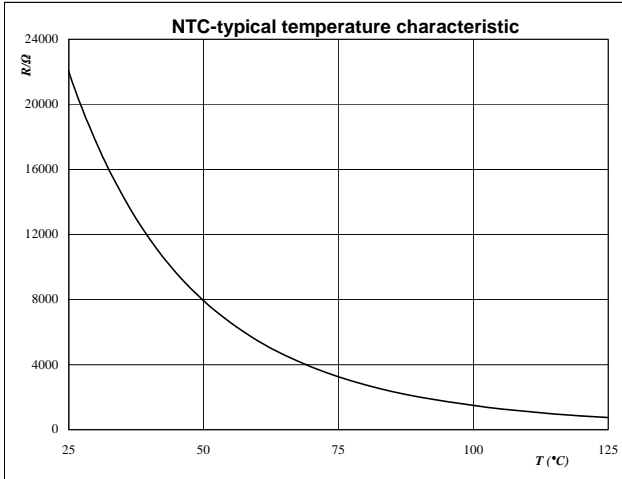
Typical NTC characteristic  
 as a function of temperature

 $R_T = f(T)$ 

**Figure 2** Thermistor

Typical NTC resistance values

$$R(T) = R_{25} \cdot e^{\left( B_{25/100} \left( \frac{1}{T} - \frac{1}{T_{25}} \right) \right)} \quad [\Omega]$$

| T [°C]     | R <sub>nom</sub> [Ω] | R <sub>min</sub> [Ω] | R <sub>max</sub> [Ω] | ΔR/R [±%] |
|------------|----------------------|----------------------|----------------------|-----------|
| -55        | 2089434,5            | 1506495,4            | 2672373,6            | 27,9      |
| 0          | 71804,2              | 59724,4              | 83884                | 16,8      |
| 10         | 43780,4              | 37094,4              | 50466,5              | 15,3      |
| 20         | 27484,6              | 23684,6              | 31284,7              | 13,8      |
| 25         | 22000                | 19109,3              | 24890,7              | 13,1      |
| 30         | 17723,3              | 15512,2              | 19934,4              | 12,5      |
| 60         | 5467,9               | 4980,6               | 5955,1               | 8,9       |
| 70         | 3848,6               | 3546                 | 4151,1               | 7,9       |
| 80         | 2757,7               | 2568,2               | 2947,1               | 6,9       |
| 90         | 2008,9               | 1889,7               | 2128,2               | 5,9       |
| <b>100</b> | <b>1486,1</b>        | <b>1411,8</b>        | <b>1560,4</b>        | <b>5</b>  |
| 150        | 400,2                | 364,8                | 435,7                | 8,8       |

## Switching Definitions Output Inverter

| General conditions |          |
|--------------------|----------|
| $T_j$              | = 125 °C |
| $R_{gon}$          | = 16 Ω   |
| $R_{goff}$         | = 16 Ω   |

**Figure 1** Output inverter IGBT

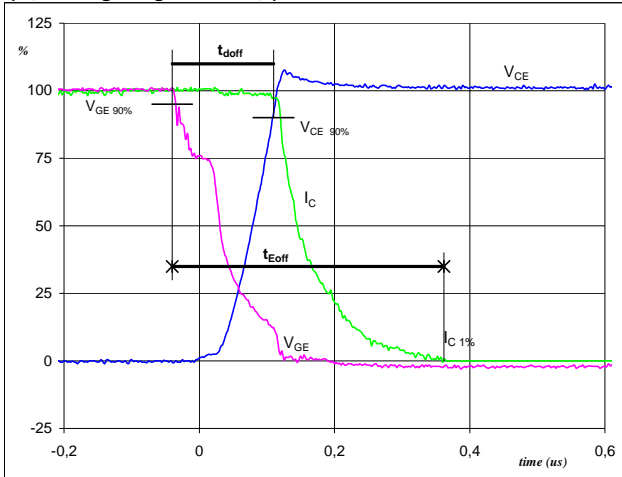
**Turn-off Switching Waveforms & definition of  $t_{doff}$ ,  $t_{Eoff}$**   
 ( $t_{Eoff}$  = integrating time for  $E_{off}$ )

|                 |   |      |    |
|-----------------|---|------|----|
| $V_{GE}(0\%)$   | = | -15  | V  |
| $V_{GE}(100\%)$ | = | 15   | V  |
| $V_C(100\%)$    | = | 400  | V  |
| $I_C(100\%)$    | = | 15   | A  |
| $t_{doff}$      | = | 0,14 | μs |
| $t_{Eoff}$      | = | 0,40 | μs |

**Figure 2** Output inverter IGBT

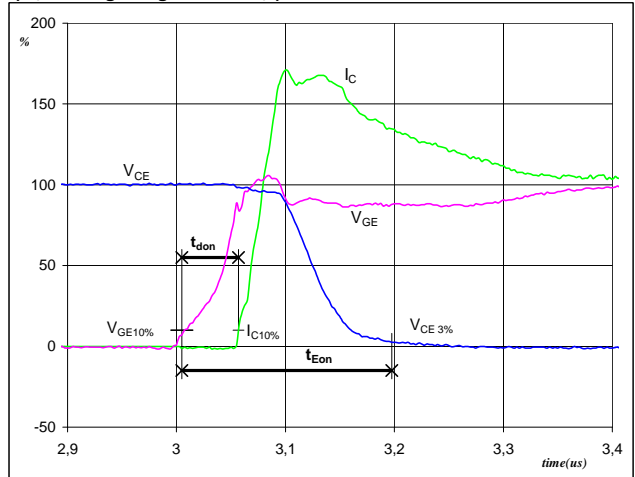
**Turn-on Switching Waveforms & definition of  $t_{don}$ ,  $t_{Eon}$**   
 ( $t_{Eon}$  = integrating time for  $E_{on}$ )

|                 |   |      |    |
|-----------------|---|------|----|
| $V_{GE}(0\%)$   | = | -15  | V  |
| $V_{GE}(100\%)$ | = | 15   | V  |
| $V_C(100\%)$    | = | 400  | V  |
| $I_C(100\%)$    | = | 15   | A  |
| $t_{don}$       | = | 0,05 | μs |
| $t_{Eon}$       | = | 0,19 | μs |

**Figure 3** Output inverter IGBT

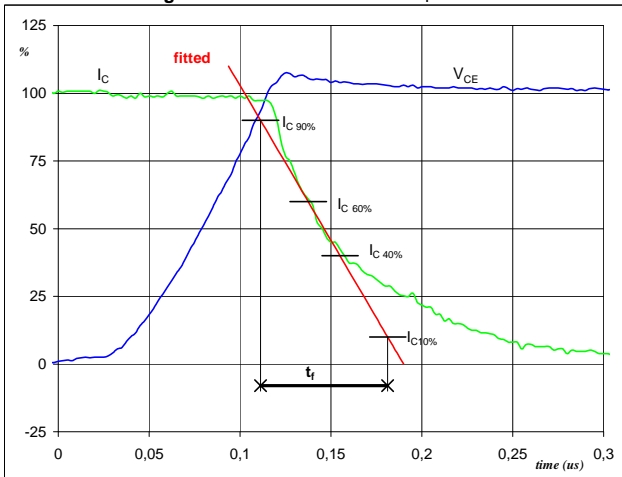
**Turn-off Switching Waveforms & definition of  $t_f$** 

|              |   |      |    |
|--------------|---|------|----|
| $V_C(100\%)$ | = | 400  | V  |
| $I_C(100\%)$ | = | 15   | A  |
| $t_f$        | = | 0,08 | μs |

**Figure 4** Output inverter IGBT

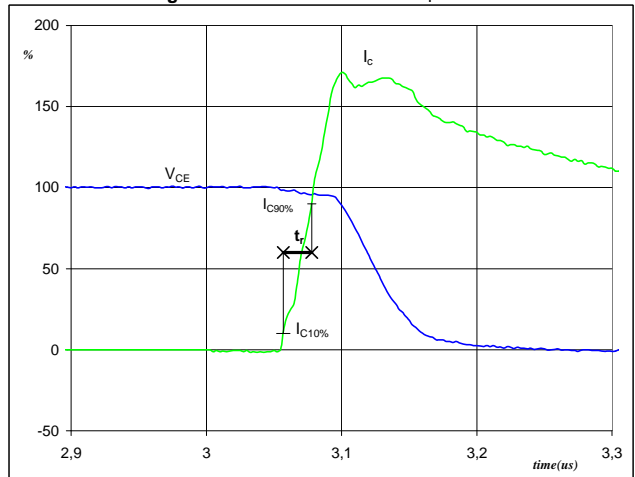
**Turn-on Switching Waveforms & definition of  $t_r$** 

|              |   |      |    |
|--------------|---|------|----|
| $V_C(100\%)$ | = | 400  | V  |
| $I_C(100\%)$ | = | 15   | A  |
| $t_r$        | = | 0,02 | μs |

## Switching Definitions Output Inverter

**Figure 5** Output inverter IGBT

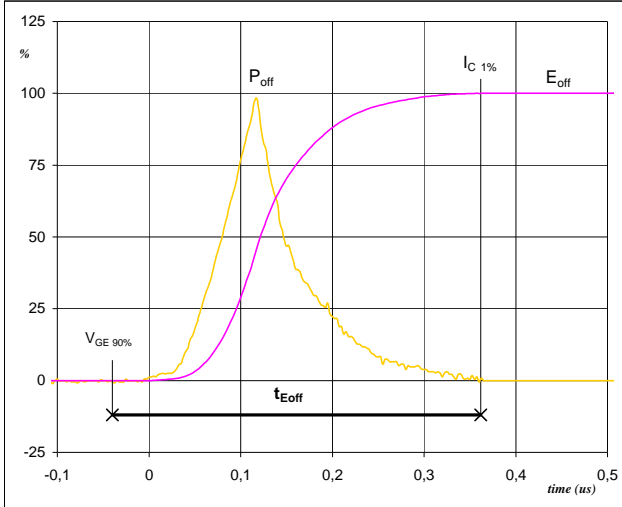
**Turn-off Switching Waveforms & definition of  $t_{Eoff}$** 

$P_{off} (100\%) = 5,97 \text{ kW}$   
 $E_{off} (100\%) = 0,56 \text{ mJ}$   
 $t_{Eoff} = 0,40 \text{ }\mu\text{s}$

**Figure 6** Output inverter IGBT

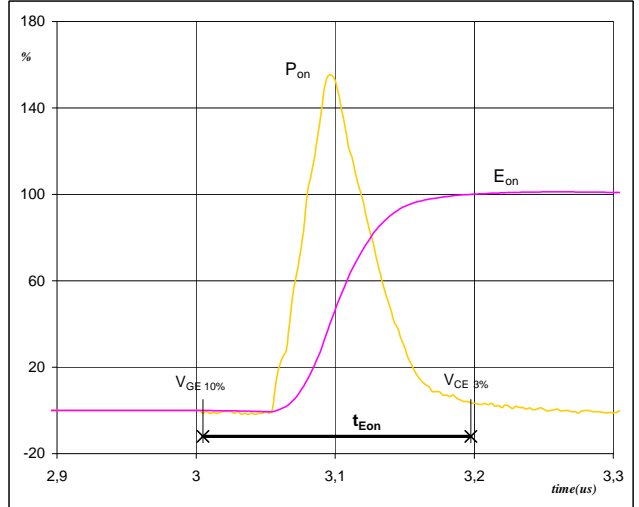
**Turn-on Switching Waveforms & definition of  $t_{Eon}$** 

$P_{on} (100\%) = 5,97 \text{ kW}$   
 $E_{on} (100\%) = 0,53 \text{ mJ}$   
 $t_{Eon} = 0,19 \text{ }\mu\text{s}$

**Figure 7** Output inverter IGBT

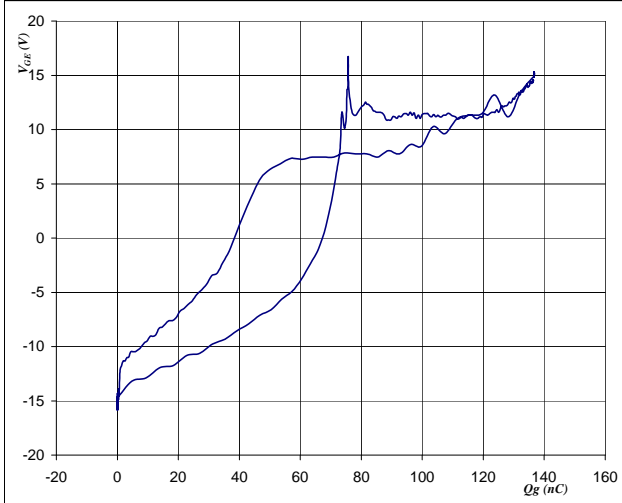
**Gate voltage vs Gate charge (measured)**

$V_{GEoff} = -15 \text{ V}$   
 $V_{GEon} = 15 \text{ V}$   
 $V_C (100\%) = 400 \text{ V}$   
 $I_C (100\%) = 15 \text{ A}$   
 $Q_g = 139,20 \text{ nC}$

**Figure 8** Output inverter FWD

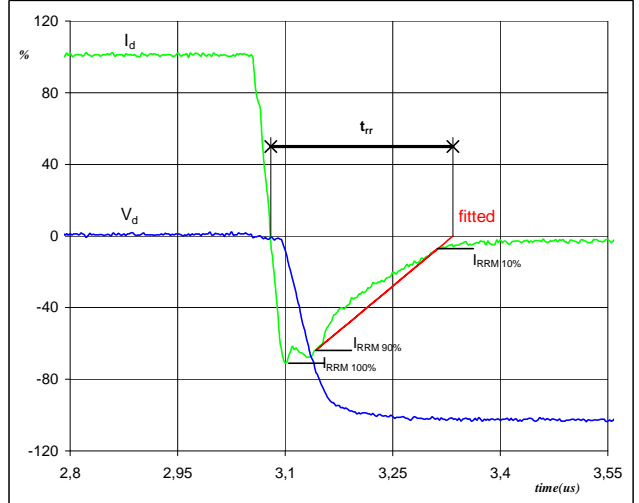
**Turn-off Switching Waveforms & definition of  $t_{rr}$** 

$V_d (100\%) = 400 \text{ V}$   
 $I_d (100\%) = 15 \text{ A}$   
 $I_{RRM} (100\%) = -11 \text{ A}$   
 $t_{rr} = 0,26 \text{ }\mu\text{s}$



## Switching Definitions Output Inverter

**Figure 9** Output inverter FWD

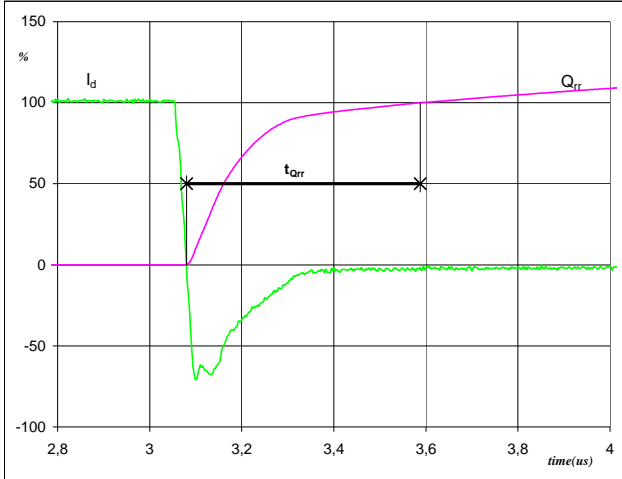
**Turn-on Switching Waveforms & definition of  $t_{Qrr}$**   
 ( $t_{Qrr}$  = integrating time for  $Q_{rr}$ )

|                   |      |               |
|-------------------|------|---------------|
| $I_d$ (100%) =    | 15   | A             |
| $Q_{rr}$ (100%) = | 1,40 | $\mu\text{C}$ |
| $t_{Qrr}$ =       | 0,51 | $\mu\text{s}$ |

**Figure 10** Output inverter FWD

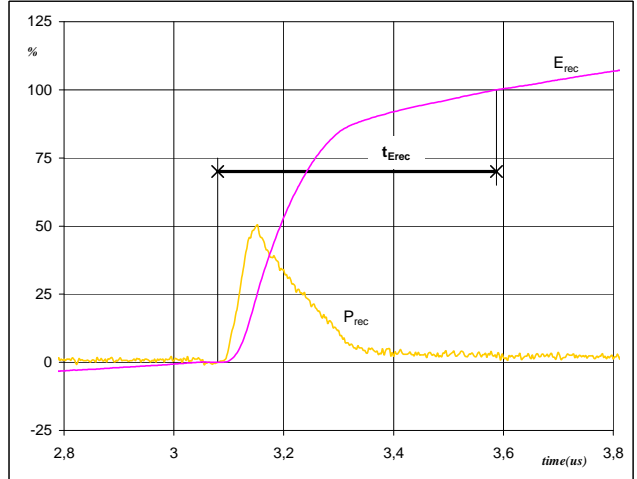
**Turn-on Switching Waveforms & definition of  $t_{Erec}$**   
 ( $t_{Erec}$  = integrating time for  $E_{rec}$ )

|                    |      |               |
|--------------------|------|---------------|
| $P_{rec}$ (100%) = | 5,97 | kW            |
| $E_{rec}$ (100%) = | 0,40 | mJ            |
| $t_{Erec}$ =       | 0,51 | $\mu\text{s}$ |

## Switching Definitions PFC

| General conditions |          |
|--------------------|----------|
| $T_j$              | = 125 °C |
| $R_{gon}$          | = 8 Ω    |
| $R_{goff}$         | = 8 Ω    |

Figure 1 PFC MOSFET

Turn-off Switching Waveforms & definition of  $t_{doff}$ ,  $t_{Eoff}$   
( $t_{Eoff}$  = integrating time for  $E_{off}$ )

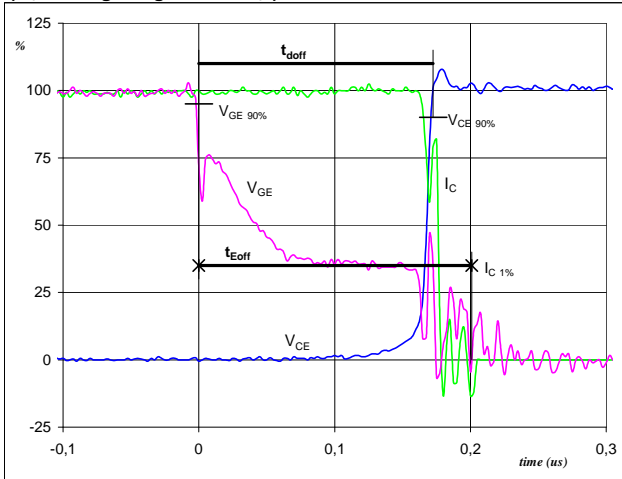

|                   |      |    |
|-------------------|------|----|
| $V_{GE}(0\%) =$   | 0    | V  |
| $V_{GE}(100\%) =$ | 10   | V  |
| $V_C(100\%) =$    | 400  | V  |
| $I_C(100\%) =$    | 15   | A  |
| $t_{doff} =$      | 0,17 | μs |
| $t_{Eoff} =$      | 0,20 | μs |

Figure 2 PFC MOSFET

Turn-on Switching Waveforms & definition of  $t_{don}$ ,  $t_{Eon}$   
( $t_{Eon}$  = integrating time for  $E_{on}$ )

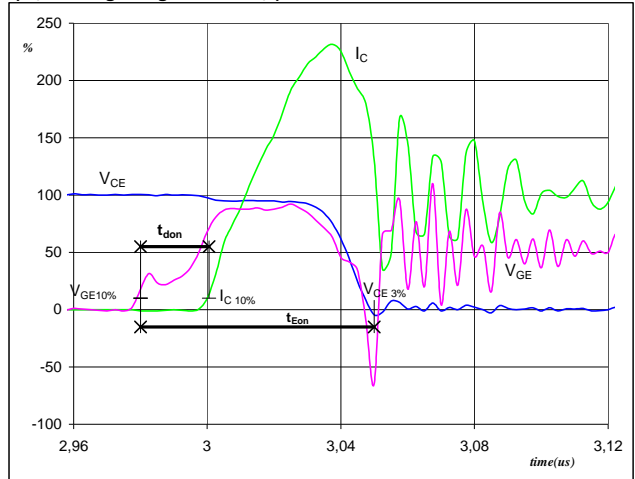

|                   |      |    |
|-------------------|------|----|
| $V_{GE}(0\%) =$   | 0    | V  |
| $V_{GE}(100\%) =$ | 10   | V  |
| $V_C(100\%) =$    | 400  | V  |
| $I_C(100\%) =$    | 15   | A  |
| $t_{don} =$       | 0,02 | μs |
| $t_{Eon} =$       | 0,07 | μs |

Figure 3 PFC MOSFET

Turn-off Switching Waveforms & definition of  $t_f$

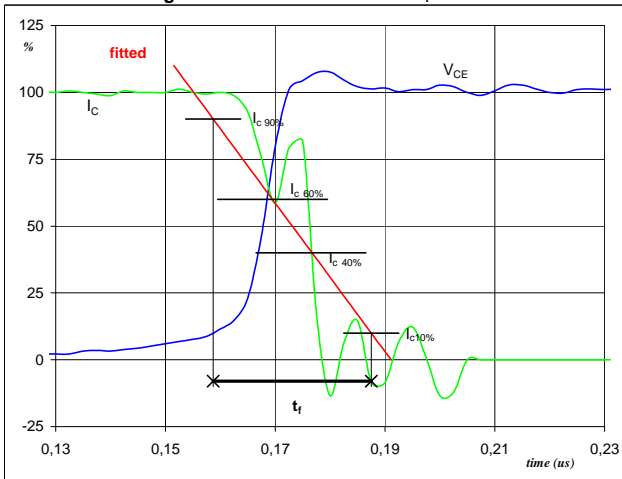

|                |        |    |
|----------------|--------|----|
| $V_C(100\%) =$ | 400    | V  |
| $I_C(100\%) =$ | 15     | A  |
| $t_f =$        | 0,0288 | μs |

Figure 4 PFC MOSFET

Turn-on Switching Waveforms & definition of  $t_r$

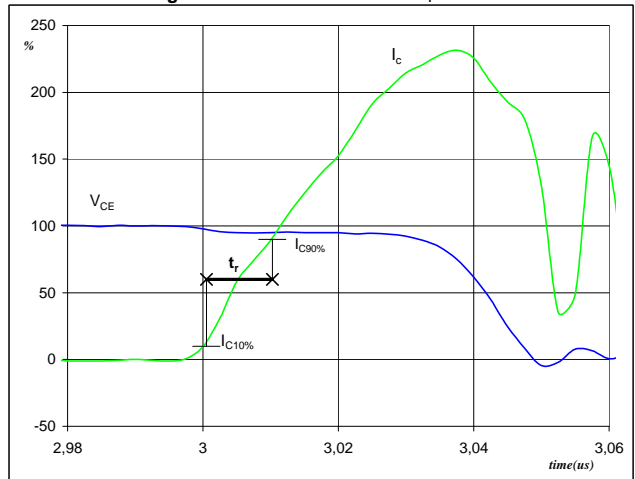

|                |        |    |
|----------------|--------|----|
| $V_C(100\%) =$ | 400    | V  |
| $I_C(100\%) =$ | 15     | A  |
| $t_r =$        | 0,0100 | μs |

## Switching Definitions PFC

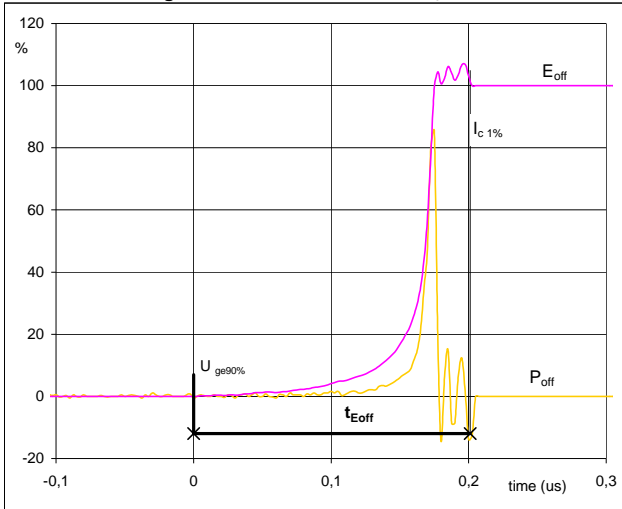
**Figure 5** PFC MOSFET  
**Turn-off Switching Waveforms & definition of  $t_{Eoff}$** 

$P_{off} (100\%) = 6,04 \text{ kW}$   
 $E_{off} (100\%) = 0,06 \text{ mJ}$   
 $t_{Eoff} = 0,20 \text{ } \mu\text{s}$

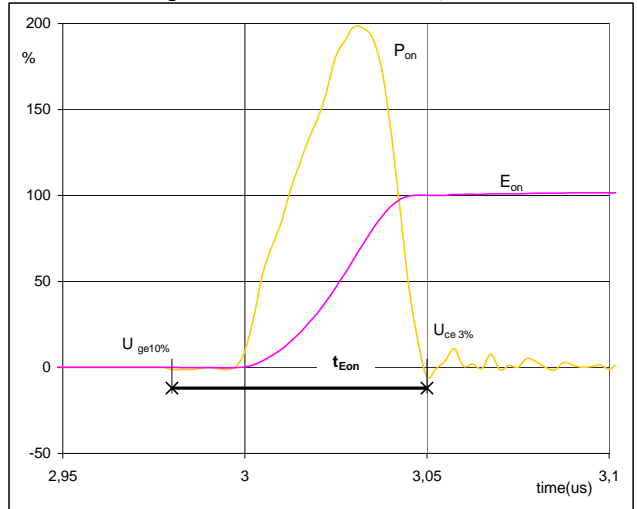
**Figure 6** PFC MOSFET  
**Turn-on Switching Waveforms & definition of  $t_{Eon}$** 

$P_{on} (100\%) = 6,0368 \text{ kW}$   
 $E_{on} (100\%) = 0,37 \text{ mJ}$   
 $t_{Eon} = 0,07 \text{ } \mu\text{s}$

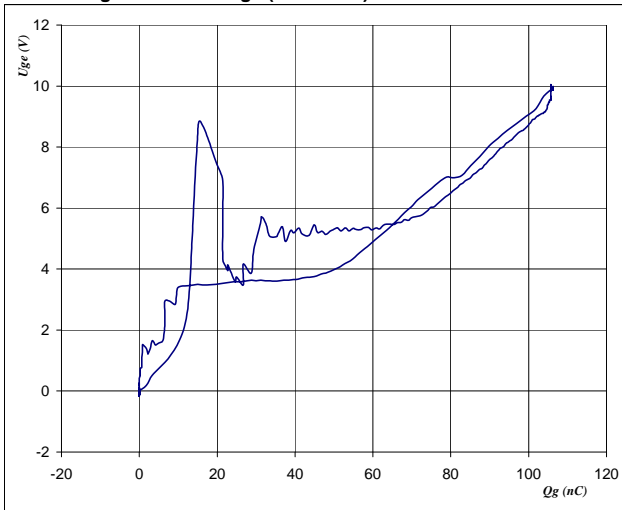
**Figure 7** PFC MOSFET  
**Gate voltage vs Gate charge (measured)**

$V_{GEoff} = 0 \text{ V}$   
 $V_{GEon} = 10 \text{ V}$   
 $V_C (100\%) = 400 \text{ V}$   
 $I_C (100\%) = 15 \text{ A}$   
 $Q_g = 106,24 \text{ nC}$

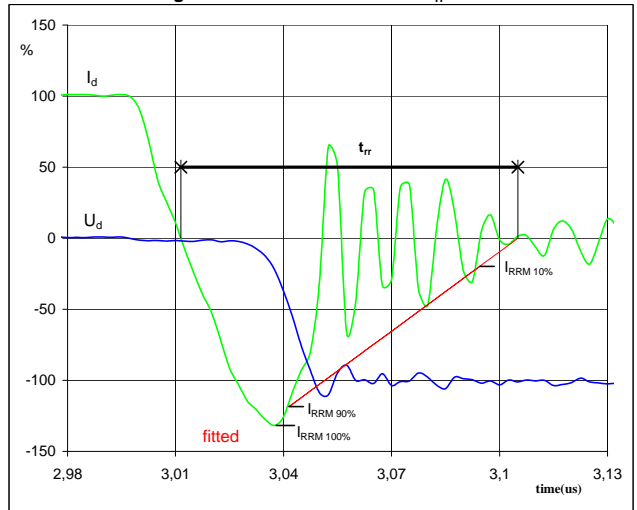
**Figure 8** PFC FWD  
**Turn-off Switching Waveforms & definition of  $t_{rr}$** 

$V_d (100\%) = 400 \text{ V}$   
 $I_d (100\%) = 15 \text{ A}$   
 $I_{RRM} (100\%) = -20 \text{ A}$   
 $t_{rr} = 0,04 \text{ } \mu\text{s}$

## Switching Definitions PFC

**Figure 9** PFC FWD

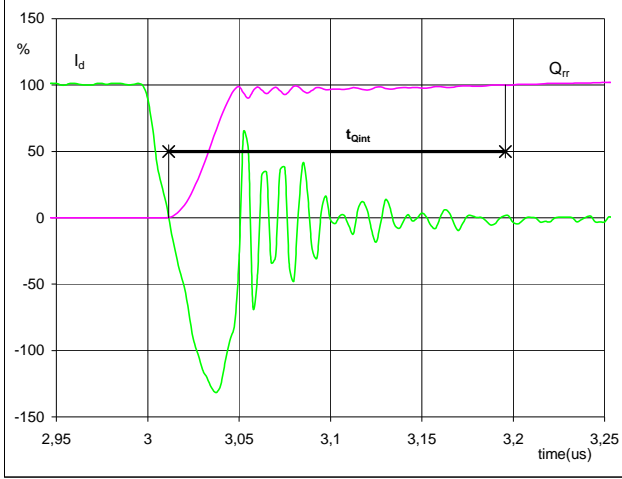
**Turn-on Switching Waveforms & definition of  $t_{Qrr}$**   
 ( $t_{Qrr}$ = integrating time for  $Q_{rr}$ )

|                   |      |               |
|-------------------|------|---------------|
| $I_d$ (100%) =    | 15   | A             |
| $Q_{rr}$ (100%) = | 0,48 | $\mu\text{C}$ |
| $t_{Qint}$ =      | 0,18 | $\mu\text{s}$ |

**Figure 10** PFC FWD

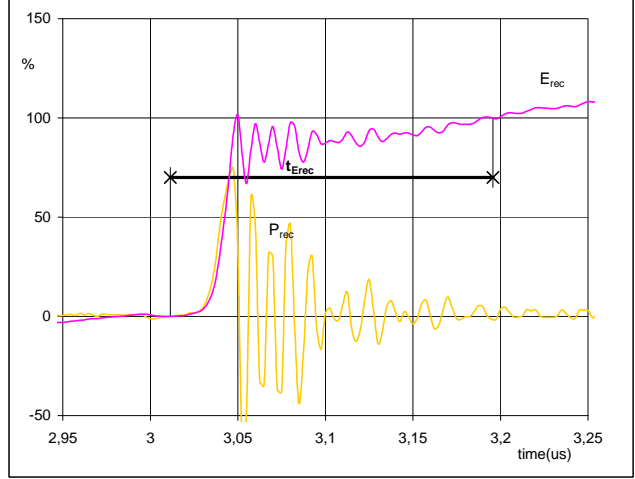
**Turn-on Switching Waveforms & definition of  $t_{Erec}$**   
 ( $t_{Erec}$ = integrating time for  $E_{rec}$ )

|                    |      |               |
|--------------------|------|---------------|
| $P_{rec}$ (100%) = | 6,04 | kW            |
| $E_{rec}$ (100%) = | 0,05 | mJ            |
| $t_{Erec}$ =       | 0,18 | $\mu\text{s}$ |

### Ordering Code and Marking - Outline - Pinout

#### Ordering Code & Marking

| Version                            | Ordering Code         | in DataMatrix as | in packaging barcode as |
|------------------------------------|-----------------------|------------------|-------------------------|
| without thermal paste 17mm housing | 10-F006PPA015SB-M684B | M684B            | M684B                   |

#### Outline

| Pin table |      |       |
|-----------|------|-------|
| Pin       | X    | Y     |
| 1         | 335  | 0     |
| 2         | 307  | 0     |
| 3         | 28   | 0     |
| 4         | 253  | 0     |
| 5         | 226  | 0     |
| 6         | 199  | 0     |
| 7         | 172  | 0     |
| 8         | 145  | 0     |
| 9         | 118  | 0     |
| 10        | 91   | 0     |
| 11        | 64   | 0     |
| 12        | 37   | 0     |
| 13        | 10   | 0     |
| 14        | -17  | 8,5   |
| 15        | -44  | 17,0  |
| 16        | -71  | 25,5  |
| 17        | -98  | 34,0  |
| 18        | -125 | 42,5  |
| 19        | -152 | 51,0  |
| 20        | -179 | 59,5  |
| 21        | -206 | 68,0  |
| 22        | -233 | 76,5  |
| 23        | -260 | 85,0  |
| 24        | -287 | 93,5  |
| 25        | -314 | 102,0 |
| 26        | -341 | 110,5 |
| 27        | -368 | 119,0 |

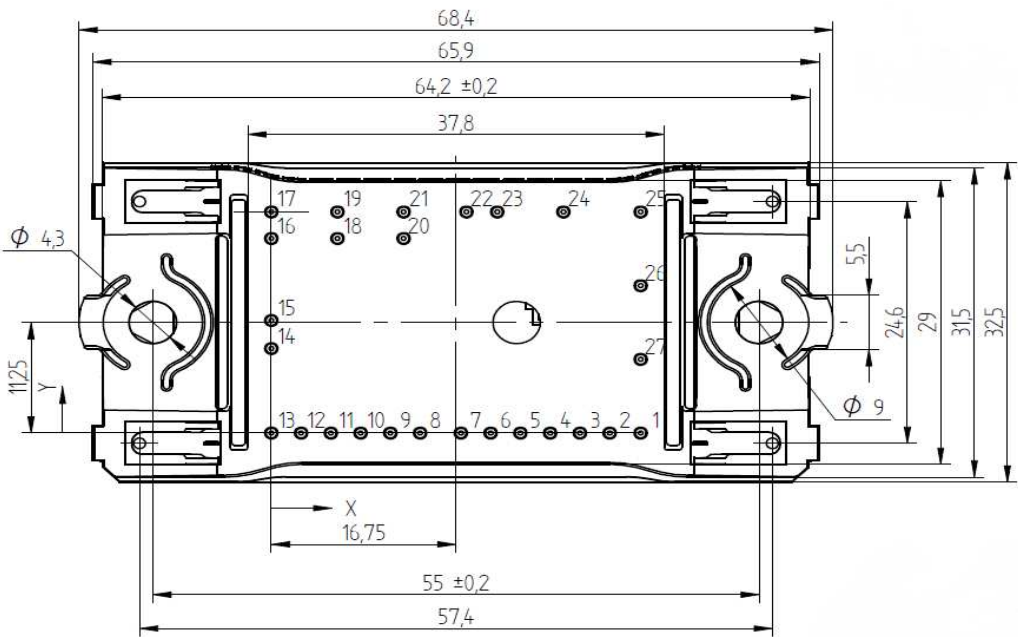

#### Pinout

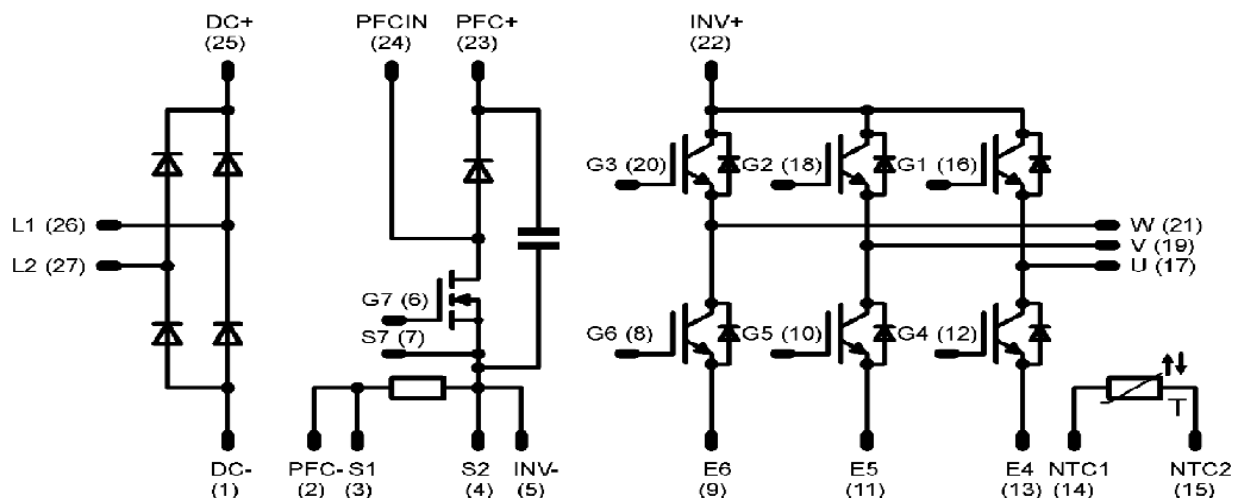

**PRODUCT STATUS DEFINITIONS**

| Datasheet Status | Product Status         | Definition   |
|------------------|------------------------|--|
| Target           | Formative or In Design | This datasheet contains the design specifications for product development. Specifications may change in any manner without notice. The data contained is exclusively intended for technically trained staff.   |
| Preliminary      | First Production       | This datasheet contains preliminary data, and supplementary data may be published at a later date. Vincotech reserves the right to make changes at any time without notice in order to improve design. The data contained is exclusively intended for technically trained staff. |
| Final            | Full Production        | This datasheet contains final specifications. Vincotech reserves the right to make changes at any time without notice in order to improve design. The data contained is exclusively intended for technically trained staff.  |

**DISCLAIMER**

The information given in this datasheet describes the type of component and does not represent assured characteristics. For tested values please contact Vincotech. Vincotech reserves the right to make changes without further notice to any products herein to improve reliability, function or design. Vincotech does not assume any liability arising out of the application or use of any product or circuit described herein; neither does it convey any license under its patent rights, nor the rights of others.

**LIFE SUPPORT POLICY**

Vincotech products are not authorised for use as critical components in life support devices or systems without the express written approval of Vincotech.

As used herein:

1. Life support devices or systems are devices or systems which, (a) are intended for surgical implant into the body, or (b) support or sustain life, or (c) whose failure to perform when properly used in accordance with instructions for use provided in labelling can be reasonably expected to result in significant injury to the user.
2. A critical component is any component of a life support device or system whose failure to perform can be reasonably expected to cause the failure of the life support device or system, or to affect its safety or effectiveness.