

Engineering Specification

TCF03025FH35002A

Features and Application

TCF03025FH35002A is a thin film common mode filter designed to suppress common mode noise for high speed differential data lines, such as USB 2.0 IEEE 1394, LVDS,DVI,HDMI,and MIPI

These differential interfaces can be used in personal computers,note books,mibile phone,LCD/PDP/DLP TVs,Blu-ray/DVD players, personal handheld equipments,etc.

TCF 03025 FH35002A is meet RoHs standards.

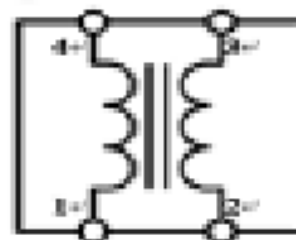

ABSOLUTE MAXIMUM RATINGS

PARAMETER	PARAMETER	RATING	UNITS
Rated Voltage	VDC	5	V
Operating Temperature		-25~85	°C
Rated Current	IDC	100	mA
Lead Soldering Temperature	TSOL	260(10sec.)	°C

ELECTRICAL CHARACTERISTICS

PARAMETER	MIN	TYP	MAX	UNITS
Common Mode Impedance (at 100MHz)	25	35	50	Ω
Cut-off Frequency		4.0		GHz
DC Resistance	1.0	1.5	2.0	Ω
Insulation Resistance	10			MΩ

Engineering Specification

TCF03025FH35002A

PART NUMBER CODE

TCF	03025	FH	350	02	A	□□
1	2	3	4	5	6	7

- 1: Product Type : TCF= Thin Film Common Mode Filter
- 2: EIA Dimension Code
- 3: Speed Identification Code: FH=High Speed
- 4: Impedance(at 100MHz):350=35Ω
- 5: Line Code:02=2 lines
- 6: Specialized Specification Code
- 7: Control code

TYPICAL CHARACTERISTIC

Fig1. IMPEDANCE vs. FREQUENCY CHARACTERISTICS

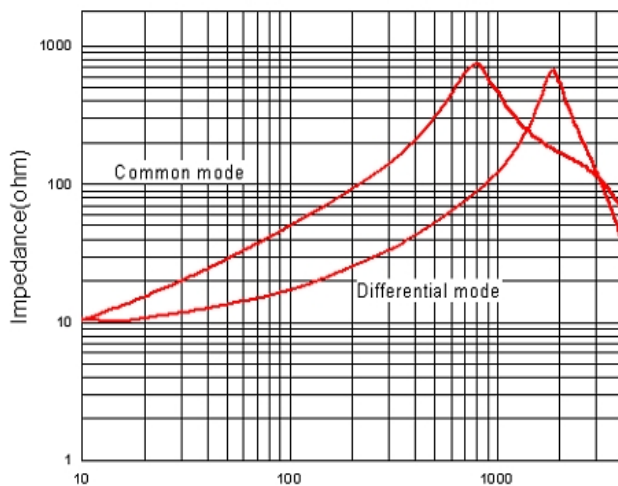
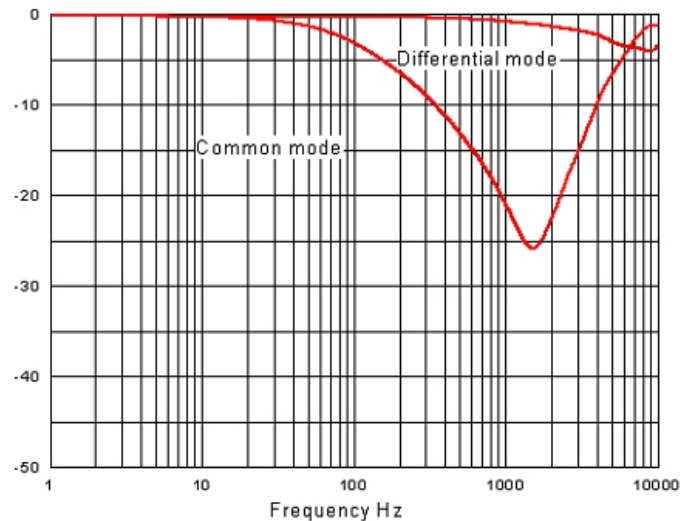

Fig2. INSERTION LOSS vs. FREQUENCY CHARACTERISTICS



Test Instrument : HP4291A Impedance/Material Analyzer
Test Instrument : Agilent E5071C ENAL-L Network Analyzer

Engineering Specification

TCF03025FH35002A

SHARES AND DIMENSIONS

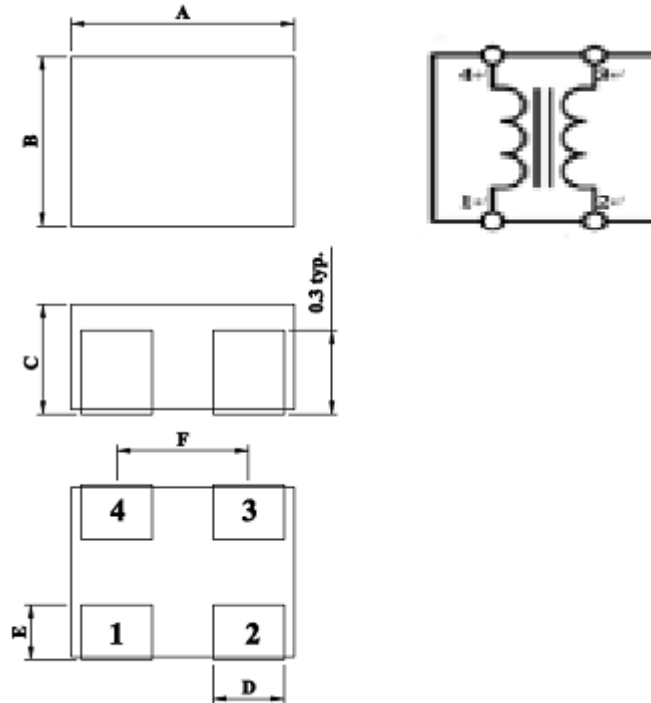

Series	A	B	C	D	E	F
TCF 03025	0.85±0.05	0.65±0.05	0.4±0.05	0.27±0.1	0.2±0.1	0.5±0.1

CIRCUIT CONFIGURATION & LAYOUT PAD

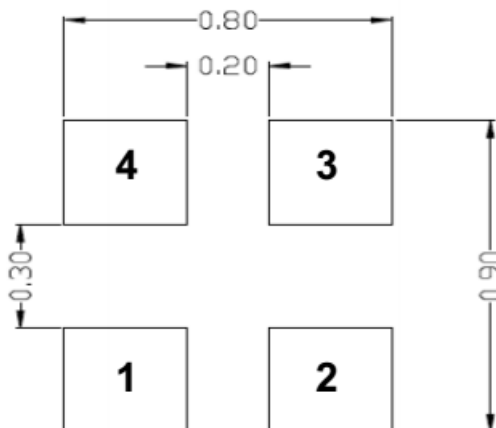

Dimensions in mm

Engineering Specification

TCF03025FH35002A

TAPE AND REEL SPECIFICATIONS / TAPING DIMENSIONS

Type : Paper Carrier

Unit : mm

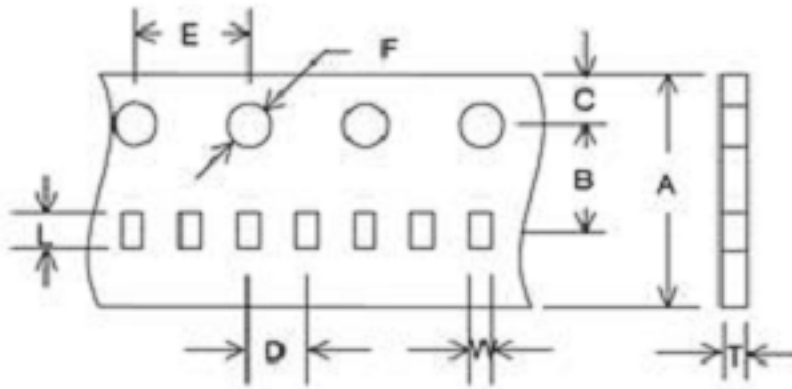

A	8±0.1
B	3.5±0.05
C	1.75±0.05
D	2±0.05
E	4±0.1
F	1.55±0.05
L	1.04±0.03
W	0.78±0.03
T	0.60±0.03

REEL DIMENSIONS

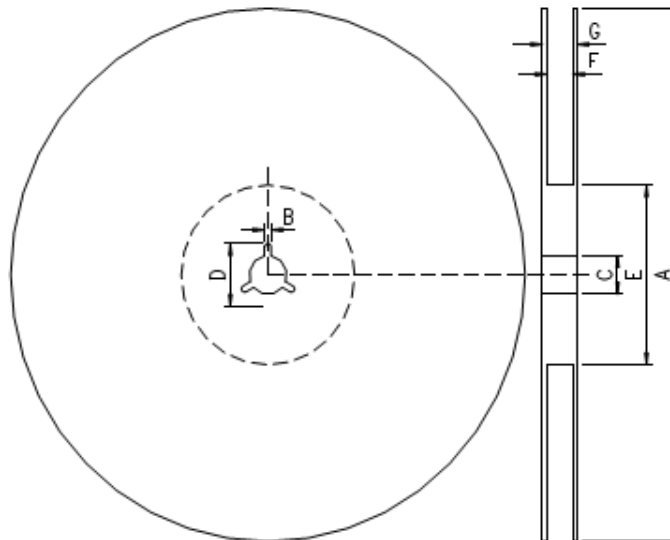

A	178.0±2.0
B	2.0±0.5
C	13.0±0.5
D	21.0±0.8
E	62.0±1.5
F	9.0±0.5
G	13.0±1.0

*Standard quantity : 10,000 pcs/Reel

Engineering Specification

TCF03025FH35002A

RECOMMENDED REFLOW SOLDERING

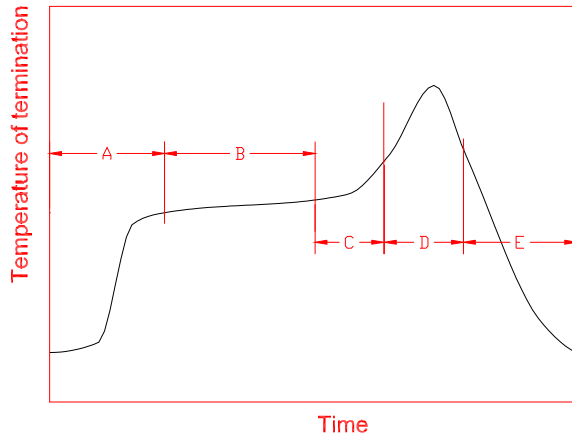

A	1 st rising temperature	The normal to Preheating temperature	30s to 60s
B	Preheating	140°C to 160°C	60s to 120s
C	2 nd rising temperature	Preheating to 200°C	20s to 40s
D	Main heating	if 220°C	50s ~ 60s
		if 230°C	40s ~ 50s
		if 240°C	30s ~ 40s
		if 250°C	20s ~ 40s
		if 260°C	20s ~ 40s
E	Regular cooling	200°C to 100°C	1°C/s ~ 4°C/s

- According to J-STD-020C