



A Type



B Type

Size:  
1.41 x 0.75 x 0.86 inches  
35.7 x 19.0 x 22.0 mm



### FEATURES

- RoHS Compliant
- Isolation Class II
- 3 Watts Output Power
- Single Outputs
- Low Output Ripple & Noise
- UL/cUL and CE Approvals
- Fully Encapsulated Plastic Case
- Switching Power Module for PCB Mounting
- Universal Input Voltage Range: 90-264VAC (120-370VDC)
- No Load Power Consumption < 0.3W
- Short Circuit, Over Power, and Over Voltage Protection
- Wide Operating Temperature Range: -40°C to +85°C

### DESCRIPTION

The PSAIC series of AC/DC power supplies provides 3 watts of output power in a 1.41" x 0.75" x 0.86" encapsulated PCB mountable package. This series consists of single output models with a universal input range of 90-264VAC or 120-370VDC. Some features include low ripple and noise, -40°C to +85°C operating temperature range, and < 0.3W no load power consumption. All supplies are over power, over voltage, and short circuit protected. The PSAIC series has two types of mechanical options available. All models are RoHS compliant and have UL/cUL and CE safety approvals.

### MODEL SELECTION TABLE

Model Number <sup>(1)</sup>	Input Voltage Range	Output Voltage	Output Current	Output Power	Ripple & Noise	Efficiency	Maximum Capacitive Load
PSAIC-3.3Sx	90~264 VAC or 120~370 VDC	3.3 VDC	900mA	2.97W	< 250mVp-p	69%	14000µF
PSAIC-5Sx		5 VDC	600mA	3W	< 200mVp-p	71%	8000µF
PSAIC-9Sx		9 VDC	333mA	3W	< 150mVp-p	76%	3200µF
PSAIC-12Sx		12 VDC	250mA	3W	< 100mVp-p	76%	1500µF
PSAIC-15Sx		15 VDC	200mA	3W	< 100mVp-p	76%	1000µF
PSAIC-24Sx		24 VDC	125mA	3W	< 100mVp-p	77%	470µF

#### NOTES

1. The "x" in the model number can be "A" for A type package or "B" for B type package. For more information on package types see page 3.

### CHARACTERISTICS

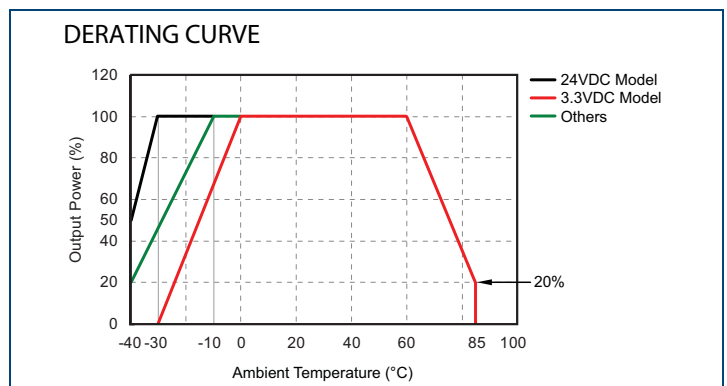
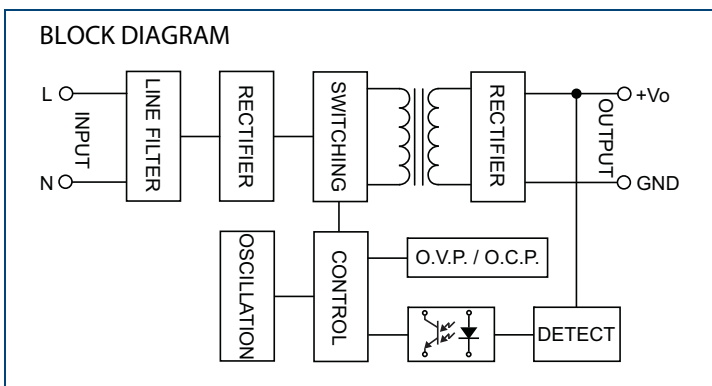

**SPECIFICATIONS: PSAIC SERIES**

All specifications are based on 25°C, Nominal Input Voltage, and Maximum Output Current unless otherwise noted.  
 We reserve the right to change specifications based on technological advances.

SPECIFICATION	TEST CONDITIONS		Min	Typ	Max	Unit
<b>INPUT SPECIFICATIONS</b>						
Input Voltage	AC input voltage range		90		264	VAC
	DC input voltage range		120		370	VDC
Input Frequency			47		63	Hz
Input Current	At 115VAC	Full load			75	mA
	At 230VAC				55	
Inrush Current	At 115VAC	< 500µs			20	A
	At 230VAC				50	
No Load Power Consumption					< 0.3	W
External Fuse (recommended)			3.15A slow blow type			
<b>OUTPUT SPECIFICATIONS</b>						
Output Voltage			See Table			
Voltage Accuracy				±10		%
Line Regulation	3.3VDC output model	LL to HL		±5		%
	5V ~ 24VDC output models			±2		
Load Regulation	3.3VDC output model	0% load to 100% load		±5		%
	5V ~ 24VDC output models			±2		
Output Power					3	W
Output Current			See Table			
Minimum Load			0			%
Ripple & Noise	Measured at 20MHz BW with 0.1µF and 47µF capacitors in parallel		See Table			
Max Capacitive Load			See Table			
Hold-Up Time			15			ms
Temperature Coefficient				±0.02		%/°C
<b>PROTECTION</b>						
Short Circuit Protection			Hiccup mode, indefinite (auto-recovery)			
Over Voltage Protection			Zener diode clamp			
Over Power Protection			Hiccup technique, auto-recovery			
<b>GENERAL SPECIFICATIONS</b>						
Efficiency			See Table			
Switching Frequency			124	132	140	KHz
Isolation Voltage (input to output)			3750			VAC
Leakage Current					0.25	mA
<b>ENVIRONMENTAL SPECIFICATIONS</b>						
Operating Temperature	With derating (see derating curve)		-40		+85	°C
Storage Temperature			-40		+85	°C
Humidity					95	%
Cooling			Free air convection			
MTBF	25°C (MIL-HDBK-217F)		> 650,000 hours			
<b>PHYSICAL SPECIFICATIONS</b>						
Weight			0.92oz (26g)			
Case Material			Plastic resin with Fiberglass (Flammability to UL 94V-0)			
Dimensions (L x W x H)			1.41 x 0.75 x 0.86 inches (35.7 x 19.0 x 22.0 mm)			
<b>SAFETY &amp; EMC</b>						
Safety Approvals	A type package	5V output model	UL, cUL, CE, CB			
		Others	UL, cUL, CE			
	B type package	All models	UL, cUL, CE			
EMC	EMI (Conducted and Radiated Emissions)		EN 55022 Class B			
	EMS (Noise Immunity)		EN 55024			

MECHANICAL DRAWINGS

A TYPE MODELS

Unit: inches (mm)

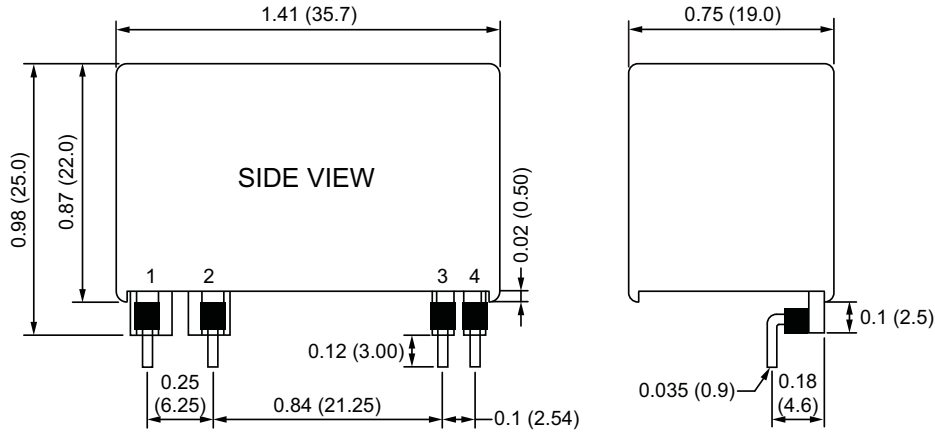

PIN CONNECTIONS	
Pin	Assignment
1	AC IN (L)
2	AC IN (N)
3	+DC OUT
4	-DC OUT

PCB = 0.04" (1.0mm)  
Tolerance: ±0.004" (±0.1mm)

B TYPE MODELS

Unit: inches (mm)

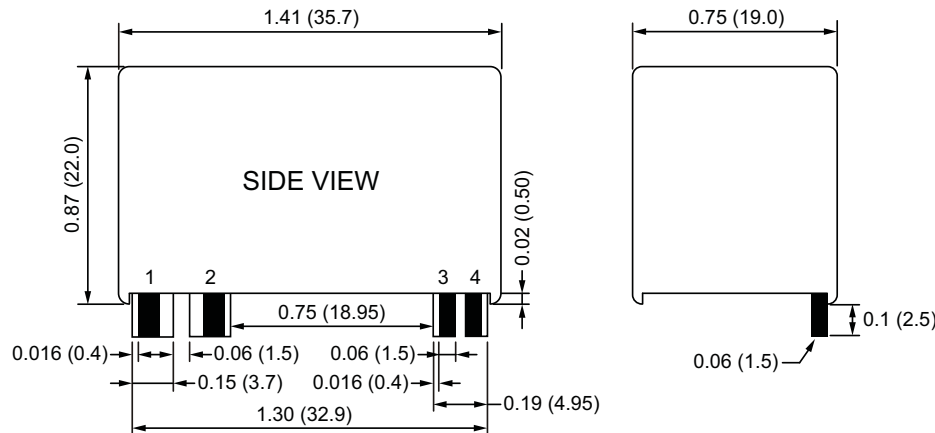

PIN CONNECTIONS	
Pin	Assignment
1	AC IN (L)
2	AC IN (N)
3	+DC OUT
4	-DC OUT

PCB = 0.04" (1.0mm)  
Tolerance: ±0.004" (±0.1mm)

PCB Footprint - Bottom Side View

Unit: inches (mm)

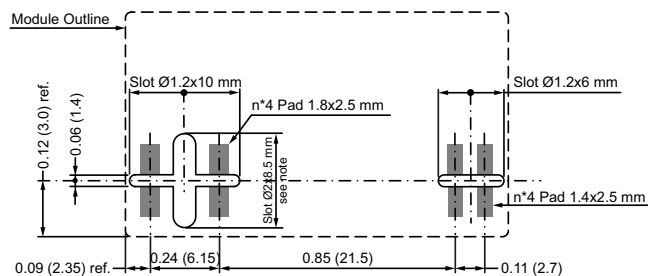

**NOTE**

The 2x8.5mm slot is not mandatory.  
This slot is useful when high creepage between PCB tracks is required.

## COMPANY INFORMATION

---

Wall Industries, Inc. has created custom and modified units for over 50 years. Our in-house research and development engineers will provide a solution that exceeds your performance requirements on-time and on budget. Our ISO9001-2008 certification is just one example of our commitment to producing a high quality, well-documented product for our customers.

Our past projects demonstrate our commitment to you, our customer. Wall Industries, Inc. has a reputation for working closely with its customers to ensure each solution meets or exceeds form, fit and function requirements. We will continue to provide ongoing support for your project above and beyond the design and production phases. Give us a call today to discuss your future projects.

Contact **Wall Industries** for further information:

Phone: ☎ (603)778-2300  
Toll Free: ☎ (888)597-9255  
Fax: ☎ (603)778-9797  
E-mail: [sales@wallindustries.com](mailto:sales@wallindustries.com)  
Web: [www.wallindustries.com](http://www.wallindustries.com)  
Address: 5 Watson Brook Rd.  
Exeter, NH 03833