

Product Specification

40BASE-SR4 QSFP+ Gen2 E-Temp Optical Transceiver Module

FTL410QE2N

PRODUCT FEATURES

- Four-channel full-duplex transceiver module
- Hot Pluggable QSFP+ form factor
- Maximum link length of 100m on OM3 Multimode Fiber (MMF) and 150m on OM4 MMF
- Multirate capability: 1.06Gb/s to 10.5Gb/s per channel
- Unretimed XLPP electrical interface
- Maximum power dissipation <1.5W
- Reliable VCSEL array technology
- Extended operating case temperature range: -5°C to 85°C
- Single 1x12 MPO receptacle
- RoHS-6 Compliant



APPLICATIONS

- 40GBASE-SR4 40G Ethernet
- Breakout to 10GBASE-SR Ethernet
- Proprietary interconnections

Finisar's FTL410QE2N QSFP+ transceiver modules are designed for use in 40 Gigabit per second links over multimode fiber. They are compliant with the QSFP+ MSA^{1,2} and IEEE 802.3ba 40GBASE-SR4³. Module-level digital diagnostic functions are available via an I2C interface, as specified by the QSFP+ MSA. The transceiver is RoHS compliant per Directive 2011/65/EU⁴ and Finisar Application Note AN-2038⁵.

PRODUCT SELECTION

FTL410QE2N

I. Pin Descriptions

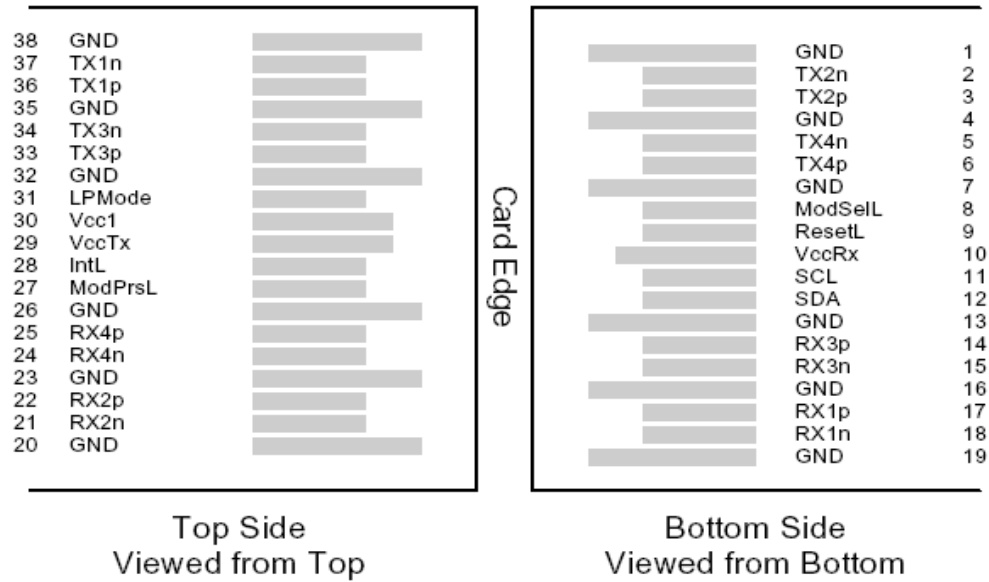

Figure 1 – QSFP+ MSA-compliant 38-pin connector

Pin	Symbol	Name/Description	Notes
1	GND	Ground	1
2	Tx2n	Transmitter Inverted Data Input	
3	Tx2p	Transmitter Non-Inverted Data Input	
4	GND	Ground	1
5	Tx4n	Transmitter Inverted Data Input	
6	Tx4p	Transmitter Non-Inverted Data Input	
7	GND	Ground	1
8	ModSelL	Module Select	
9	ResetL	Module Reset	
10	Vcc Rx	+3.3 V Power supply receiver	
11	SCL	2-wire serial interface clock	
12	SDA	2-wire serial interface data	
13	GND	Ground	1
14	Rx3p	Receiver Non-Inverted Data Output	
15	Rx3n	Receiver Inverted Data Output	
16	GND	Ground	1
17	Rx1p	Receiver Non-Inverted Data Output	
18	Rx1n	Receiver Inverted Data Output	
19	GND	Ground	1
20	GND	Ground	1
21	Rx2n	Receiver Inverted Data Output	
22	Rx2p	Receiver Non-Inverted Data Output	
23	GND	Ground	1
24	Rx4n	Receiver Inverted Data Output	
25	Rx4p	Receiver Non-Inverted Data Output	

26	GND	Ground	1
27	ModPrsL	Module Present	
28	IntL	Interrupt	
29	Vcc Tx	+3.3 V Power supply transmitter	
30	Vcc1	+3.3 V Power Supply	
31	LPMode	Low Power Mode	
32	GND	Ground	1
33	Tx3p	Transmitter Non-Inverted Data Input	
34	Tx3n	Transmitter Inverted Data Input	
35	GND	Ground	1
36	Tx1p	Transmitter Non-Inverted Data Input	
37	Tx1n	Transmitter Inverted Data Input	
38	GND	Ground	1

Notes

1. Circuit ground is internally isolated from chassis ground.

II. General Product Characteristics

Parameter	Value	Unit	Notes
Module Form Factor	QSFP+		
Number of Lanes	4 Tx and 4 Rx		
Maximum Aggregate Data Rate	42.0	Gb/s	
Maximum Data Rate per Lane	10.5	Gb/s	Higher bit rates may be supported. Please contact Finisar.
Protocols Supported	Typical applications include 40G Ethernet, Infiniband, Fibre Channel, SATA/SAS3		
Operating Case Temperature	-5 to +85	C	
Electrical Interface and Pin-out	38-pin edge connector		Pin-out as defined by the QSFP+ MSA
Maximum Power Consumption per End	1.5	Watts	Varies with output voltage swing and pre-emphasis settings (see Figure 2)
Management Interface	Serial, I2C-based, 400 kHz maximum frequency		As defined by the QSFP+ MSA

Data Rate Specifications	Symbol	Min	Typ	Max	Units	Ref.
Bit Rate per Lane	BR	1062		10500	Mb/sec	1
Bit Error Ratio	BER			10^{-12}		2
Link distance on OM3 MMF	d			100	meters	3
Link distance on OM4 MMF	d			150	meters	3

Notes:

1. Compliant with 40G Ethernet. Compatible with 1/10 Gigabit Ethernet and 1/2/4/8/10G Fibre Channel.
2. Tested with a PRBS $2^{31}-1$ test pattern.
3. Per 40GBASE-SR4, IEEE 802.3ba

III. Absolute Maximum Ratings

Parameter	Symbol	Min	Typ	Max	Unit	Ref.
Maximum Supply Voltage	V _{cc1} , V _{ccTx} , V _{ccRx}	-0.5		3.6	V	
Storage Temperature	T _S	-40		85	°C	
Case Operating Temperature	T _{OP}	-5		85	°C	
Relative Humidity	RH	0		85	%	1
Damage Threshold, per Lane	DT	3.4			dBm	

Notes:

1. Non-condensing.

IV. Electrical Characteristics (T_{OP} = -5 to 85°C, V_{CC} = 3.15 to 3.45 Volts)

Parameter	Symbol	Min	Typ	Max	Unit	Ref.
Supply Voltage	V _{cc1} , V _{ccTx} , V _{ccRx}	3.15		3.45	V	
Supply Current	I _{cc}			350	mA	
Link turn-on time						
Transmit turn-on time				2000	ms	2
Transmitter (per Lane)						
Single ended input voltage tolerance	V _{inT}	-0.3		4.0	V	
Differential data input swing	V _{in,pp}	180		1200	mV _{pp}	3
Differential input threshold			50		mV	
AC common mode input voltage tolerance (RMS)		15			mV	
Differential input return loss				Per IEEE P802.3ba, Section 86A.4.1.1	dB	4
J2 Jitter Tolerance	J _{t2}	0.17			UI	
J9 Jitter Tolerance	J _{t9}	0.29			UI	
Data Dependent Pulse Width Shrinkage	DDPWS	0.07			UI	
Eye mask coordinates {X1, X2 Y1, Y2}			0.11, 0.31 95, 350		UI mV	5
Receiver (per Lane)						
Single-ended output voltage		-0.3		4.0	V	
Differential data output swing	V _{out,pp}	0		800	mV _{pp}	7,8
AC common mode output voltage (RMS)				7.5	mV	
Termination mismatch at 1 MHz				5	%	
Differential output return loss				Per IEEE P802.3ba, Section 86A.4.2.1	dB	4
Common mode output return loss				Per IEEE P802.3ba, Section 86A.4.2.2	dB	4
Output transition time, 20% to 80%		28			ps	
J2 Jitter output	J _{o2}			0.42	UI	
J9 Jitter output	J _{o9}			0.65	UI	
Eye mask coordinates #1 {X1, X2 Y1, Y2}			0.29, 0.5 150, 425		UI mV	6
Eye mask coordinates #2 {X1, X2 Y1, Y2}			0.29, 0.5 125, 500		UI mV	5
Power Supply Ripple Tolerance	PSR	50			mV _{pp}	

Notes:

1. Maximum total power value is specified across the full temperature and voltage range.
2. From power-on and end of any fault conditions.
3. After internal AC coupling. Self-biasing 100Ω differential input.
4. 10 MHz to 11.1 GHz range
5. Hit ratio = $5 \times 10E-5$. Valid for all settings in Figure 2.
6. Hit ratio = $5 \times 10E-5$. Valid only for the shaded settings in Figure 2.
7. AC coupled with 100Ω differential output impedance.
8. Settable in 4 discrete steps via the I2C interface. See Figure 2 for Vout settings.

Power (mW)	Pre-Emphasis into 100ohms (mV)			
	0	125	175	325
Vout (mV)	0	599		
	317	751	935	971
	422	787	971	1007
	739	883	1055	1103
				1075
				1111
				1190

Figure 2 – Power Dissipation (mW, maximum) vs. Rx Output Conditions

V. Optical Characteristics ($T_{OP} = -5$ to $85^{\circ}C$, $V_{CC} = 3.15$ to 3.45 Volts)

Parameter	Symbol	Min	Typ	Max	Unit	Ref.
Transmitter (per Lane)						
Signaling Speed per Lane			10.5		GBd	1
Center wavelength		840		860	nm	
RMS Spectral Width	SW			0.65	nm	
Average Launch Power per Lane	TXP _x	-7.6		0.0	dBm	
Transmit OMA per Lane	TxOMA	-5.6		3.0	dBm	2
Difference in Power between any two lanes [OMA]	DP _x			4.0	dB	
Peak Power per Lane	PP _x			4.0	dBm	
Launch Power [OMA] minus TDP per Lane	P-TDP	-6.5			dBm	
TDP per Lane	TDP			3.5	dBm	
Optical Extinction Ratio	ER	3.0			dB	
Optical Return Loss Tolerance	ORL			12	dB	
Encircled Flux	FLX	> 86% at 19 um < 30% at 4.5 um			dBm	
Average launch power of OFF transmitter, per lane				-30	dBm	
Relative Intensity Noise	RIN			-128	dB/Hz	
Transmitter eye mask definition {X1, X2, X3, Y1, Y2, Y3}		0.23, 0.34, 0.43, 0.27, 0.35, 0.4				

Parameter	Symbol	Min	Typ	Max	Unit	Ref.
Receiver (per Lane)						
Signaling Speed per Lane			10.5		GBd	3
Center wavelength		840		860	nm	
Damage Threshold	DT	3.4			dBm	
Average Receive Power per Lane	RXP _x	-9.5		2.4	dBm	
Receive Power (OMA) per Lane	RxOMA			3.0	dBm	
Stressed Receiver Sensitivity (OMA) per Lane	SRS			-5.4	dBm	
Peak Power, per lane	PP _x			4	dBm	
Receiver Reflectance	Rfl			-12	dB	
Vertical eye closure penalty, per lane				1.9	dB	
Stressed eye J2 jitter, per Lane				0.3	UI	
Stressed eye J9 jitter, per Lane				0.47	UI	
OMA of each aggressor lane				-0.4	dBm	
Rx jitter tolerance: Jitter frequency and p-p amplitude		(75, 5)			kHz, UI	
		(375, 1)			kHz, UI	
LOS De-Assert	LOS _D			-12	dBm	
LOS Assert	LOS _A	-30			dBm	
LOS Hysteresis		0.5			dBm	

Notes:

1. Transmitter consists of 4 lasers operating at a maximum rate of 10.5Gb/s each.
2. Even if TDP is <0.9dB, the OMA min must exceed this value.
3. Receiver consists of 4 photodetectors operating at a maximum rate of 10.5Gb/s each.

VI. Memory Map and Control Registers

Compatible with SFF-8436¹ and SFF-8636.² Please see Finisar Application Note AN-2079⁶ for implementation details.

VII. Environmental Specifications

Finisar FTL410QE2N transceivers have an operating temperature range from -5°C to +85°C case temperature.

Environmental Specifications	Symbol	Min	Typ	Max	Units	Ref.
Case Operating Temperature	T _{op}	-5		85	°C	
Storage Temperature	T _{sto}	-40		85	°C	

VIII. Regulatory Compliance

Finisar FTL410QE2N transceivers are RoHS-6 Compliant. Copies of certificates are available at Finisar Corporation upon request.

FTL410QE2N transceiver modules are Class 1 laser eye safety compliant per IEC 60825-1.

IX. Mechanical Specifications

The FTL410QE2N mechanical specifications are compliant to the QSFP+ MSA transceiver module specifications.

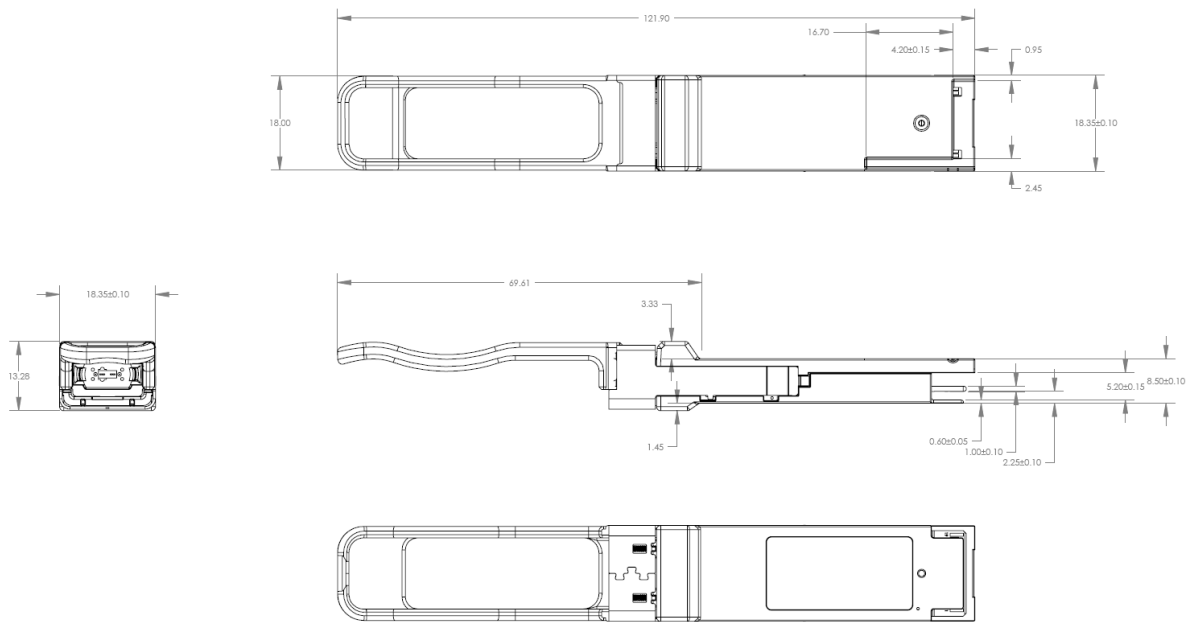

Figure 3 – FTL410QE2N mechanical drawing



Figure 4 – FTL410QE2N product label

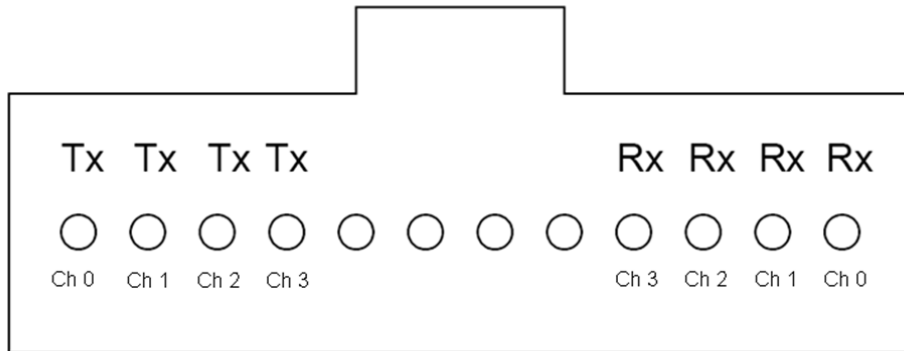

Figure 5 – FTL410QE2N optical lane assignment
(front view of MPO receptacle)

X. References

1. SFF-8436 – Specification for QSFP+ Copper and Optical Transceiver, Rev 4.8, October 2013.
2. SFF-8636 – Specification for Common Management Interface, Rev 1.7, January 2014.
3. IEEE 802.3ba – PMD Type 40GBASE-SR4.
4. Directive 2011/65/EU of the European Council Parliament and of the Council, “on the restriction of the use of certain hazardous substances in electrical and electronic equipment,” June 8, 2011, which supercedes the previous RoHS Directive 2002/95/EC.
5. “Application Note AN-2038: Finisar Implementation of RoHS Compliant Transceivers”, Finisar Corporation, January 21, 2005.
6. “Application Note AN-2079: QSFP Module EEPROM Mapping”, Rev. G, Finisar Corporation, May, 2013.

XI. For More Information

Finisar Corporation
1389 Moffett Park Drive
Sunnyvale, CA 94089-1133
Tel. 1-408-548-1000
Fax 1-408-541-6138
sales@finisar.com
www.finisar.com