

TO252-3L, JEDEC OPTION AA, PACKING CONFIGURATION: Figure 1.0

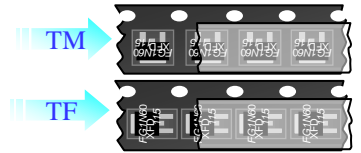

TO252-3L Unit Orientation

Packing Description:

TO252-3L parts are shipped in tape. The carrier tape is made from a dissipative (carbon filled) polycarbonate resin. The cover tape is a multilayer film (Heat Activated Adhesive in nature) primarily composed of polyester film, adhesive layer, sealant, and anti-static sprayed agent. These reeled parts in standard option are shipped with 2500(TM) / 2000(TF) units per 13" or 330cm diameter reel. The reels are dark blue or black in color and is made of polystyrene plastic (anti-static coated). This and some other options are further described in the Packing Information table.

These full reels are individually barcode labeled and placed inside a standard intermediate box (illustrated in figure 1.0) made of recyclable corrugated brown paper. One box contains three reels maximum. And these boxes are placed inside a barcode labeled shipping box which comes in different sizes depending on the number of parts shipped.

TO252-3L Packing Information				
Packing Option	Standard (TF)		Standard (TM)	
	Single Reel	Double Reel	Single Reel	Double Reel
Packing type	TNR	TNR	TNR	TNR
Qty per Reel/Tube/Bag	2,000	2,000	2,500	2,500
Reel Size	13" Dia	13" Dia	13" Dia	13" Dia
Inner Box Dimension (mm)	333x333x25	343x350x68	333x333x25	343x350x68
Max qty per Box	2,000	4,000	2,500	5,000
Outer Box Dimension (mm)	360x360x300	360x360x300	360x360x300	360x360x300
Max qty per Box	24,000	24,000	30,000	30,000

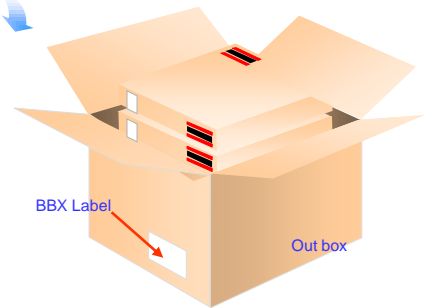
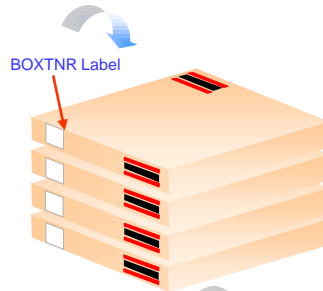

Reel Barcode Label Sample

LOT: [Barcode] **QTY:** [Barcode]
FSID: [Barcode] **SPEC:** 2ND Level Interconnect
D/C1: **QTY1:** **SPEC REV:** 6-Free 1. Category e3
D/C2: **QTY2:** **RoHS COMPLIANT** 2. Maximum safe temperature 200 deg C
FAIRCHILD SEMICONDUCTOR (BOXTNR) 6.1

Inner Box Barcode Label Sample

LOT: [Barcode] **QTY:** [Barcode]
FSID: [Barcode] **SPEC:** 2ND Level Interconnect
D/C1: **QTY1:** **SPEC REV:** 6-Free 1. Category e3
D/C2: **QTY2:** **RoHS COMPLIANT** 2. Maximum safe temperature 200 deg C
FAIRCHILD SEMICONDUCTOR (BOXTNR) 6.1

Outer Box Barcode Label Sample

PART ID: [Barcode] **LOT:** [Barcode] **QTY:** [Barcode]
FAIRCHILD SEMICONDUCTOR CORPORATION 2013/02/01 08:33:54
SM13B11526 **RoHS COMPLIANT** BG FS00130
(BBX) 1.2

TO252-3L, JEDEC OPTION AA Tape Leader and Trailer Configuration: Figure 2.0

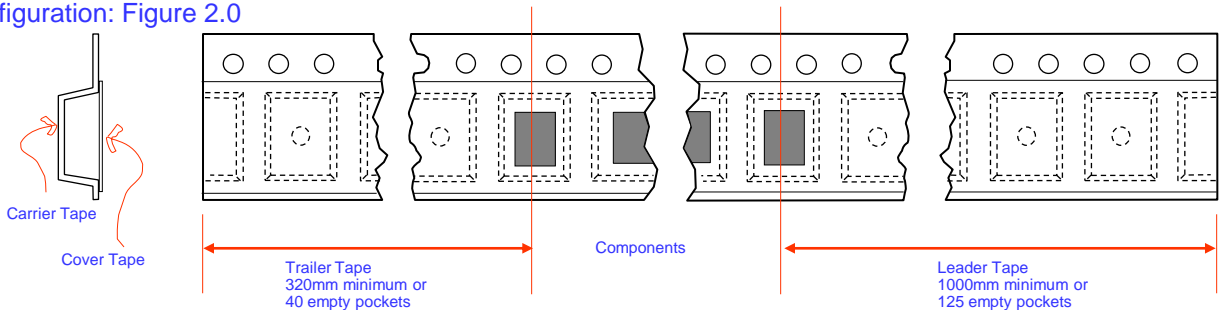

NOTES:

- A. ALL DIMENSION ARE IN MILLIMETERS UNLESS OTHERWISE SPECIFIED
- B. DRAWING FILE NAME: PKG-TO252A03REV2
- C. PLASTIC REEL W1 DIMENSION CONTROL LIMITS:
8MM REEL = +/-1.0MM AND 12MM REEL AND ABOVE = +/- 1.5MM

TO252-3L, JEDEC OPTION AA, Embossed Carrier Tape
Configuration: Figure 3.0

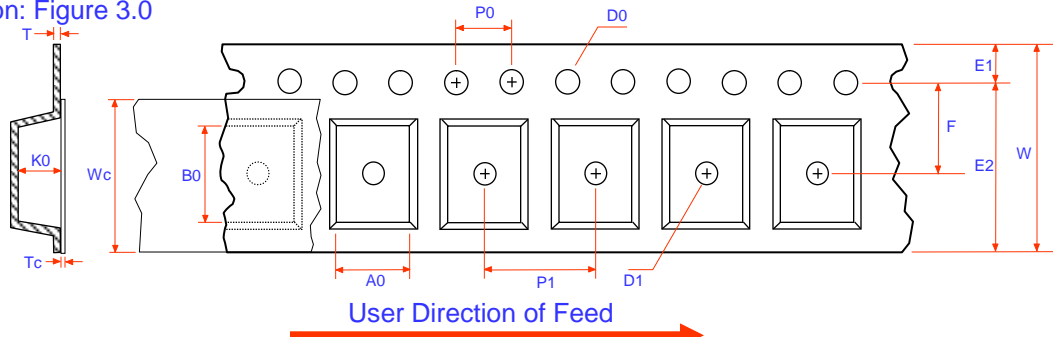

Dimensions are in millimeter

Pkg type	A0	B0	W	D0	D1	E1	E2	F	P1	P0	K0	T	Wc	Tc
TO252-3L TM / XM (16mm)	7.10 +/-0.10	10.50 +/-0.10	16.0 +/-0.3	1.50 0.10 /-0.00	1.7 +/-0.10	1.75 +/-0.10	14.25 min	7.50 +/-0.10	8.0 +/-0.1	4.0 +/-0.1	2.65 +/-0.10	0.30 +/-0.05	13.3 +/-0.1	0.1 max
TO252-3L TF / X (16mm)	10.80 +/-0.10	7.20 +/-0.10	16.0 +/-0.3	1.5 0.1 /-0.00	1.7 +/-0.10	1.75 +/-0.10	14.25 min	7.50 +/-0.10	12.0 +/-0.1	4.0 +/-0.1	2.70 +/-0.10	0.30 +/-0.05	13.3 +/-0.1	0.1 max

Notes: A0, B0, and K0 dimensions are determined with respect to the EIA/Jedec RS-481 rotational and lateral movement requirements (see sketches A, B, and C).

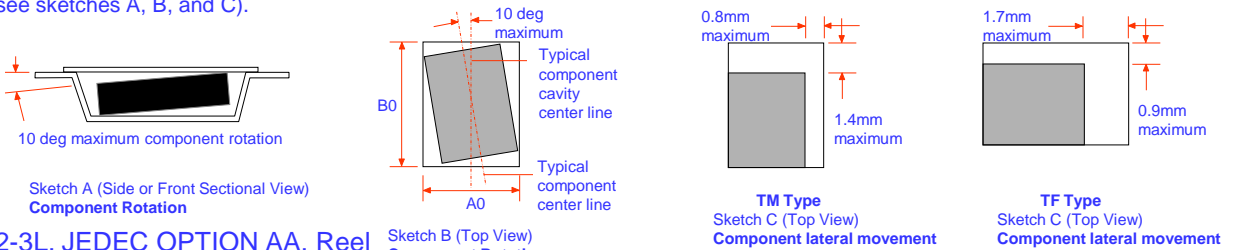

TO252-3L, JEDEC OPTION AA, Reel
Configuration: Figure 4.0

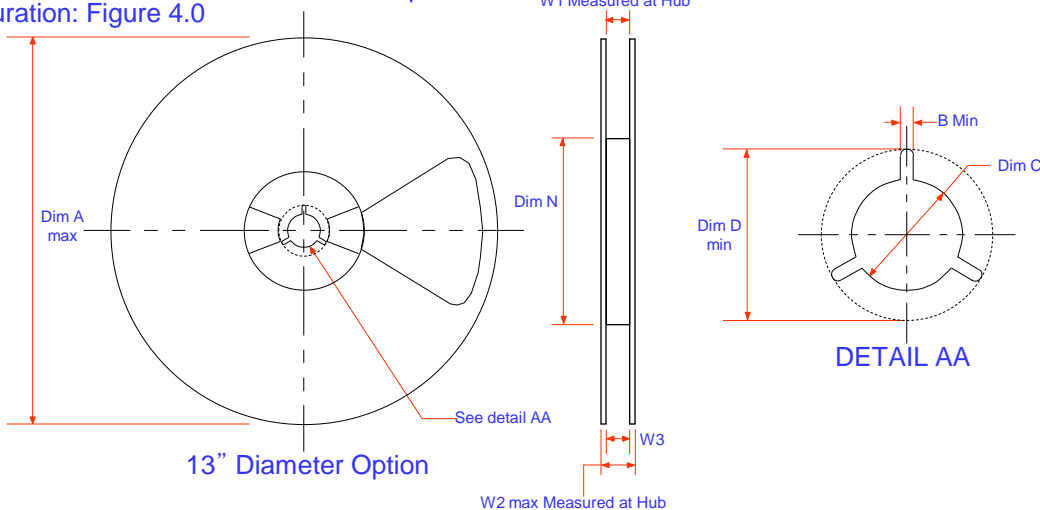

Dimensions are in inches and millimeters

Tape Size	Reel Option	Dim A	Dim B	Dim C	Dim D	Dim N	Dim W1	Dim W2	Dim W3 (LSL-USL)
16mm	13" Dia	330	1.5	13 +0.5/-0.2	20.2	100	16.4 +2/0	22.4	15.9 - 19.4

NOTES:

- A. ALL DIMENSION ARE IN MILLIMETERS UNLESS OTHERWISE SPECIFIED
- B. DRAWING FILE NAME: PKG-TO252A03REV2
- C. PLASTIC REEL W1 DIMENSION CONTROL LIMITS:
 8MM REEL = +/-1.0MM AND 12MM REEL AND ABOVE = +/- 1.5MM