

Quad 12MHz, 145ns Settling Precision Current-to-Voltage Converter for Optical Disk Drives

FEATURES

- Four Complete Current-to-Voltage Converters
- 14-Lead Small Outline Package
- Accurate Gain: 20mV/μA, ±4%
- Low Offset Error: 250nA Max
- Low Offset Drift: 2.5nA/°C Max
- Fast Settling: 145ns to 0.1% for a 2V Step
- Wide Bandwidth: 12MHz
- Low Noise: 5pA/√Hz
- Low Quiescent Current: 11mA Max
- Wide Supply Range: ±2V to ±18V or 4V to 36V

APPLICATIONS

- Optical Disk Drive
 - Photo Diode Amplifiers
 - Focus and Tracking Summing Amplifiers
- Color Scanners
 - RGB Amplifiers
 - Selectable Gain Amplifiers
- Matched Inverting Amplifiers

DESCRIPTION

The LT[®]1311 is a quad current-to-voltage converter designed for the demanding requirements of photo diode amplification. A new approach to current-to-voltage conversion provides excellent DC and AC performance without external DC trims or AC frequency compensation. The LT1311 is ideal for converting multiple photo diode currents to voltages and for general purpose matched inverting amplifier applications.

The LT1311 contains four current feedback amplifiers, each with an internal 20k feedback resistor. A supply bypass capacitor is the only external component required to convert four signal currents to voltages. Unlike voltage feedback-based current-to-voltage converters that operate with only a specified value of input capacitance, the current feedback LT1311 settles cleanly with any input capacitance up to 50pF. Only in the most demanding applications will the LT1311 need to be mounted close to the photo diodes.

LT, LTC and LT are registered trademarks of Linear Technology Corporation.

TYPICAL APPLICATION

Photo Diode Current-to-Voltage Converter

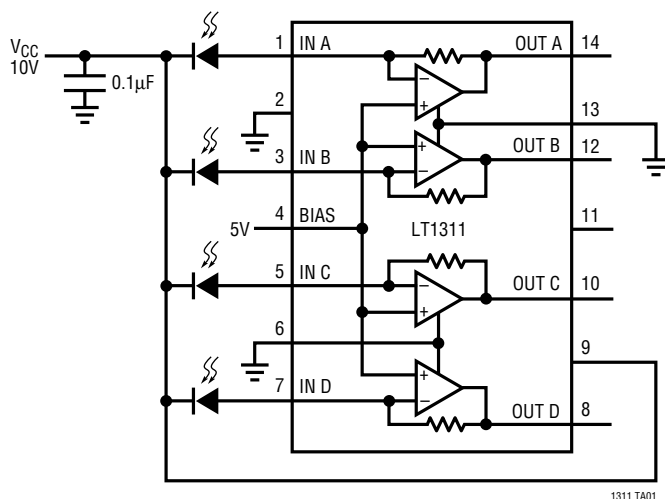

Transient Response

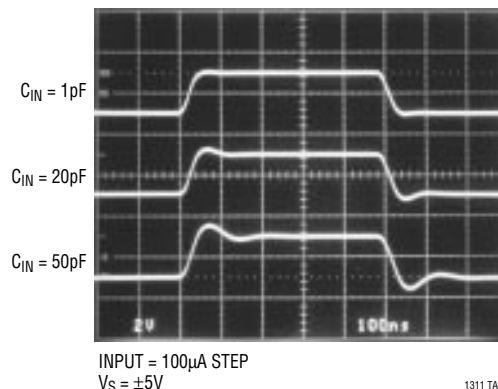

ABSOLUTE MAXIMUM RATINGS

Total Supply Voltage (V^+ to V^-)	36V
Input Current	$\pm 15\text{mA}$
Output Short-Circuit Duration (Note 1)	Continuous
Operating Temperature Range	-40°C to 85°C
Specified Temperature Range	0°C to 70°C
Junction Temperature	150°C
Storage Temperature Range	-65°C to 150°C
Lead Temperature (Soldering, 10 sec)	300°C

PACKAGE/ORDER INFORMATION

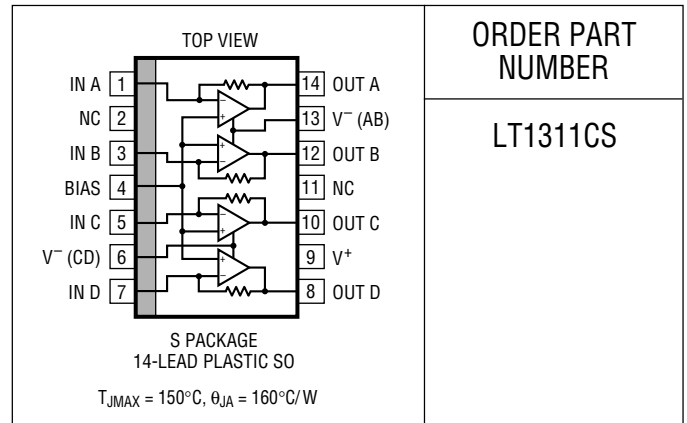

ORDER PART NUMBER

LT1311CS

Consult factory for Industrial and Military grade parts.

ELECTRICAL CHARACTERISTICS $V_S = 10\text{V}$, $V_{BIAS} = 5\text{V}$, $T_A = 25^\circ\text{C}$, unless otherwise noted.

SYMBOL	PARAMETER	CONDITIONS	MIN	TYP	MAX	UNITS	
	Current to Voltage Gain	$V_{OUT} = 2\text{V}$ to 8V , $R_L = 2\text{k}$ to 5V	●	19.2	20	20.8	$\text{mV}/\mu\text{A}$
	Current to Voltage Gain Drift		●	-70		$\text{ppm}/^\circ\text{C}$	
	Current to Voltage Gain Mismatch	Between Amplifiers $(\Delta G/20\text{k}) \times 100\%$	●	0.1	1.0	%	
V_{OS}	Input Offset Voltage	With Respect to V_{BIAS}	●	± 150	± 500	μV	
$\Delta V_{OS}/\Delta T$	Input Offset Voltage Drift			± 1		$\mu\text{V}/^\circ\text{C}$	
	Output Offset Voltage	With Respect to V_{BIAS} $V_S = \pm 15\text{V}$, $V_{BIAS} = 0\text{V}$	●	± 1.5	± 5	mV	
	Output Offset Voltage Drift	$(A + B) - (C + D)$	●	± 10	± 50	$\mu\text{V}/^\circ\text{C}$	
	Output Offset Voltage Mismatch	Between Amplifiers	●	± 2	± 4	mV	
	Bias Input Current	Pin 4	●	± 5	± 20	μA	
	Output Noise Voltage Density	$f = 1\text{kHz}$		100		$\text{nV}/\sqrt{\text{Hz}}$	
i_n	Input Noise Current Density	$f = 1\text{kHz}$		5		$\text{pA}/\sqrt{\text{Hz}}$	
e_n	Input Noise Voltage Density	$f = 1\text{kHz}$, $A_V = 40\text{dB}$		4.5		$\text{nV}/\sqrt{\text{Hz}}$	
	Input Impedance	$\Delta V_{OS}/\Delta I_{IN}$, DC, $\Delta V_{OUT} = 2\text{V}$ to 8V ($I_{IN} = \pm 150\mu\text{A}$) $\Delta V_{OS}/\Delta I_{IN}$, $f = 10\text{MHz}$	●	0.2	2	Ω	
	Bias Voltage Range		●	$V^- + 2\text{V}$	$V^+ - 2\text{V}$	V	
	Bias Rejection Ratio	$\Delta V_{OUT}/\Delta V_{BIAS}$, $V_{BIAS} = 2\text{V}$ to 8V	●	55	64	dB	
	Bias Input Resistance	$V_{BIAS} = 2\text{V}$ to 8V	●	250	500	$\text{k}\Omega$	
	Bias Input Capacitance	$f = 100\text{kHz}$		18		pF	
PSRR	Power Supply Rejection Ratio	$V_S = \pm 2\text{V}$ to $\pm 15\text{V}$, $V_{BIAS} = 0\text{V}$	●	90	103	dB	
	Minimum Supply Voltage	$V_{BIAS} = 2\text{V}$	●	4		V	
	Voltage Gain	$\Delta V_{OUT}/\Delta V_{OS}$, $V_{OUT} = 2\text{V}$ to 8V , $R_L = 2\text{k}$ to 5V	●	10	100	V/mV	
V_{OUT}	Maximum Output Voltage Swing	Output High, No Load, $I_{IN} = -250\mu\text{A}$ Output High, $I_{SOURCE} = 10\text{mA}$, $I_{IN} = -250\mu\text{A}$ Output Low, No Load, $I_{IN} = 250\mu\text{A}$ Output Low, $I_{SINK} = 10\text{mA}$, $I_{IN} = 250\mu\text{A}$	●	8.8	9.0	V	
	Output Impedance	$I_{OUT} = 0\text{mA}$, $f = 10\text{MHz}$		60		Ω	
I_{OUT}	Maximum Output Current	$I_{IN} = \pm 200\mu\text{A}$, $V_{OUT} = 5\text{V}$	●	± 30	± 55	mA	
I_S	Supply Current	$I_{IN} = 0$	●	7	11	mA	
SR	Slew Rate	$I_{IN} = \pm 150\mu\text{A}$, V_{OUT} at 3V , 7V		80		$\text{V}/\mu\text{s}$	

ELECTRICAL CHARACTERISTICS $V_S = 10V, V_{BIAS} = 5V, T_A = 25^\circ C$, unless otherwise noted.

SYMBOL	PARAMETER	CONDITIONS	MIN	TYP	MAX	UNITS
BW	Small-Signal Bandwidth			12		MHz
	Full Power Bandwidth	$V_{OUT} = 2.5V_{P-P}, R_{IN} = 20k$		10		MHz
t_r, t_f	Rise Time, Fall Time	10% to 90%, $V_{OUT} = 6V_{P-P}, R_{IN} = 20k$		65		ns
		10% to 90%, $V_{OUT} = 100mV_{P-P}, R_{IN} = 20k$		35		ns
OS	Overshoot	$V_{OUT} = 100mV_{P-P}, R_{IN} = 20k$		0		%
t_s	Settling Time	$\Delta V_{OUT} = 2V, 0.1\%, R_{IN} = 20k$		145		ns
		$V_S = \pm 15V, \Delta V_{OUT} = 10V, 0.1\%, R_{IN} = 20k$		210		ns
THD	Total Harmonic Distortion	$V_{OUT} = 2V_{RMS}, 20Hz$ to $20kHz, R_{IN} = 20k$		0.004		%
	Crosstalk	$V_{OUT} = 3V$ to $7V, R_L = 2k$ to $5V, f = 100Hz,$ 3 Channels Driven		110		dB

The ● denotes specifications which apply over the full specified temperature range of 0°C to 70°C.

Note 1: A heat sink may be required depending on the power supply voltage and the number of amplifiers that are shorted.

TYPICAL PERFORMANCE CHARACTERISTICS

Supply Current vs Supply Voltage

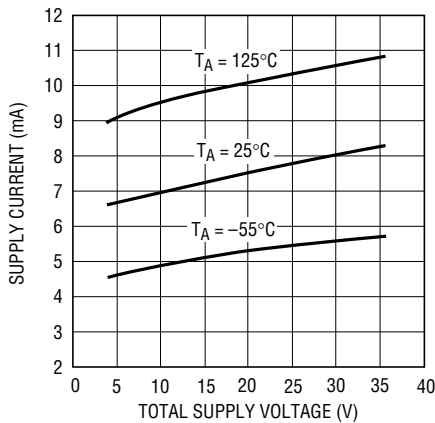

1311 G01

Bias Voltage Range vs Temperature

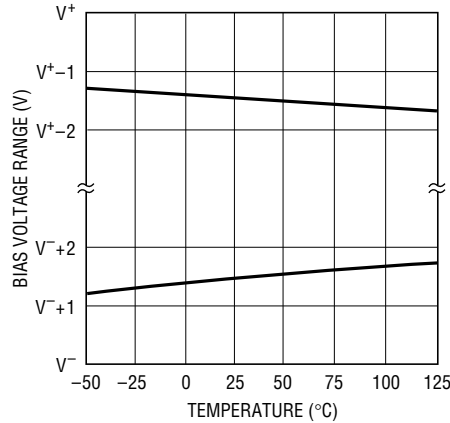

1311 G02

Output Saturation Voltage vs Load Current

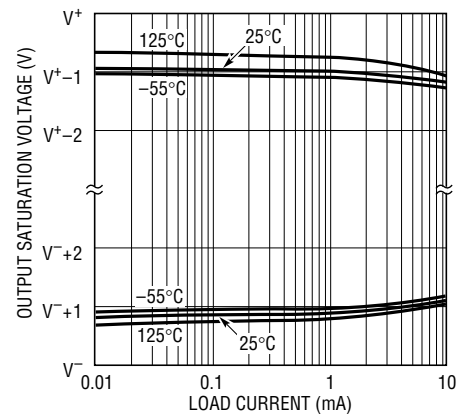

1311 G03

Short-Circuit Current vs Temperature

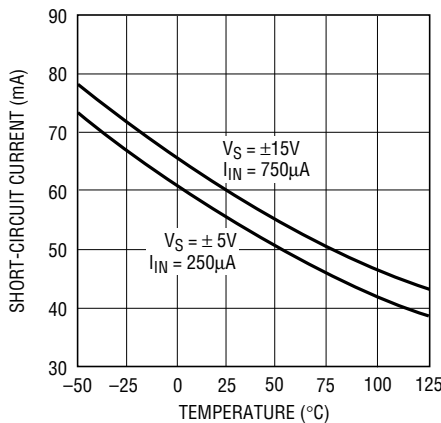

1311 G04

-3dB Bandwidth vs Load Resistance

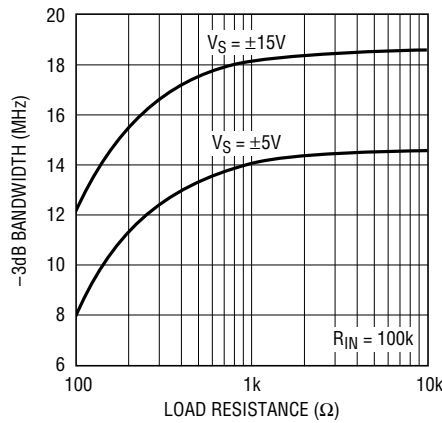

1131 G05

Output Impedance vs Frequency

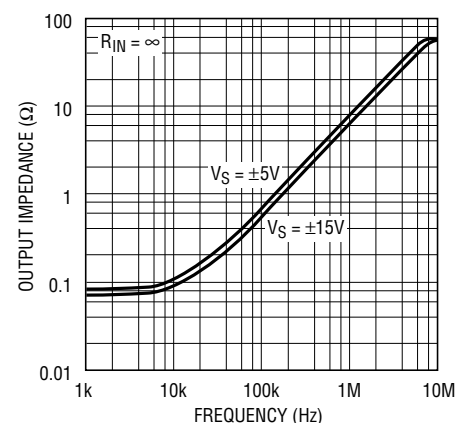

1311 G06

TYPICAL PERFORMANCE CHARACTERISTICS

Settling Time to 0.1%, 1mV, 10mV vs Output Step

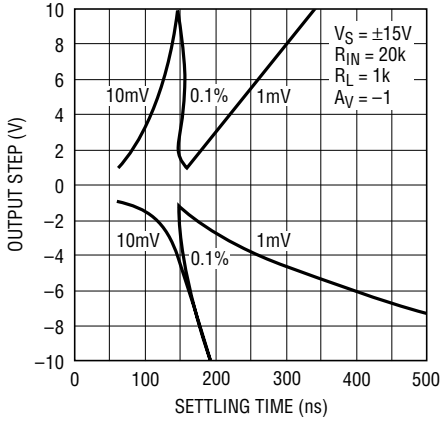

1311 G07

0.1% Settling Time vs Input Capacitance

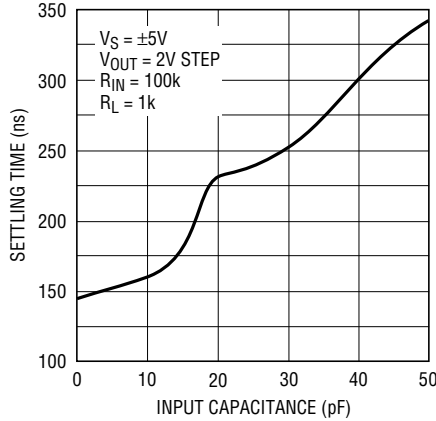

1311 G08

0.1% Settling Time vs Capacitive Load

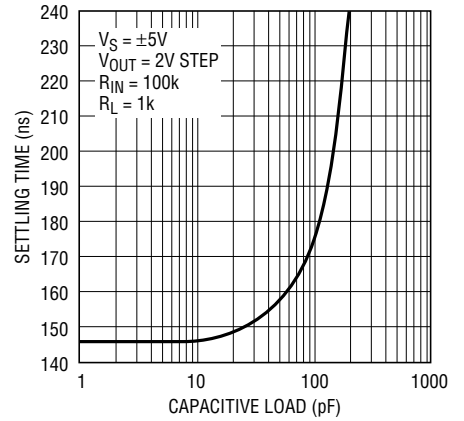

1311 G09

Gain and Phase vs Frequency

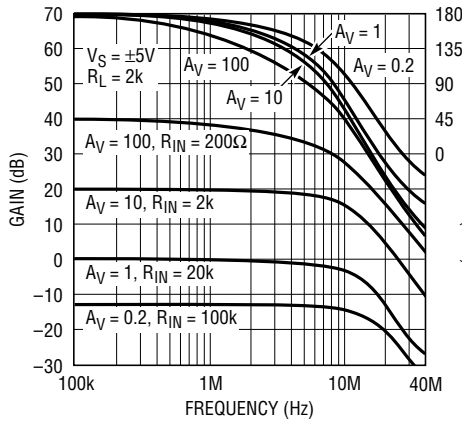

1311 G10

Frequency Response for Various Input Capacitance

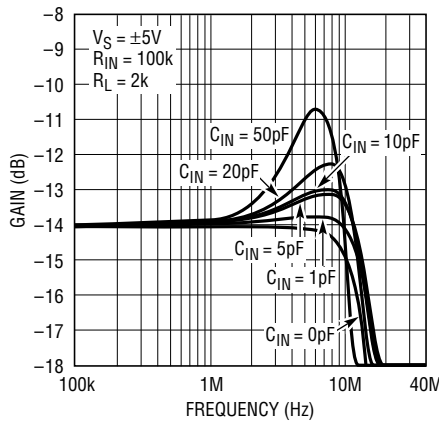

1311 G11

Frequency Response for Various Capacitive Loads

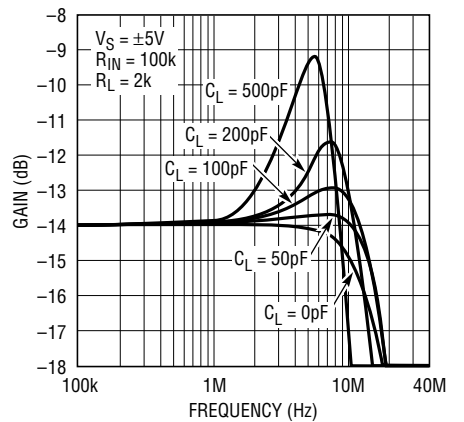

1311 G12

Power Supply Rejection Ratio vs Frequency

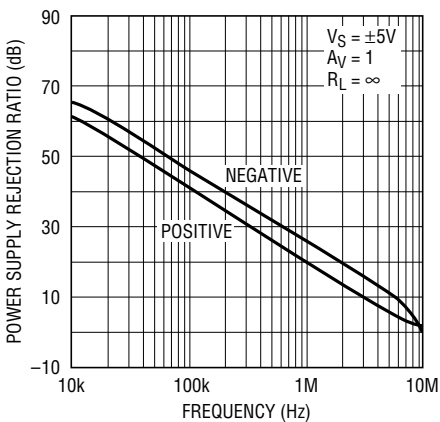

1311 G13

Total Harmonic Distortion vs Frequency

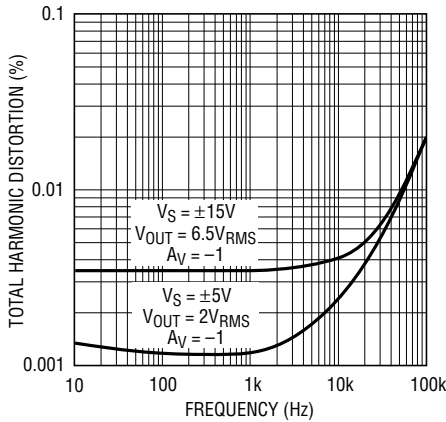

1311 G14

Noise Spectrum

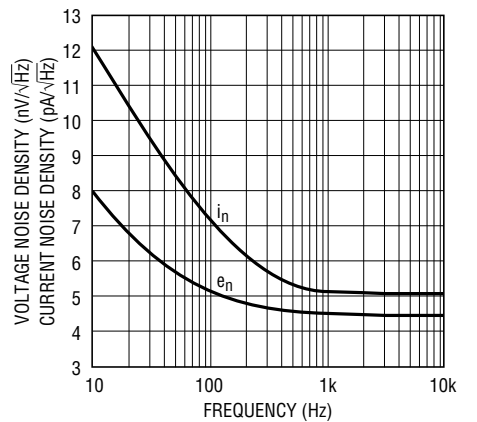

1311 G15

TYPICAL PERFORMANCE CHARACTERISTICS

Small-Signal Response

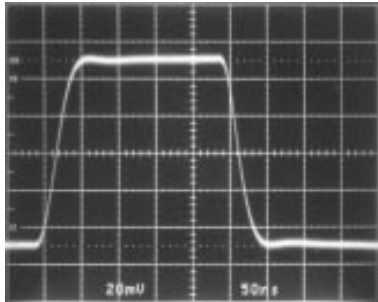

$V_S = \pm 5V$
 $A_V = -1$
 $R_L = 2k$

1311 G16

Large-Signal Response

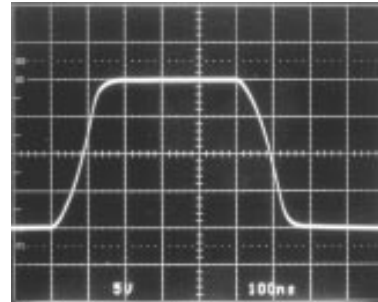

$V_S = \pm 15V$
 $A_V = -1$
 $R_L = 2k$

1311 G17

SIMPLIFIED SCHEMATIC

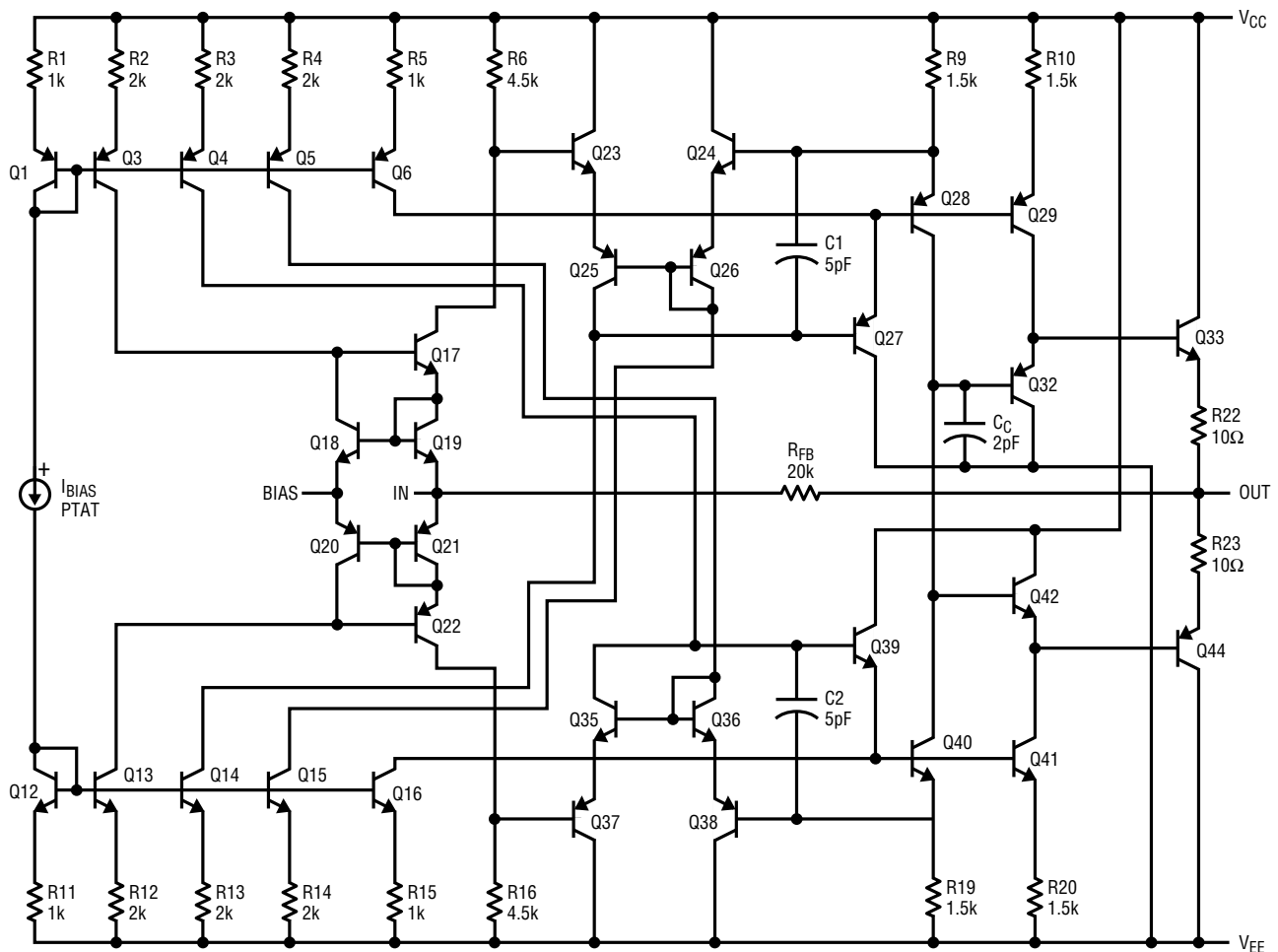

1311 SS

APPLICATIONS INFORMATION

Description

The LT1311 contains four identical current feedback amplifiers with their noninverting inputs tied together at pin 4. An external bias voltage is applied to this pin to set the quiescent output voltage of each amplifier. Each amplifier has an internal 20k feedback resistor between the output and the inverting input. The amplifiers are packaged in a 14-pin SO package with all four inverting inputs on one side and the outputs on the other. None of the inputs (or the outputs) are on adjacent pins for excellent channel separation.

The feedback resistors in the LT1311 are laser-trimmed at wafer sort to set the current-to-voltage gain. The gain is set to 20mV/ μ A; the change with temperature is typically -70 ppm/ $^{\circ}$ C. The gain matching of the four amplifiers is ten times better. The input offset voltage and bias current are trimmed as well. The trimming also minimizes the resulting output offset drift. For more detailed circuit information, please see the May 1995 (Volume 5, Number 2) issue of *Linear Technology* magazine.

Supply Voltages

The LT1311 can be operated on single or split supplies. The total supply voltage must be greater than 4V and less than 36V. The bias voltage applied to pin 4 can be any value from 2V above the negative supply to 2V below the positive supply. The outputs can swing to within 1V of either supply.

The LT1311 is trimmed while operating on a single 10V supply with a bias voltage of 5V; this is the equivalent of ± 5 V supplies with the bias at ground. Operation on a single 5V supply with a bias voltage of 2.5V results in very similar performance. Operation on ± 15 V supplies results in slightly more bandwidth and offset (see the electrical tables and the characteristic curves).

Bypassing the supplies and bias voltage pins requires no special care. For accurate settling, a 0.1 μ F capacitor within an inch or two of the package works well.

Input Characteristics

The inputs of the LT1311 are low impedance summing nodes. The current feedback amplifiers in the LT1311 have an open-loop input impedance of only a few hundred ohms and therefore the closed-loop response is fairly independent of stray capacitance on the inputs. This is a significant advantage over voltage feedback amplifiers that have to be set up for a particular input capacitance. The LT1311 settles cleanly with any input capacitance from zero to 50pF as shown in the characteristic curves. When the LT1311 is used to convert photo diode currents to signal voltages, the LT1311 does not have to be located close to the diodes.

Output Characteristics

The outputs of the LT1311 are complementary emitter followers. The outputs will swing to within 1V of the supplies with no load, 1.2V delivering 10mA. The outputs are short-circuit protected with a 55mA current limit.

Voltage Gain Applications

When the LT1311 is used with external input resistors to make an inverting voltage gain amplifier, the bandwidth remains fairly constant for gains of 10 or less. At high gains the bandwidth is limited by a gain bandwidth product of about 250MHz. See the characteristic curves for details.

The bandwidth is also influenced by any stray capacitance in parallel with the input resistor. The parallel stray capacitance results in a zero that pushes out the bandwidth. This is particularly noticeable with large input resistors that give gains less than one. For example, a single 100k input resistor results in a bandwidth of 14MHz but two 50k resistors in series result in only 10MHz bandwidth.

Overload Recovery

When one or more of the outputs is driven into the rail it will not affect the other amplifiers. However, the output that hit the rail will generate a glitch and take one to two microseconds to recover. Supply current will increase 2mA to 3mA for each amplifier while it is driven into the rail.

TYPICAL APPLICATIONS

Basic Optical System Focus and Tracking Signal Generation

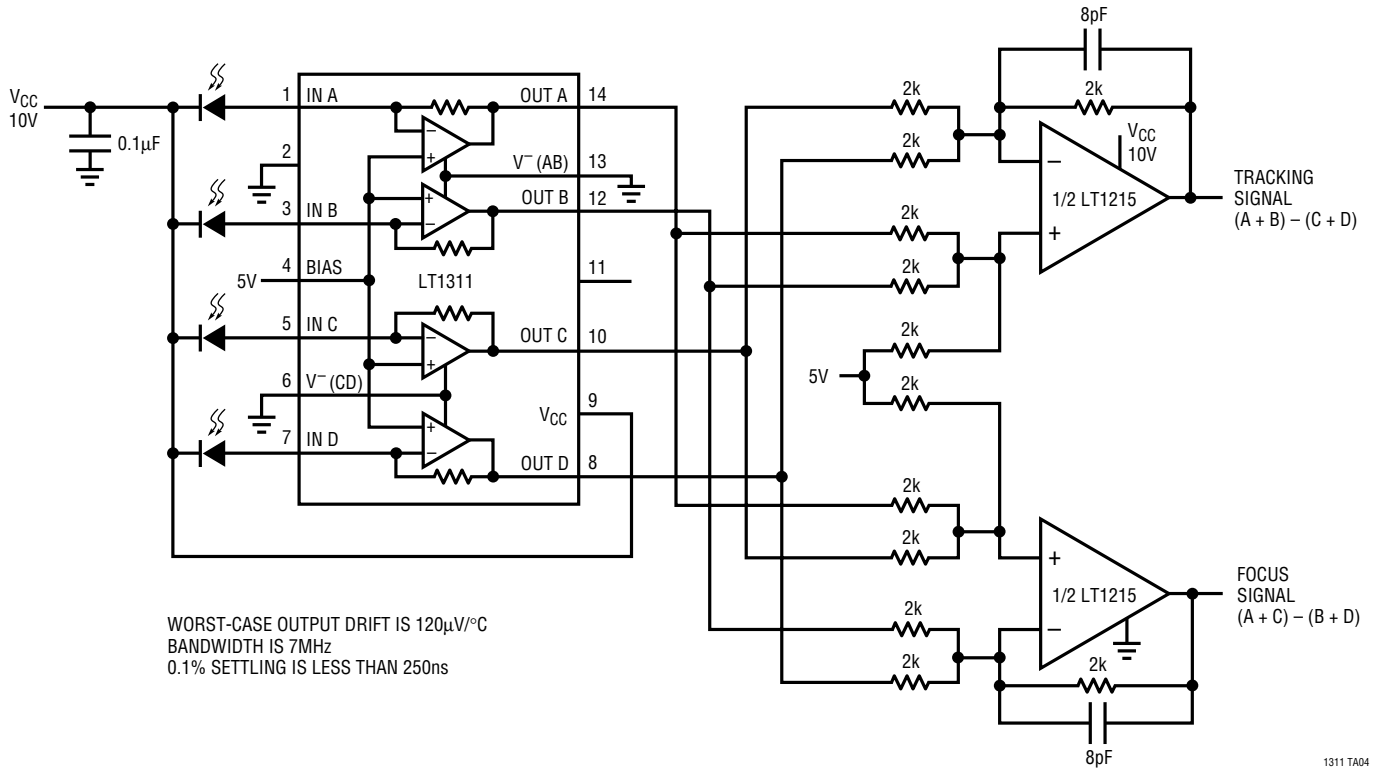

Wide Common-Mode Range Instrumentation Amplifier

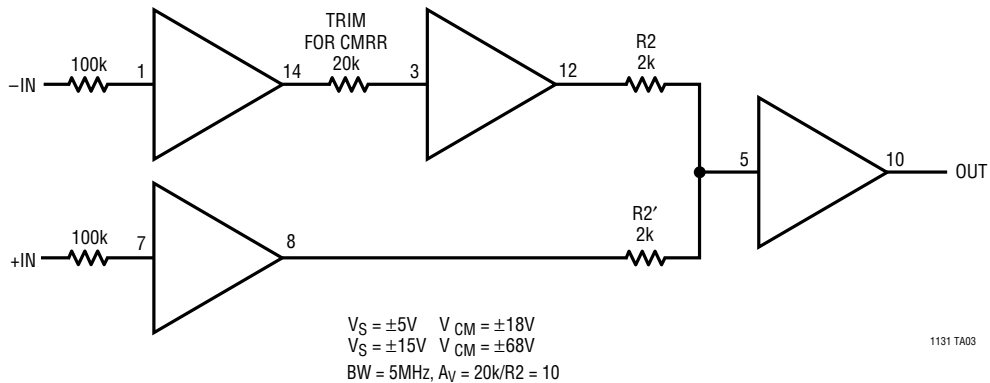

PACKAGE DESCRIPTION

Dimension in inches (millimeters) unless otherwise noted.

**S Package
14-Lead Plastic SOIC**

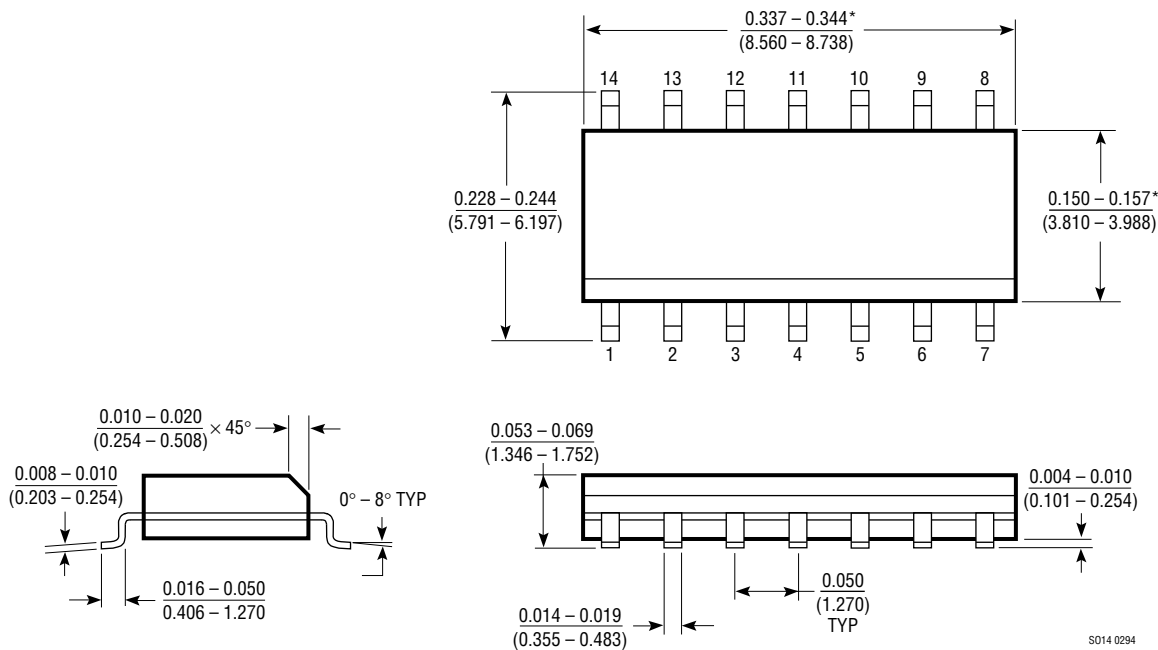

S014-0294

*THESE DIMENSIONS DO NOT INCLUDE MOLD FLASH OR PROTRUSIONS.
MOLD FLASH OR PROTRUSIONS SHALL NOT EXCEED 0.006 INCH (0.15mm)

RELATED PARTS

PART NUMBER	DESCRIPTION	COMMENTS
LT1113	Dual Low Noise, Precision, JFET Input Op Amp	Lowest Voltage Noise FET Op Amp
LT1169	Dual Low Noise, Picoampere Bias Current, JFET Input Op Amp	5pA Input Bias Current
LT1213/LT1214	28MHz, 12V/ μ s, Single Supply, Dual and Quad Precision Op Amps	Highest Bandwidth, Precision Single Supply Op Amps
LT1215/LT1216	23MHz, 50V/ μ s Single Supply, Dual and Quad Precision Op Amps	Fastest Settling, Precision Single Supply Op Amps
LT1222	Low Noise, Very High Speed Op Amp	External Compensation and Output Clamping