

TQM4M9073

Through Line



Applications

- General Purpose Wireless
- RF bypass paths
- Microwave Radio
- Test & Measurement
- Scientific Instruments

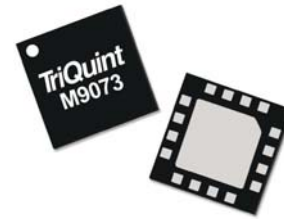

16-pin 3x3mm leadless SMT package

Product Features

- DC – 6 GHz
- 50 ohm port impedance
- Low insertion loss, <0.1dB at 2.14GHz
- 1.2:1 VSWR at 2.14 GHz
- Surface Mountable

Functional Block Diagram

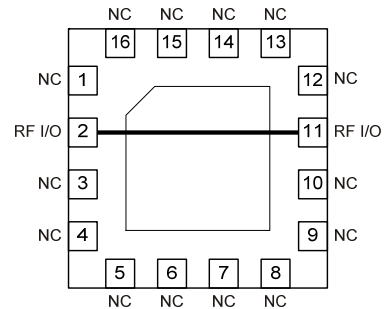

General Description

The TQM4M9073 is a passive low-loss through line that operates from 0 to 6.0 GHz. At 2.14 GHz, input and output return loss is greater than 22 dB and typical insertion loss is 0.1 dB. The product is housed in an industry standard Pb-free / RoHS-compliant surface-mount leadless package.

Pin Configuration

Pin #	Symbol
2, 11	RF I/O
1, 3, 4, 5, 6, 7, 8, 9, 10, 12, 13, 14, 15, 16	No Connect
Backside Paddle	No Connect

Typical Performance

Parameter	Units	Typical Value			
Frequency	MHz	960	2140	2500	3000
Insertion Loss	dB	<0.1	0.1	0.13	0.17
Input/ Output Return Loss	dB	32	25	23	20

Ordering Information

Part No.	Description
TQM4M9073	Through Line

Standard T/R size = 2500 pcs. on a 7" reel

TQM4M9073

Through Line

Specifications

Electrical Specifications

Parameter	Conditions	Min	Typical	Max	Units
Operational Frequency Range	$T_{LEAD} = +25^{\circ}C$	0		6	GHz
Port Impedance (0 to 6 GHz)			50		Ω
Insertion Loss	$f = 2140$ MHz		0.1	0.3	dB
Return Loss			25		dB

Absolute Maximum Ratings

Parameter	Rating
Storage Temperature	-55 to +150 °C
Recommended Operating Temperature Range	-40 to +150 °C

Operation of this device outside the parameter ranges given above may cause permanent damage

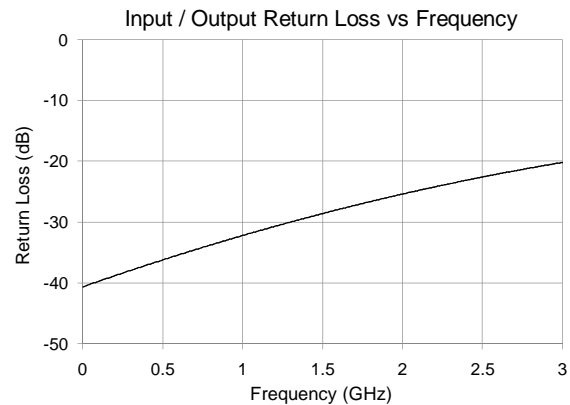
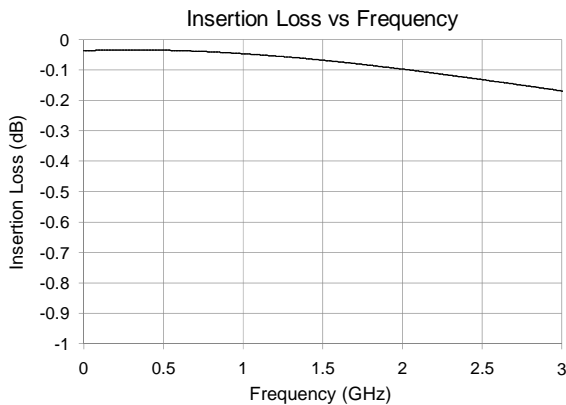

Note: Insertion loss data represents TQM4M9073 performance with PCB losses de-embedded. Insertion loss measured on a PCB will exhibit the loss contributions of the PCB material.

Pin Description

Pin	Symbol	Description
2, 11	RF I/O	RF through path (bi-directional)
1, 3, 4, 5, 6, 7, 8, 9, 10, 12, 13, 14, 15, 16 Backside paddle	NC	No electrical connection. Land pads should be provided for PCB mounting integrity.

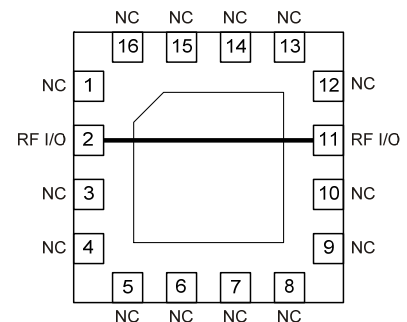

TQM4M9073

Through Line

Mechanical Information

Package Information and Dimensions

Package Style: 16-pin 3X3 leadless SMT

This package is lead-free/RoHS-compliant. The plating material on the leads is ENIG (Electroless Nickel Immersion Gold). It is compatible with both lead-free (maximum 260 °C reflow temperature) and lead (maximum 245 °C reflow temperature) soldering processes.

NOTES:

- EXCEPT WHERE NOTED, THIS PART OUTLINE CONFORMS TO JEDEC STANDARD MO-220, ISSUE E (VARIATION VGGC) FOR THERMALLY ENHANCED PLASTIC VERY THIN FINE PITCH QUAD FLAT NO LEAD PACKAGE (QFN).
- DIMENSIONING & TOLERANCING CONFORM TO ASME Y14.4M-1994.
- ALL DIMENSIONS ARE IN MILLIMETERS. ANGLES ARE IN DEGREES.

- △4 THE TERMINAL #1 IDENTIFIER AND TERMINAL NUMBERING CONVENTION CONFORM TO JESD 95-1 SPP-012.
- △5 COPLANARITY APPLIES TO THE EXPOSED GROUND/THERMAL PAD AS WELL AS THE TERMINALS.
- △6 PRODUCT CODE.
- △7 ALPHA-NUMERIC LOT CODE.
- △8 ASSEMBLY CODE.

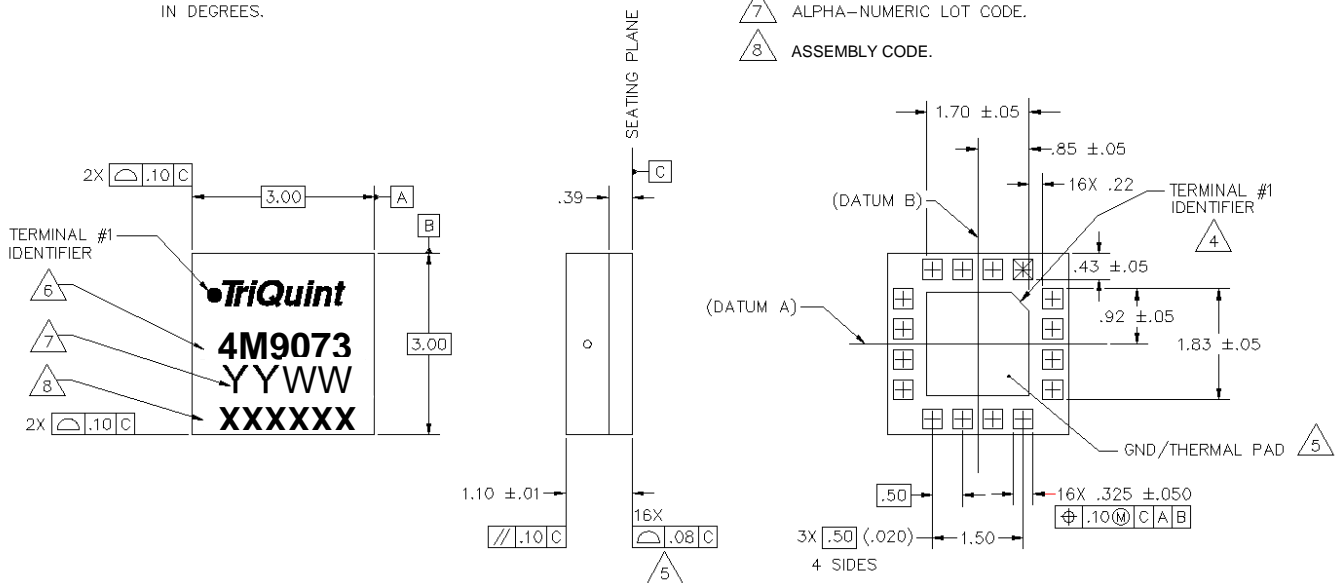

PART MARKING

Pin 1 Location: Upper Left Hand Corner

Line 1 – Pin 1 (orientation) dot & “TriQuint”

Line 2 – Product Name: “4M9073”

Line 3 – YYWW = Year/Week

Line 4 – Assembly Code

Mounting Configuration

All dimensions are in millimeters (inches). Angles are in degrees.

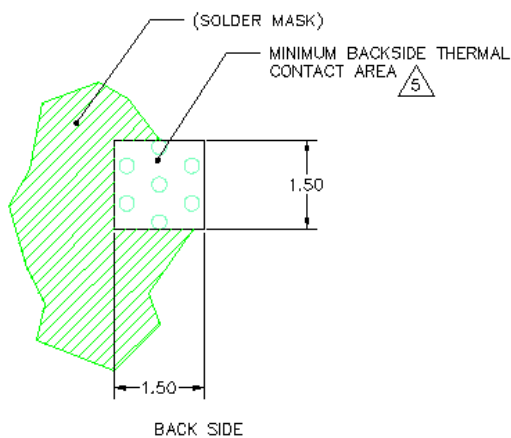
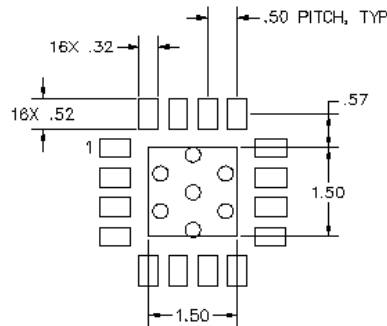
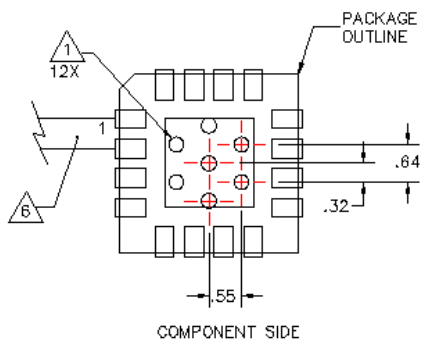

NOTES:

1. GROUND/THERMAL VIAS ARE CRITICAL FOR THE PROPER PERFORMANCE OF THIS DEVICE. VIAS SHOULD USE A .35mm (#80/.0135") DIAMETER DRILL AND HAVE A FINAL, PLATED THRU DIAMETER OF .25mm (.010").
2. ADD AS MUCH COPPER AS POSSIBLE TO INNER AND OUTER LAYERS NEAR THE PART TO ENSURE OPTIMAL THERMAL PERFORMANCE.
3. TO ENSURE RELIABLE OPERATION, DEVICE GROUND PADDLE-TO-GROUND PAD SOLDER JOINT IS CRITICAL.
4. ADD MOUNTING SCREWS NEAR THE PART TO FASTEN THE BOARD TO A HEATSINK. ENSURE THAT THE GROUND/THERMAL VIA REGION CONTACTS THE HEATSINK.
5. DO NOT PUT SOLDER MASK ON THE BACK SIDE OF THE PC BOARD IN THE REGION WHERE THE BOARD CONTACTS THE HEATSINK.
6. RF TRACE WIDTH DEPENDS UPON THE PC BOARD MATERIAL AND CONSTRUCTION.
7. USE 1 OZ. COPPER MINIMUM.
8. ALL DIMENSIONS ARE IN MILLIMETERS. ANGLES ARE IN DEGREES.

MANUFACTURING ENVIRONMENTS

COMPONENT HANDLING

All necessary special handling techniques shall be adopted in order to avoid contamination of metallization / terminations. Examples include use of finger cots, plastic tweezers, etc.

PART PLACEMENT

A placement force of up to 500 grams is applied (using a 2.00 mm or a 0.080 inch diameter rod) to the center of the part while remaining in its tape carrier.

COMPONENT SOLDERABILITY

Convection or Infrared Reflow

Part will comply with convection or infrared reflow soldering processes consistent with IPC/JEDEC J-STD-020. TriQuint's actual reflow profile for qualification is provided below:

Reflow Parameters	IPC/JEDEC J-STD-020	TriQuint Actual
Average ramp-up rate (217°C to Peak)	3°C/second max.	0.57°C/second
Preheat Time (150°C to 200°C)	60-180 seconds	150 seconds
Time above 217°C	60-150 seconds	126 seconds
Peak Temperature	260 +0/-5°C	259°C
Time within 5°C of actual Peak Temperature	20-40 seconds	30 seconds
Ramp-down Rate	6°C/second max.	0.875°C/second
Time 25°C to Peak Temperature	8 minutes max.	7 minutes max.

MATERIAL PACKAGING AND SHIPMENT

In the absence of customer specific requirements called out in the purchase order, material packaging and shipping requirements shall be defined in the paragraph and in TriQuint's standard procedure for the packaging and shipment of ICs in tape and reel.

GENERAL TAPE AND REEL REQUIREMENTS

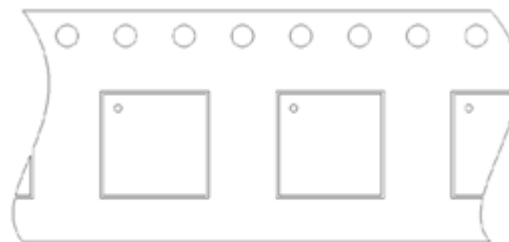

MODULE 3X3

User Direction of Feed →

Carrier and cover tape physical dimensions

TQM4M9073

Through Line

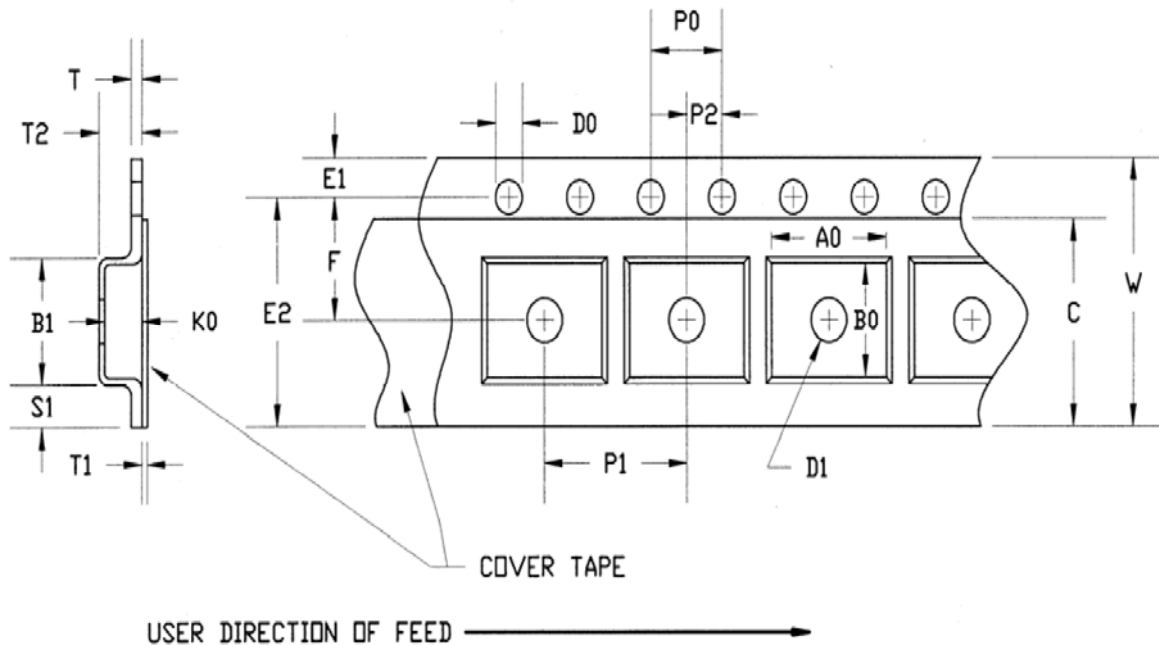

PART	FEATURE	SYMBOL	SIZE (in)	SIZE (mm)
CAVITY	LENGTH	A0	0.134	3.40
	WIDTH	B0	0.126	3.20
	DEPTH	K0	0.055	1.40
	PITCH	P1	0.157	4.00
DISTANCE BETWEEN CENTERLINE	CAVITY TO PERFORATION LENGTH DIRECTION	P2	0.079	2.00
	CAVITY TO PERFORATION WIDTH DIRECTION	F	0.138	3.50
COVER TAPE	WIDTH	C	0.213	5.40
CARRIER TAPE	WIDTH	W	0.315	8.00

ESD PROTECTION

To protect the devices and leads from ESD damage, individual parts shall be placed in static protected tape and reels, tubes, bags, trays, or in waffle packages.

MOISTURE RESISTANT PACKAGING

The product will be shipped in accordance with JEDEC J-STD-033 where applicable.

Product Compliance Information

MSL Rating

The part is rated Moisture Sensitivity Level 3 at 260°C per JEDEC standard IPC/JEDEC J-STD-020.

Solderability

Compatible with the latest version of J-STD-020, Lead free solder, 260°

This part is compliant with EU 2002/95/EC RoHS directive (Restrictions on the Use of Certain Hazardous Substances in Electrical and Electronic Equipment).

This product also has the following attributes:

- Lead Free
- Halogen Free (Chlorine, Bromine)
- Antimony Free
- TBBP-A (C₁₅H₁₂Br₄O₂) Free
- PFOS Free
- SVHC Free

Contact Information

For the latest specifications, additional product information, worldwide sales and distribution locations, and information about TriQuint:

Web: www.triquint.com
Email: info-sales@tqs.com

Tel: +1.503.615.9000
Fax: +1.503.615.8902

For technical questions and application information:

Email: sjapplications.engineering@tqs.com

Important Notice

The information contained herein is believed to be reliable. TriQuint makes no warranties regarding the information contained herein. TriQuint assumes no responsibility or liability whatsoever for any of the information contained herein. TriQuint assumes no responsibility or liability whatsoever for the use of the information contained herein. The information contained herein is provided "AS IS, WHERE IS" and with all faults, and the entire risk associated with such information is entirely with the user. All information contained herein is subject to change without notice. Customers should obtain and verify the latest relevant information before placing orders for TriQuint products. The information contained herein or any use of such information does not grant, explicitly or implicitly, to any party any patent rights, licenses, or any other intellectual property rights, whether with regard to such information itself or anything described by such information.

TriQuint products are not warranted or authorized for use as critical components in medical, life-saving, or life-sustaining applications, or other applications where a failure would reasonably be expected to cause severe personal injury or death.