



MT7681

802.11 b/g/n single chip

Preliminary datasheet

Version: 0.00
Release date: 2014-01-08

© 2010 - 2014 MediaTek Inc.

This document contains information that is proprietary to MediaTek Inc.

Unauthorized reproduction or disclosure of this information in whole or in part is strictly prohibited.

Specifications are subject to change without notice.

Document Revision History

Revision	Date	Author	Description
0.00	2014/01/08	Alex Lin	First formal release

Table of Contents

Document Revision History	2
Table of Contents	3
1 System Overview.....	4
1.1 General Descriptions	4
1.2 Features	4
1.3 Applications	5
1.4 Block Diagram	5
2 Product Descriptions	6
2.1 Pin Layout	6
2.2 PIN Description	7
2.3 Strapping option	9
2.4 Package Information.....	10
2.4.1 QFN Packaging	10
2.5 Ordering Information.....	12
3 Electrical characteristics	13
3.1 Absolute maximum rating	13
3.2 Recommended operating range	13
3.3 DC characteristics	13
3.4 Thermal characteristics	13
3.5 Current consumption	14

1 System Overview

1.1 General Descriptions

The MT7681 is a highly integrated Wi-Fi SoC(system on Chip) single chip, which supports IEEE802.11b/g/n single stream, providing GPIO and PWM for intelligent control, and UART, SPI, and I2C interfaces for device communication.

The MT7681 integrate power amplifier, low noise amplifier, and RF switch to reduce the module size and RF design capability required. And also integrate power manage unit for single 3.3V power source for cost effective design.

The MT7681 embedded 32-bit RISC MCU for 802.11b/g/n drivers, supplicant, TCP/IP protocol stack, and networking applications, can be operated in station mode and softAP mode. The MT7681 is an ideal solution for embedded device to enable networking service with minimized design effort.

All the features are available in compact 40pin, 5x5mm QFN package.

1.2 Features

- Single stream IEEE 802.11 b/g/n
- 32-bit RISC microprocessor as the host MCU
- Embedded IEEE 802.11b/g/n drivers, supplicant, and TCP/IP stack
- Highly integrated RF PA, LNA, and RF switch
- Integrate high efficiency switching regulator for single 3.3V power source
- Security support for WPA/WPA2 personal, WPS2.0, WAPI
- Operation in station mode or softAP mode
- Rich interfaces, UART, SPI, I2C, PWM and GPIOs
- All functions integrates in compact 5mm x 5mm QFN40L package
- UART interface

1.3 Applications

- Home automation
- Smart plug
- Lighting
- Metering
- Remote control
- Network consumer devices

1.4 Block Diagram

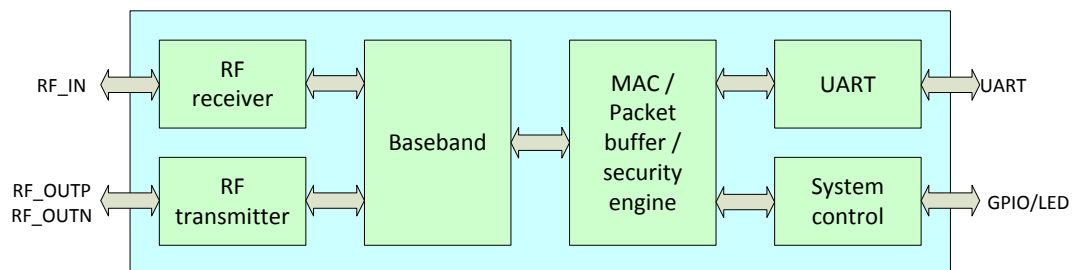

Figure 1 MT7681 block diagram

2 Product Descriptions

2.1 Pin Layout

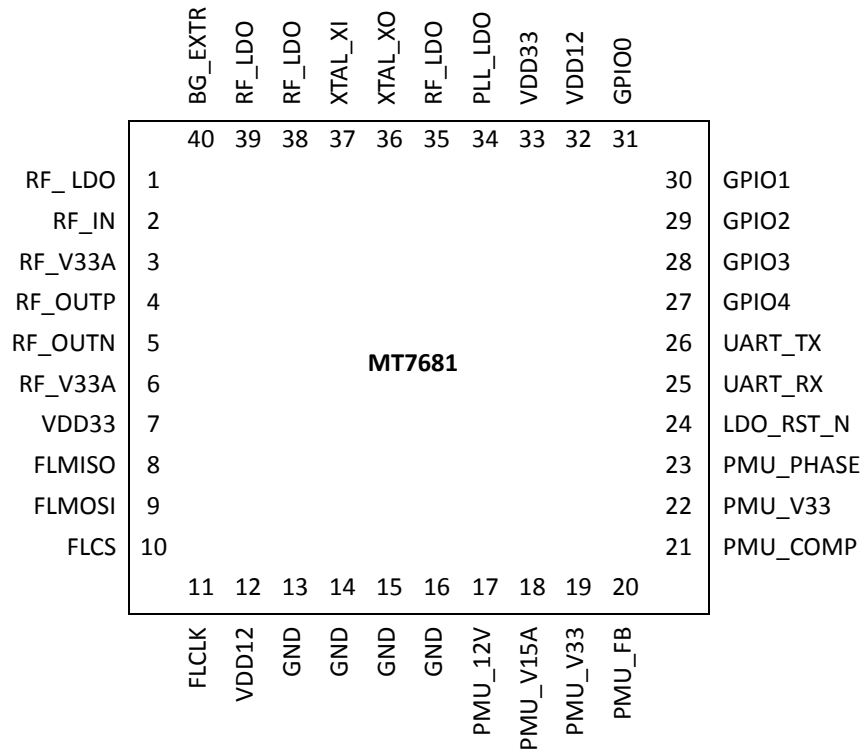

Figure 2 Top view of MT7681 QFN pin-out.

2.2 PIN Description

QFN40	Pin Name	Pin description	Default PU/PD	I/O	Supply domain
Reset and clocks					
24	LDO_RST_N	External system reset active low	N/A	Input	VDD33
37	XTAL_XI	Crystal input or external clock input	N/A	Input	
36	XTAL_XO	Crystal output	N/A	Input	
UART interface					
25	UART_TX	UART TX	N/A		VDD33
26	UART_RX	UART RX	N/A		VDD33
FLASH interface					
8	EE_MISO	External memory data input / Antenna select	PD	Input	VDD33
9	EE_MOSI	External memory data output / Antenna select	PD	Output	VDD33
10	EE_CS	External chip select	PU	Output	VDD33
11	EEFL_CLK	External clock	PU	Output	VDD33
Programmable I/O					
30	GPIO0	Programmable input/output	PD	In/out	VDD33
31	GPIO1	Programmable input/output	PD	In/out	VDD33
29	GPIO2	Programmable input/output	PD	In/out	VDD33
28	GPIO3	Programmable input/output	PD	In/out	VDD33
27	GPIO4	Programmable input/output	PD	In/out	VDD33
WIFI radio interface					
40	BG_EXTR	RF BG reference	N/A		
2	RF_IN	RF auxiliary RX input	N/A		
4	RF_OUTP	RF port	N/A		
5	RF_OUTN	RF port	N/A		
PMU					
17	PMU_12V	PMU 1.2V output	N/A	Output	
18	PMU_V15A	PMU 1.5V input	N/A	lutput	
19,22	PMU_V33	PMU 3.3V power supply	N/A	Input	
20	PMU_FB	PMU control	N/A		
21	PMU_COMP	PMU control	N/A		
23	PMU_PHASE	PMU control	N/A		
Power supplies					
7,33	VDD33	Digital I/O power supply	N/A	Input	

12,32	VDD12	Digital core power supply	N/A	Input	
3,6	RF_V33A	RF 3.3V power supply	N/A	Input	
1,35, 38,39	RF_LDO	RF power supply	N/A	Input	
34	PLL_LDO	RF power supply	N/A	Input	
E-PAD	DVSS	Digital ground	N/A		

Table 1 Pin descriptions

2.3 Strapping option

QFN40	Pin Name	Pin description	Default PU/PD
8	FLMISO	XTAL_20_SEL XTAL is 20MHz: Pull up XTAL is 40MHz: Pull down	PD
27	GPIO4	EXT_EE_SEL: Pull down	PD
25	UART_RX	CHIP_MODE[2]: Pull down	PD
11	FLCLK	CHIP_MODE[1]: Pull up	PD
9	FLMOSI	CHIP_MODE[0]: Pull down	PU

Table 2 Strapping option

2.4 Package Information

2.4.1 QFN Packaging

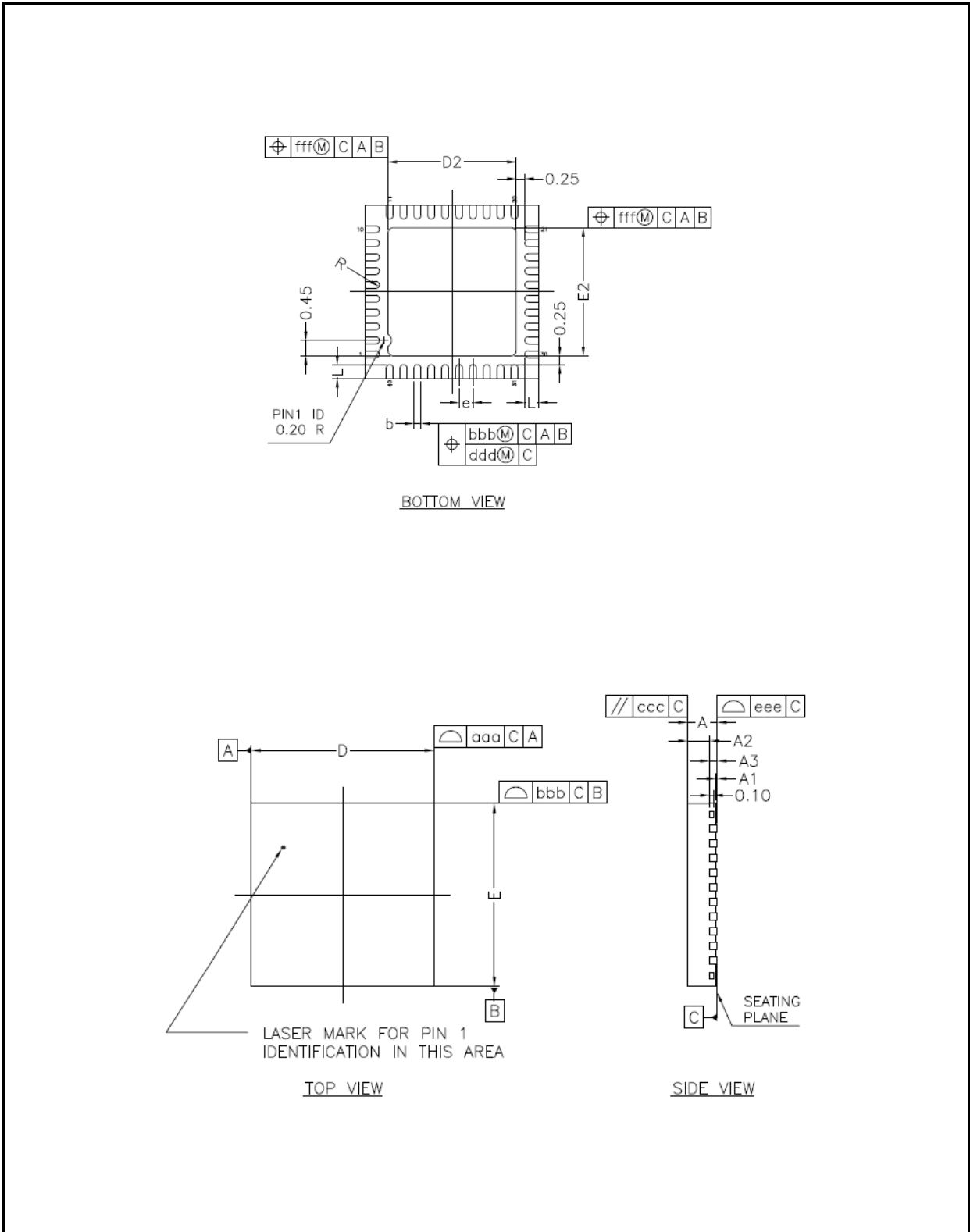

* CONTROLLING DIMENSION : MM

SYMBOL	MILLIMETER			INCH		
	MIN.	NOM.	MAX.	MIN.	NOM.	MAX.
A	----	----	0.80	----	----	0.031
A1	----	----	0.05	----	----	0.002
A2	----	0.53	0.58	----	0.021	0.023
A3	0.20 REF.			0.008 REF.		
b	0.15	0.20	0.25	0.006	0.008	0.010
D	5.00 bsc			0.197 bsc		
D2	3.55	3.70	3.85	0.140	0.146	0.152
E	5.00 bsc			0.197 bsc		
E2	3.55	3.70	3.85	0.140	0.146	0.152
L	0.30	0.40	0.50	0.012	0.016	0.020
e	0.40 bsc			0.016 bsc		
R	0.075	----	----	0.003	----	----
TOLERANCES OF FORM AND POSITION						
aaa	0.10			0.004		
bbb	0.07			0.003		
ccc	0.10			0.004		
ddd	0.05			0.002		
eee	0.08			0.003		
fff	0.10			0.004		

NOTES :

- 1.ALL DIMENSIONS ARE IN MILLIMETERS.
- 2.DIE THICKNESS ALLOWABLE IS 0.305 mm MAXIMUM(.012 INCHES MAXIMUM)
- 3.DIMENSIONING & TOLERANCES CONFORM TO ASME Y14.5M. -1994.
- 4.THE PIN #1 IDENTIFIER MUST BE PLACED ON THE TOP SURFACE OF THE PACKAGE BY USING INDENTATION MARK OR OTHER FEATURE OF PACKAGE BODY.
- 5.EXACT SHAPE AND SIZE OF THIS FEATURE IS OPTIONAL.
- 6.PACKAGE WARPAGE MAX 0.08 mm.
- 7.APPLIED FOR EXPOSED PAD AND TERMINALS. EXCLUDE EMBEDDING PART OF EXPOSED PAD FROM MEASURING.
- 8.APPLIED ONLY TO TERMINALS.

Figure 3 Package outline drawing

2.5 Ordering Information

Part number	Package	Operational temperature range
MT7681N	5x5x0.8 mm 40-QFN	-10~70°C

Table 3 Ordering information

2.6 TOP Marking Information



Figure 4 Top marking

3 Electrical characteristics

3.1 Absolute maximum rating

Symbol	Parameters	Maximum rating	Unit
VDD33	3.3V Supply Voltage	-0.3 to 3.6	V
VDD12	1.2V Supply Voltage	-0.3 to 1.5	V
VDD15	1.5V Supply Voltage	-0.3 to 1.8	V
T _{STG}	Storage Temperature	-40 to +125	°C
VESD	ESD protection (HBM)	2000	V

Table 4 Absolute maximum ratings

3.2 Recommended operating range

Symbol	Rating	MIN	TYP	MAX	Unit
VDD33	3.3V Supply Voltage	2.97	3.3	3.63	V
VDD12	1.2V Supply Voltage	1.14	1.2	1.26	V
VDD15	1.5V Supply Voltage	1.425	1.5	1.575	V
T _{AMBIENT}	Ambient Temperature	-10	-	70	°C

Table 5 Recommended operating range

3.3 DC characteristics

Symbol	Parameter	Conditions	MIN	MAX	Unit
V _{IL}	Input Low Voltage	LVTTL	-0.28	0.6	V
V _{IH}	Input High Voltage		2.0	3.63	V
V _{T-}	Schmitt Trigger Negative Going Threshold Voltage	LVTTL	0.68	1.36	V
V _{T+}	Schmitt Trigger Positive Going Threshold Voltage		1.36	1.7	V
V _{OL}	Output Low Voltage	I _{OL} = 1.6~14 mA	-0.28	0.4	V
V _{OH}	Output High Voltage	I _{OH} = 1.6~14 mA	2.4	VDD33+0.33	V
R _{PU}	Input Pull-Up Resistance	PU=high, PD=low	40	190	KΩ
R _{PD}	Input Pull-Down Resistance	PU=low, PD=high	40	190	KΩ

Table 6 DC description

3.4 Thermal characteristics

Symbol	Description	Performance	
		TYP	Unit
T _J	Maximum Junction Temperature (Plastic Package)	125	°C
Θ _{JA}	Junction to ambient temperature thermal resistance ^{[1][2]}	48.11	°C/W
Θ _{JC}	Junction to case temperature thermal resistance	TBD	°C/W

Ψ_{Jt}	Junction to the package thermal resistance ^[3]	3.23	°C/W
-------------	---	------	------

Note:

[1] Air flow condition: Natural convection. 0.5m/s.

[2] PCB dimension 21mm x 11mm. 4-layer.

[3] 5mm x 5mm QFN40L package

Table 7 Thermal information

3.5 Current consumption

Description	Performance	
	TYP	Unit
Sleep mode	1.1	mA
RX Active, HT40, MCS7	151	mA
RX Power saving, DTIM=1	15	mA
RX Listen	6	mA
TX HT40, MCS7 @15dBm	210	mA
TX CCK, 11Mbps @19dBm	242	mA

Note: All result is measured at the antenna port and VDD33 is 3.3V

Table 8 WLAN 2.4GHz Current Consumption



ESD CAUTION

MT7681 is ESD (electrostatic discharge) sensitive device and may be damaged with ESD or spike voltage. Although MT7681 is with built-in ESD protection circuitry, please handle with care to avoid the permanent malfunction or the performance degradation.