

BLM7G1822S-40AB; BLM7G1822S-40ABG

LDMOS 2-stage power MMIC

Rev. 1 — 10 July 2015

Product data sheet

1. Product profile

1.1 General description

The BLM7G1822S-40AB(G) is a dual section, asymmetric, 2-stage power MMIC using NXP's state of the art GEN7 LDMOS technology. This multiband device is perfectly suited as small cell final in Doherty configuration, or as general purpose driver in the 1805 MHz to 2170 MHz frequency range. Available in gull wing or straight lead outline.

Table 1. Performance

Typical RF performance at $T_{case} = 25\text{ °C}$; $I_{Dq1} = 20\text{ mA}$; $I_{Dq2} = 76\text{ mA}$ for carrier section: $I_{Dq1} = 40\text{ mA}$ and $I_{Dq2} = 120\text{ mA}$ for peaking section.

Test signal: 3GPP test model 1; single carrier W-CDMA; 64 DPCH; PAR = 9.9 dB at 0.01% probability on CCDF; per section in a class-AB production circuit.

Test signal	f	V _{DS}	P _{L(AV)}	G _p	η _D	ACPR _{5M}
	(MHz)	(V)	(W)	(dB)	(%)	(dBc)
single carrier W-CDMA						
carrier section	2167.5	28	2	31.5	25.5	-37
peaking section	2167.5	28	4	31.5	26.5	-38

1.2 Features and benefits

- Designed for broadband operation (frequency 1805 MHz to 2170 MHz)
- High section-to-section isolation enabling multiple combinations
- High Doherty efficiency thanks to 2 : 1 asymmetry
- Integrated temperature compensated bias
- Biasing of individual stages is externally accessible
- Integrated ESD protection
- Excellent thermal stability
- High power gain
- On-chip matching for ease of use
- Compliant to Directive 2002/95/EC, regarding restriction of hazardous substances (RoHS)

1.3 Applications

- RF power MMIC for W-CDMA base stations in the 1805 MHz to 2170 MHz frequency range. Possible circuit topologies are the following as also depicted in [Section 8.1](#):
 - ◆ Asymmetric final stage in Doherty configuration
 - ◆ Asymmetric driver for high power Doherty amplifier



2. Pinning information

2.1 Pinning

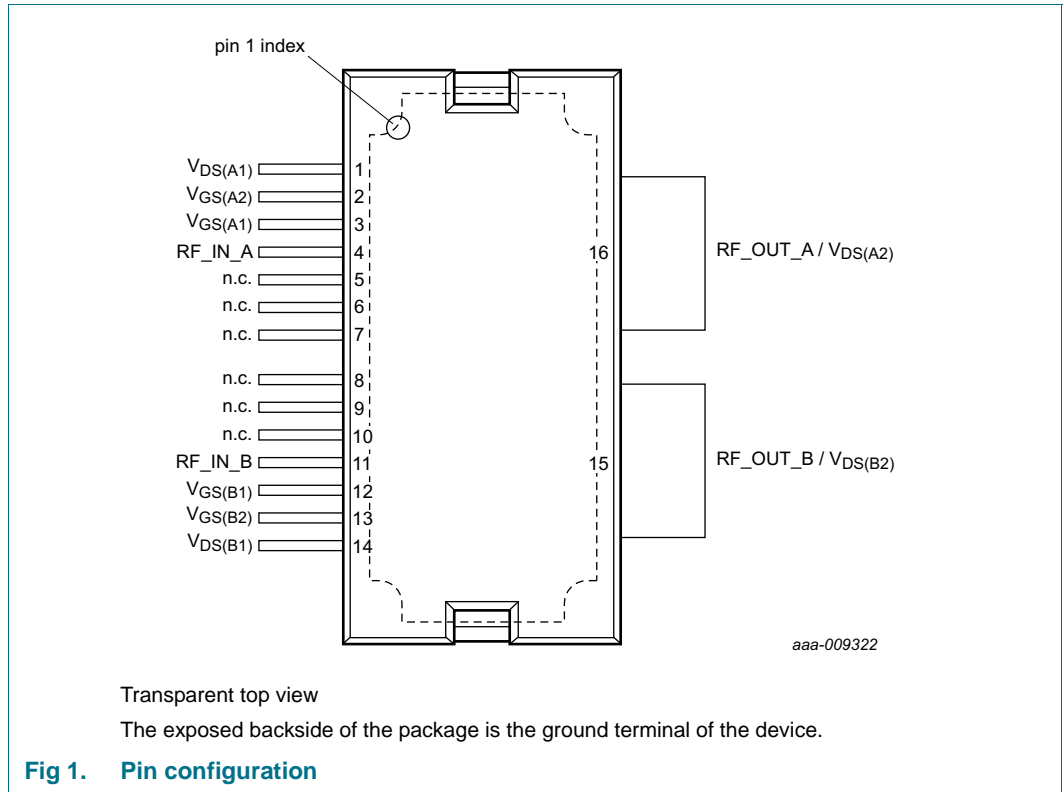

2.2 Pin description

Table 2. Pin description

Symbol	Pin	Description
$V_{DS(A1)}$	1	drain-source voltage of carrier section, driver stage (A1)
$V_{GS(A2)}$	2	gate-source voltage of carrier section, final stage (A2)
$V_{GS(A1)}$	3	gate-source voltage of carrier section, driver stage (A1)
RF_IN_A	4	RF input carrier section (A)
n.c.	5	not connected
n.c.	6	not connected
n.c.	7	not connected
n.c.	8	not connected
n.c.	9	not connected
n.c.	10	not connected
RF_IN_B	11	RF input peaking section (B)
$V_{GS(B1)}$	12	gate-source voltage of peaking section, driver stage (B1)
$V_{GS(B2)}$	13	gate-source voltage of peaking section, final stage (B2)
$V_{DS(B1)}$	14	drain-source voltage of peaking section, driver stage (B1)

Table 2. Pin description ...continued

Symbol	Pin	Description
RF_OUT_B/ $V_{DS(B2)}$	15	RF output peaking section (B) / drain-source voltage of peaking section, final stage (B2)
RF_OUT_A/ $V_{DS(A2)}$	16	RF output carrier section (A) / drain-source voltage of carrier section, final stage (A2)
GND	flange	RF ground

3. Ordering information

Table 3. Ordering information

Type number	Package		Version
	Name	Description	
BLM7G1822S-40AB	HSOP16F	plastic, heatsink small outline package; 16 leads (flat)	SOT1211-2
BLM7G1822S-40ABG	HSOP16	plastic, heatsink small outline package; 16 leads	SOT1212-2

4. Block diagram

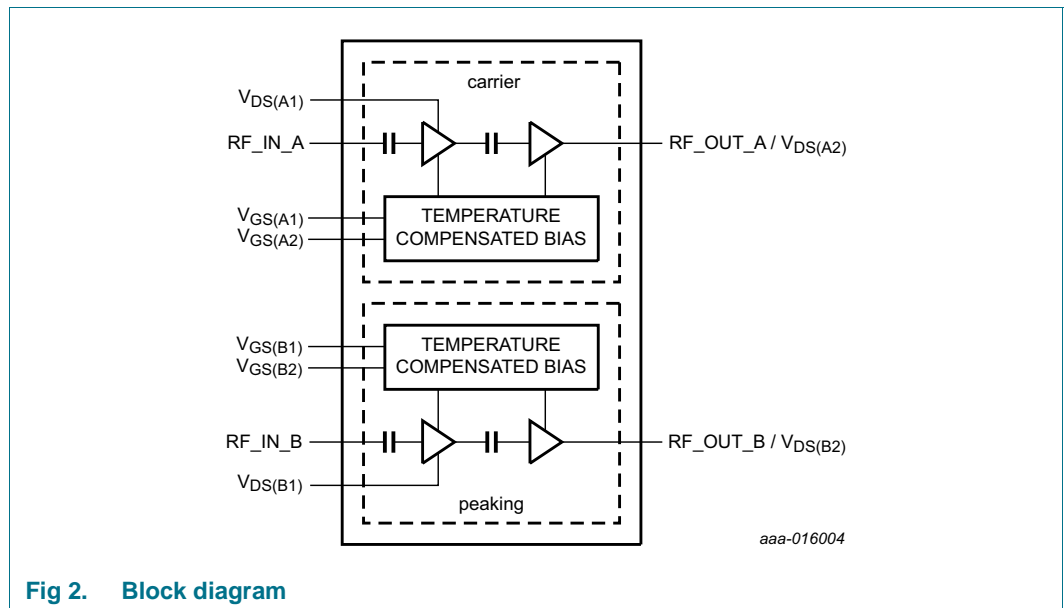

Fig 2. Block diagram

5. Limiting values

Table 4. Limiting values

In accordance with the Absolute Maximum Rating System (IEC 60134).

Symbol	Parameter	Conditions	Min	Max	Unit
V_{DS}	drain-source voltage		-	65	V
V_{GS}	gate-source voltage		-0.5	+13	V

Table 4. Limiting values ...continued

In accordance with the Absolute Maximum Rating System (IEC 60134).

Symbol	Parameter	Conditions	Min	Max	Unit
T _{stg}	storage temperature		-65	+150	°C
T _j	junction temperature		[1]	225	°C
T _{case}	case temperature		-	150	°C

[1] Continuous use at maximum temperature will affect the reliability. For details refer to the online MTF calculator.

6. Thermal characteristics

Table 5. Thermal characteristics

Symbol	Parameter	Conditions	Value	Unit	
Carrier section					
R _{th(j-c)}	thermal resistance from junction to case	final stage; T _{case} = 90 °C; P _L = 1.78 W	[1]	3.8	K/W
		driver stage; T _{case} = 90 °C; P _L = 1.78 W	[1]	12.4	K/W
Peaking section					
R _{th(j-c)}	thermal resistance from junction to case	final stage; T _{case} = 90 °C; P _L = 1.26 W	[1]	2.4	K/W
		driver stage; T _{case} = 90 °C; P _L = 1.26 W	[1]	7.6	K/W

[1] When operated with a CW signal.

7. Characteristics

Table 6. DC characteristics

T_{case} = 25 °C; per section unless otherwise specified.

Symbol	Parameter	Conditions	Min	Typ	Max	Unit
Carrier section						
Final stage						
V _{(BR)DSS}	drain-source breakdown voltage	V _{GS} = 0 V; I _D = 150.8 μA	65	-	-	V
V _{GSq}	gate-source quiescent voltage	V _{DS} = 28 V; I _D = 76 mA	1.6	2.1	2.6	V
		V _{DS} = 28 V; I _D = 76 mA [1]	1.6	2.65	3.5	V
ΔI _{Dq} /ΔT	quiescent drain current variation with temperature	-40 °C ≤ T _{case} ≤ +85 °C [1]	-	±1	-	%
I _{DSS}	drain leakage current	V _{GS} = 0 V; V _{DS} = 28 V	-	-	1.4	μA
I _{DSX}	drain cut-off current	V _{GS} = 5.65 V; V _{DS} = 10 V	-	2.8	-	A
I _{GSS}	gate leakage current	V _{GS} = 1.0 V; V _{DS} = 0 V	-	-	140	nA
Driver stage						
V _{(BR)DSS}	drain-source breakdown voltage	V _{GS} = 0 V; I _D = 30.16 μA	65	-	-	V
V _{GSq}	gate-source quiescent voltage	V _{DS} = 28 V; I _D = 20 mA	1.6	2.15	2.6	V
		V _{DS} = 28 V; I _D = 20 mA [2]	1.6	2.7	3.5	V
ΔI _{Dq} /ΔT	quiescent drain current variation with temperature	-40 °C ≤ T _{case} ≤ +85 °C [2]	-	±1	-	%
I _{DSS}	drain leakage current	V _{GS} = 0 V; V _{DS} = 28 V	-	-	1.4	μA
I _{DSX}	drain cut-off current	V _{GS} = 5.65 V; V _{DS} = 10 V	-	0.55	-	A
I _{GSS}	gate leakage current	V _{GS} = 1.0 V; V _{DS} = 0 V	-	-	140	nA

Table 6. DC characteristics ...continued
T_{case} = 25 °C; per section unless otherwise specified.

Symbol	Parameter	Conditions	Min	Typ	Max	Unit
Peaking section						
Final stage						
V _{(BR)DSS}	drain-source breakdown voltage	V _{GS} = 0 V; I _D = 302 μA	65	-	-	V
V _{GSq}	gate-source quiescent voltage	V _{DS} = 28 V; I _D = 120 mA	1.6	2.1	2.6	V
		V _{DS} = 28 V; I _D = 120 mA [3]	1.6	2.65	3.5	V
ΔI _{Dq} /ΔT	quiescent drain current variation with temperature	-40 °C ≤ T _{case} ≤ +85 °C [3]	-	±1	-	%
I _{DSS}	drain leakage current	V _{GS} = 0 V; V _{DS} = 28 V	-	-	1.4	μA
I _{DSX}	drain cut-off current	V _{GS} = 5.65 V; V _{DS} = 10 V	-	5.4	-	A
I _{GSS}	gate leakage current	V _{GS} = 1.0 V; V _{DS} = 0 V	-	-	140	nA
Driver stage						
V _{(BR)DSS}	drain-source breakdown voltage	V _{GS} = 0 V; I _D = 58 μA	65	-	-	V
V _{GSq}	gate-source quiescent voltage	V _{DS} = 28 V; I _D = 40 mA	1.6	2.15	2.6	V
		V _{DS} = 28 V; I _D = 40 mA [4]	1.6	2.7	3.5	V
ΔI _{Dq} /ΔT	quiescent drain current variation with temperature	-40 °C ≤ T _{case} ≤ +85 °C [4]	-	±1	-	%
I _{DSS}	drain leakage current	V _{GS} = 0 V; V _{DS} = 28 V	-	-	1.4	μA
I _{DSX}	drain cut-off current	V _{GS} = 5.65 V; V _{DS} = 10 V	-	1.04	-	A
I _{GSS}	gate leakage current	V _{GS} = 1.0 V; V _{DS} = 0 V	-	-	140	nA

- [1] In production circuit with 1105.6 Ω gate feed resistor.
- [2] In production circuit with 765 Ω gate feed resistor.
- [3] In production circuit with 825.6 Ω gate feed resistor.
- [4] In production circuit with 850 Ω gate feed resistor.

Table 7. RF Characteristics

Typical RF performance at T_{case} = 25 °C; V_{DS} = 28 V; I_{Dq1} = 20 mA (carrier section, driver stage); I_{Dq2} = 76 mA (carrier section, final stage); P_{L(AV)} = 2 W (carrier section); I_{Dq1} = 40 mA (peaking section, driver stage); I_{Dq2} = 120 mA (peaking section, final stage); P_{L(AV)} = 4 W (peaking section) unless otherwise specified, measured in an NXP straight lead production circuit.

Symbol	Parameter	Conditions	Min	Typ	Max	Unit
Carrier section						
Test signal: single carrier W-CDMA [1]						
G _p	power gain	f = 1807.5 MHz	-	31.8	-	dB
		f = 2167.5 MHz	30	31.5	33	dB
η _D	drain efficiency	f = 1807.5 MHz	-	18	-	%
		f = 2167.5 MHz	21	25.5	-	%
RL _{in}	input return loss	f = 2167.5 MHz	-	-15	-10	dB
ACPR _{5M}	adjacent channel power ratio (5 MHz)	f = 1807.5 MHz	-	-39	-	dBc
		f = 2167.5 MHz	-	-37	-33	dBc
PAR _O	output peak-to-average ratio	f = 1807.5 MHz	-	8.4	-	dB
		f = 2167.5 MHz	6.4	7.7	-	dB

Table 7. RF Characteristics ...continued

Typical RF performance at $T_{case} = 25\text{ °C}$; $V_{DS} = 28\text{ V}$; $I_{Dq1} = 20\text{ mA}$ (carrier section, driver stage); $I_{Dq2} = 76\text{ mA}$ (carrier section, final stage); $P_{L(AV)} = 2\text{ W}$ (carrier section); $I_{Dq1} = 40\text{ mA}$ (peaking section, driver stage); $I_{Dq2} = 120\text{ mA}$ (peaking section, final stage); $P_{L(AV)} = 4\text{ W}$ (peaking section) unless otherwise specified, measured in an NXP straight lead production circuit.

Symbol	Parameter	Conditions	Min	Typ	Max	Unit
Peaking section						
Test signal: single carrier W-CDMA [1]						
G _p	power gain	f = 1807.5 MHz	-	31.3	-	dB
		f = 2167.5 MHz	30	31.5	33	dB
η _D	drain efficiency	f = 1807.5 MHz	-	25.5	-	%
		f = 2167.5 MHz	22	26.5	-	%
RL _{in}	input return loss	f = 2167.5 MHz	-	-20	-10	dB
ACPR _{5M}	adjacent channel power ratio (5 MHz)	f = 1807.5 MHz	-	-41	-	dBc
		f = 2167.5 MHz	-	-38	-34	dBc
PAR _O	output peak-to-average ratio	f = 1807.5 MHz	-	8.2	-	dB
		f = 2167.5 MHz	6.5	7.9	-	dB
Test signal: CW [2]						
Δφ _{s21}	phase response difference	normalized; between sections	-10	-	+10	deg
Δ S ₂₁ ²	insertion power gain difference	normalized; between sections	-0.5	-	+0.5	dB

[1] 3GPP test model 1; 64 DPCH; PAR = 9.9 dB at 0.01% probability on CCDF.

[2] f = 2170 MHz.

8. Application information

Table 8. Typical performance

$T_{case} = 25\text{ °C}$; $V_{DS} = 28\text{ V}$; $I_{Dq1} = I_{Dq2} = 100\text{ mA}$ (carrier section, driver and final stages); $V_{GS1} = 2.55\text{ V}$ (peaking section, driver stage); $V_{GS2} = 1.47\text{ V}$ (peaking section, final stage); Test signal: 1-C W-CDMA; TM1; 64 DPCH; PAR 9.9dB at 0.01% probability CCDF; in an NXP, f = 2110 MHz to 2170 MHz, Doherty application circuit (see [Figure 3](#) and [Figure 4](#)).

Symbol	Parameter	Conditions	Min	Typ	Max	Unit
P _{L(3dB)}	output power at 3 dB gain compression	f = 2140 MHz	-	46.6	-	W
η _D	drain efficiency	8 dB OBO (P _L = 38.6 dBm); f = 2140 MHz	-	36.5	-	%
G _p	power gain	P _{L(AV)} = 7.25 W; f = 2140 MHz	-	26.1	-	dB
B _{video}	video bandwidth	P _{L(AV)} = 7.25 W; f = 2140 MHz; 2-tone CW	-	145	-	MHz
G _{flat}	gain flatness	P _{L(AV)} = 7.25 W	-	0.2	-	dB
ΔG/ΔT	gain variation with temperature	f = 2140 MHz	[1]	0.03	-	dB/°C
K	Rollett stability factor	T _{case} = -40 °C; f = 0.1 GHz to 3 GHz	[1]	>1	-	

[1] For carrier and peaking sections (S-parameters measured with load-pull jig).

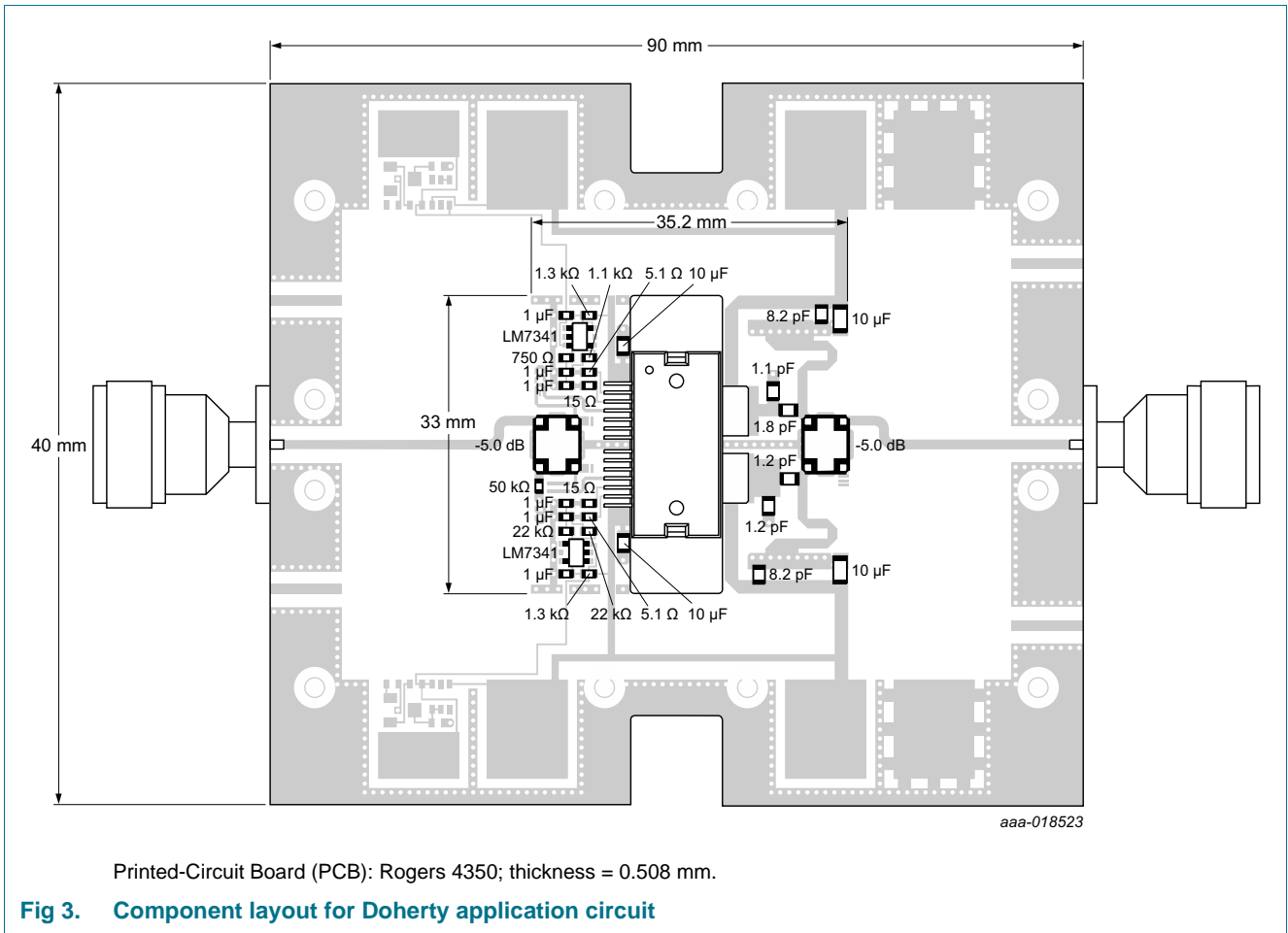

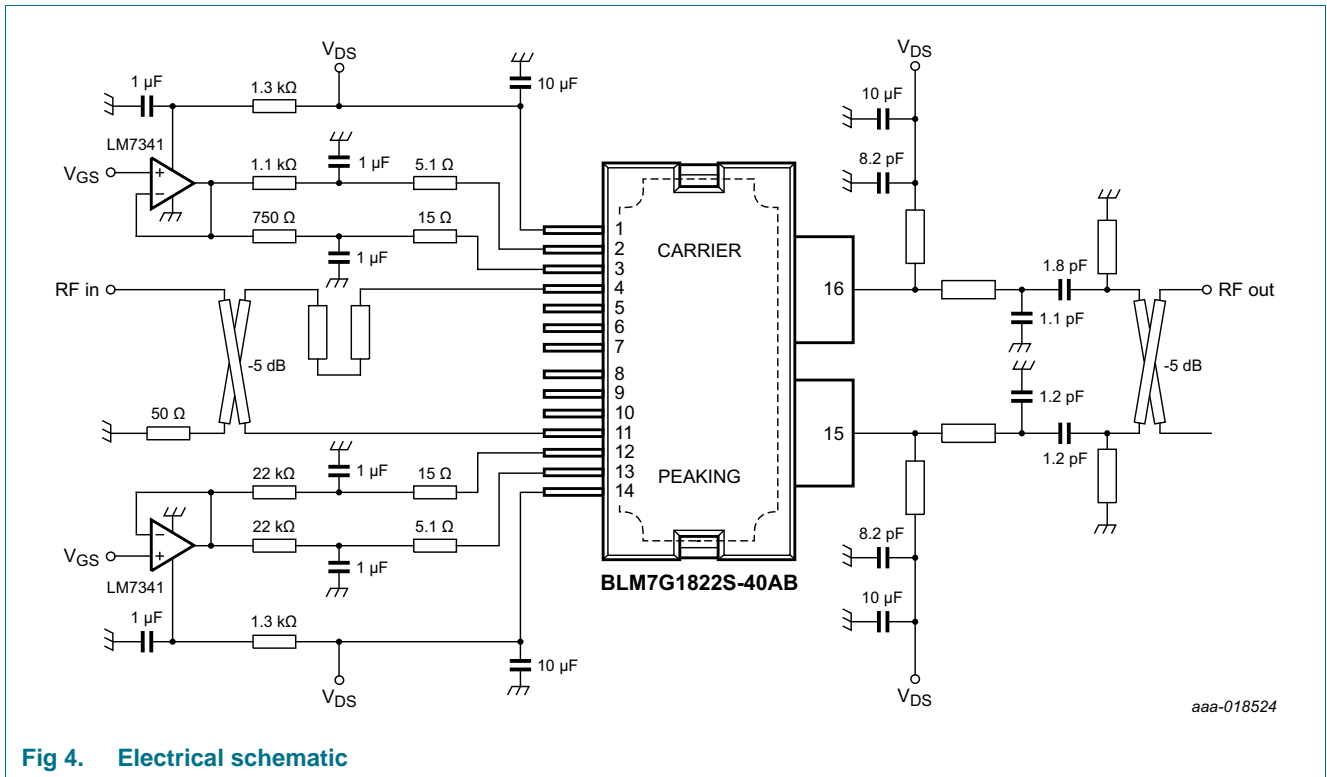

8.1 Possible circuit topologies

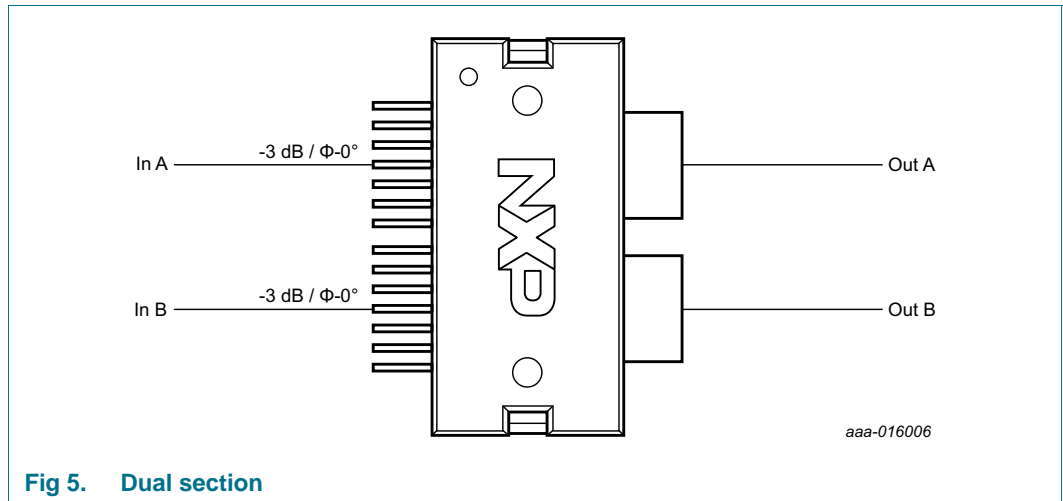

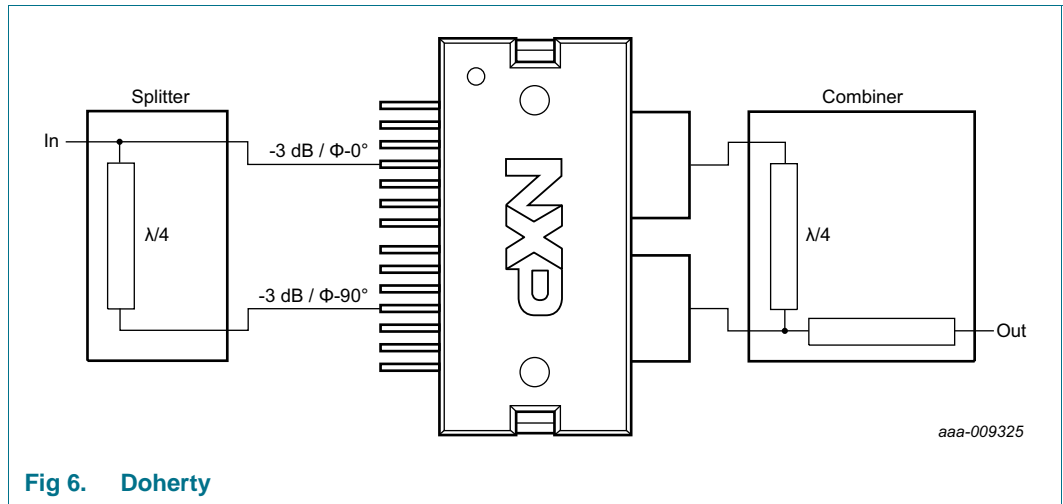

Fig 6. Doherty

8.2 Ruggedness in class-AB operation

The BLM7G1822S-40AB and BLM7G1822S-40ABG are capable of withstanding a load mismatch corresponding to VSWR = 10 : 1 through all phases under the following conditions: $V_{DS} = 32\text{ V}$; $I_{Dq1} = 20\text{ mA}$ and $I_{Dq2} = 75\text{ mA}$ for carrier section; $I_{Dq1} = 40\text{ mA}$ and $I_{Dq2} = 120\text{ mA}$ for peaking section; P_i is corresponding to $P_{L(3dB)}$ under $Z_S = 50\ \Omega$ load; $f = 2140\text{ MHz}$.

8.3 Impedance information

Table 9. Typical impedance tuned for maximum output power

Measured load-pull data at 3 dB gain compression point; test signal: pulsed CW; $T_{case} = 25\text{ }^{\circ}\text{C}$; $V_{DS} = 28\text{ V}$; $I_{Dq1} = 20\text{ mA}$ (carrier section, driver stage); $I_{Dq2} = 65\text{ mA}$ (carrier section, final stage); $I_{Dq1} = 40\text{ mA}$ (peaking section, driver stage); $I_{Dq2} = 130\text{ mA}$ (carrier section, final stage); $t_p = 100\text{ }\mu\text{s}$; $\delta = 10\text{ }\%$; $Z_S = 50\text{ }\Omega$. Typical values unless otherwise specified.

f (MHz)	tuned for maximum output power					tuned for maximum efficiency				
	Z _L (Ω)	G _{p(max)} (dB)	P _L (W)	η_{add} (%)	AM-PM (deg)	Z _L (Ω)	G _{p(max)} (dB)	P _L (W)	η_{add} (%)	AM-PM (deg)
carrier section										
BLM7G1822S-40AB										
1700	15.3 – j14.5	33.2	42.7	50.6	8.3	28.5 – j20.2	34.6	41.6	56.5	9.2
1800	16.3 – j11.7	32.9	42.7	50.8	6.3	31.3 – j8.60	34.1	41.6	57.1	7.0
1900	16.1 – j9.70	32.1	42.8	50.8	6.1	26.5 – j0.01	33.3	41.7	57.3	6.9
2000	15.5 – j8.10	31.5	42.8	50.1	6.1	21.0 + j2.20	32.6	42.0	56.4	7.3
2100	14.4 – j6.90	31.5	42.9	50.0	6.9	15.6 + j2.00	32.9	42.1	55.8	8.6
2200	13.7 – j6.60	31.7	42.7	49.8	8.5	12.3 + j1.20	33.0	41.6	54.3	9.6
2300	12.8 – j6.80	31.4	42.5	49.1	10.6	10.0 + j0.10	32.5	41.3	53.6	10.3
BLM7G1822S-40ABG										
1700	15.8 – j16.1	33.5	42.5	52.9	9.2	28.9 – j21.8	35.1	41.6	57.9	11.1
1800	16.5 – j13.8	32.9	42.5	51.2	7.7	30.6 – j11.6	34.3	41.6	56.8	8.4
1900	16.7 – j12.4	32.2	42.5	50.2	7.2	27.9 – j4.64	33.5	41.7	55.9	7.8
2000	16.3 – j9.74	31.7	42.5	51.2	7.3	20.4 + j0.45	32.7	41.7	55.6	9.0
2100	15.6 – j8.61	31.5	42.6	52.0	9.5	15.9 + j0.68	32.6	41.7	56.4	11.8
2200	14.6 – j8.87	31.3	42.5	49.7	10.3	12.7 – j0.44	32.4	41.6	53.8	12.1
2300	13.4 – j9.32	30.5	42.4	48.2	12.8	10.7 – j1.98	31.7	41.6	53.7	13.2
peaking section										
BLM7G1822S-40AB										
1700	7.02 – j10.1	33.4	45.4	51.2	1.0	13.6 – j11.6	34.7	44.1	56.4	3.9
1800	7.10 – j9.70	33.3	45.5	50.5	0.9	13.4 – j7.20	34.4	44.3	57.2	2.9
1900	6.90 – j10.0	32.6	45.6	48.8	-0.1	11.6 – j5.20	33.6	44.4	56.7	2.2
2000	6.68 – j10.2	32.6	45.6	49.4	-0.5	9.30 – j4.80	33.5	44.5	56.1	2.1
2100	6.52 – j10.2	33.3	45.6	49.3	4.1	7.20 – j5.40	33.9	44.5	54.9	6.4
2200	6.39 – j10.4	33.1	45.4	49.5	7.5	6.20 – j6.30	33.8	44.5	54.6	8.5
2300	5.83 – j10.5	31.5	45.1	50.2	11.2	5.50 – j7.50	32.4	44.4	54.5	12.2
BLM7G1822S-40ABG										
1700	6.43 – j11.5	32.5	45.4	53.9	1.9	13.8 – j13.4	33.9	44.0	61.0	3.2
1800	6.54 – j11.8	32.3	45.4	52.5	1.2	14.5 – j10.0	33.7	44.2	59.4	2.8
1900	6.59 – j12.2	32.3	45.5	51.8	-6	13.0 – j8.07	33.5	44.3	58.9	2.4
2000	6.49 – j12.1	32.5	45.5	51.3	-1.7	9.21 – j7.30	33.6	44.5	57.2	1.2
2100	6.48 – j12.1	32.7	45.6	50.7	3.4	7.36 – j7.91	33.6	44.6	57.1	2.4
2200	6.12 – j12.4	32.6	45.3	51.2	8.2	6.21 – j8.66	33.5	44.4	56.8	7.5
2300	5.78 – j12.4	31.8	45.0	52.0	10.9	5.34 – j9.17	32.5	44.2	56.7	11.5

8.4 Graphs

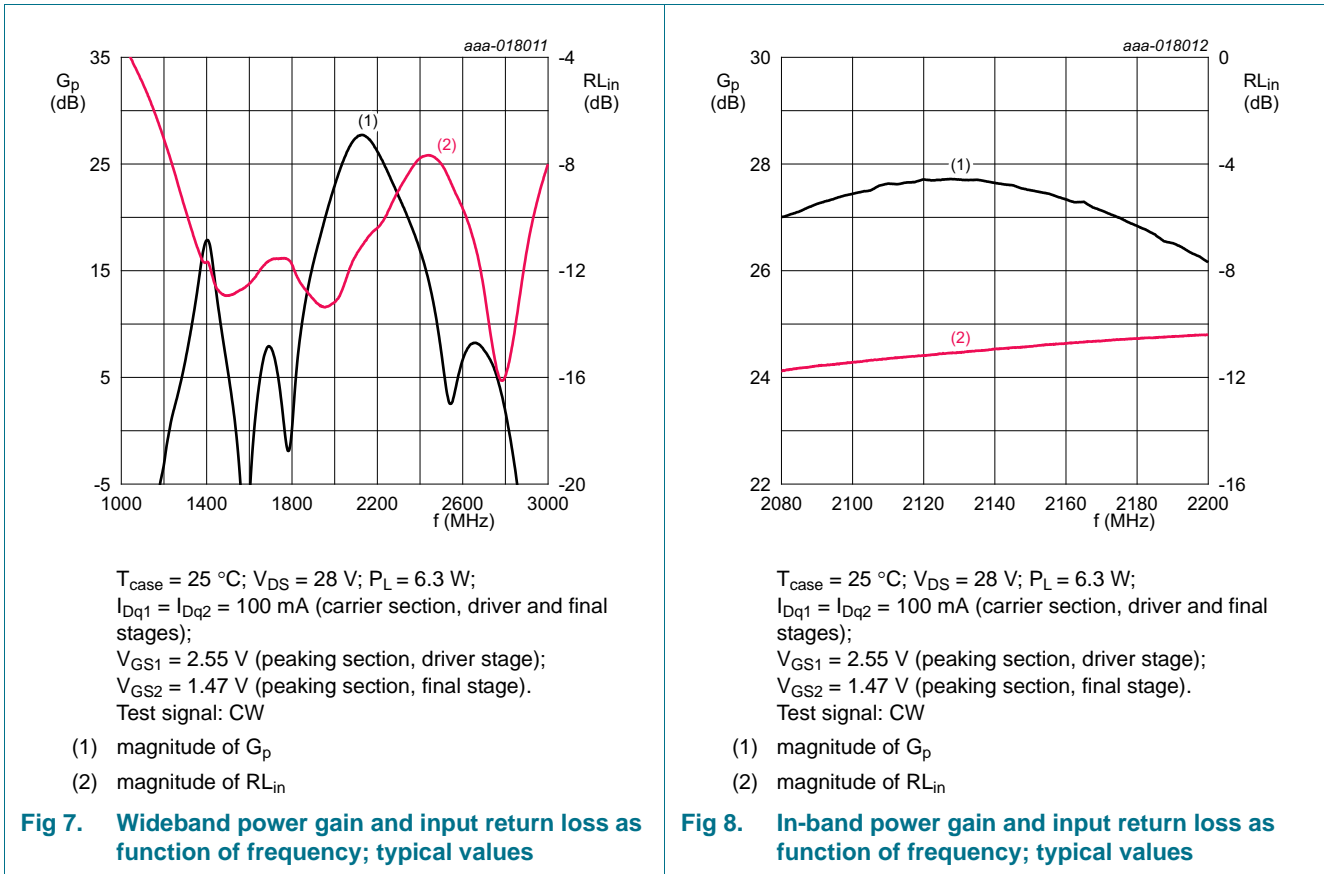

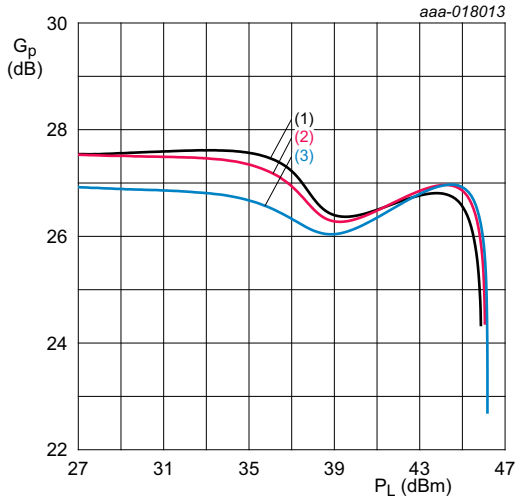

$T_{case} = 25\text{ }^{\circ}\text{C}$; $V_{DS} = 28\text{ V}$; $I_{Dq1} = I_{Dq2} = 100\text{ mA}$ (carrier section, driver and final stages);
 $V_{GS1} = 2.55\text{ V}$ (peaking section, driver stage);
 $V_{GS2} = 1.47\text{ V}$ (peaking section, final stage).
 Test signal: CW

- (1) $f = 2110\text{ MHz}$
- (2) $f = 2140\text{ MHz}$
- (3) $f = 2170\text{ MHz}$

Fig 9. Power gain as a function of output power; typical values

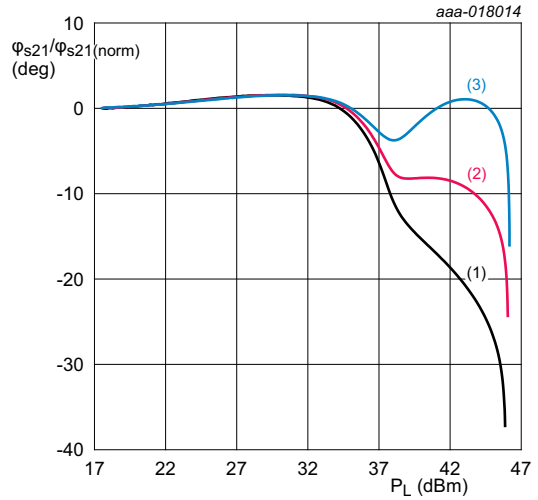

$T_{case} = 25\text{ }^{\circ}\text{C}$; $V_{DS} = 28\text{ V}$; $I_{Dq1} = I_{Dq2} = 100\text{ mA}$ (carrier section, driver and final stages);
 $V_{GS1} = 2.55\text{ V}$ (peaking section, driver stage);
 $V_{GS2} = 1.47\text{ V}$ (peaking section, final stage).
 Test signal: CW

- (1) $f = 2110\text{ MHz}$
- (2) $f = 2140\text{ MHz}$
- (3) $f = 2170\text{ MHz}$

Fig 10. Normalized phase response as a function of output power; typical values

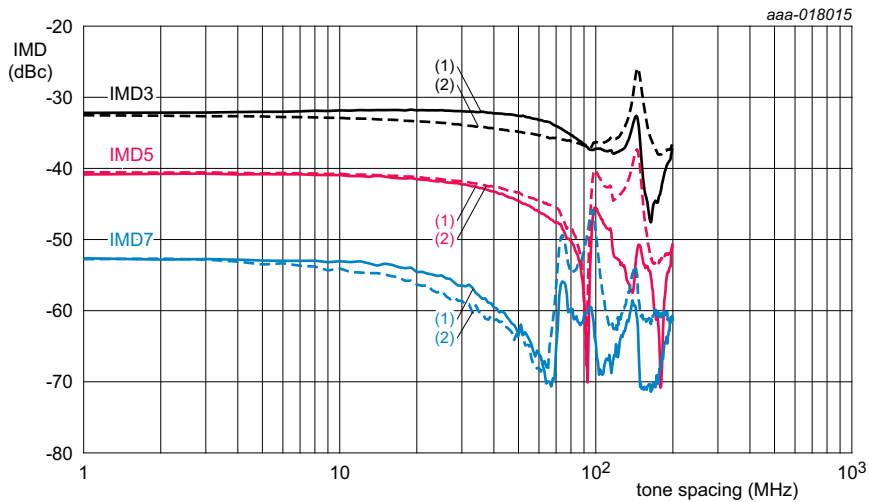

$T_{case} = 25\text{ }^{\circ}\text{C}$; $V_{DS} = 28\text{ V}$; $I_{Dq1} = I_{Dq2} = 100\text{ mA}$ (carrier section, driver and final stages); $V_{GS1} = 2.55\text{ V}$ (peaking section, driver stage); $V_{GS2} = 1.47\text{ V}$ (peaking section, final stage).
 Test signal: 2-tone CW; $f_c = 2140\text{ MHz}$.

- (1) IMD low
- (2) IMD high

Fig 11. Intermodulation distortion as a function of tone spacing; typical values

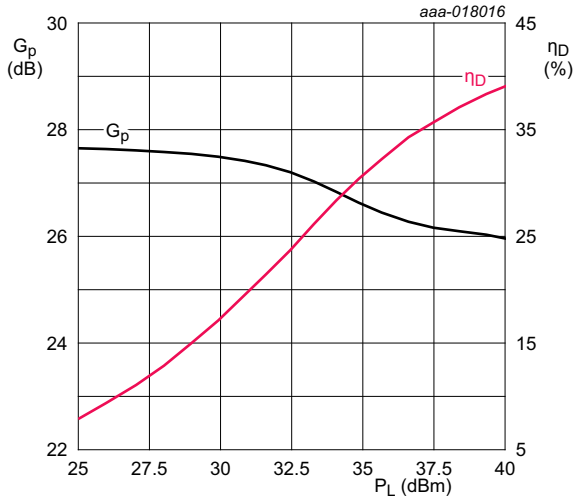

$T_{case} = 25\text{ }^\circ\text{C}$; $V_{DS} = 28\text{ V}$; $I_{Dq1} = I_{Dq2} = 100\text{ mA}$ (carrier section, driver and final stages);
 $V_{GS1} = 2.55\text{ V}$ (peaking section, driver stage);
 $V_{GS2} = 1.47\text{ V}$ (peaking section, final stage).
 Test signal: 1-carrier W-CDMA; test model 1; 64 DPCH;
 PAR 9.9 dB at 0.01% probability CCDF; $f = 2140\text{ MHz}$.

Fig 12. Power gain and drain efficiency as function of output power; typical values

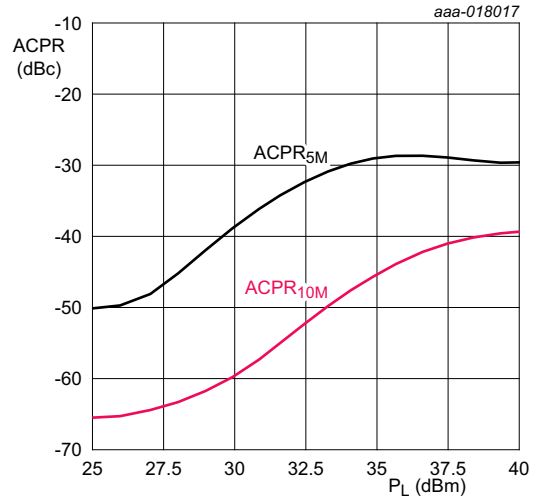

$T_{case} = 25\text{ }^\circ\text{C}$; $V_{DS} = 28\text{ V}$; $I_{Dq1} = I_{Dq2} = 100\text{ mA}$ (carrier section, driver and final stages);
 $V_{GS1} = 2.55\text{ V}$ (peaking section, driver stage);
 $V_{GS2} = 1.47\text{ V}$ (peaking section, final stage).
 Test signal: 1-carrier W-CDMA; test model 1; 64 DPCH;
 PAR 9.9 dB at 0.01% probability CCDF; $f = 2140\text{ MHz}$.

Fig 13. Adjacent channel power ratio as a function of output power; typical values

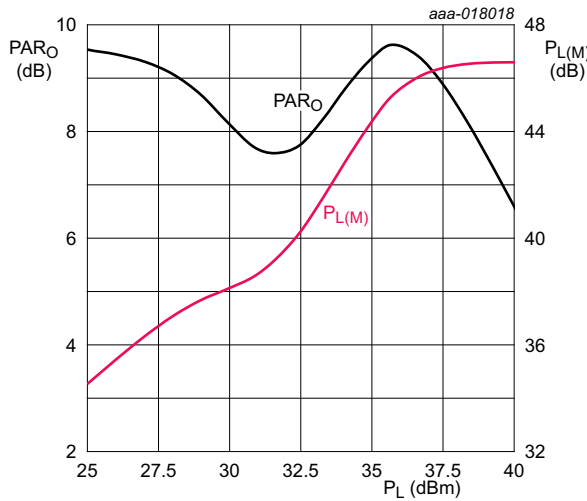

$T_{case} = 25\text{ }^\circ\text{C}$; $V_{DS} = 28\text{ V}$; $I_{Dq1} = I_{Dq2} = 100\text{ mA}$ (carrier section, driver and final stages); $V_{GS1} = 2.55\text{ V}$ (peaking section, driver stage); $V_{GS2} = 1.47\text{ V}$ (peaking section, final stage).
 Test signal: 1-carrier W-CDMA; test model 1; 64 DPCH; PAR 9.9 dB at 0.01% probability CCDF; $f = 2140\text{ MHz}$.

Fig 14. Output peak-to-average ratio and peak output power as function of output power; typical values

9. Package outline

HSOP16F: plastic, heatsink small outline package; 16 leads(flat)

SOT1211-2

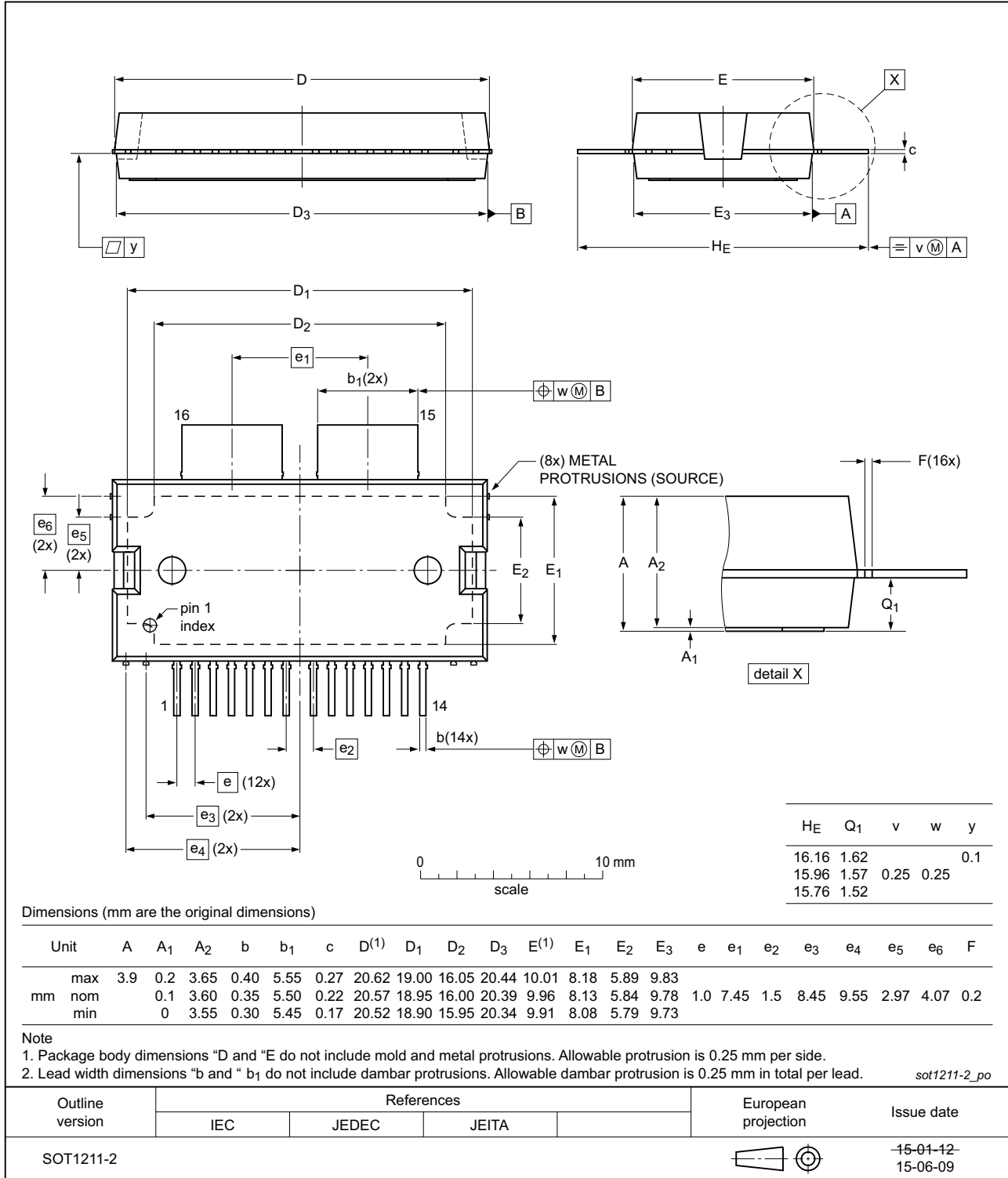

Fig 15. Package outline SOT1211-2 (HSOP16F)

HSOP16: plastic, heatsink small outline package; 16 leads

SOT1212-2

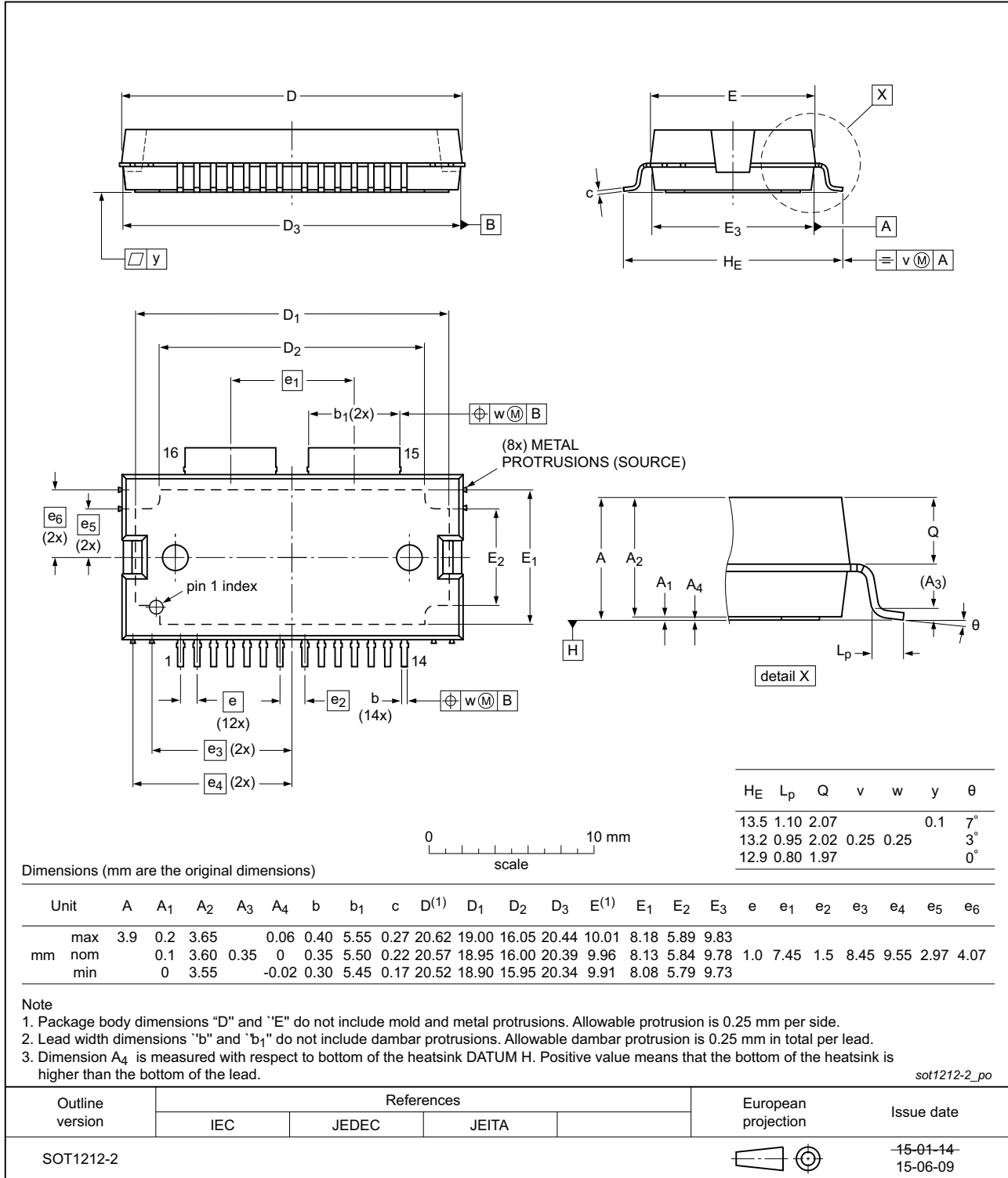

Fig 16. Package outline SOT1212-2 (HSOP16)

10. Handling information

CAUTION



This device is sensitive to ElectroStatic Discharge (ESD). Observe precautions for handling electrostatic sensitive devices.

Such precautions are described in the *ANSI/ESD S20.20*, *IEC/ST 61340-5*, *JESD625-A* or equivalent standards.

11. Abbreviations

Table 10. Abbreviations

Acronym	Description
AM	Amplitude Modulation
3GPP	3rd Generation Partnership Project
CCDF	Complementary Cumulative Distribution Function
CW	Continuous Wave
DPCH	Dedicated Physical CHannel
ESD	ElectroStatic Discharge
GEN7	Seventh Generation
LDMOS	Laterally Diffused Metal Oxide Semiconductor
MMIC	Monolithic Microwave Integrated Circuit
MTF	Median Time to Failure
OBO	Output Back Off
PAR	Peak-to-Average Ratio
PM	Phase Modulation
VSWR	Voltage Standing-Wave Ratio
W-CDMA	Wideband Code Division Multiple Access

12. Revision history

Table 11. Revision history

Document ID	Release date	Data sheet status	Change notice	Supersedes
BLM7G1822S-40AB_S-40ABG v.1	20150710	Product data sheet	-	-

13. Legal information

13.1 Data sheet status

Document status ^{[1][2]}	Product status ^[3]	Definition
Objective [short] data sheet	Development	This document contains data from the objective specification for product development.
Preliminary [short] data sheet	Qualification	This document contains data from the preliminary specification.
Product [short] data sheet	Production	This document contains the product specification.

[1] Please consult the most recently issued document before initiating or completing a design.

[2] The term 'short data sheet' is explained in section "Definitions".

[3] The product status of device(s) described in this document may have changed since this document was published and may differ in case of multiple devices. The latest product status information is available on the Internet at URL <http://www.nxp.com>.

13.2 Definitions

Draft — The document is a draft version only. The content is still under internal review and subject to formal approval, which may result in modifications or additions. NXP Semiconductors does not give any representations or warranties as to the accuracy or completeness of information included herein and shall have no liability for the consequences of use of such information.

Short data sheet — A short data sheet is an extract from a full data sheet with the same product type number(s) and title. A short data sheet is intended for quick reference only and should not be relied upon to contain detailed and full information. For detailed and full information see the relevant full data sheet, which is available on request via the local NXP Semiconductors sales office. In case of any inconsistency or conflict with the short data sheet, the full data sheet shall prevail.

Product specification — The information and data provided in a Product data sheet shall define the specification of the product as agreed between NXP Semiconductors and its customer, unless NXP Semiconductors and customer have explicitly agreed otherwise in writing. In no event however, shall an agreement be valid in which the NXP Semiconductors product is deemed to offer functions and qualities beyond those described in the Product data sheet.

13.3 Disclaimers

Limited warranty and liability — Information in this document is believed to be accurate and reliable. However, NXP Semiconductors does not give any representations or warranties, expressed or implied, as to the accuracy or completeness of such information and shall have no liability for the consequences of use of such information. NXP Semiconductors takes no responsibility for the content in this document if provided by an information source outside of NXP Semiconductors.

In no event shall NXP Semiconductors be liable for any indirect, incidental, punitive, special or consequential damages (including - without limitation - lost profits, lost savings, business interruption, costs related to the removal or replacement of any products or rework charges) whether or not such damages are based on tort (including negligence), warranty, breach of contract or any other legal theory.

Notwithstanding any damages that customer might incur for any reason whatsoever, NXP Semiconductors' aggregate and cumulative liability towards customer for the products described herein shall be limited in accordance with the *Terms and conditions of commercial sale* of NXP Semiconductors.

Right to make changes — NXP Semiconductors reserves the right to make changes to information published in this document, including without limitation specifications and product descriptions, at any time and without notice. This document supersedes and replaces all information supplied prior to the publication hereof.

Suitability for use — NXP Semiconductors products are not designed, authorized or warranted to be suitable for use in life support, life-critical or safety-critical systems or equipment, nor in applications where failure or malfunction of an NXP Semiconductors product can reasonably be expected to result in personal injury, death or severe property or environmental damage. NXP Semiconductors and its suppliers accept no liability for inclusion and/or use of NXP Semiconductors products in such equipment or applications and therefore such inclusion and/or use is at the customer's own risk.

Applications — Applications that are described herein for any of these products are for illustrative purposes only. NXP Semiconductors makes no representation or warranty that such applications will be suitable for the specified use without further testing or modification.

Customers are responsible for the design and operation of their applications and products using NXP Semiconductors products, and NXP Semiconductors accepts no liability for any assistance with applications or customer product design. It is customer's sole responsibility to determine whether the NXP Semiconductors product is suitable and fit for the customer's applications and products planned, as well as for the planned application and use of customer's third party customer(s). Customers should provide appropriate design and operating safeguards to minimize the risks associated with their applications and products.

NXP Semiconductors does not accept any liability related to any default, damage, costs or problem which is based on any weakness or default in the customer's applications or products, or the application or use by customer's third party customer(s). Customer is responsible for doing all necessary testing for the customer's applications and products using NXP Semiconductors products in order to avoid a default of the applications and the products or of the application or use by customer's third party customer(s). NXP does not accept any liability in this respect.

Limiting values — Stress above one or more limiting values (as defined in the Absolute Maximum Ratings System of IEC 60134) will cause permanent damage to the device. Limiting values are stress ratings only and (proper) operation of the device at these or any other conditions above those given in the Recommended operating conditions section (if present) or the Characteristics sections of this document is not warranted. Constant or repeated exposure to limiting values will permanently and irreversibly affect the quality and reliability of the device.

Terms and conditions of commercial sale — NXP Semiconductors products are sold subject to the general terms and conditions of commercial sale, as published at <http://www.nxp.com/profile/terms>, unless otherwise agreed in a valid written individual agreement. In case an individual agreement is concluded only the terms and conditions of the respective agreement shall apply. NXP Semiconductors hereby expressly objects to applying the customer's general terms and conditions with regard to the purchase of NXP Semiconductors products by customer.

No offer to sell or license — Nothing in this document may be interpreted or construed as an offer to sell products that is open for acceptance or the grant, conveyance or implication of any license under any copyrights, patents or other industrial or intellectual property rights.

Export control — This document as well as the item(s) described herein may be subject to export control regulations. Export might require a prior authorization from competent authorities.

Non-automotive qualified products — Unless this data sheet expressly states that this specific NXP Semiconductors product is automotive qualified, the product is not suitable for automotive use. It is neither qualified nor tested in accordance with automotive testing or application requirements. NXP Semiconductors accepts no liability for inclusion and/or use of non-automotive qualified products in automotive equipment or applications.

In the event that customer uses the product for design-in and use in automotive applications to automotive specifications and standards, customer (a) shall use the product without NXP Semiconductors' warranty of the product for such automotive applications, use and specifications, and (b) whenever customer uses the product for automotive applications beyond

NXP Semiconductors' specifications such use shall be solely at customer's own risk, and (c) customer fully indemnifies NXP Semiconductors for any liability, damages or failed product claims resulting from customer design and use of the product for automotive applications beyond NXP Semiconductors' standard warranty and NXP Semiconductors' product specifications.

Translations — A non-English (translated) version of a document is for reference only. The English version shall prevail in case of any discrepancy between the translated and English versions.

13.4 Trademarks

Notice: All referenced brands, product names, service names and trademarks are the property of their respective owners.

14. Contact information

For more information, please visit: <http://www.nxp.com>

For sales office addresses, please send an email to: salesaddresses@nxp.com

15. Contents

1	Product profile	1
1.1	General description	1
1.2	Features and benefits	1
1.3	Applications	1
2	Pinning information	2
2.1	Pinning	2
2.2	Pin description	2
3	Ordering information	3
4	Block diagram	3
5	Limiting values	3
6	Thermal characteristics	4
7	Characteristics	4
8	Application information	6
8.1	Possible circuit topologies	8
8.2	Ruggedness in class-AB operation	9
8.3	Impedance information	10
8.4	Graphs	11
9	Package outline	14
10	Handling information	16
11	Abbreviations	16
12	Revision history	16
13	Legal information	17
13.1	Data sheet status	17
13.2	Definitions	17
13.3	Disclaimers	17
13.4	Trademarks	18
14	Contact information	18
15	Contents	19

Please be aware that important notices concerning this document and the product(s) described herein, have been included in section 'Legal information'.

© NXP Semiconductors N.V. 2015.

All rights reserved.

For more information, please visit: <http://www.nxp.com>

For sales office addresses, please send an email to: salesaddresses@nxp.com

Date of release: 10 July 2015

Document identifier: BLM7G1822S-40AB_S-40ABG