

**Single Phase Full-wave Motor Driver for Silent Fan Motor****AM9789****General Description**

The AM9789 is a single-phase, full wave motor driver suited for DC fan motor, and its speed is controlled by PWM input signal. It is suitable for both game machine and CPU cooler which need silent drivers. It features lock protection, thermal shutdown, PWM control, low noise and so on.

The AM9789 is available in MSOP-8, MSOP-10, DFN-3×3-8 and DFN-3×3-10 packages.

**Features**

- BTL Output Single-phase Full-wave Linear Driver
- Silent Driver
- Low Supply Current (Normal Operation, Less than 4mA)
- Low Standby Current (PWM=0 Duty) @ Supply Current Less than 200 $\mu$ A
- Speed Controllable by PWM Input Signal
- Built-in Quick Start Function
- Built-in Lock Protection and Auto Restart Function
- Built-in Hall Bias Circuit
- Built-in FG Output
- Built-in Thermal Shutdown Circuit
- Built-in Over Current Protection Circuit

**Applications**

- Silent Fan Motors

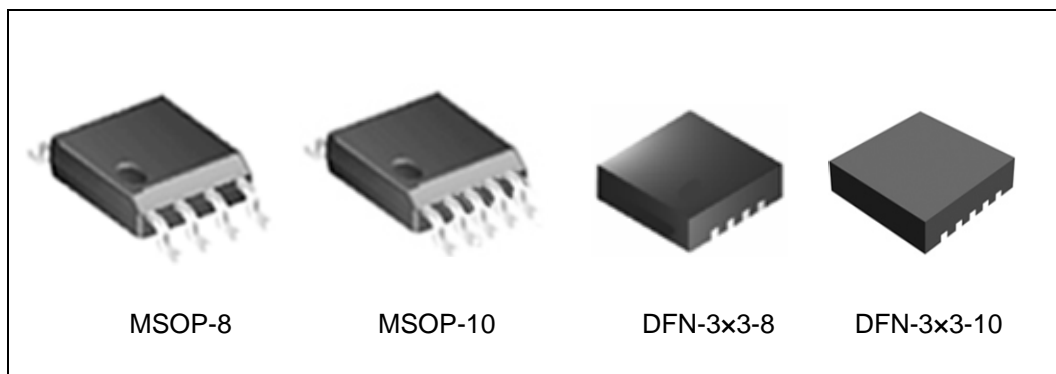

Figure 1. Package Types of AM9789

**Single Phase Full-wave Motor Driver for Silent Fan Motor**
**AM9789**
**Pin Configuration**

Figure 2. Pin Configuration of AM9789 (Top View)

**Pin Description**

Pin Number		Pin Name	Function
MSOP-10/ DFN-3x3-10	MSOP-8/ DFN-3x3-8		
1	1	OUT2	Output Connection 2
2		NC	No connected
3	3	HIN+	Hall input(+). Connect to Hall element positive output
4		HB	Hall bias
5	4	HIN-	Hall input(-). Connect to Hall element negative output
6	5	FG	Rotation speed output
7	6	PWM	PWM signal input terminal
8	2	VCC	Power supply
9	7	OUT1	Output Connection 1
10	8	GND	Ground

Functional Block Diagram

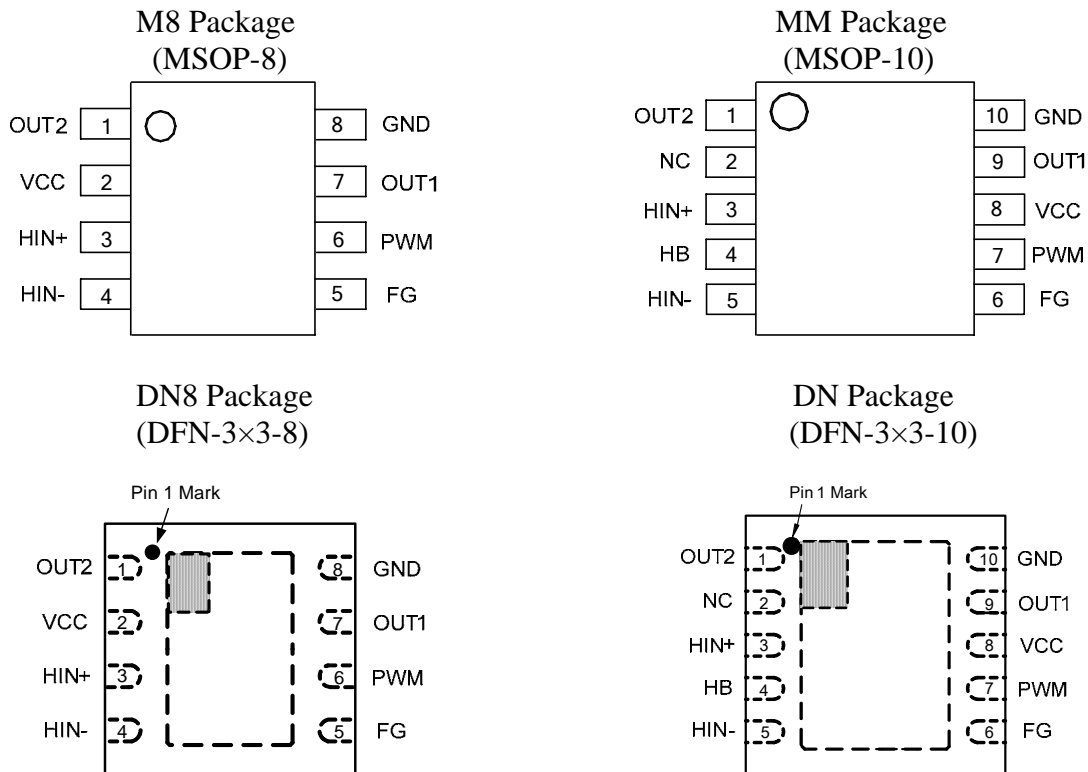
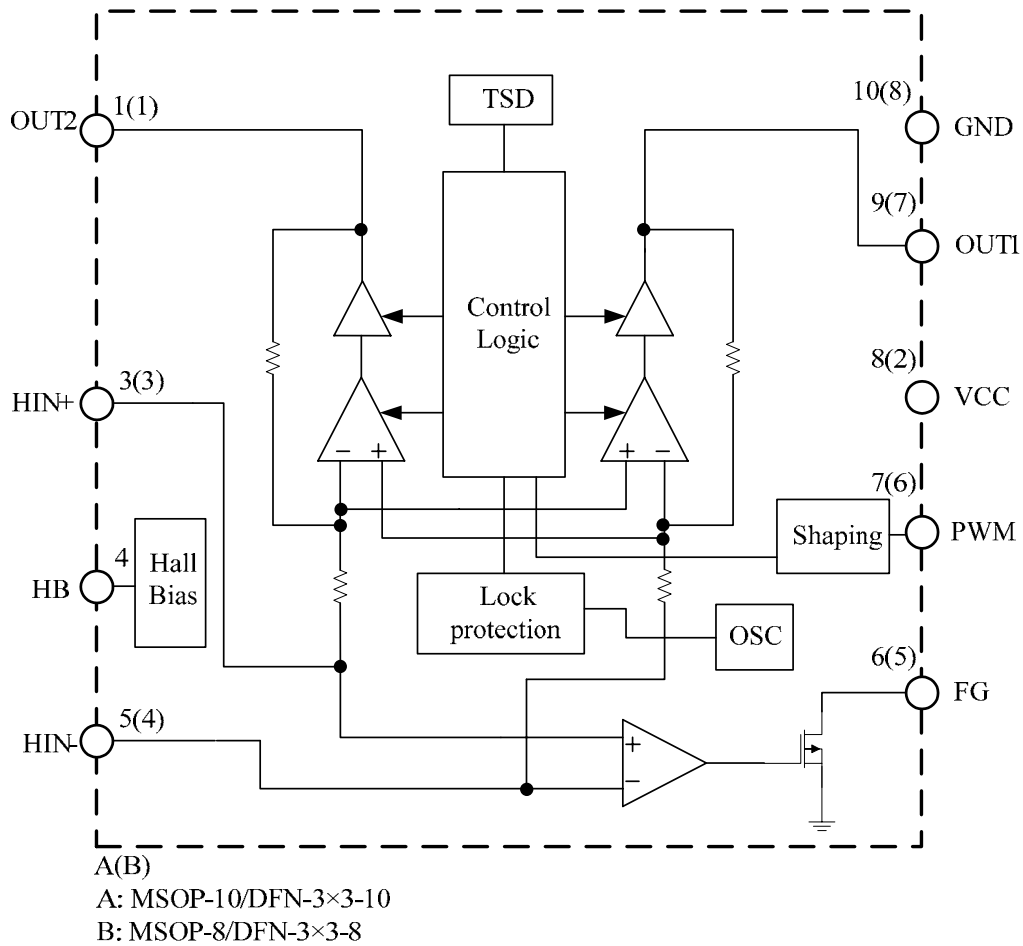
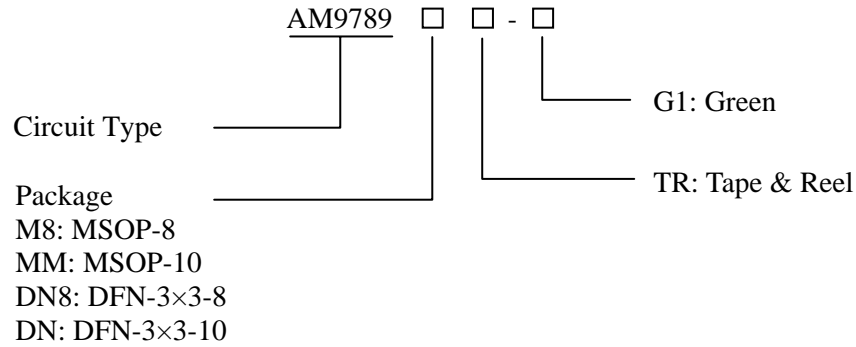

Figure 3. Functional Block Diagram of AM9789

**Single Phase Full-wave Motor Driver for Silent Fan Motor**

**AM9789**

**Ordering Information**



Package	Temperature Range	Part Number	Marking ID	Packing Type
MSOP-10	-40 to 105°C	AM9789MMTR-G1	9789MM-G1	Tape & Reel
MSOP-8		AM9789M8TR-G1	9789M8-G1	Tape & Reel
DFN-3×3-8		AM9789DN8TR-G1	B6E	Tape & Reel
DFN-3×3-10		AM9789DNTR-G1	BFD	Tape & Reel

BCD Semiconductor's Pb-free products, as designated with "G1" suffix in the part number, are RoHS compliant and green.

**Single Phase Full-wave Motor Driver for Silent Fan Motor****AM9789****Absolute Maximum Ratings (T<sub>A</sub>=25°C, Note 1)**

Parameter	Symbol	Value		Unit
Supply Voltage	V <sub>CC</sub>	10		V
Output Current	I <sub>OUT</sub>	1		A
Output Voltage	V <sub>OUT</sub>	10		V
HB Output Current	I <sub>HB</sub>	10		mA
FG Output Voltage	V <sub>FG</sub>	10		V
FG Output Sink Current	I <sub>FG</sub>	10		mA
Operation Temperature	T <sub>OP</sub>	-40 to 125		°C
Storage Temperature Range	T <sub>STG</sub>	-55 to 150		°C
Lead Temperature (Soldering 10s)	T <sub>LEAD</sub>	260		°C
Thermal Resistance (Junction to Ambient)	θ <sub>JA</sub>	MSOP-8	205	°C/W
		MSOP-10	195	
		DFN-3x3-8	71	
		DFN-3x3-10	71	
Thermal Resistance (Junction to Case)	θ <sub>JC</sub>	MSOP-8	48	°C/W
		MSOP-10	46	
		DFN-3x3-8	48	
		DFN-3x3-10	48	
Power Dissipation	P <sub>D</sub>	MSOP-8	585	mW
		MSOP-10	585	
		DFN-3x3-8	1760	
		DFN-3x3-10	1760	
ESD (Human Body Model)		4000		V
ESD (Machine Model)		400		V

Note 1: Stresses greater than those listed under “Absolute Maximum Ratings” may cause permanent damage to the device. These are stress ratings only, and functional operation of the device at these or any other conditions beyond those indicated under “Recommended Operating Conditions” is not implied. Exposure to “Absolute Maximum Ratings” for extended periods may affect device reliability.

**Recommended Operating Conditions (T<sub>A</sub>=25°C)**

Parameter	Symbol	Min	Max	Unit
Supply Voltage	V <sub>CC</sub>	2	6	V
Hall Input Voltage Range	V <sub>HB</sub>	0.4	V <sub>CC</sub> -1.1	V
Operating Ambient Temperature	T <sub>A</sub>	-40	105	°C

**Single Phase Full-wave Motor Driver for Silent Fan Motor****AM9789****Electrical Characteristics** $V_{CC}=5V$ ,  $T_A=25^{\circ}C$ , unless otherwise specified.

Parameter	Symbol	Conditions	Min	Typ	Max	Unit
Operation Current	$I_{CC1}$	Rotation Mode		2	4	mA
Standby Current	$I_{CC2}$	$V_{PWM}=0$		130	200	$\mu A$
HB Pin Output Voltage	$V_{HB}$	$I_{HB}=5mA$	1.1	1.3	1.5	V
Lock Detection ON Time	$t_{ON}$		0.3	0.4	0.5	s
Lock Detection OFF Time	$t_{OFF}$		3	4	5	s
Quick Start Enable Time	$t_{QS}$			55	75	ms
Output Drivers Saturation Voltage	$V_{SAT(H+L)}$	$I_{OUT}=250mA$ , upper and lower total		0.5	0.7	V
Input-Output Gain	$G_{IO}$	$V_{OUT}/(V_{HIN+}-V_{HIN-})$	44	47	50	dB
FG Pin Low Voltage	$V_{FG}$	$I_{FG}=5mA$		0.2	0.3	V
FG Pin Leakage Current	$I_{FGL}$	$V_{FG}=5V$		0.1	1	$\mu A$
PWM Input High Level Voltage	$V_{PWMH}$		$0.5 \times V_{CC}$		$V_{CC}$	V
PWM Input Low Level Voltage	$V_{PWML}$		0		$0.2 \times V_{CC}$	V
PWM Input Frequency	$f_{PWM}$		0.02		50	kHz
Hall Input Offset Voltage	$V_{HOFS}$				$\pm 10$	mV
Hall Input Hysteresis Voltage	$V_{HYS}$		$\pm 5$	$\pm 10$	$\pm 15$	mV
Thermal Protection Temperature	$T_{SD}$			165		$^{\circ}C$
Thermal Hysteresis Width	$\Delta T_{SD}$			30		$^{\circ}C$

Typical Performance Characteristics

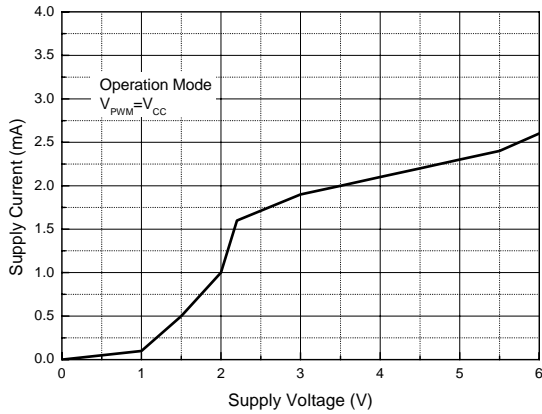

Figure 4. Supply Current vs. Supply Voltage ( $V_{PWM}=V_{CC}$ )

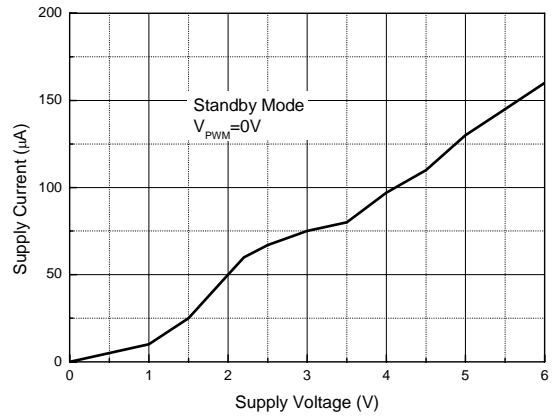

Figure 5. Supply Current vs. Supply Voltage ( $V_{PWM}=0V$ )

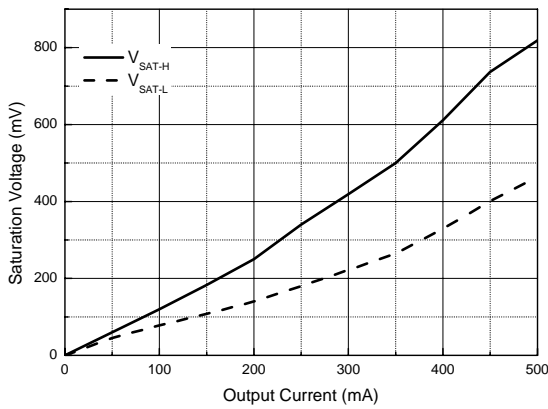

Figure 6. Saturation Voltage vs. Output Current

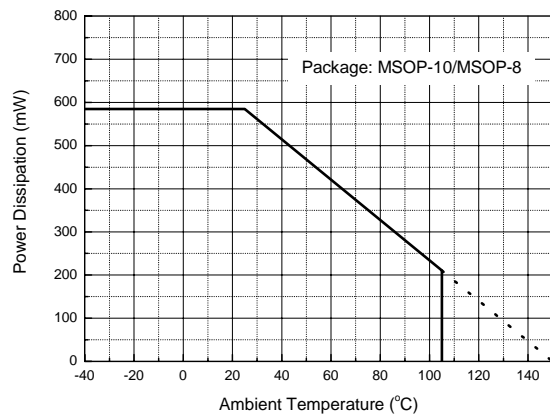

Figure 7. Power Dissipation vs. Temperature (MSOP)

**Typical Performance Characteristics (Continued)**

Figure 8. Power Dissipation vs. Temperature (DFN)



**Single Phase Full-wave Motor Driver for Silent Fan Motor****AM9789****Truth Table**

INPUT			OUTPUT			Mode
HIN-	HIN+	PWM	OUT1	OUT2	FG	
L	H	H	H	L	L	Operation Mode
H	L		L	L	H	
H	L	L	L	L	OFF	
L	H		L	L	L	
L	H	-	L	L	OFF	Lock Mode
H	L		L	L	OFF	
-	-	L	OFF	OFF	OFF	Standby Mode

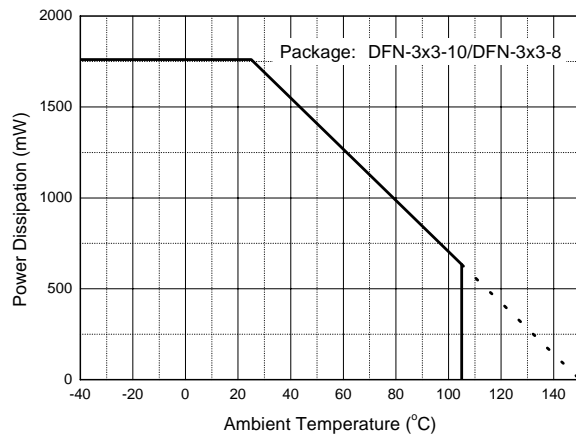
**Typical Application**

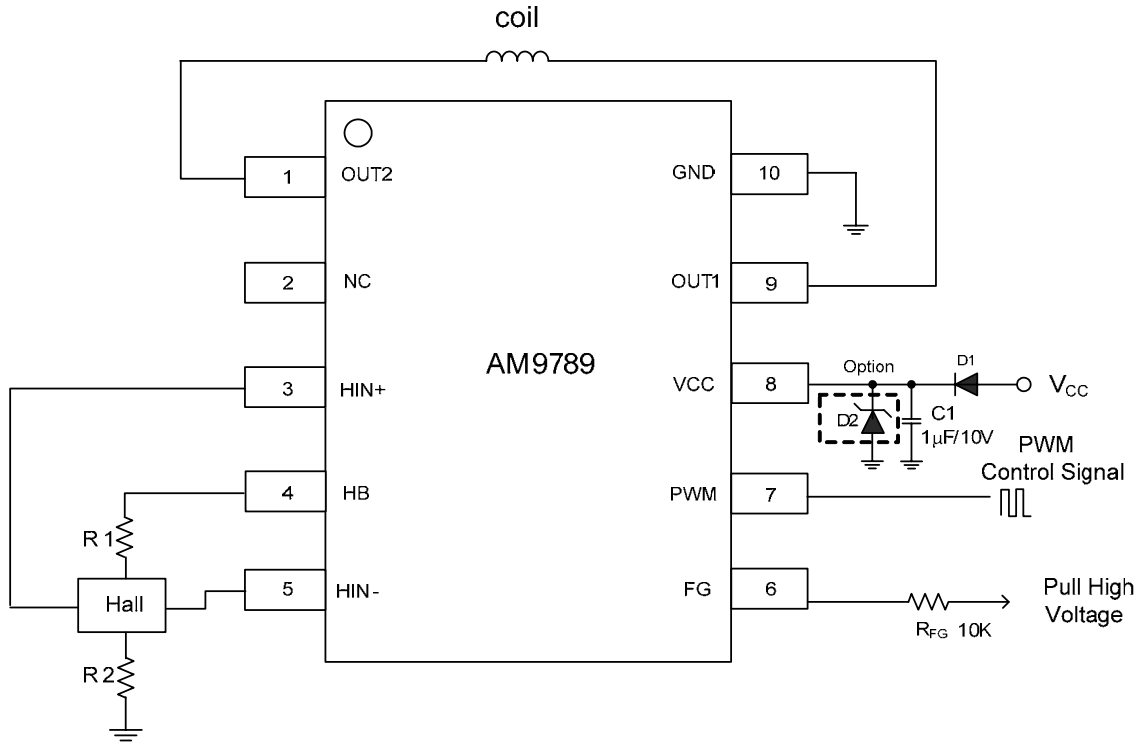

For MSOP-10 package

**Typical Application (Continued)**

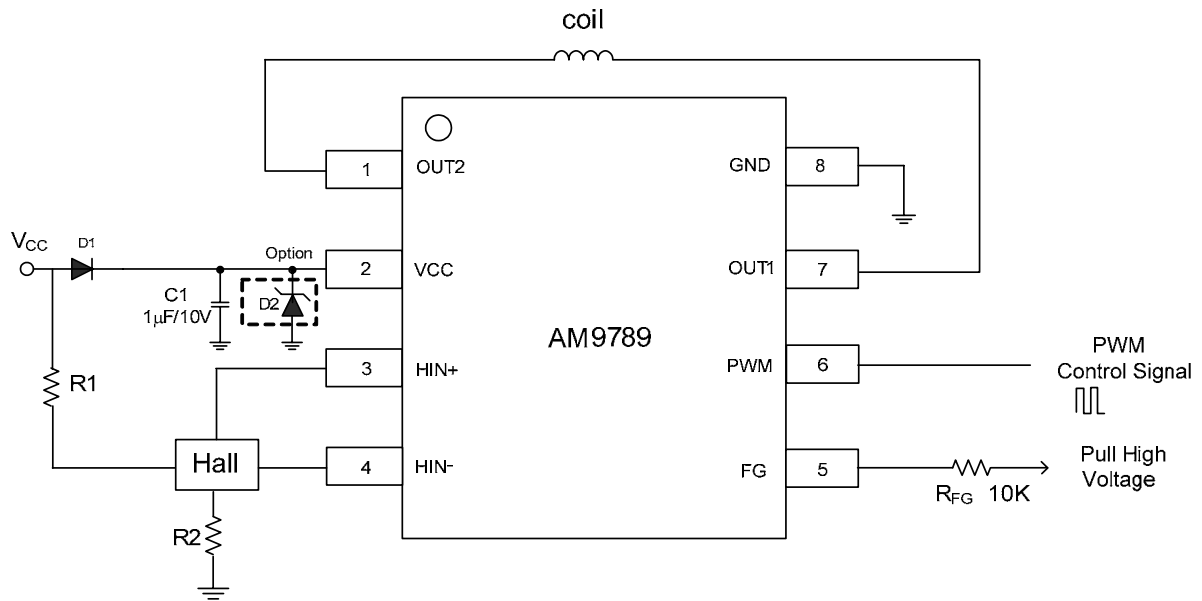

For MSOP-8 package

Figure 9. Typical Applications of AM9789 (Note 2)

Note 2:

D1 is an ordinary diode used to filter the noise from VCC and protect IC if VCC and GND are plugged reversed. C1=1µF/10V typical.

R1 and R2 should be fine tuned based on system design. They can be removed according to the system requirements.

Zener diode (D2) is an optional choice.

R<sub>FG</sub>=10kΩ typical.

**Single Phase Full-wave Motor Driver for Silent Fan Motor**

**AM9789**

**Application Information**

**1. Reverse Connection of Power Supply Connector**

Reverse connection of power supply connector may break IC. Some methods such as inserting a diode between power supply and VCC terminal can be taken to avoid the reverse connection destruction.

**2. Power Supply Line**

Back electromotive force (EMF) causes regenerated current to the power supply line, so insert a capacitor (recommended value: 1μF or larger) as close as possible to the space between the power supply pin (VCC pin) and ground pin (GND pin) for routing regenerated current.

**3. GND Potential and External Components**

Ensure that the potential of GND terminal is the minimum potential in any operating condition. External components connected to the ground must be connected with lines that are as short as possible and external components connected between IC pins must be placed as close to the pins as possible.

**4. Mounting Failures**

In the process of attaching IC to the printed board, more attention must be paid to the direction and location of the IC, since mounting failures may also break IC. In addition, destruction is also possible when the circuit is shorted by foreign substance between outputs or between output and power supply or between output and GND.

**5. Thermal Consideration**

Refer to Figure 7 “Power Dissipation vs. Ambient Temperature (MSOP-10/MSOP-8)”, the IC is safe to operate below the curve and the thermal protection will be caused if the operating area is above the line. For example, when  $T_A=75^{\circ}\text{C}$ , the maximum power dissipation is about 0.35W.

The power dissipation can be calculated by the following equation:

$$P_D = V_{SAT(H+L)} \times I_{OUT} + V_{CC} \times I_{CC}$$

For example,  $V_{CC}=5\text{V}$ ,  $I_{CC}=2\text{mA}$ ,  $I_{OUT}=250\text{mA}$ ,  $V_{SAT(H+L)}=0.5\text{V}$ , then  $P_D=0.135\text{W}$ .

The GND pin provides an electrical connection to the ground and channeling heat away. The printed circuit board (PCB) forms a heat sink and dissipates most of

the heat to the ambient air.

**6. Thermal Shutdown Circuit**

Considering the power dissipation under actual operating condition, the thermal design must be applied with sufficient margin.

AM9789 features thermal shutdown (TSD) circuit (operation temperature is  $165^{\circ}\text{C}$  typical and hysteresis width is  $30^{\circ}\text{C}$  typical). When the chip temperature reaches the TSD circuit temperature, the output terminal becomes an open state. TSD circuit is designed simply for the purpose of intercepting IC from overheating. Make sure that the IC should not be used again after this circuit operating. Figure 10 shows a fan rotates normally first and then enters into OTP mode since the chip temperature reaches  $165^{\circ}\text{C}$ . Finally the chip temperature decreases below  $135^{\circ}\text{C}$ , then OTP mode is canceled and the fan rotates normally again.

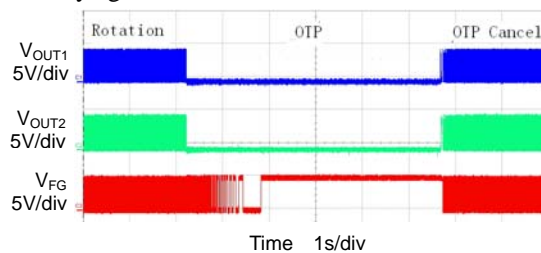

Figure 10. OTP Function

**7. Over Current Protection**

The driver current is detected by AM9789 internal circuit. When the output current is over 1A or larger, AM9789 will close the output driver. After that if the output current decreases, AM9789 will enable the fan to rotate again. Figure 11 shows the detailed process.

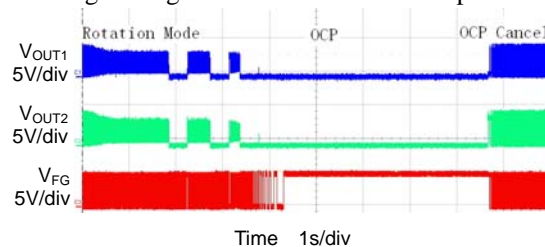

Figure 11. OCP Function

**8. PWM Mode**

The output transistor is on when a high-level voltage is input to the PWM pin, and is off when a low-level voltage is input. PWM controls the speed of the motor by inputting the pulse in accordance with the duty cycle to the PWM pin. When the motor is

### Application Information (Continued)

operated with the PWM pin open, the built-in resistor enables the PWM pin to change to high-level voltage and the motor speed rises to full speed. When the PWM pin is fixed at low-level voltage, the motor decelerates, and after the motor stops, it enters “Power Saving Mode”. Figure 12 shows a rotating fan’s waveform at PWM Mode. Figure 13 shows Lock Mode Waveform at PWM input condition in the same fan.

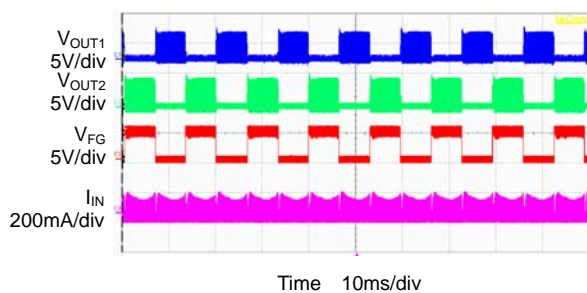

Figure 12. PWM Mode Waveform (PWM: 50% duty cycle,  $V_H=5V$ ,  $V_L=0V$ )

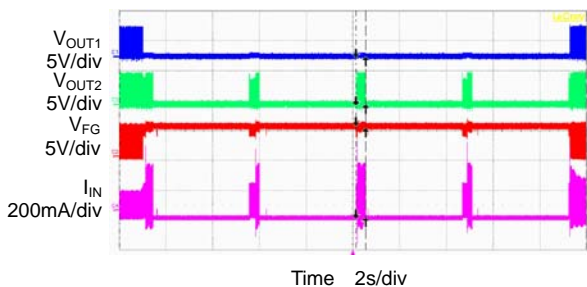

Figure 13. Lock Mode at PWM Input Condition (PWM: 50% duty cycle,  $V_H=5V$ ,  $V_L=0V$ )

### 9. Frequency Generator Function

The FG pin is an open collector output, connecting a pull-up resistor to a high level voltage for the frequency generator function. During the lock mode, FG pin output will be always high. Open the terminal when not in use. Figure 14 shows how this function works.

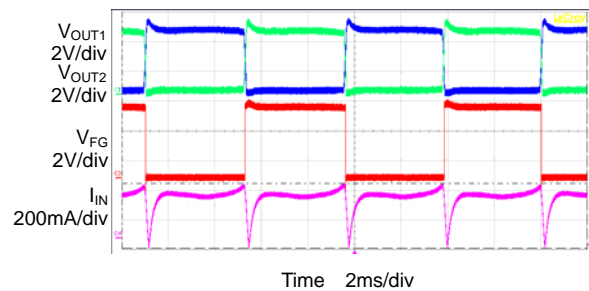

Figure 14. Rotation Mode Waveform

### 10. Lock Protection and Auto-restart

The IC detects the rotation of the motor by Hall signal and the lock detection ON time ( $t_{ON}$ ) and OFF time ( $t_{OFF}$ ) are adjusted by the internal counter. As showed below.

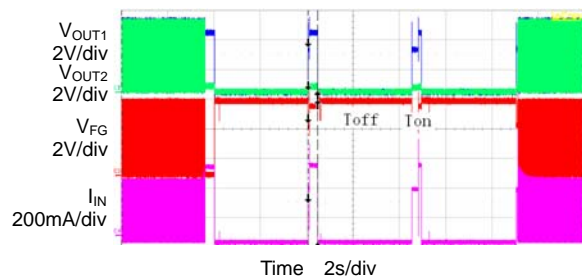

Figure 15. Lock Mode Waveform

### 11. Quick Start and Standby Mode

The IC will enter standby mode when PWM input keeps low level for more than 55ms (typ.). In standby mode, shutdown amplifier and FG will be shutdown, and the supply current is around 130 $\mu$ A. In standby mode, the lock protection function doesn’t work; the fan will restart when released from standby mode. Figure 16 describes this function.

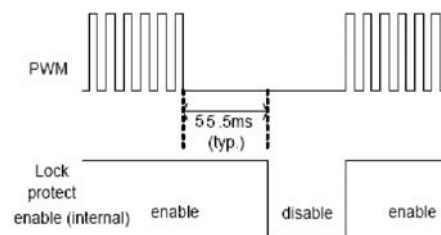
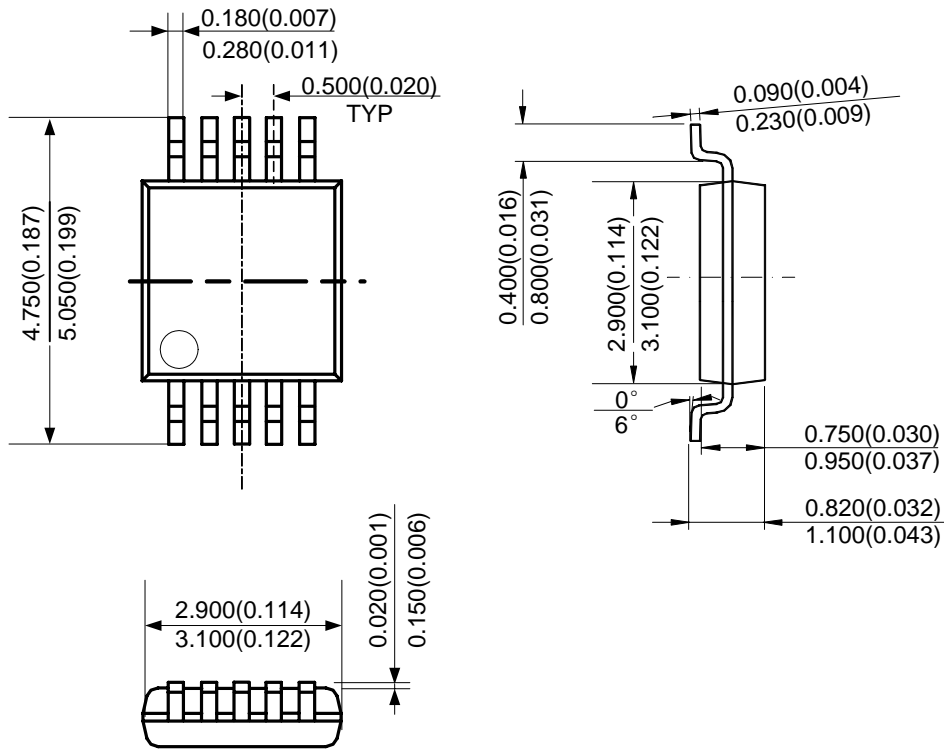

Figure 16. Quick Start and Standby Mode

**Mechanical Dimensions**

**MSOP-10**

**Unit: mm(inch)**



Note: Eject hole, oriented hole and mold mark is optional.

**Mechanical Dimensions (Continued)**

**MSOP-8**

**Unit: mm(inch)**

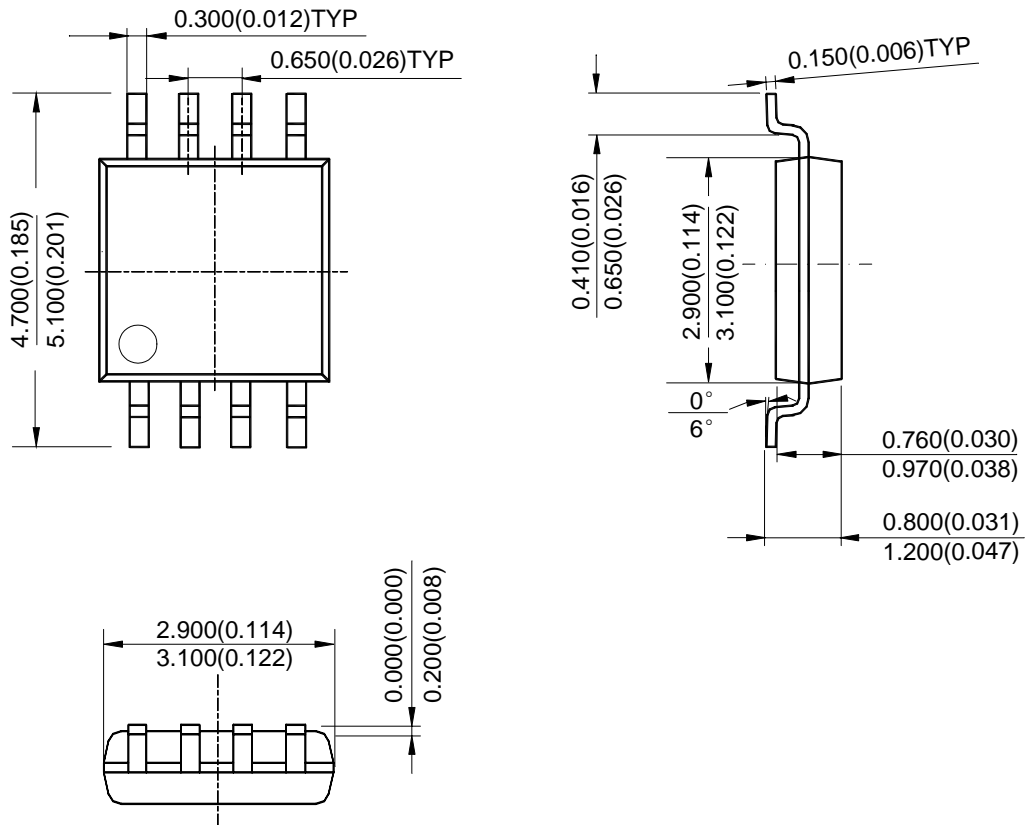

Note: Eject hole, oriented hole and mold mark is optional.

**Single Phase Full-wave Motor Driver for Silent Fan Motor**

**AM9789**

**Mechanical Dimensions (Continued)**

**DFN-3x3-8**

**Unit: mm(inch)**

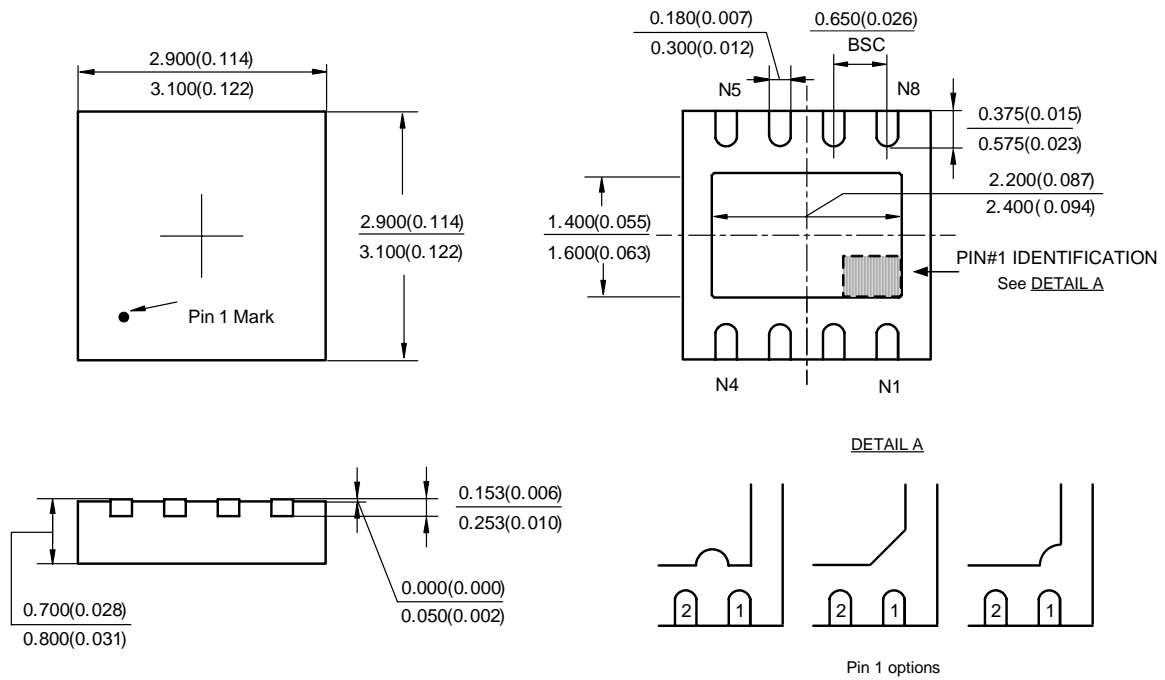



**Single Phase Full-wave Motor Driver for Silent Fan Motor**

**AM9789**

**Mechanical Dimensions (Continued)**

**DFN-3x3-10**

**Unit: mm(inch)**

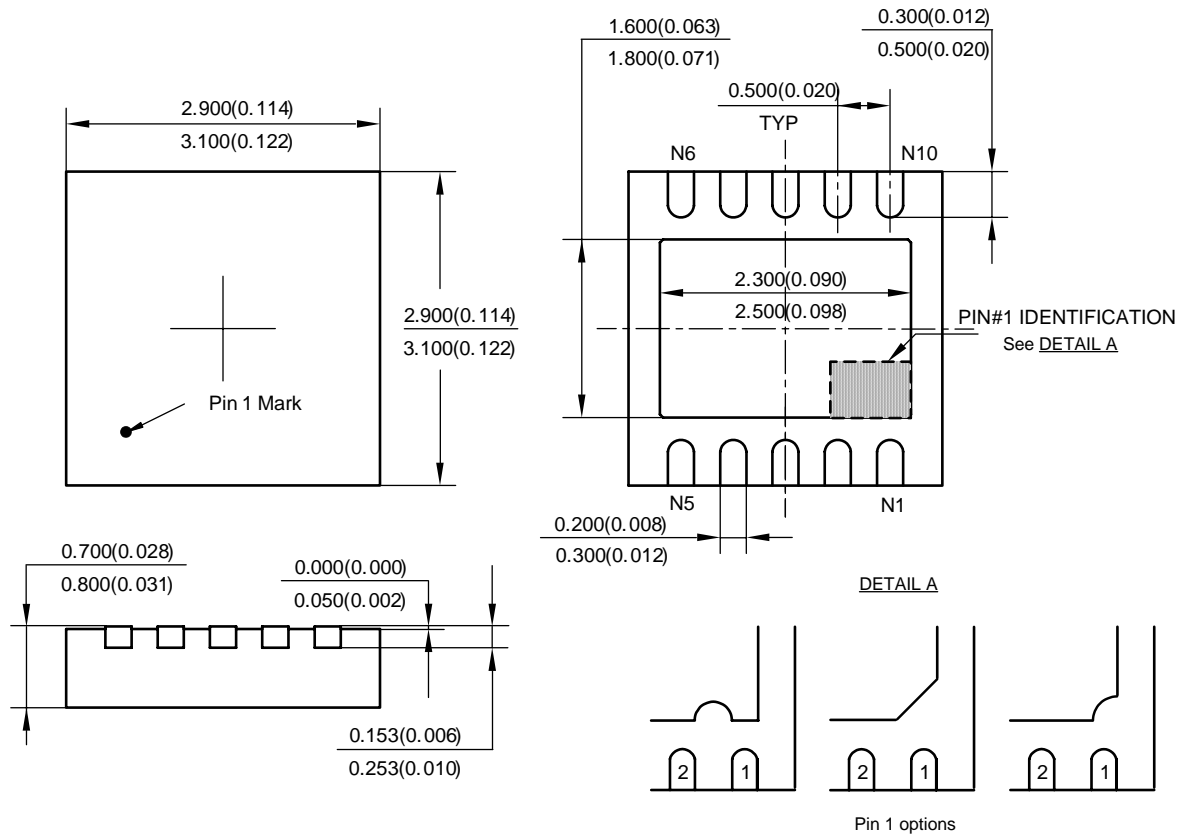



## **BCD Semiconductor Manufacturing Limited**

<http://www.bcdsemi.com>

### **IMPORTANT NOTICE**

BCD Semiconductor Manufacturing Limited reserves the right to make changes without further notice to any products or specifications herein. BCD Semiconductor Manufacturing Limited does not assume any responsibility for use of any its products for any particular purpose, nor does BCD Semiconductor Manufacturing Limited assume any liability arising out of the application or use of any its products or circuits. BCD Semiconductor Manufacturing Limited does not convey any license under its patent rights or other rights nor the rights of others.

---

#### **MAIN SITE**

##### **- Headquarters**

##### **BCD Semiconductor Manufacturing Limited**

No. 1600, Zi Xing Road, Shanghai Zizhu Science-based Industrial Park, 200241, China  
Tel: +86-21-24162266, Fax: +86-21-24162277

##### **- Wafer Fab**

##### **Shanghai SIM-BCD Semiconductor Manufacturing Co., Ltd.**

800 Yi Shan Road, Shanghai 200233, China  
Tel: +86-21-6485 1491, Fax: +86-21-5450 0008

#### **REGIONAL SALES OFFICE**

##### **Shenzhen Office**

##### **Shanghai SIM-BCD Semiconductor Manufacturing Co., Ltd., Shenzhen Office**

Unit A Room 1203, Skyworth Bldg., Gaoxin Ave. 1.S., Nanshan District, Shenzhen, China  
Tel: +86-755-8826 7951  
Fax: +86-755-8826 7865

##### **Taiwan Office**

##### **BCD Semiconductor (Taiwan) Company Limited**

4F, 298-1, Rui Guang Road, Nei-Hu District, Taipei, Taiwan  
Tel: +886-2-2656 2808  
Fax: +886-2-2656 2806

##### **USA Office**

##### **BCD Semiconductor Corp.**

30920 Huntwood Ave. Hayward, CA 94544, USA  
Tel : +1-510-324-2988  
Fax: +1-510-324-2788