

Rev	AWO #	Description	Date	Appr
-		RELEASED	9/5/08	

APPROVED: \_\_\_\_\_  
 DATE: \_\_\_\_\_ TITLE: \_\_\_\_\_

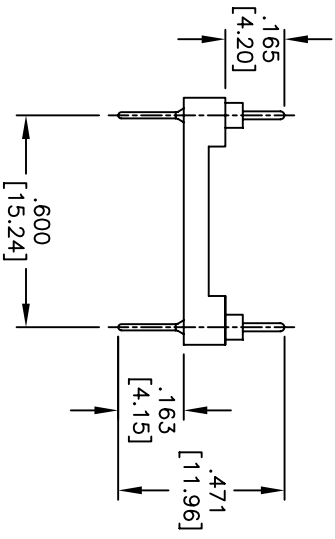
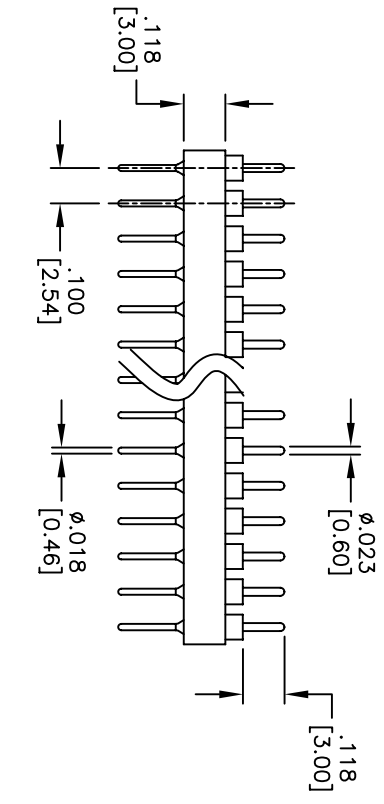
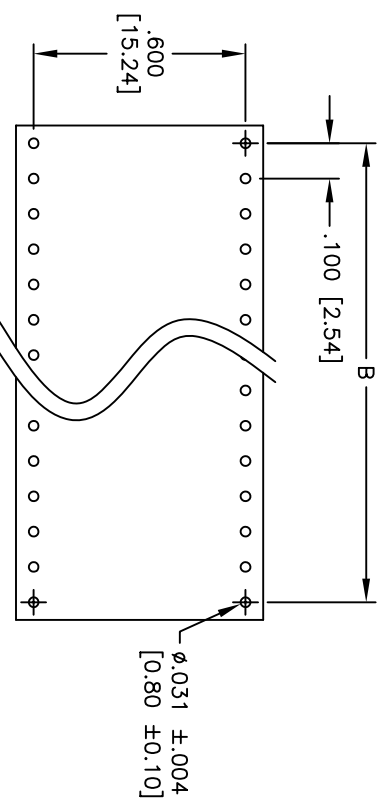
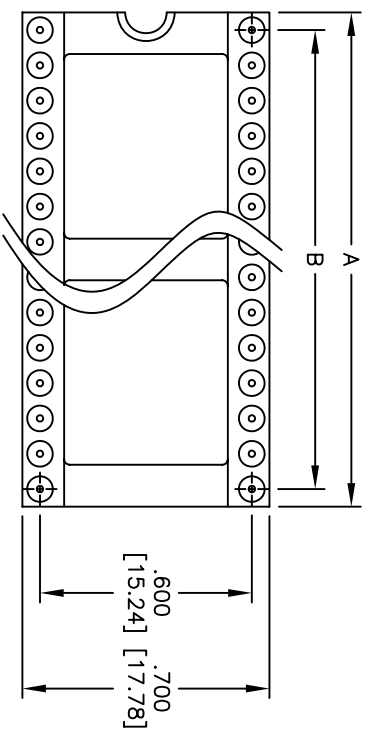

**SPECIFICATIONS:**

- Material: Insulator: PBT, Glass reinforced, rated UL 94V-0
- Insulator color: Black
- Contacts: Phosphor Bronze
- Plating: Gold over Nickel underplate overall
- Electrical: Operating voltage: 250 VAC max
- Current rating: 1 Amp max
- Contact resistance: 30 mohms max initial
- Insulation resistance: 1,000 Mohms min
- Dielectric withstanding voltage: 500 VAC for 1 minute
- Temperature Rating: Operating temperature: -55°C to +105°C
- Environmental: Lead free, RoHS compliant
- Recommended soldering temp: 230°C for 5 seconds

Positions: 24, 28, 32, 36, 40, 42, 48, 50 & 52  
 A = .100 [2.54] x No. of Positions  
 B = .100 [2.54] x No. of Spaces

UNLESS OTHERWISE SPECIFIED	
ALL DIMENSIONS ARE INCHES [MM]	
TOLERANCES: EXCEPT AS NOTED	
INCHES	HOLES
X ± .10	ØXX ± .10
.XX ± .020	ØXX ± .015
.XXX ± .015	ØXXX ± .010
APPROVALS	DATE
DRAWN	SS
CHECKED	
APPROVED	

**ADAM TECH**  
 909 Rahway Avenue, Union, NJ 07083  
 Phone: 908-687-5000 Fax: 908-687-5710

TITLE: SCREW MACHINE TERMINAL STRIP  
 .100 [2.54] SPACING, GOLD PLATED

SIZE	PART NO.	REV.
X	TMC-6XX-1-G	-
SCALE:	NTS	SHEET 1 OF 1

