

| Rev | AWO # | Description | Date    | Appr |
|-----|-------|-------------|---------|------|
| -   |       | RELEASED    | 12/3/10 |      |

APPROVED: \_\_\_\_\_  
 DATE: \_\_\_\_\_ TITLE: \_\_\_\_\_

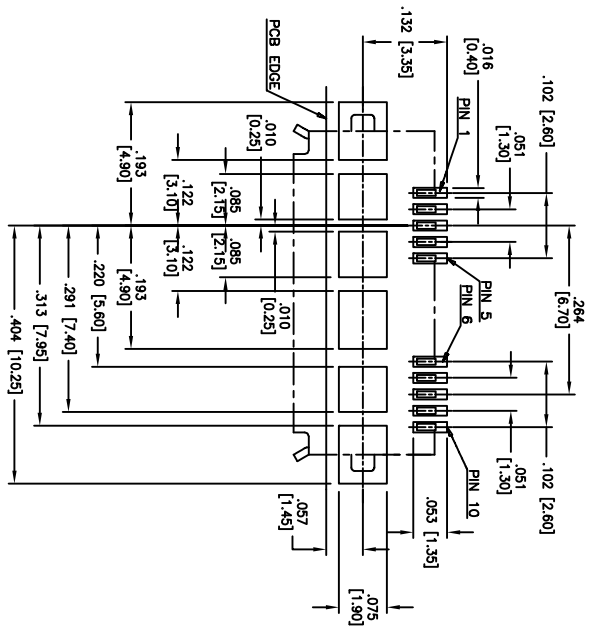
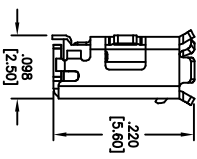
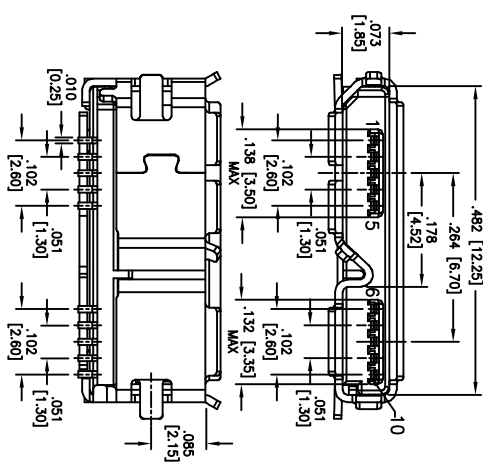
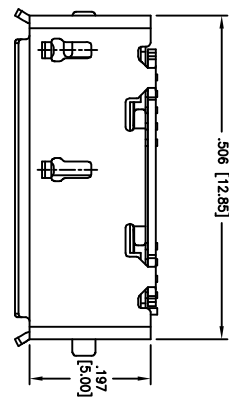

**SPECIFICATIONS:**

- Material: Insulator: Hi-Temp Thermoplastic, rated UL 94V-0
- Insulator color: Black
- Contacts: Copper Alloy
- Shell: Stainless Steel, Nickel over plated
- Plating: Gold flash over Nickel underplate overall
- Electrical: Operating voltage: 30 VAC max. Current rating: 1 Amp max. Contact resistance: 50 mohms max. Insulation resistance: 100 Mohms min. @ 500 VDC Dielectric withstanding voltage: 250 VAC for 1 minute Temperature Rating: Operating temperature: -20°C to +85°C Environmental: Lead free, RoHS compliant. Recommended soldering temp: 260°C for 5 sec.

**ADAM TECH**

909 Railway Avenue, Union, NJ 07083  
 Phone: 908-687-5000 Fax: 908-687-5710

TITLE: MICRO USB 3.0 B TYPE, 10PIN, SMT

| UNLESS OTHERWISE SPECIFIED ALL DIMENSIONS ARE INCHES [MM] TOLERANCES: EXCEPT AS NOTED |            |
|---|------------|
| X   | ± .10      |
| .XX   | ± .020     |
| .XXX  | ± .015     |
| .XXX  | ± .010     |
| ØX  | ± .10      |
| ØXX   | ± .015     |
| ØXXX  | ± .010     |
| APPROVALS   |            |
| DRAWN   | AY 12/3/10 |
| CHECKED   | AH 12/3/10 |
| APPROVED  |            |

| SIZE | PART NO.       | SCALE | SHEET 1 OF 1 |
|------|----------------|-------|--------------|
| X    | MCR-B3-RA-TSMT | NTS   |              |