

28L0138-80R-10

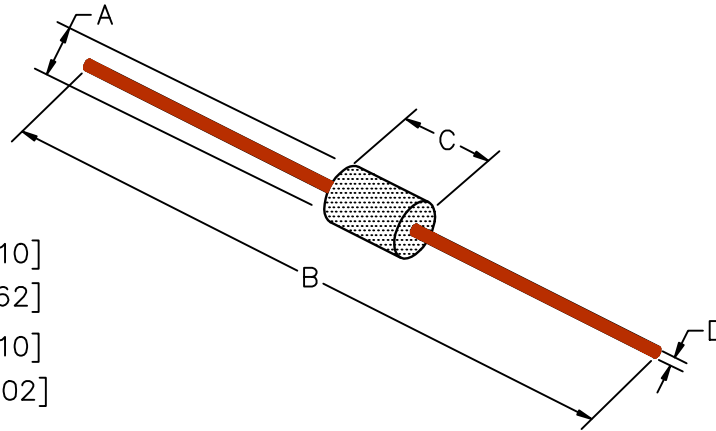

PHYSICAL DIMENSIONS:

A	3.51 [.138]	+ 0.25 [.010]
B	59.00 [2.32]	+ 1.57 [.062]
C	5.23 [.206]	+ 0.25 [.010]
D	0.64 [.025]	+ 0.05 [.002]

ELECTRICAL CHARACTERISTICS:				
	Z (Ω) @		DCR (Ω)	Rated Current
	25 MHz	100MHz		
Nominal	48	86		
Minimum	-	64		
Maximum	-	108	0.01	5,000 mA

UNCONTROLLED DOCUMENT



|Z| , R, AND X vs. FREQUENCY

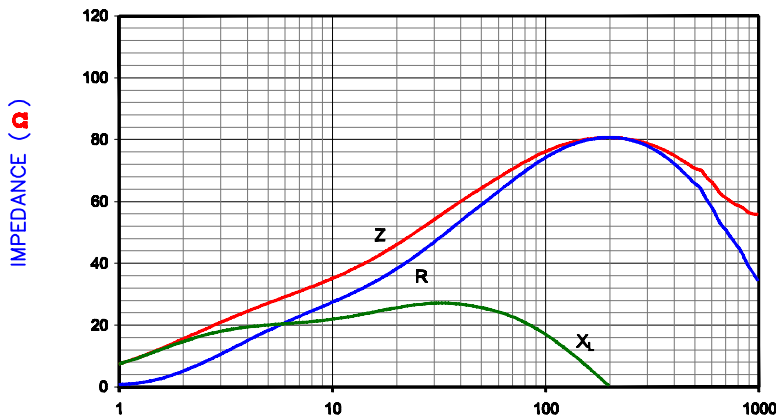

NOTES: UNLESS OTHERWISE SPECIFIED

1. TAPED AND REELED per CURRENT EIA SPECIFICATIONS 14" REELS, 4500 PCS/REEL.
2. COMPONENTS SHOULD BE ADEQUATELY PREHEATED BEFORE SOLDERING.
3. WIRE: C10200 OXYGEN FREE COPPER (99.95 MIN.) 22AWG (.025 DIA.)
4. PLATING: 100% TIN 5 μ ± 2 μ [200 μ in ± 80 μ in]
5. WEIGHT/1000: .25 kgs .55 lbs.
6. REFERENCE STEWARD CORE P/N 28B0138-*00.

DIMENSIONS ARE IN mm (INCHES).				THIS DOCUMENT CONTAINS INFORMATION WHICH IS PROPRIETARY AND CONFIDENTIAL TO STEWARD. NO PRODUCTION OR PUBLICATION OF THIS DOCUMENT IN WHOLE OR IN PART SHALL BE MADE WITHOUT WRITTEN AUTHORIZATION FROM STEWARD.			
G	ADD ROHS SYMBOL UPDATE COMPANY LOGO	04/24/07	JRK				
F	CHANGE P/N TO -10, REVISE NOTE 3&4	10/16/03	JRK				
E	UPDATE PRINT FORMAT REM SHEET 40F4 ADDED NOTES TO SHEET 20F3.	10/10/01	JRK	PROJECT/PART NUMBER: 28L0138-80R-10			
D	ADDED (*NOTE&DIM) TO SHT 30F4 CORRECTED DIM D ON SHT 2 OF 4	10/13/98	DTR	REV: G	PART TYPE: ASSEMBLY	DRAWN BY: BENTON	
C	UPDATE PRINT FORMAT	07/02/98	DTR	DATE: 06/21/90			
B	UPDATE DIM C	12/18/96	GEM	SCALE: NTS			
A	ORIGINAL DRAFT	06/21/90	B	SHEET: 2 of 3			
REV	DESCRIPTION	DATE	INT	TOOL # B0138			
				CAD # 28L0138-80R-10-2-G			