

## DUAL 4-INPUT NOR GATE

### FEATURES

- Output capability: standard
- I<sub>CC</sub> category: SSI

### GENERAL DESCRIPTION

The 74HC/HCT4002 are high-speed Si-gate CMOS devices and are pin compatible with "4002" of the "4000B" series. They are specified in compliance with JEDEC standard no. 7A.

The 74HC/HCT4002 provide the 4-input NOR function.

SYMBOL	PARAMETER	CONDITIONS	TYPICAL		UNIT
			HC	HCT	
t <sub>PHL</sub> / t <sub>PLH</sub>	propagation delay nA, nB, nC, nD to nY	C <sub>L</sub> = 15 pF V <sub>CC</sub> = 5 V	9	11	ns
C <sub>I</sub>	input capacitance		3.5	3.5	pF
C <sub>PD</sub>	power dissipation capacitance per gate	notes 1 and 2	16	22	pF

GND = 0 V; T<sub>amb</sub> = 25 °C; t<sub>r</sub> = t<sub>f</sub> = 6 ns

### Notes

1. C<sub>PD</sub> is used to determine the dynamic power dissipation (P<sub>D</sub> in μW):

$$P_D = C_{PD} \times V_{CC}^2 \times f_i + \sum (C_L \times V_{CC}^2 \times f_o) \text{ where:}$$

f<sub>i</sub> = input frequency in MHz                      C<sub>L</sub> = output load capacitance in pF  
f<sub>o</sub> = output frequency in MHz                      V<sub>CC</sub> = supply voltage in V  
Σ (C<sub>L</sub> × V<sub>CC</sub><sup>2</sup> × f<sub>o</sub>) = sum of outputs

2. For HC the condition is V<sub>I</sub> = GND to V<sub>CC</sub>  
For HCT the condition is V<sub>I</sub> = GND to V<sub>CC</sub> - 1.5 V

### PACKAGE OUTLINES

14-lead DIL; plastic (SOT27).

14-lead mini-pack; plastic (SO14; SOT108A).

### PIN DESCRIPTION

PIN NO.	SYMBOL	NAME AND FUNCTION
1, 13	1Y, 2Y	data outputs
2, 9	1A, 2A	data inputs
3, 10	1B, 2B	data inputs
4, 11	1C, 2C	data inputs
5, 12	1D, 2D	data inputs
6, 8	n.c.	not connected
7	GND	ground (0 V)
14	V <sub>CC</sub>	positive supply voltage

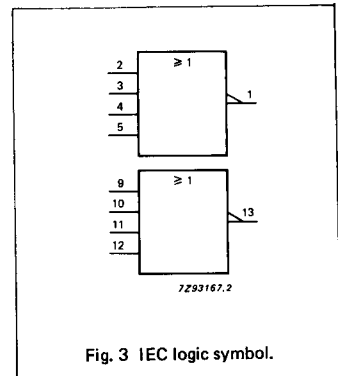
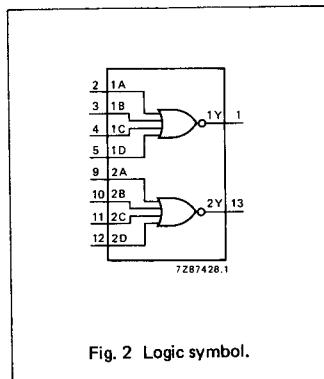
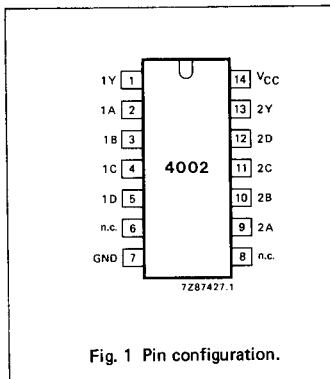

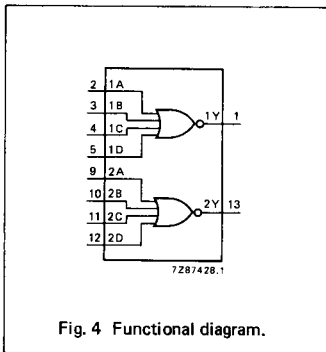

Fig. 4 Functional diagram.

FUNCTION TABLE

INPUTS				OUTPUT
nA	nB	nC	nD	nY
L	L	L	L	H
H	X	X	X	L
X	H	X	X	L
X	X	H	X	L
X	X	X	H	L

H = HIGH voltage level  
L = LOW voltage level  
X = don't care

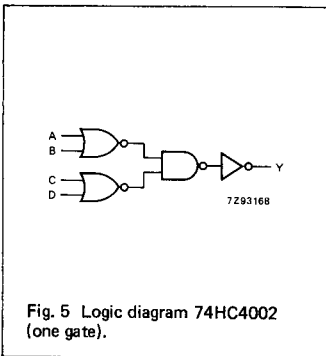

Fig. 5 Logic diagram 74HC4002 (one gate).

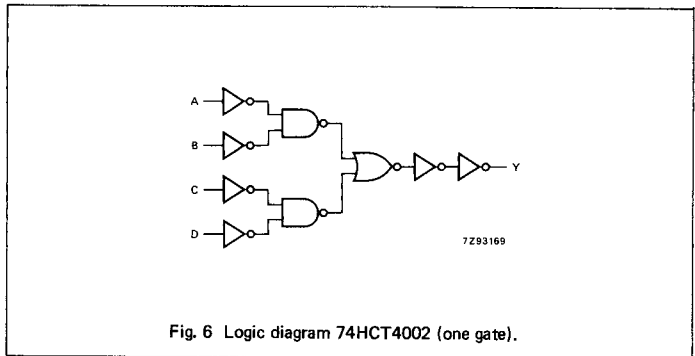

Fig. 6 Logic diagram 74HCT4002 (one gate).

**DC CHARACTERISTICS FOR 74HC**

For the DC characteristics see chapter "HCMOS family characteristics", section "Family specifications".

Output capability: standard

I<sub>CC</sub> category: SSI**AC CHARACTERISTICS FOR 74HC**GND = 0 V; t<sub>r</sub> = t<sub>f</sub> = 6 ns; C<sub>L</sub> = 50 pF

SYMBOL	PARAMETER	T <sub>amb</sub> (°C)						UNIT	TEST CONDITIONS		
		74HC							V <sub>CC</sub> V	WAVEFORMS	
		+25			-40 to +85		-40 to +125				
		min.	typ.	max.	min.	max.	min.		max.		
t <sub>PHL</sub> / t <sub>PLH</sub>	propagation delay nA, nB, nC, nD to nY		30 11 9	100 20 17		125 25 21		150 30 26	ns	2.0 4.5 6.0	Fig. 7
t <sub>THL</sub> / t <sub>TLH</sub>	output transition time		19 7 6	75 15 13		95 19 16		110 22 19	ns	2.0 4.5 6.0	Fig. 7

**DC CHARACTERISTICS FOR 74HCT**

For the DC characteristics see chapter "HCMOS family characteristics", section "Family specifications".

Output capability: standard

I<sub>CC</sub> category: SSI

**Note to HCT types**

The value of additional quiescent supply current ( $\Delta I_{CC}$ ) for a unit load of 1 is given in the family specifications. To determine  $\Delta I_{CC}$  per input, multiply this value by the unit load coefficient shown in the table below.

INPUT	UNIT LOAD COEFFICIENT
nA, nB, nC, nD	0.45

**AC CHARACTERISTICS FOR 74HCT**

GND = 0 V;  $t_r = t_f = 6$  ns;  $C_L = 50$  pF

SYMBOL	PARAMETER	T <sub>amb</sub> (°C)						UNIT	TEST CONDITIONS		
		74HCT							V <sub>CC</sub> V	WAVEFORMS	
		+25			-40 to +85		-40 to +125				
		min.	typ.	max.	min.	max.	min.				max.
t <sub>PHL</sub> / t <sub>PLH</sub>	propagation delay nA, nB, nC, nD to nY		13	22		28		33	ns	4.5	Fig. 7
t <sub>THL</sub> / t <sub>TLH</sub>	output transition time		7	15		19		22	ns	4.5	Fig. 7

**AC WAVEFORMS**

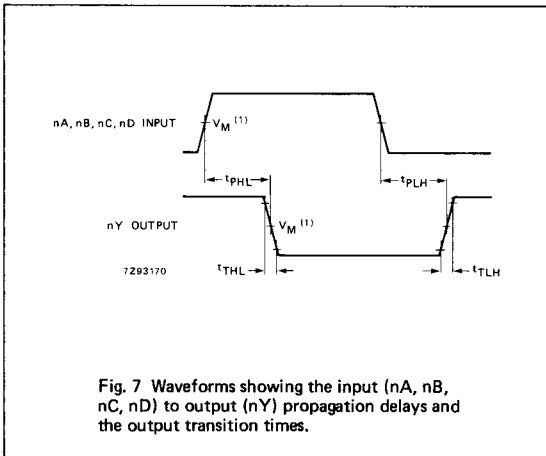

Fig. 7 Waveforms showing the input (nA, nB, nC, nD) to output (nY) propagation delays and the output transition times.

**Note to AC waveforms**

(1) HC : V<sub>M</sub> = 50%; V<sub>I</sub> = GND to V<sub>CC</sub>.  
HCT: V<sub>M</sub> = 1.3 V; V<sub>I</sub> = GND to 3 V.