

SAW Filter

FAR-F5KB-942M50-B4EB

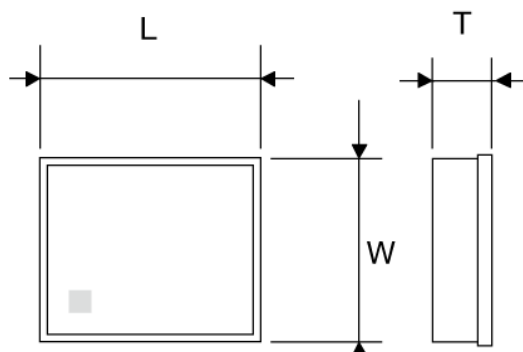

■ Features

- Item Summary
GSM900 , Rx, 504
- Lifecycle Stage
Mass Production
- Standard packaging quantity (minimum)
Taping Embossed 3000 , 15000pcs

■ Products characteristics table

Temperature Range	-30 to +85°C
GSM	900
Use	GSM
Transmitting / Receiving	Rx Filter
Insertion Loss	1.6dB
Attenuation	26dB
RoHS Compliance	Yes
Halogen Free	Yes
Soldering Method	Reflow

■ External Dimensions

L	1.4mm +0.1:-0.1
W	1.0mm +0.1:-0.1
T	0.5mm max

2015.06.03

The data is reference only. Electrical characteristics vary depending on environment or measurement condition.
 TAIYO YUDEN reserves the right to make change to the Date at any time without notice.
 Before making final selection, please check product specification.



MSL1

* Pb Free Part

Customer Name	Standard	TAIYO YUDEN Mobile Technology Co.,Ltd.	
System	EGSM-Rx (50/150)	Date	March 31, 2010
Part Number	FAR-F5KB-942M50-B4EB	Version 4.0 d	

Table 1 Electrical Specification

Passband : 925 ~ 960 MHz						
Item	Condition (MHz)	Specification			Unit	Remark
		Min.	Typ.	Max.		
Insertion Loss	925 ~ 960	-	1.6	2.5	dB	
Ripple	925 ~ 960	-	0.4	1.6	dB	
Absolute attenuation	DC ~ 880	40	66	-	dB	
	880 ~ 905	30	38	-	dB	
	905 ~ 915	18	26	-	dB	
	980 ~ 1025	25	33	-	dB	
	1025 ~ 2880	36	50	-	dB	
	2880 ~ 6000	30	50	-	dB	
VSWR(Input)	925 ~ 960	-	1.7	2.0	-	
VSWR(Output)	925 ~ 960	-	1.6	2.0	-	
Amplitude Balance (S ₂₁ /S ₃₁)	925 ~ 960	-1.0	0/ +0.5	+1.0	dB	
Phase Balance ((∠S ₂₁ -∠S ₃₁)+180)	925 ~ 960	-10	0/+4	+10	deg	
Input Impedance	Unbalanced	50			ohm	
Output Impedance	Balanced	150//82nH			ohm	
Input Power	925 ~ 960	-	-	+13	dBm	
Operating temperature		-30 ~ +85			°C	
Device size		1.4typ. x 1.0typ. x 0.50typ.			mm	



MSL1

* Pb Free Part

Customer Name	Standard	TAIYO YUDEN Mobile Technology Co.,Ltd.	
System	EGSM-Rx (50/150)	Date	March 31, 2010
Part Number	FAR-F5KB-942M50-B4EB	Version 4.0 d	

Dimension

Device size: 1.4typ. x 1.0typ. x 0.50typ.

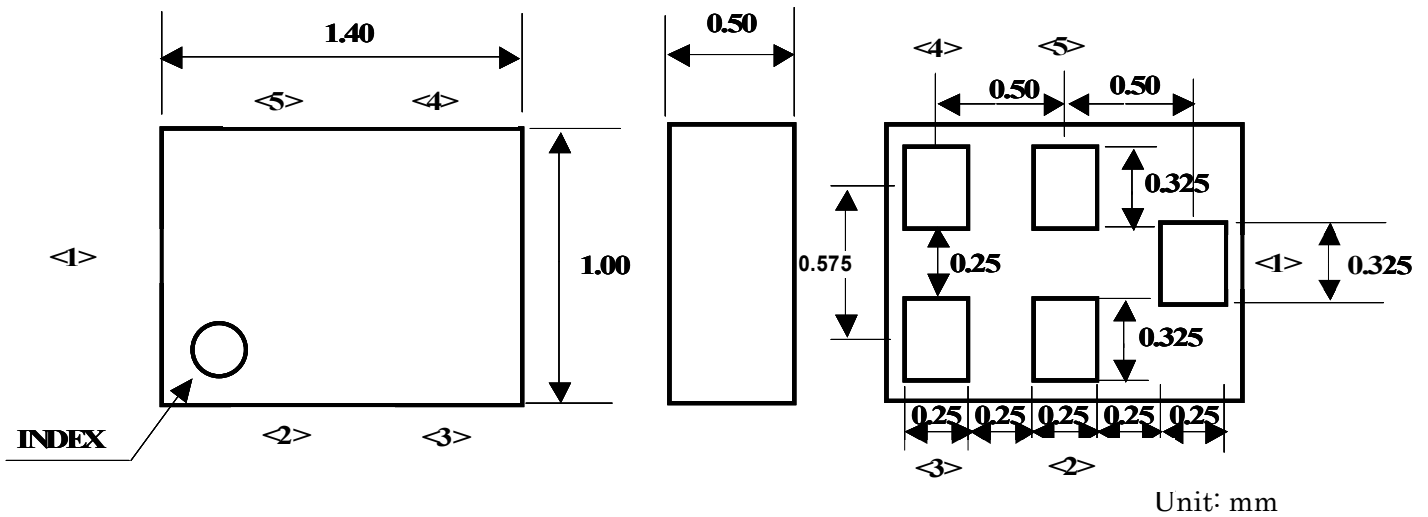

Pin Configuration

Pin No.	Symbol	Function
1	IN	Unbalanced pin
2	GND	Ground
3	OUT	Balanced pin
4	OUT	Balanced pin
5	GND	Ground

Evaluation Circuit

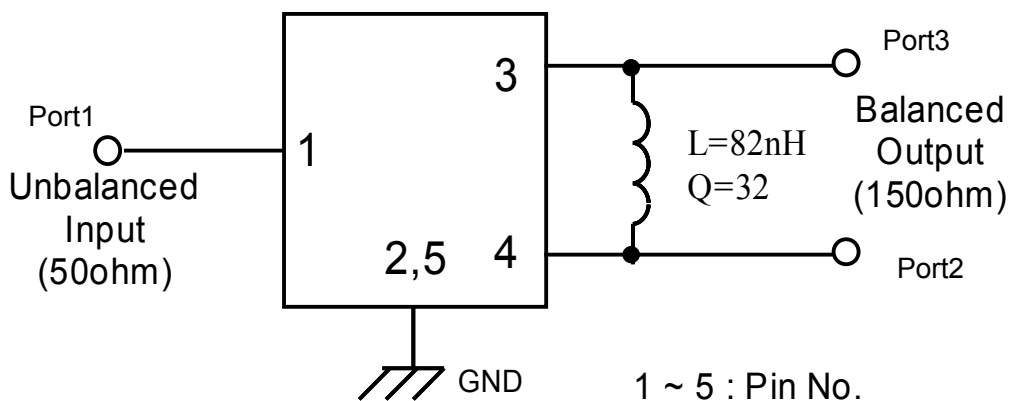



MSL1

* Pb Free Part

Customer Name	Standard	TAIYO YUDEN Mobile Technology Co.,Ltd.	
System	EGSM-Rx (50/150)	Date	March 31, 2010
Part Number	FAR-F5KB-942M50-B4EB	Version 4.0 d	

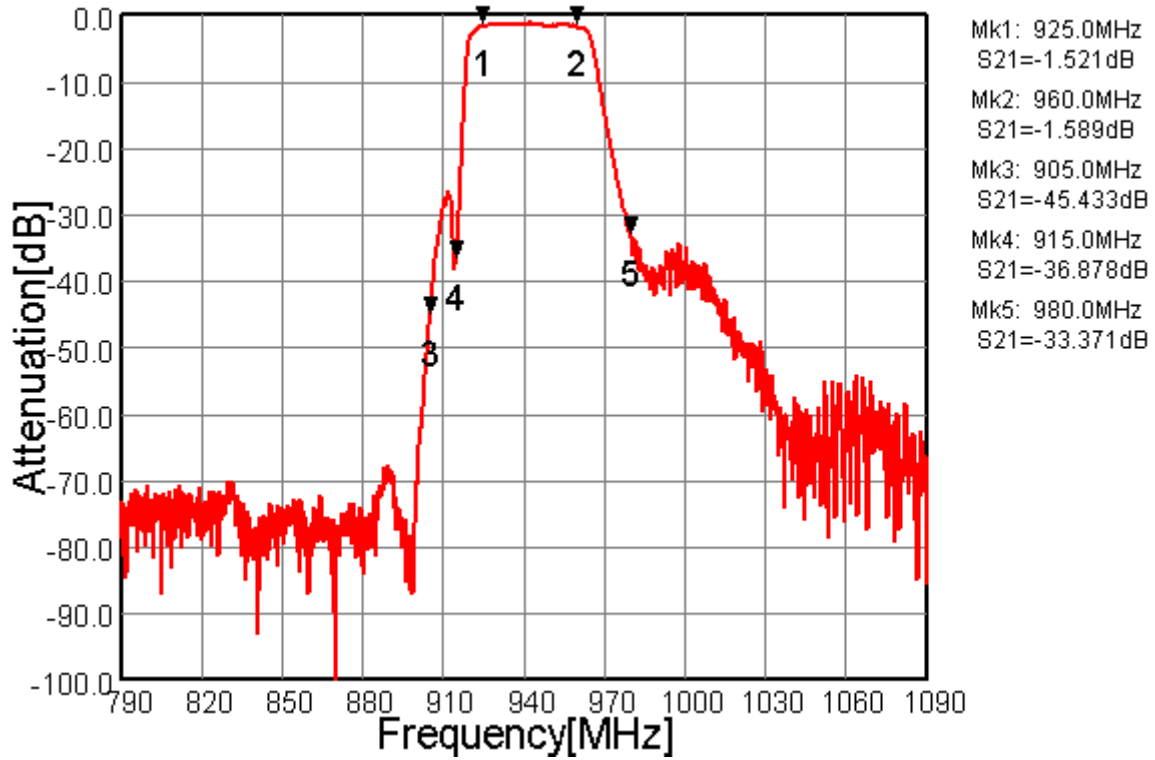

Fig.1 Pass-band Characteristics

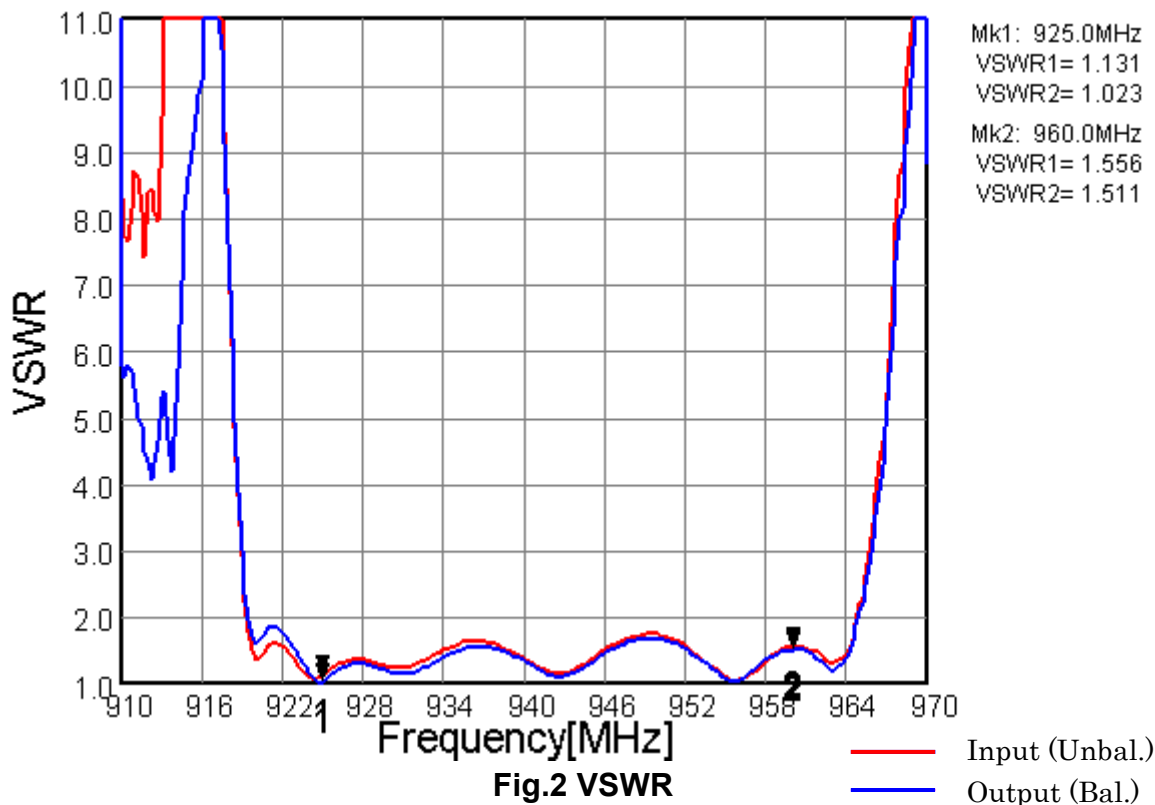

Fig.2 VSWR



MSL1

* Pb Free Part

Customer Name	Standard	TAIYO YUDEN Mobile Technology Co.,Ltd.	
System	EGSM-Rx (50/150)	Date	March 31, 2010
Part Number	FAR-F5KB-942M50-B4EB	Version 4.0 d	

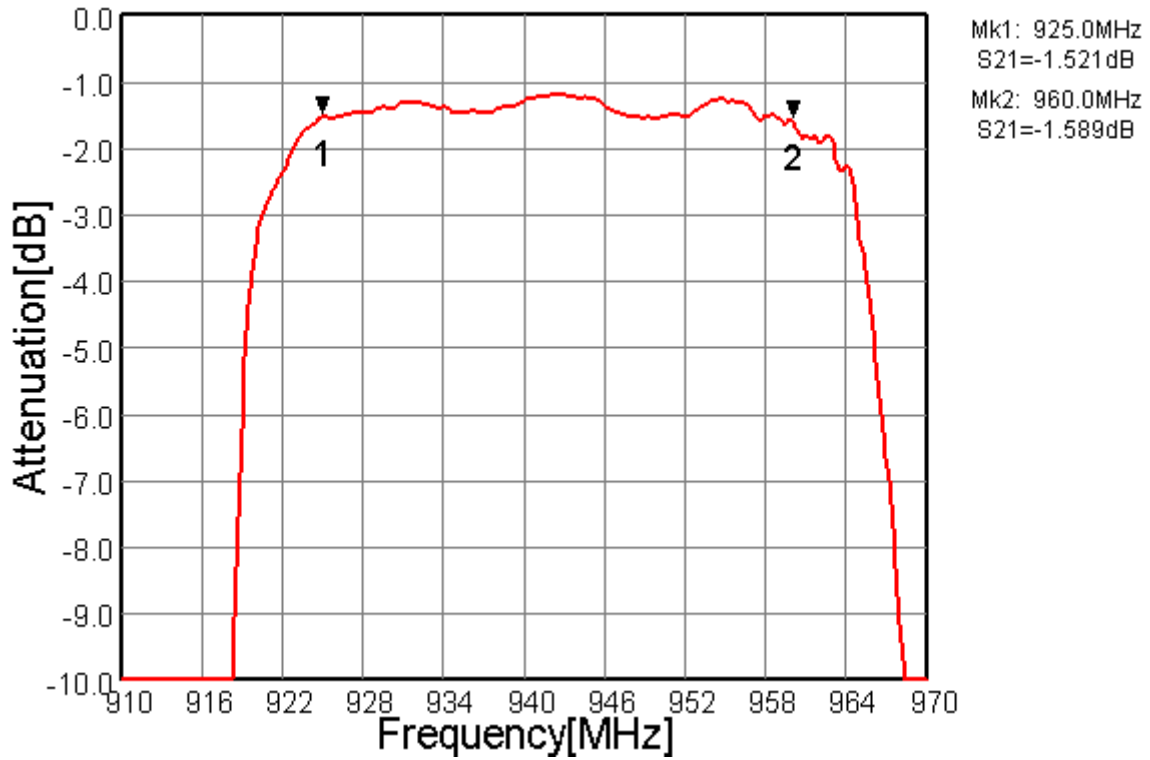

Fig.3 In-band Characteristics

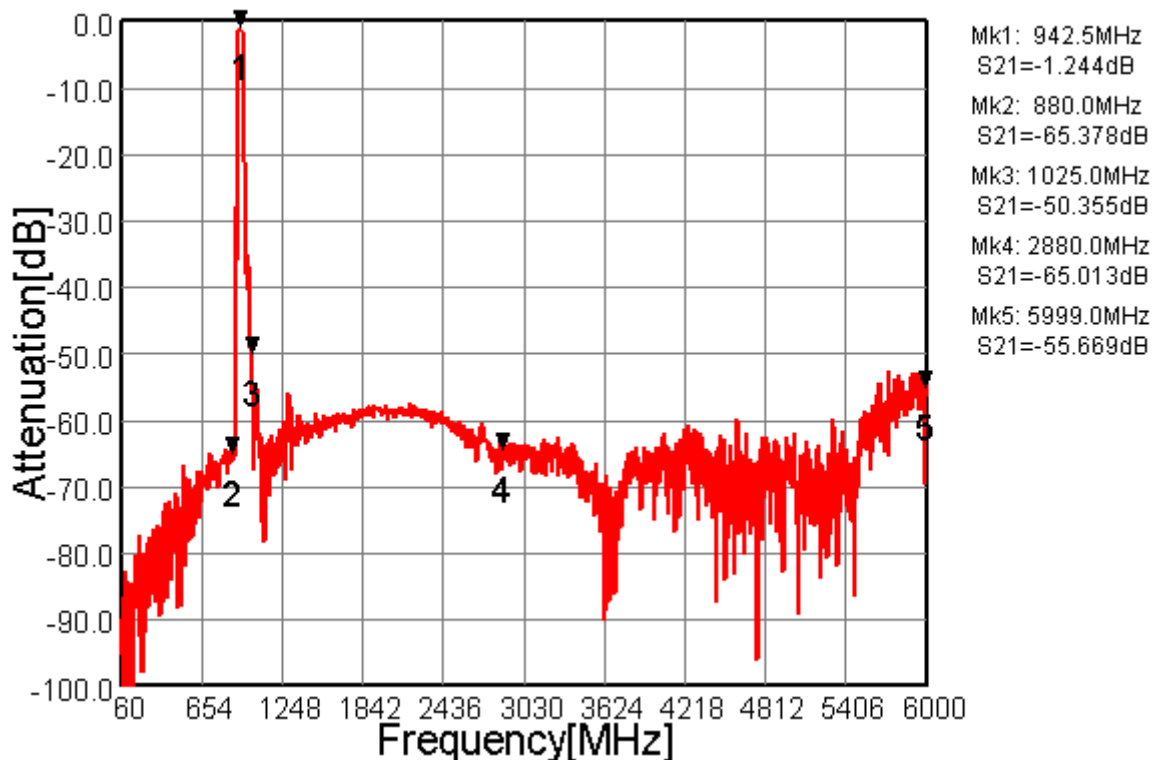

Fig.4 Wide-band Characteristics



MSL1

* Pb Free Part

Customer Name	Standard	TAIYO YUDEN Mobile Technology Co.,Ltd.	
System	EGSM-Rx (50/150)	Date	March 31, 2010
Part Number	FAR-F5KB-942M50-B4EB	Version 4.0 d	

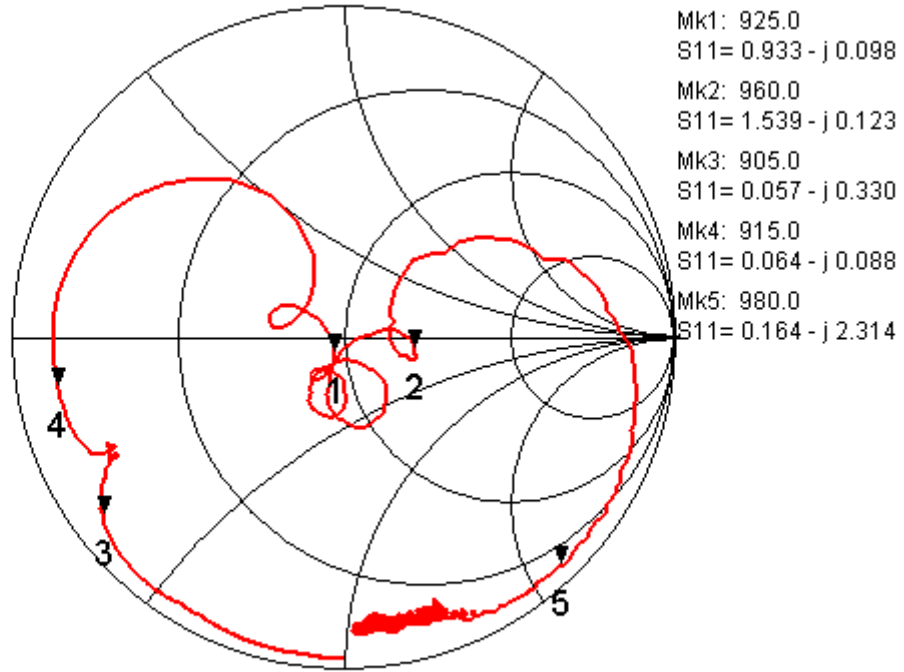

Fig.5 Input Impedance (Unbalance)

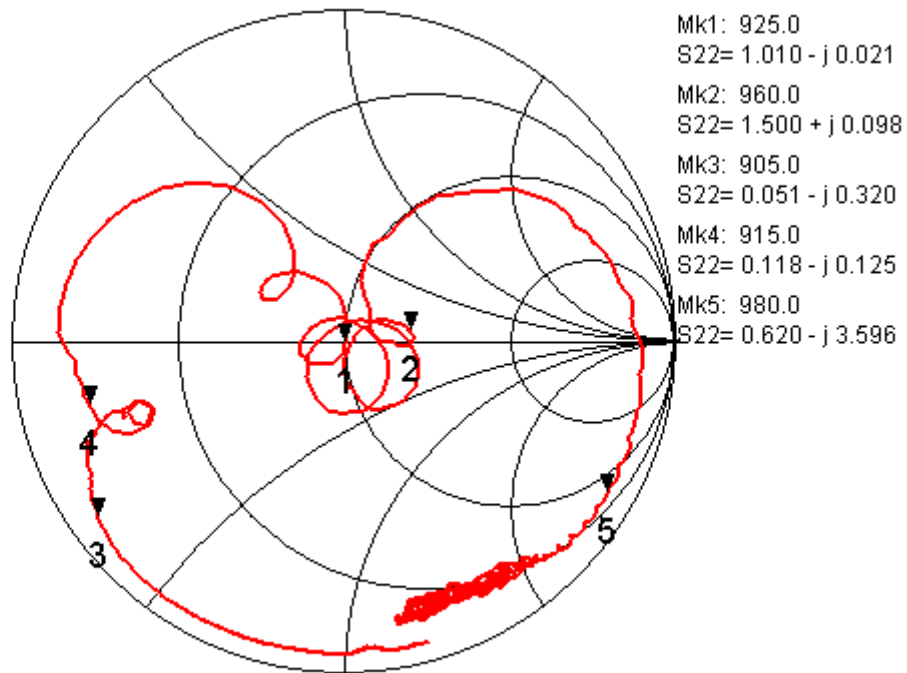

Fig.6 Output Impedance (Balance)



MSL1

* Pb Free Part

Customer Name	Standard	TAIYO YUDEN Mobile Technology Co.,Ltd.	
System	EGSM-Rx (50/150)	Date	March 31, 2010
Part Number	FAR-F5KB-942M50-B4EB	Version 4.0 d	

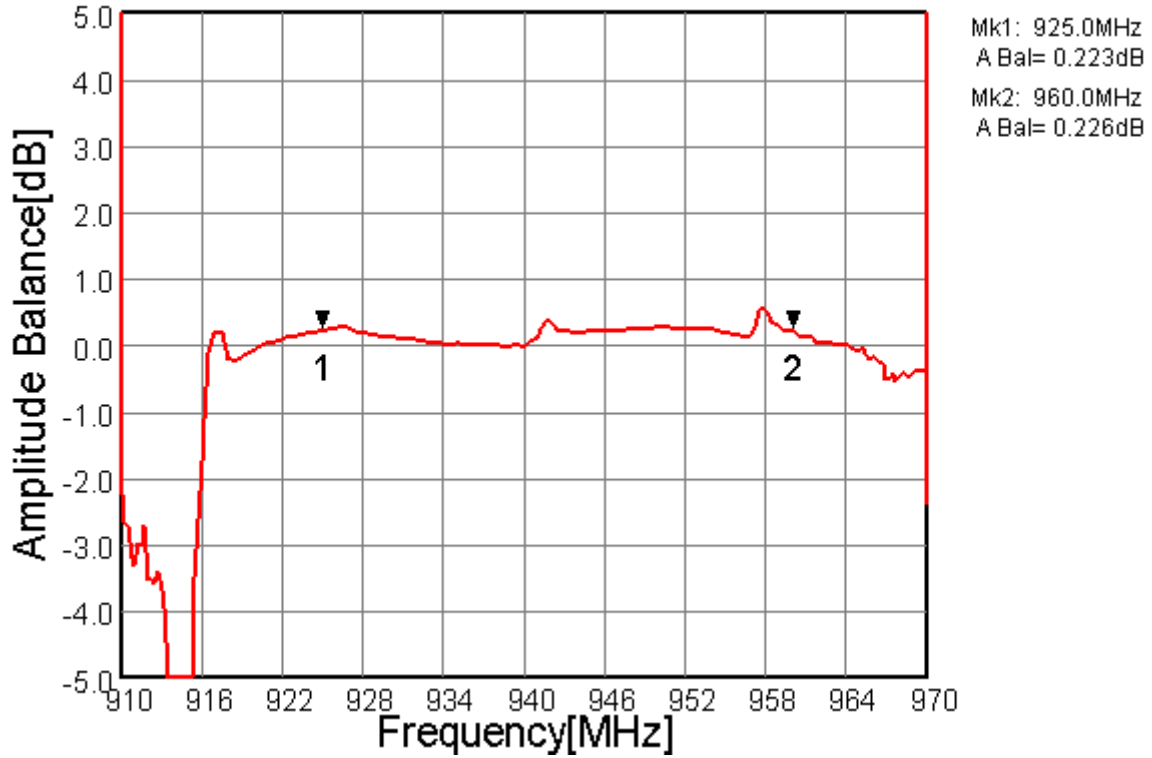

Fig.7 Amplitude Balance

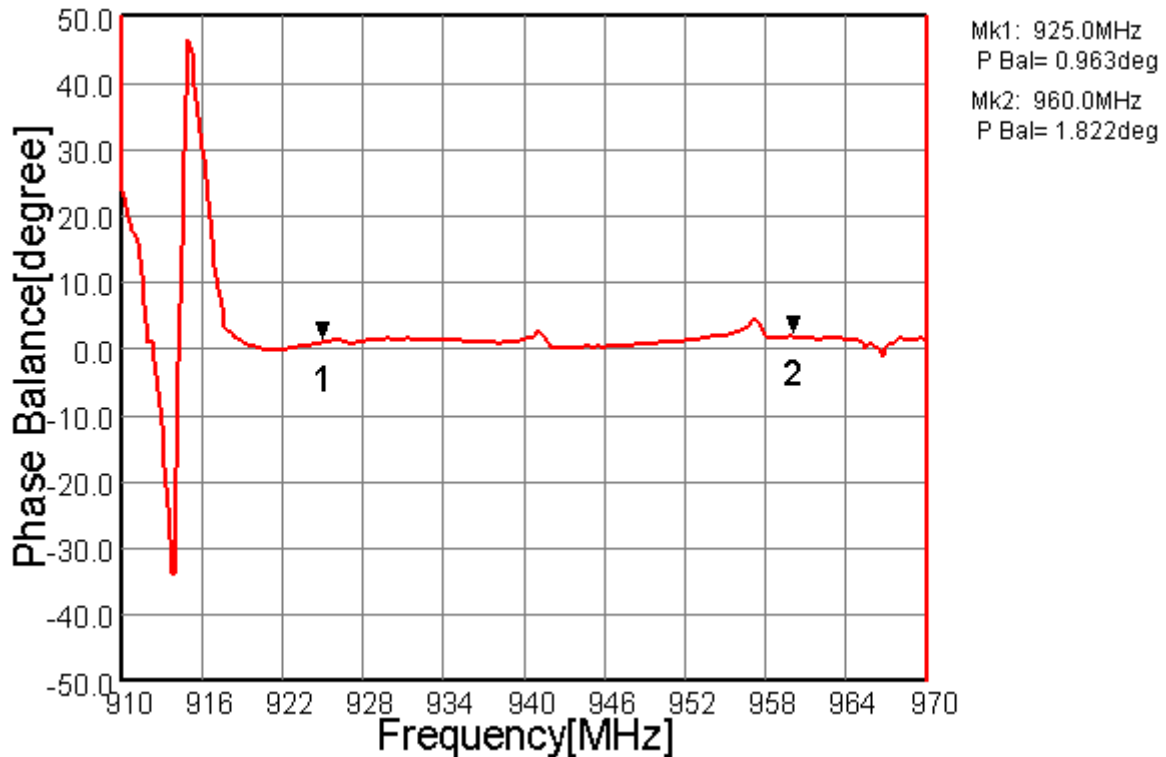

Fig.8 Phase Balance