

PREAMPLIFIER AND SPEAKER DRIVER USING TS925

by F. MARICOURT

The TS925 is an input/output rail to rail quad BiCMOS operational amplifier. It is able to operate with low supply voltages (2.7V) and to drive low output loads such as 32Ω.

As an illustration of these features, the following technical note highlights many of the advantages of the device in a global audio application.

APPLICATION CIRCUIT

Figure 1 shows two operators (A1, A4) used in a preamplifier configuration, and the two others in a push-pull configuration driving a headset.

The phantom ground is used as a common reference level ($V_{CC/2}$).

The power supply is delivered from two LR6 batteries (2x1.5V nominal).

Preamplifier : the operators A1 and A4 are wired with a non inverting gain of respectively :

- A1# $R4/(R3+R17)$
- A4# $R6/R5$

With the following values chosen :

- $R4=22k\Omega$ - $R3=50\Omega$ - $R17=1.2k\Omega$
- $R6=47k\Omega$ - $R5=1.2k\Omega$,

the gain of the preamplifier chain is thus 58dB.

Alternatively, the gain of A1 can be adjusted by choosing a JFET transistor Q1 instead of R17.

This JFET voltage controlled resistor arrangement forms an automatic level control (ALC) circuit, useful in many MIC preamplifier applications.

The mean rectified peak level of the output signal envelope is used to control the preamplifier gain.

Figure 1 : Electrical Schematic

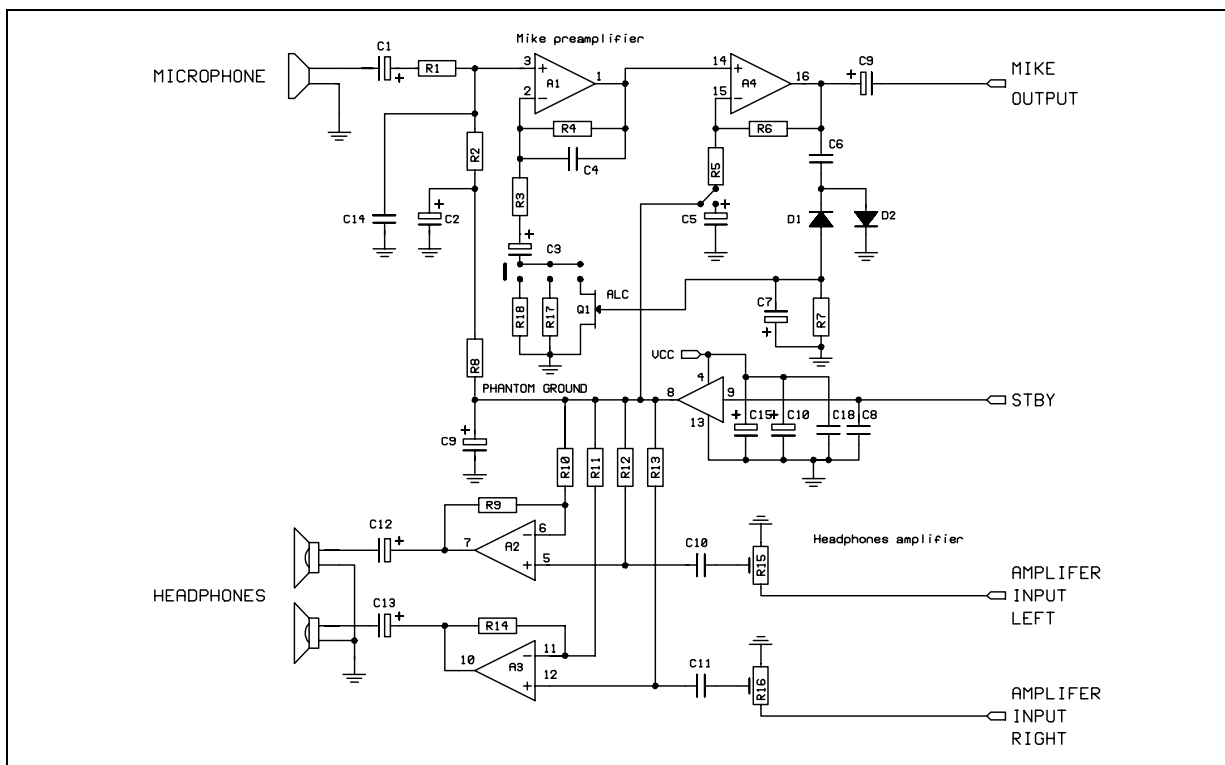

Figure 2 : Frequency Response of the Global Preamplifier Chain

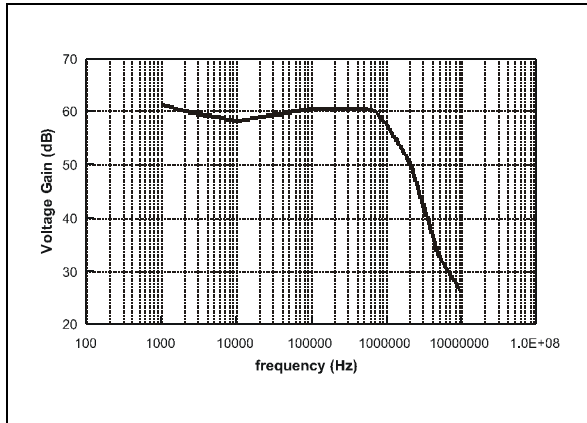
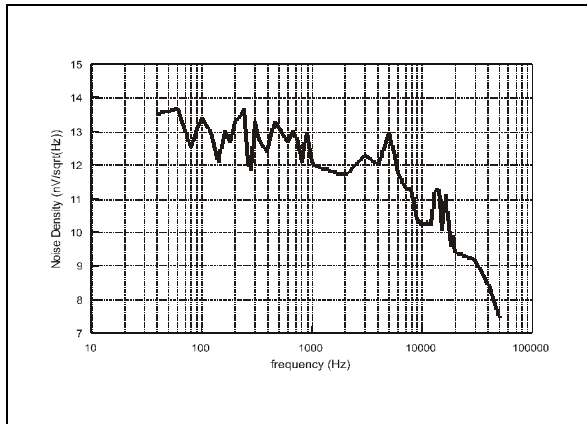

Figure 3 : Voltage Noise Density versus Frequency at Preamplifier Output



Headphone amplifier : the operators A2 and A3 are organized in a push-pull configuration with a gain of 5. The stereo inputs can be connected to a CD-player and the TS925 drives directly the head-phone speakers. This configuration shows the ability of the circuit to drive 32Ω load with a

maximum output swing and a high fidelity for reproducing sound and music.

Figure 4 shows the available signal swing at the headset outputs : two other rail to rail competitor parts are employed in the same circuit for comparison (note the much reduced clipping level and crossover distortion)

Figure 4 : Maximum Voltage Swing at Headphone Outputs (R_L) 32Ω

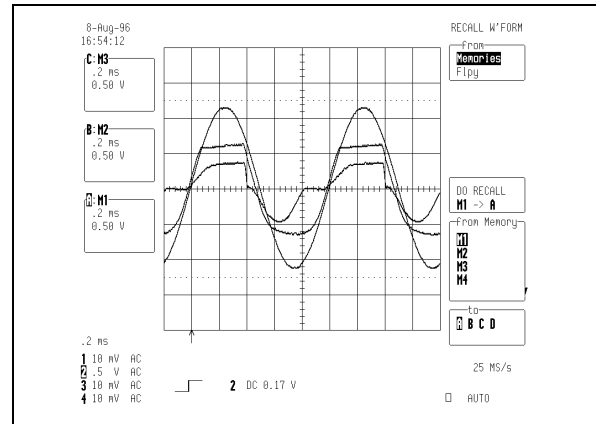
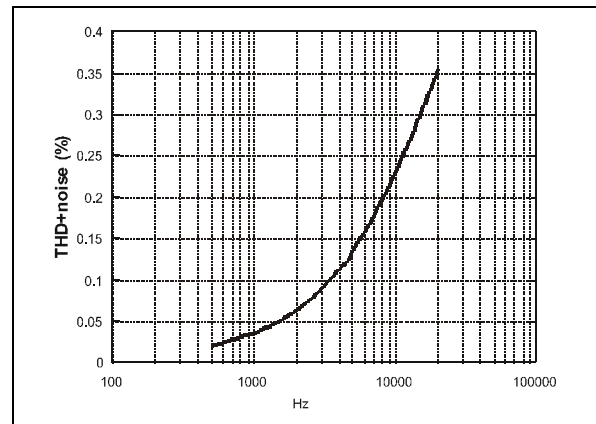

Figure 5 : THD+Noise versus Frequency (headphone outputs)



Information furnished is believed to be accurate and reliable. However, STMicroelectronics assumes no responsibility for the consequences of use of such information nor for any infringement of patents or other rights of third parties which may result from its use. No license is granted by implication or otherwise under any patent or patent rights of STMicroelectronics. Specifications mentioned in this publication are subject to change without notice. This publication supersedes and replaces all information previously supplied. STMicroelectronics products are not authorized for use as critical components in life support devices or systems without express written approval of STMicroelectronics.

© The ST logo is a registered trademark of STMicroelectronics

© 2000 STMicroelectronics - Printed in Italy - All Rights Reserved
STMicroelectronics GROUP OF COMPANIES

Australia - Brazil - China - Finland - France - Germany - Hong Kong - India - Italy - Japan - Malaysia - Malta - Morocco
Singapore - Spain - Sweden - Switzerland - United Kingdom

© <http://www.st.com>

