

27 - 31 GHz 1W Power Amplifier

TGA4509

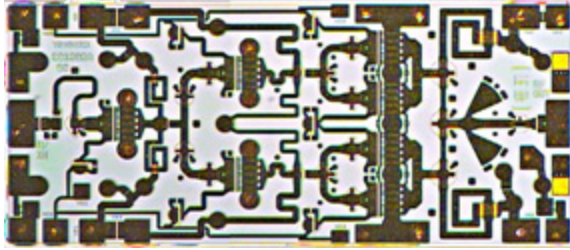

Key Features

- 22 dB Nominal Gain @ 30 GHz
- 30 dBm Nominal Pout @ P1dB
- 25% PAE @ P1dB
- -10 dB Nominal Return Loss
- Built-in Power Detector
- 0.25- μ m mmW pHEMT 3MI
- Bias Conditions: $V_d = 4 - 6$ V, $I_{dq} = 420$ mA
- Chip Dimensions 2.44 mm x 1.15 mm x 0.1 mm (0.096 x 0.045 x 0.004 in)

Primary Applications

- Point to Point Radio
- Point to Multi-point Radio
- LMDS
- Satellite Ground Terminal

Fixtured Measured Performance

Bias Conditions: $V_d = 6$ V, $I_d = 420$ mA

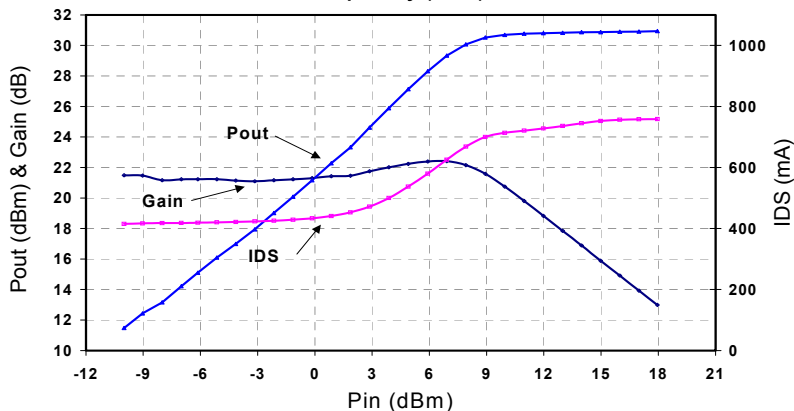
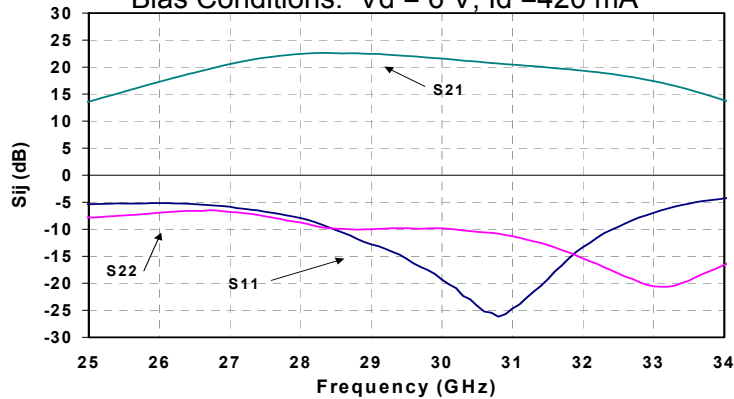

Data taken @ 30 GHz

Note: Datasheet is subject to change without notice.

TABLE I
MAXIMUM RATINGS 1/

Symbol	Parameter	Value	Notes
V ⁺	Positive Supply Voltage	7 V	
V ⁻	Negative Supply Voltage Range	-5 V to 0 V	
I _g	Gate Current	35.2 mA	
I ⁺	Positive Supply Current	930 mA	<u>2/</u> , <u>5/</u>
P _D	Power Dissipation	TBD	
P _{IN}	Input Continuous Wave Power	22 dBm	
T _{CH}	Operating Channel Temperature	150 °C	<u>3/</u> , <u>4/</u>
T _M	Mounting Temperature (30 seconds)	320 °C	
T _{STG}	Storage Temperature	-65 °C to 150 °C	

- 1/ These values represent the maximum operable values of this device
- 2/ Total current for the entire MMIC
- 3/ These ratings apply to each individual FET
- 4/ Junction operating temperature will directly affect the device mean time to failure (MTTF). For maximum life it is recommended that junction temperatures be maintained at the lowest possible levels.
- 5/ The maximum supply current from one side is 650 mA. From both sides, the maximum supply current is 930 mA.

TABLE II
ELECTRICAL CHARACTERISTICS
(T_A = 25°C, Nominal)

Parameter	Units	Typical
Drain Operating Voltage	V	6
Quiescent Current	mA	420
Small Signal Gain @ 30 GHz	dB	22
Gain Flatness	dB/50MHz	0.0660
Input Return Loss (Linear Small Signal)	dB	-10
Output Return Loss (Linear Small Signal)	dB	-10
Reverse Isolation	dB	-40
CW Output Power @ P1dB	dBm	30
Power Added Efficiency @ P1dB	%	25
P1dB temperature coeff. TC (-40 to +85 °C)	dB/deg C	0.0135

Measured Fixtured Data

Bias Conditions: $V_d = 6\text{ V}$, $I_d = 420\text{ mA}$

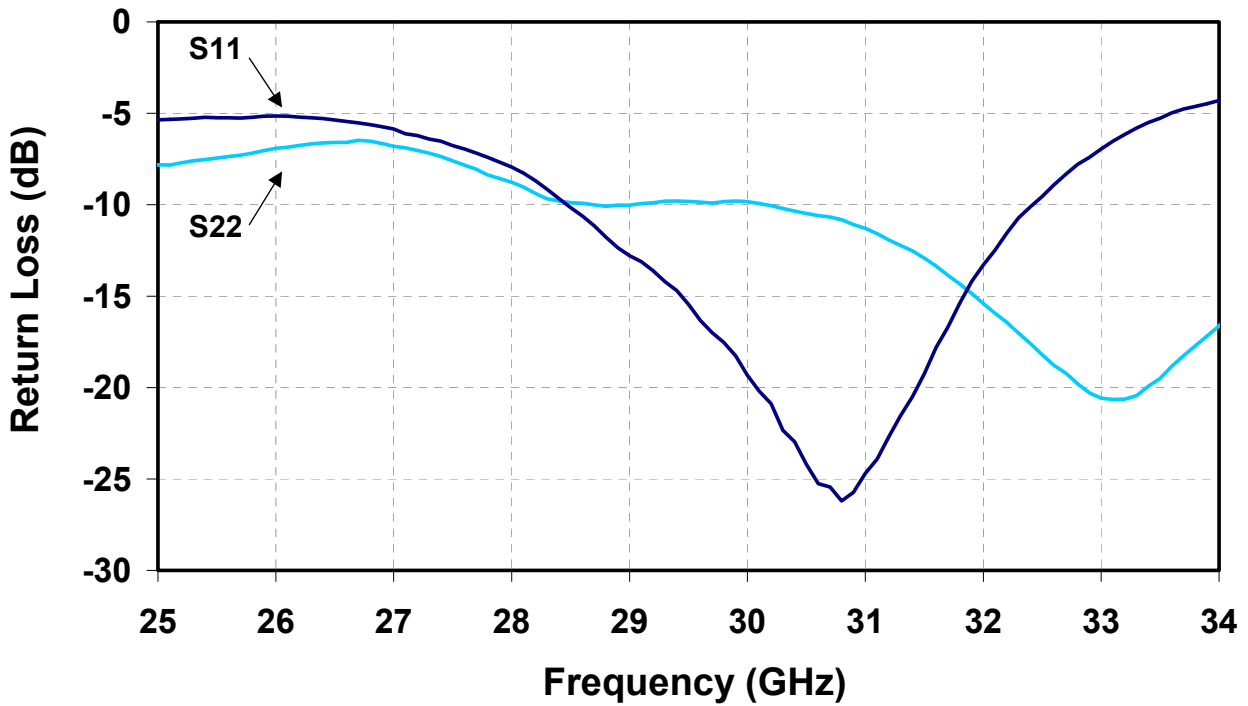
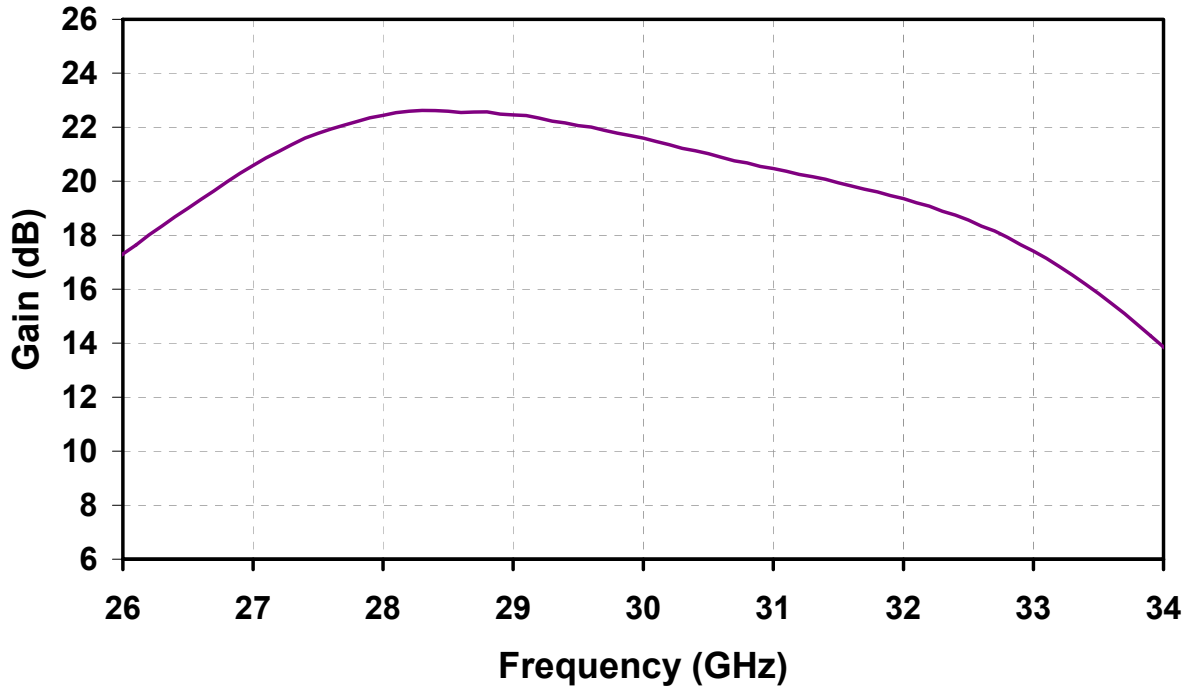

Measured Fixtured Data

Bias Conditions: $V_d = 6\text{ V}$, $I_d = 420\text{ mA}$

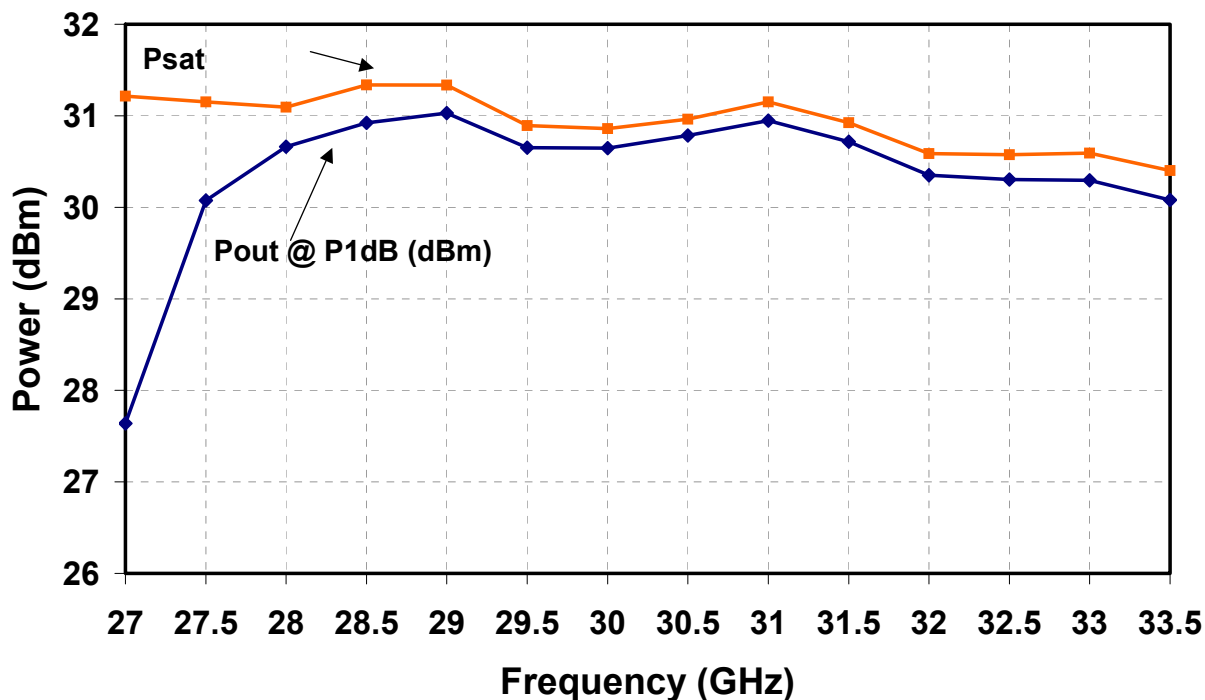

Recommended Assembly Diagram

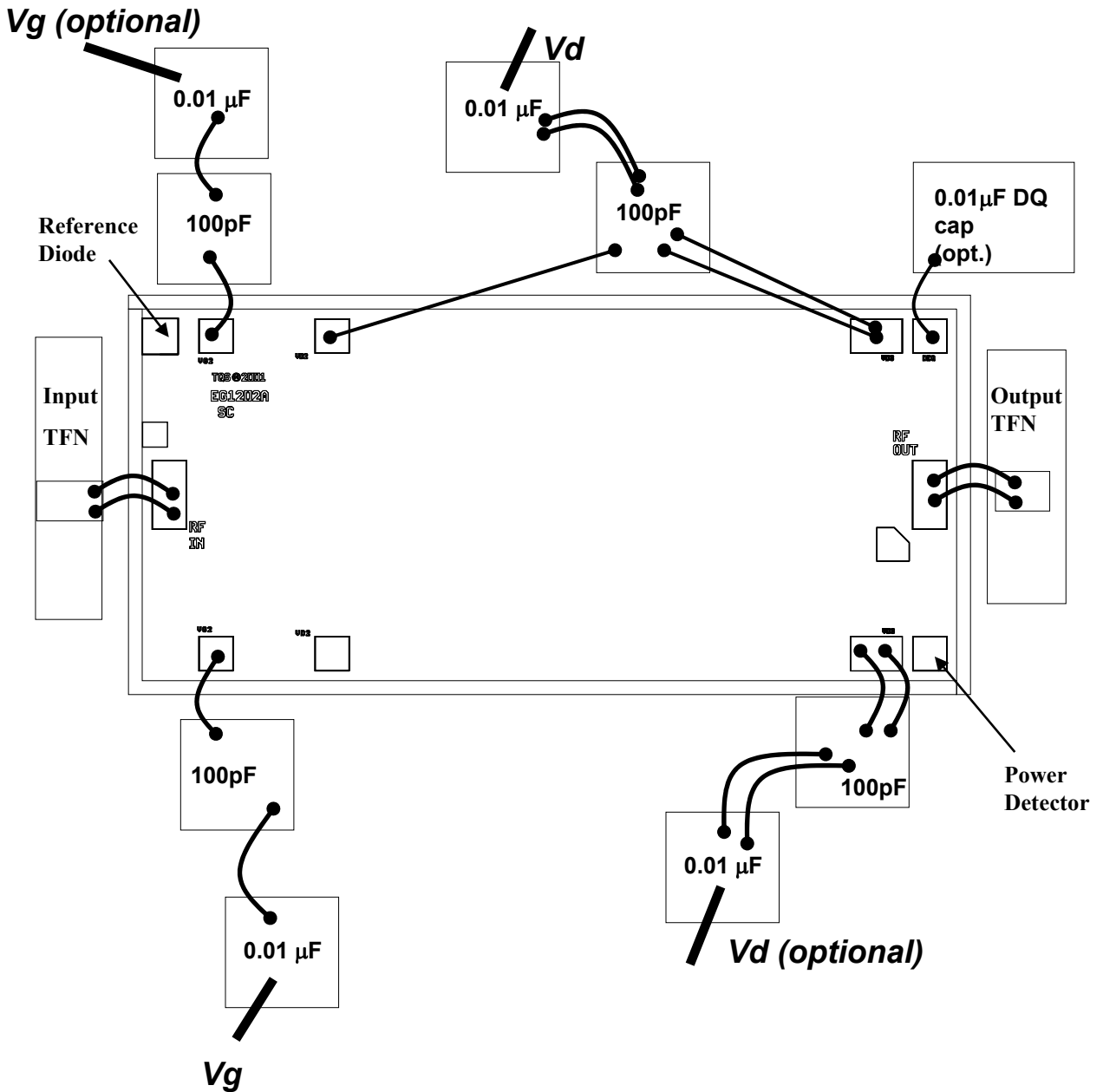

Notes:

1. Connection to power det, ref diode shown.
2. 1 μF cap on gate & drain power supplies are lines required.
3. Gate voltage can either be from one side or both sides.
4. Drain voltage is required from both sides for $I_d > 650$ mA.

GaAs MMIC devices are susceptible to damage from Electrostatic Discharge. Proper precautions should be observed during handling, assembly and test.

On-chip diode functions as envelope detector
External coupler and DC bias required

TGA4509 measured detector voltage offset vs output power with 20dB coupler: $V_b=0.8V$, $f = 30GHz$, Coupler loss is uncalibrated, $10K\Omega$ load

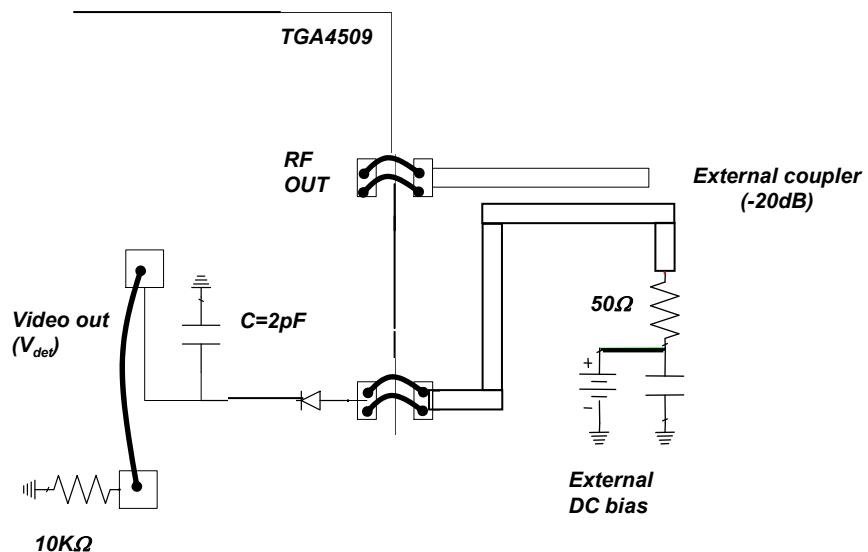
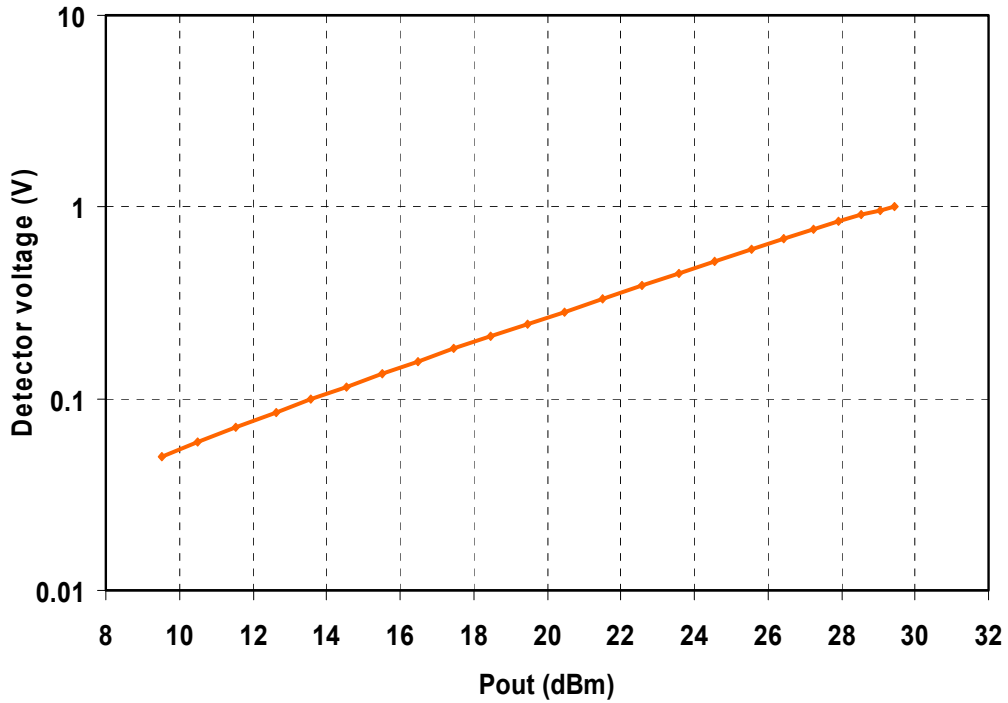

Mechanical Drawing

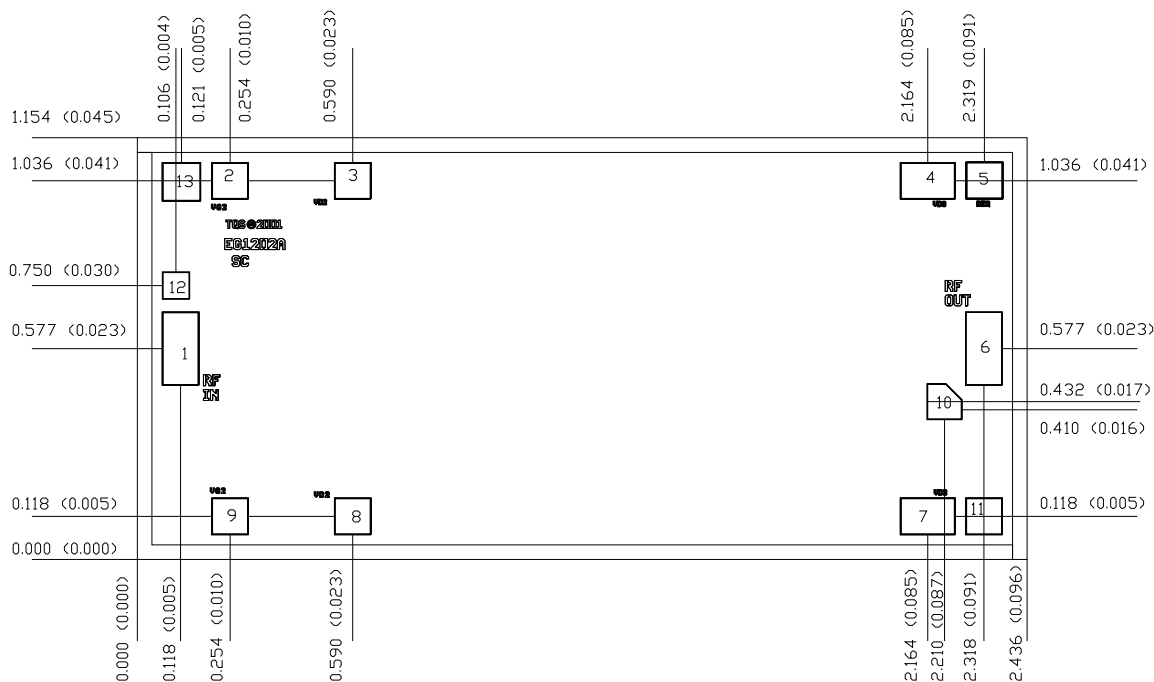

Units: millimeters (inches)

Thickness: 0.100 (0.004)

Chip edge to bond pad dimensions are shown to center of bond pad

Chip size tolerance: +/- 0.051 (0.002)

GND IS BACKSIDE OF MMIC

Bond Pad #1 (RF Input)	0.098 x 0.198 (0.004 x 0.008)
Bond Pad #2 (VG1)	0.098 x 0.098 (0.004 x 0.004)
Bond Pad #3 (VD1)	0.098 x 0.098 (0.004 x 0.004)
Bond Pad #4 (VD1)	0.148 x 0.098 (0.006 x 0.004)
Bond Pad #5 (DEQ)	0.098 x 0.098 (0.004 x 0.004)
Bond Pad #6 (RF Output)	0.098 x 0.198 (0.004 x 0.008)
Bond Pad #7 (VD2)	0.148 x 0.098 (0.006 x 0.004)
Bond Pad #8 (VD2) Optional	0.098 x 0.098 (0.004 x 0.004)
Bond Pad #9 (VG2) Optional	0.098 x 0.098 (0.004 x 0.004)
Bond Pad #10 (PWR DET)	0.095 x 0.096 (0.004 x 0.004)
Bond Pad #11 (PWR DET)	0.098 x 0.098 (0.004 x 0.004)
Bond Pad #12 (REF Diode)	0.071 x 0.071 (0.003 x 0.003)
Bond Pad #13 (REF Diode)	0.102 x 0.102 (0.004 x 0.004)

GaAs MMIC devices are susceptible to damage from Electrostatic Discharge. Proper precautions should be observed during handling, assembly and test.

Assembly Process Notes

Reflow process assembly notes:

- Use AuSn (80/20) solder with limited exposure to temperatures at or above 300 °C for 30 sec.
- An alloy station or conveyor furnace with reducing atmosphere should be used.
- No fluxes should be utilized.
- Coefficient of thermal expansion matching is critical for long-term reliability.
- Devices must be stored in a dry nitrogen atmosphere.

Component placement and adhesive attachment assembly notes:

- Vacuum pencils and/or vacuum collets are the preferred method of pick up.
- Air bridges must be avoided during placement.
- The force impact is critical during auto placement.
- Organic attachment can be used in low-power applications.
- Curing should be done in a convection oven; proper exhaust is a safety concern.
- Microwave or radiant curing should not be used because of differential heating.
- Coefficient of thermal expansion matching is critical.

Interconnect process assembly notes:

- Thermosonic ball bonding is the preferred interconnect technique.
- Force, time, and ultrasonics are critical parameters.
- Aluminum wire should not be used.
- Discrete FET devices with small pad sizes should be bonded with 0.0007-inch wire.
- Maximum stage temperature is 200 °C.

GaAs MMIC devices are susceptible to damage from Electrostatic Discharge. Proper precautions should be observed during handling, assembly and test.