

Silicon NPN Darlington Power Transistors

BD643

DESCRIPTION

- With TO-220C package
- Complement to type BD644
- DARLINGTON

APPLICATIONS

- For use in output stages in audio equipment ,general amplifier,and analogue switching applications

PINNING

PIN	DESCRIPTION
1	Base
2	Collector;connected to mounting base
3	Emitter

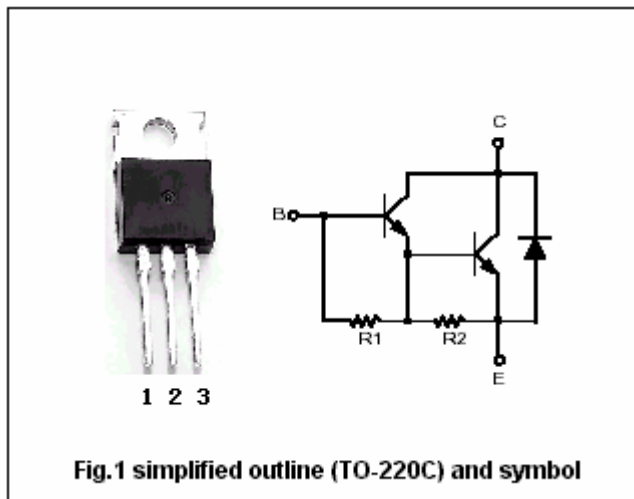

Absolute maximum ratings(Ta=25)

SYMBOL	PARAMETER	CONDITIONS	VALUE	UNIT
V_{CBO}	Collector-base voltage	Open emitter	45	V
V_{CEO}	Collector-emitter voltage	Open base	45	V
V_{EBO}	Emitter-base voltage	Open collector	5	V
I_C	Collector current-DC		8	A
I_{CM}	Collector current-Pulse		12	A
I_B	Base current		150	A
P_C	Collector power dissipation	$T_C=25$	62.5	W
T_j	Junction temperature		150	
T_{stg}	Storage temperature		-55~150	

THERMAL CHARACTERISTICS

SYMBOL	PARAMETER	MAX	UNIT
$R_{th\ j-c}$	Thermal resistance junction to case	1.5	/W

Silicon NPN Dalington Power Transistors

BD643

CHARACTERISTICS

T_j=25 unless otherwise specified

SYMBOL	PARAMETER	CONDITIONS	MIN	TYP.	MAX	UNIT
V _{(BR)CEO}	Collector-emitter breakdown voltage	I _C =0.1A, I _B =0	45			V
V _{(BR)CBO}	Collector-base breakdown voltage	I _C =5mA, I _E =0	45			V
V _{(BR)EBO}	Emitter-base breakdown voltage	I _E =2mA, I _C =0	5			V
V _{CEsat}	Collector-emitter saturation voltage	I _C =3A, I _B =12mA			2.0	V
V _{BE}	Base-emitter voltage	I _C =3A, V _{CE} =3V			2.5	V
I _{CBO}	Collector cut-off current	V _{CB} =V _{CBMax} ; I _E =0			0.2	mA
I _{CEO}	Collector cut-off current	V _{CE} =1/2 V _{CEMax} ; I _B =0			0.5	mA
I _{EBO}	Emitter cut-off current	V _{EB} =5V; I _C =0			5	mA
h _{FE-1}	DC current gain	I _C =0.5A; V _{CE} =3V		1500		
h _{FE-2}	DC current gain	I _C =3A; V _{CE} =3V	750			
h _{FE-3}	DC current gain	I _C =6A; V _{CE} =3V		750		
V _F	Diode forward voltage	I _F =3A		1.8		V
f _T	Transition frequency	I _C =3A; V _{CE} =3V; f=1MHz		7		MHz

Silicon NPN Dalington Power Transistors

BD643

PACKAGE OUTLINE

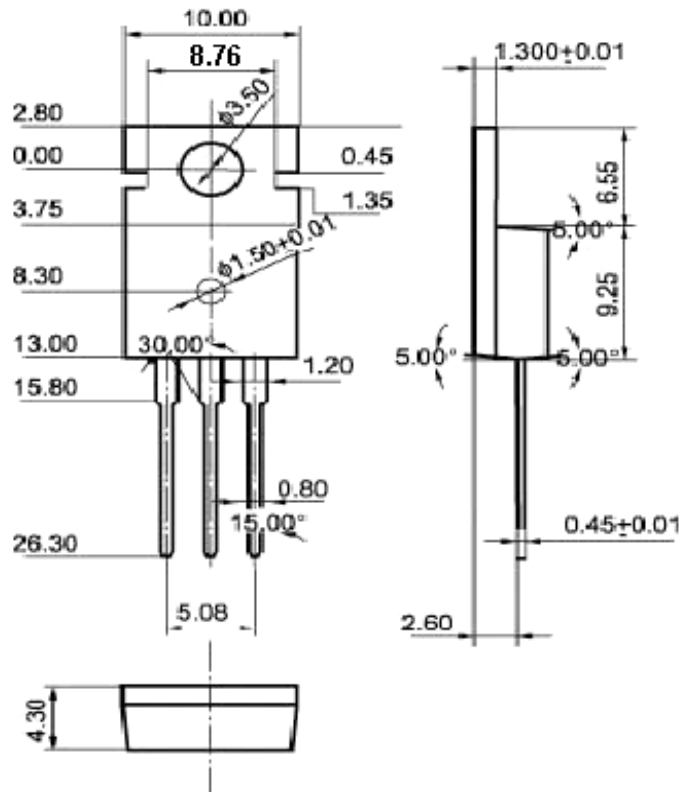

Fig.2 Outline dimensions