

Verpackt in Stangenprofil - *Tube Packaging*
 Verpackungseinheit: 19 Stück - *Packaging unit: 19 pcs*

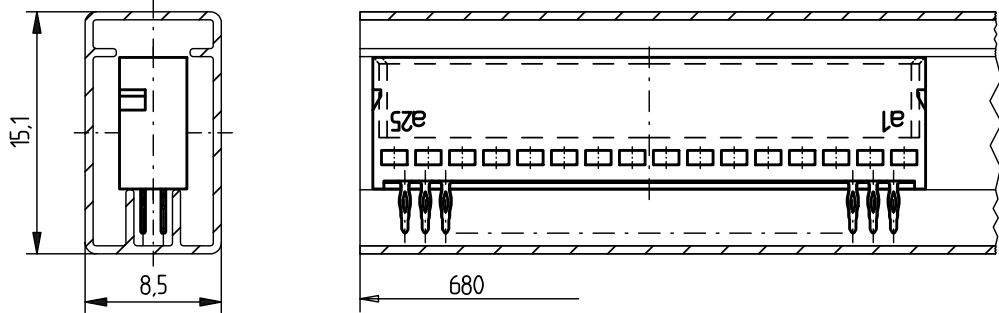

Schichtaufbau im metallisierten Loch für EE-Kontakt
Metal plating of plated-through hole for EE-contact

Lochbild für Leiterplatte
Board hole pattern

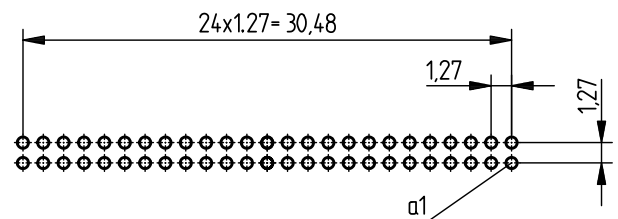
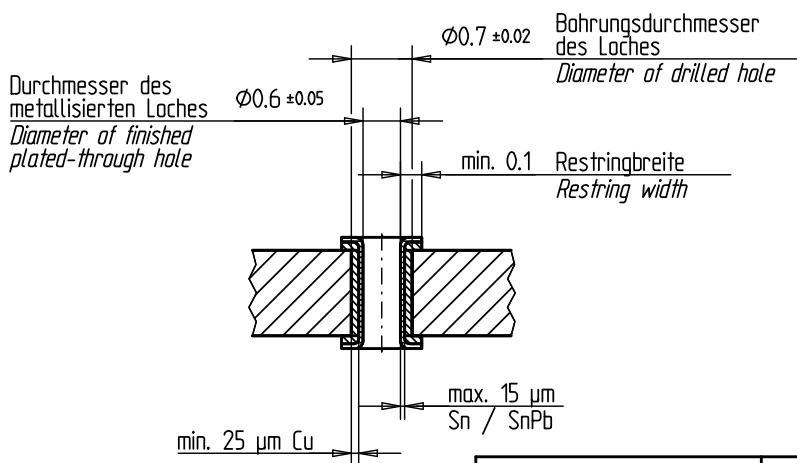

Anforderungsstufe 1
Performance Level 1
 Kontaktbereich vergoldet
Mating Area gold plating
 Anschlussbereich verzinkt 4-6 μm
Terminal Area 4-6 μm tin plating
 Koplranität der Anschlüsse $\leq 0.1\text{mm}$
Coplanarity Area of Termination $\leq 0.1\text{mm}$

Standard Bauhöhe
Standard Assembly Height

Information: All rights reserved. Only for information. To insure that this is the latest version of this drawing, please contact one of the ERNI companies before using.	Tolerances All Dimensions in mm	Scale 3:1	Designation Messerleiste SMC-Q, 50 polig Male Conn. SMC-Q, 50 contacts
	Subject to modification without prior notice. Drawing will not be updated.	www.ERNI.com	
Consider protection memo from DIN 34	18.05.2010 Date	Q-00069706.SZA	SMCQ