



Pb Free Plating Product

U1620RG thru U1660RG

16 Ampere Surface Mount Common Anode Ultra Fast Recovery Rectifier

Feature

- * Fast switching for high efficiency
- * Low forward voltage drop
- * High current capability
- * Low reverse leakage current
- * High surge current capability

Application

- * Automotive Inverters/Solar Inverters
- * Plating Power Supply, Adaptor, SMPS and UPS
- * Car Audio Amplifiers and Sound Device System

Mechanical Data

- * Case: TO-263/D2PAK pkg case
- * Epoxy: UL 94V-0 rate flame retardant
- * Terminals: Solderable per MIL-STD-202 method 208
- * Polarity: As marked on diode body
- * Mounting position: Any
- * Weight: 2.0 gram approximately

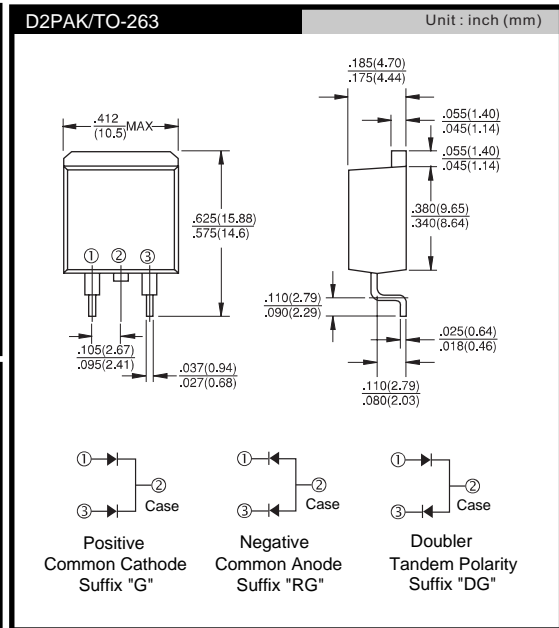

MAXIMUM RATINGS AND ELECTRICAL CHARACTERISTICS

Rating at 25°C ambient temperature unless otherwise specified.

Single phase, half wave, 60Hz, resistive or inductive load.

For capacitive load, derate current by 20%.

	SYMBOL	U1620RG	U1640RG	U1660RG	UNIT
Maximum Recurrent Peak Reverse Voltage	VRRM	200	400	600	V
Maximum RMS Voltage	VRMS	140	280	420	V
Maximum DC Blocking Voltage	VDC	200	400	600	V
Maximum Average Forward Rectified Current Tc=100°C	IF(AV)	16.0			A
Peak Forward Surge Current, 8.3ms single Half sine-wave superimposed on rated load (JEDEC method)	IFSM	175	150		A
Maximum Instantaneous Forward Voltage @ 8.0 A	VF	0.98	1.3	1.7	V
Maximum DC Reverse Current @TJ=25°C	IR	10.0			uA
At Rated DC Blocking Voltage @TJ=125°C		250			uA
Maximum Reverse Recovery Time (Note 1)	Trr	35			nS
Typical junction Capacitance (Note 2)	CJ	90			pF
Typical Thermal Resistance (Note 3)	RθJC	2.2			°C/W
Operating Junction and Storage Temperature Range	TJ, TSTG	-55 to + 150			°C

NOTES : (1) Reverse recovery test conditions IF = 0.5A, R = 1.0A, Irr = 0.25A.
 (2) Measured at 1.0 MHz and applied reverse voltage of 4.0 Volts DC.
 (3) Thermal Resistance junction to case.

FIG.1 - FORWARD CURRENT DERATING CURVE

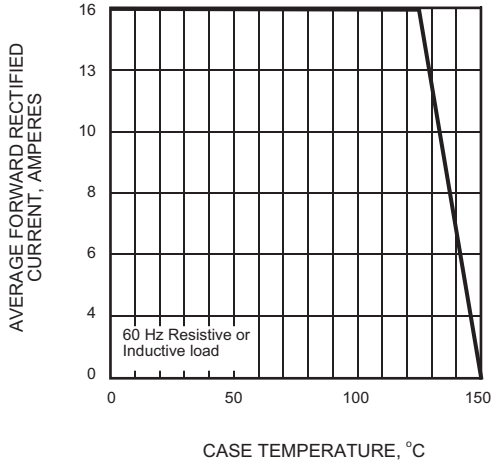

FIG.2 - MAXIMUM NON-REPETITIVE PEAK FORWARD SURGE CURRENT

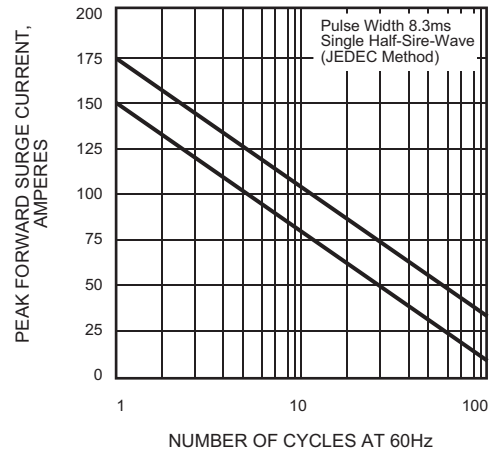

FIG.3 - TYPICAL INSTANTANEOUS FORWARD CHARACTERISTICS

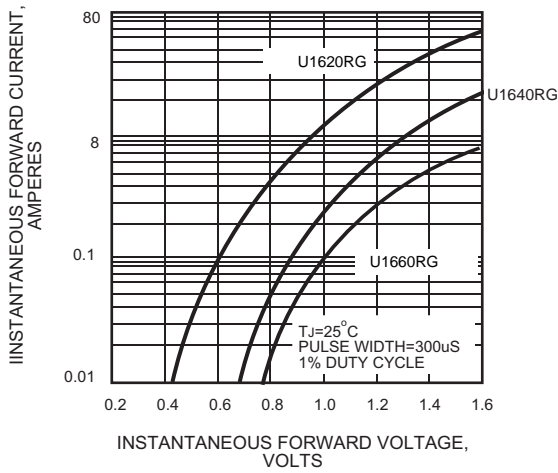

FIG.4 - TYPICAL REVERSE CHARACTERISTICS

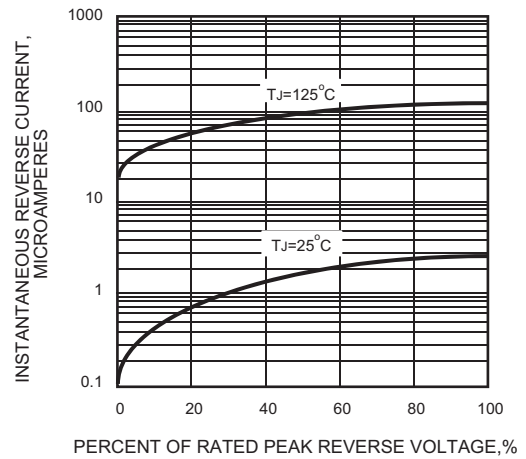

FIG.5 - TYPICAL JUNCTION CAPACITANCE

