

Variable X and Z have to be stated within the drawing number when an order is placed.

**Variable X= Coding**

coding X=	A	B	C	D
front view				
colour	deep black	cream white	signal blue	bordeaux violet
coding X=	E	F	G	H
front view				
colour	leaf green	nut brown	blue grey	heather violet
coding X=	I	K	L	M
front view				
colour	beige	curry yellow	carmine red	pastel orange
coding X=	N			
front view				
colour	pastel green			

**Variable Z= Plating**

Part	Material	Variable Z =		
		1	5	9
Plastic Housing	PA 6.6			
Centre contact	brass	Au	Au	Au
Outer Contact	brass	Au	white bronze	Ni
Insulator	PE			
Housing	diecast	Sn	Sn	Sn
Rest	stain. steel			

Bottom view

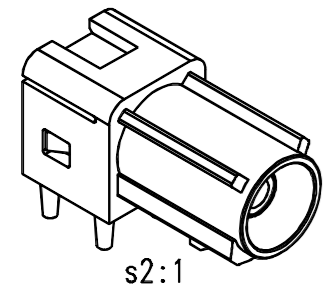
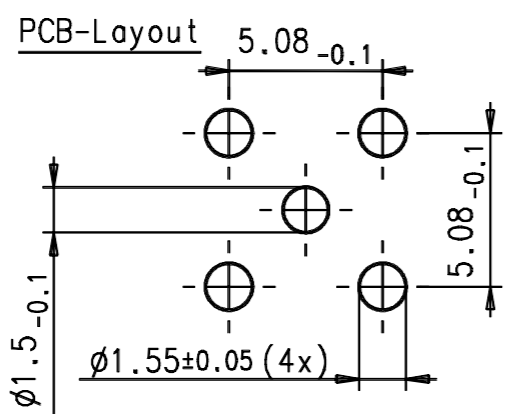
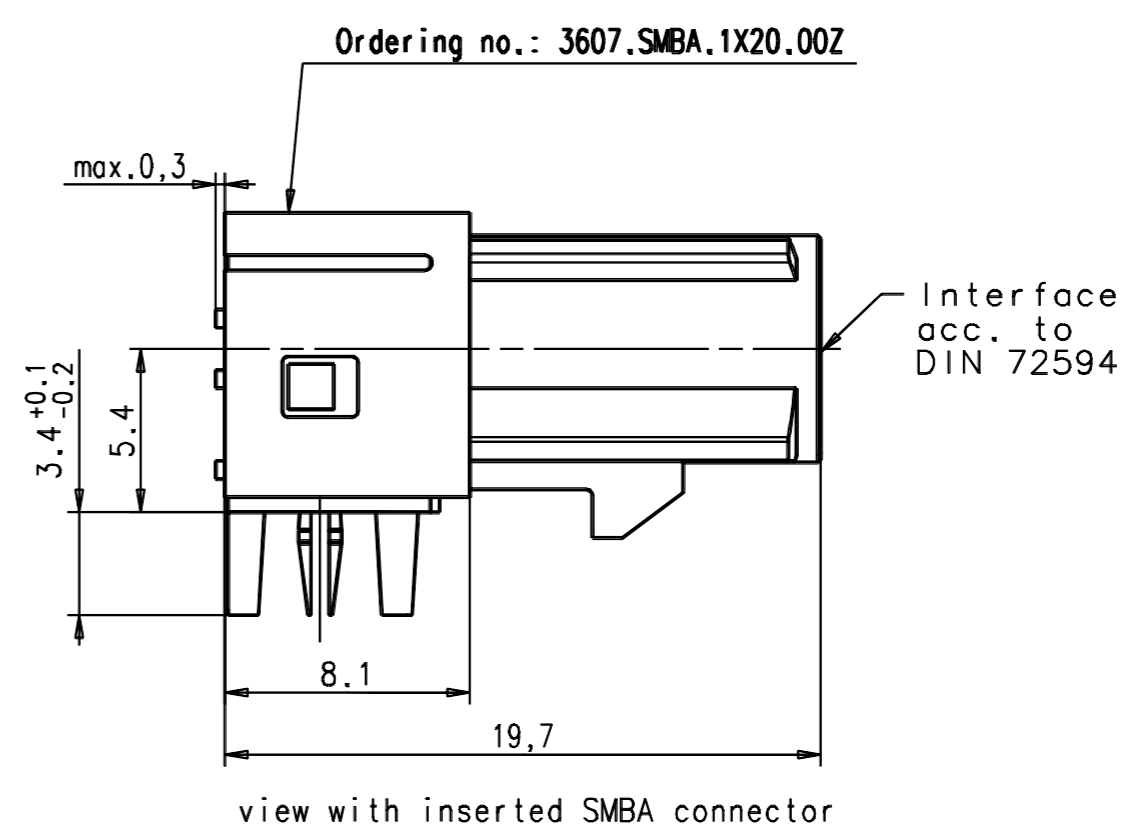
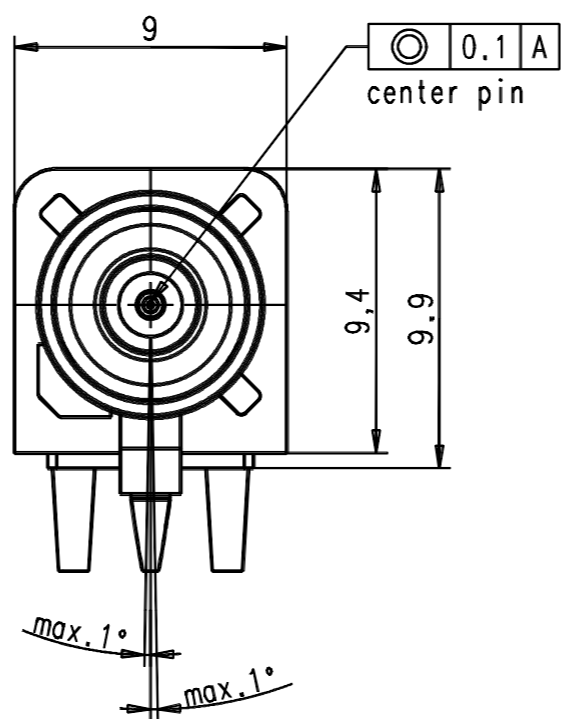
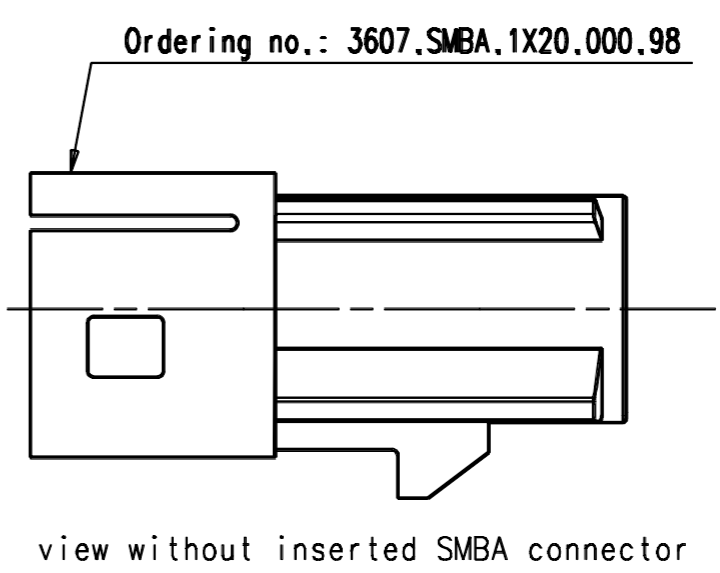
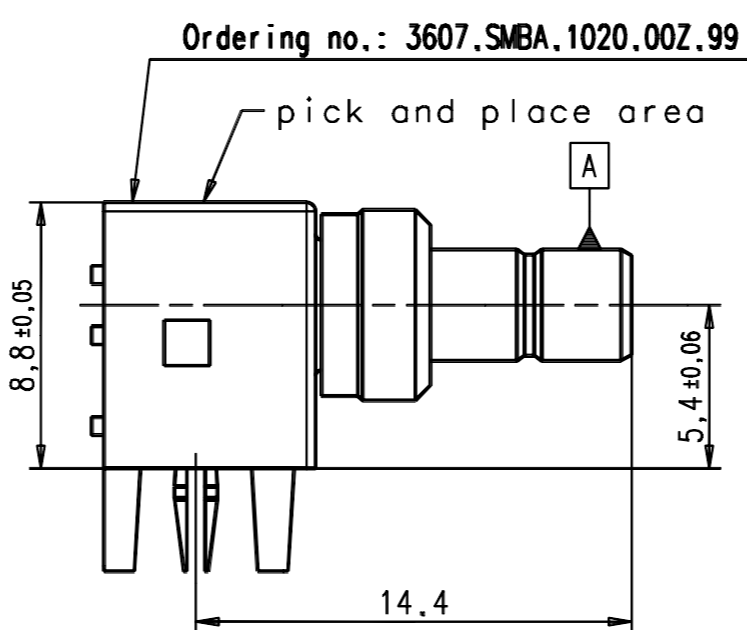
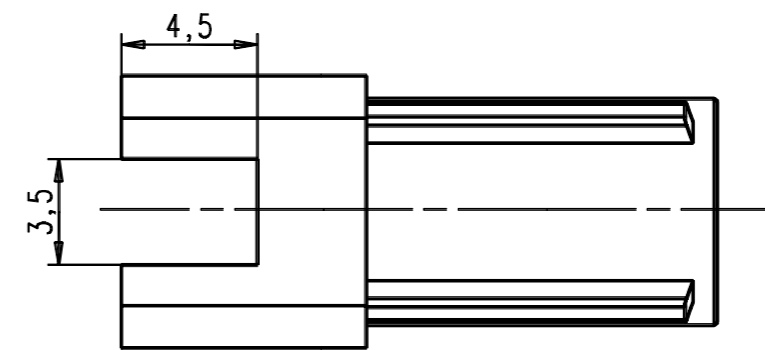
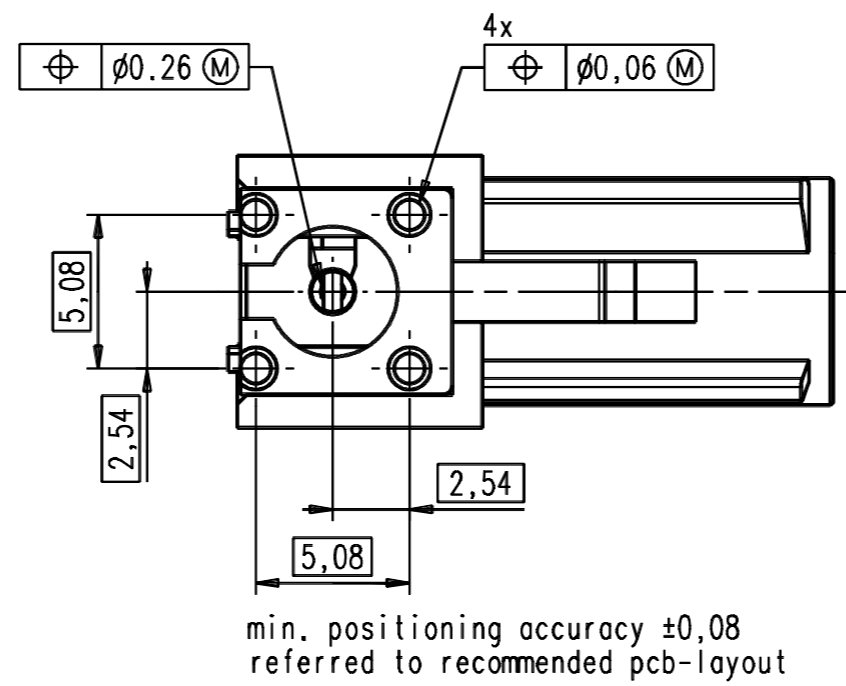

IMS CONNECTOR SYSTEMS		general tolerance		scale: 4:1 (2:2)	
		ISO 2768 mH		Assembly instruction:	
		DIN ISO 2692		Stripping dimension:	
507/03	l	Struktur	08.01.04	Glatz	
223/03	k	Position.-Toleranz	23.05.03	Glatz	generate
182/03	i	dimensions ad.	07.05.03	Glatz	checked
083/03	i	material table	04.03.03	Glatz	Norm
design	h	cor. acc. DIN72594	28.10.02	Glatz	38849
design	q	cor. acc. DIN72594	02.10.02	RSc	
design	f	text	17.09.02	Schuh	
design	e	length solderpins	12.07.02	Glatz	
nr.	rev.	alteration	date	name	
					Rev.