

# M5290P,FP

## ±5V TRACKING REGULATOR WITH RESET CIRCUIT

### DESCRIPTION

M5290 is a semiconductor integrated circuit designed for voltage regulator which is dual tracking type (positive/negative output voltage) with system reset circuit.

Since the output voltage is fixed inside, User can omit the outside resistors, and this IC includes the system reset circuit for detecting the abnormal status of Power Supply. When Power Supply of system is in abnormal status, this IC sends the system reset output (Low) to the MPU/CPU, so User can make the system operate safely.

### FEATURES

- High input voltage..... $V_I = \pm 20V$
- Fixed output voltage..... $V_O = \pm 5V$
- Internal system reset circuit (with hysteresis) detectable voltage.....4.2V (delay time is variable by connecting capacity at 7pin (6pin for the FP))
- Current limiting circuit, thermal protection circuit
- Capable of ON/OFF control (10pin)
- Very Low input-output voltage differential operation by using transistor
- Variable output voltage (with external resistors connected between terminals ⑩ and GND and between positive output terminals).

### APPLICATION

Dual power supply for CD players and stereo set pre-/main-amplifiers

### PIN CONFIGURATION (TOP VIEW)

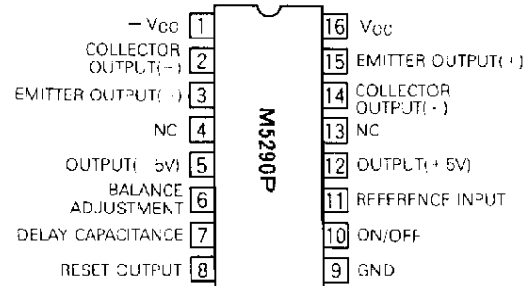

Outline 16P4

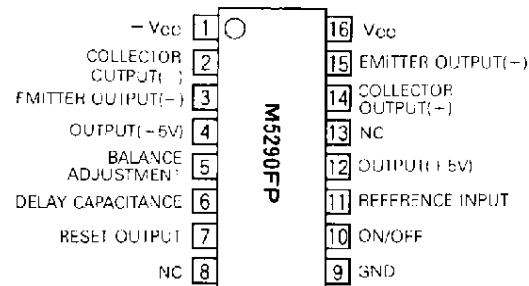

Outline 16P2S-A

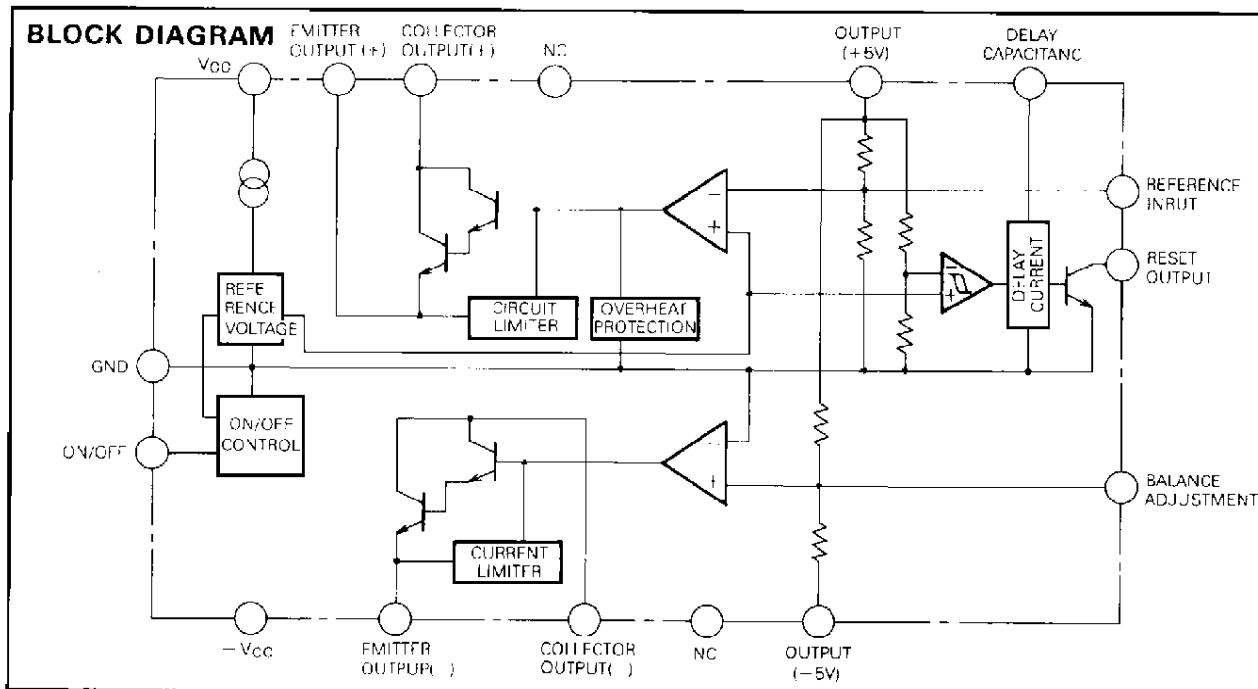

**±5V TRACKING REGULATOR WITH RESET CIRCUIT**

**ABSOLUTE MAXIMUM RATINGS** (Ta=25°C, unless otherwise noted)

| Symbol           | Parameter                       | Conditions | Ratings         | Unit  |
|------------------|---------------------------------|------------|-----------------|-------|
| V <sub>CC</sub>  | Supply voltage                  |            | ±20 (40)        | V     |
| I <sub>LP</sub>  | Load current                    |            | ±30             | mA    |
| V <sub>DIF</sub> | Input/Output Voltage difference |            | ±15 (30)        | V     |
| P <sub>d</sub>   | Power dissipation               |            | 1.0(P)/0.55(FP) | W     |
| K <sub>θ</sub>   | Thermal derating                | Ta ≥ 25°C  | 10.0(P)/5.5(FP) | mW/°C |
| T <sub>opr</sub> | Ambient temperature             |            | -20 ~ +75       | °C    |
| T <sub>stg</sub> | Storage temperature             |            | -55 ~ +125      | °C    |

**ELECTRICAL CHARACTERISTICS** (Ta=25°C, V<sub>CC</sub>=±8V, I<sub>L</sub>=±10mA, unless otherwise noted)

| Symbol          | Parameter       | Test condition | Limits |     |     | Unit |
|-----------------|-----------------|----------------|--------|-----|-----|------|
|                 |                 |                | MIN    | TYP | MAX |      |
| I <sub>CC</sub> | Circuit current |                | —      | 3.0 | 6.0 | mA   |

**REGULATOR PART**

| Symbol              | Parameter                 | Test conditions                   | Limits             |      |       | Unit  |
|---------------------|---------------------------|-----------------------------------|--------------------|------|-------|-------|
|                     |                           |                                   | MIN                | TYP  | MAX   |       |
| V <sub>IN</sub>     | Input voltage             |                                   | ±V <sub>O</sub> ±2 | —    | ±20   | V     |
| V <sub>O</sub>      | Output voltage            |                                   | +4.75              | ±5.0 | ±5.25 | V     |
| V <sub>REF</sub>    | Reference input voltage   |                                   | 1.15               | 1.20 | 1.25  | V     |
| ΔV <sub>O</sub>     | Dual voltage tracking     |                                   | —                  | 0.5  | 2     | %     |
| R.R                 | Ripple rejection          | C <sub>REF</sub> = 1μF, f = 120Hz | 50                 | 65   | —     | dB    |
| REG-IN              | Input voltage rejection   | V <sub>I</sub> = ±8 ~ ±18V        | —                  | 0.05 | 0.2   | %/V   |
| REG-IO              | Loading voltage rejection | I <sub>L0</sub> = 0 ~ 20mA        | —                  | 20   | 100   | mV    |
| V <sub>NO</sub>     | Output noise voltage      | f = 20Hz ~ 100kHz                 | —                  | 10   | —     | μVrms |
| V <sub>O(off)</sub> | Output cut-off voltage    | 10pin GND                         | —                  | —    | ±0.1  | V     |

**RESET PART**

| Symbol           | Parameter                 | Test conditions         | Limits |     |      | Unit |
|------------------|---------------------------|-------------------------|--------|-----|------|------|
|                  |                           |                         | MIN    | TYP | MAX  |      |
| V <sub>S</sub>   | Detected voltage          |                         | 3.95   | 4.2 | 4.45 | V    |
| ΔV <sub>S</sub>  | Hysteresis voltage        |                         | 50     | 100 | 300  | mV   |
| T <sub>pd</sub>  | Delay time                | C <sub>d</sub> = 0.1μF  | 3      | 7   | 14   | mS   |
| V <sub>sat</sub> | Output saturation voltage | I <sub>sink</sub> = 3mA | —      | 0.2 | 0.4  | V    |

Note: The employed measurement circuit conforms to application circuit example (1).

**±5V TRACKING REGULATOR WITH RESET CIRCUIT**

**APPLICATION EXAMPLE**

**1. Standard application example ( $I_L = \pm 30\text{mA}$ )**

**CREF**

Connection of this capacitor gives the following characteristics.

- 1 The rise time of the output voltage can be adjusted (slowed).
- 2 The ripple rejection ratio is improved.
- 3 Output noise voltage is reduced down to 1/10 of three terminal regulator IC.

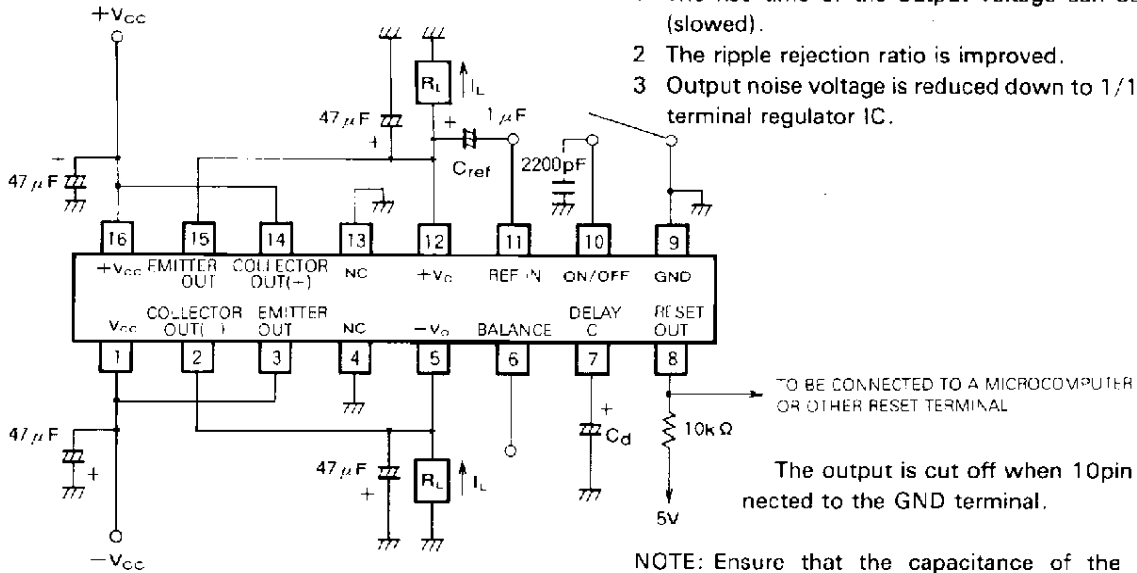

TO BE CONNECTED TO A MICROCOMPUTER OR OTHER RESET TERMINAL

The output is cut off when 10pin is connected to the GND terminal.

NOTE: Ensure that the capacitance of the employed capacitor does not significantly vary with the temperature.

**2. Very Low input-output voltage differential operation**

Stable operations are expected even if the input-output voltage. Differences are quite low as 0.2V.

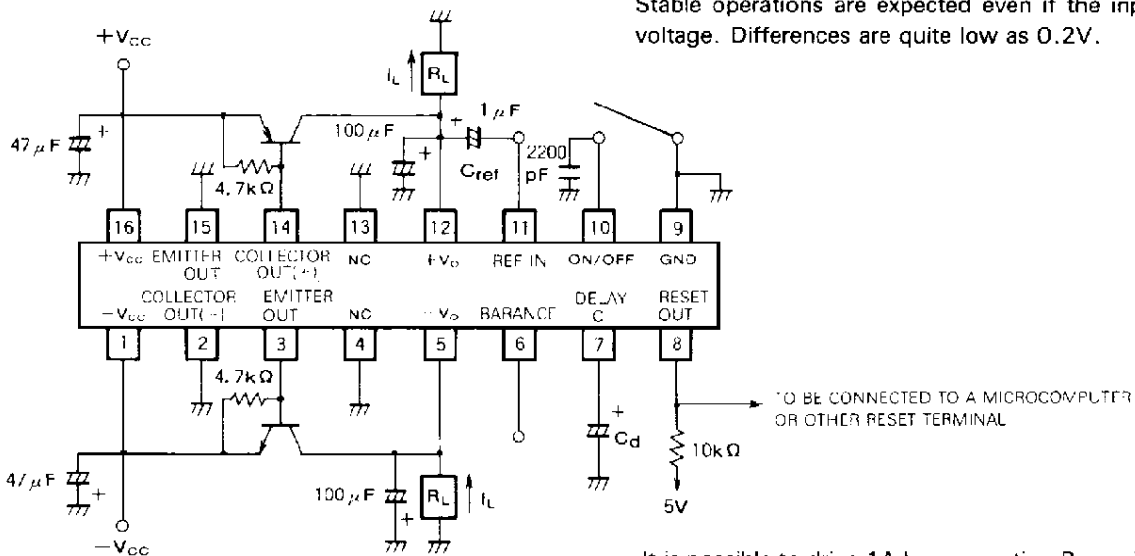

TO BE CONNECTED TO A MICROCOMPUTER OR OTHER RESET TERMINAL

It is possible to drive 1A by connecting Power Transistor. By shorting the 10pin to the GND, the output is shut down.

**±5V TRACKING REGULATOR WITH RESET CIRCUIT**

**(3) Foldback Protection Circuit Application  
Example (M5290P Foldback System)**

The input/output voltage differential  $V_{IO}$  should be adjusted to be high enough considering the voltage difference developed at  $R_1$ .

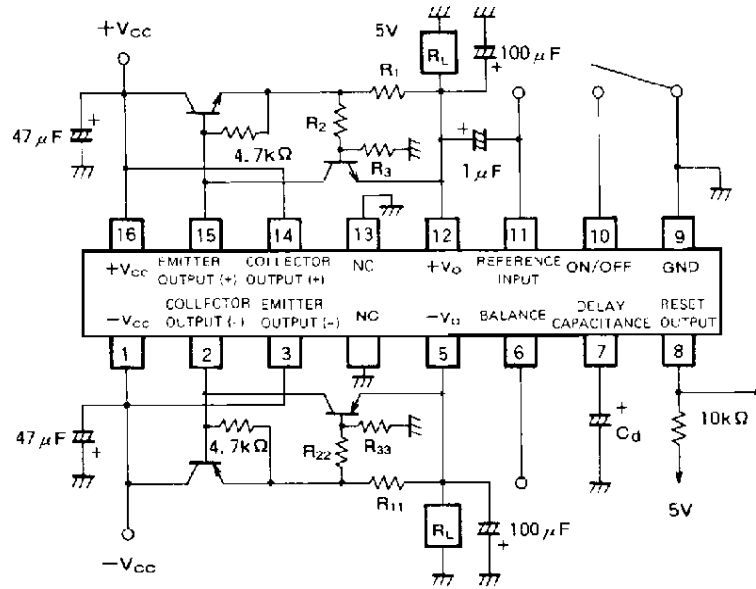

When two protective transistors are employed, the M5290P/FP can provide foldback characteristic for protection purposes. The  $I_1$  and  $I_2$  values are determined according to the external resistance.

$$I_1 \doteq \frac{R_2 + R_3}{R_1 \cdot R_3} \times 0.65 \text{ (A)}$$

$$I_2 \doteq I_1 + \frac{R_2}{R_1 \cdot R_3} \times 12 \text{ (A)}$$

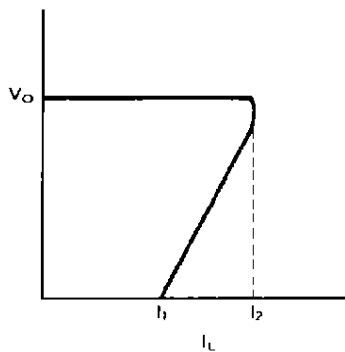

Cases where  $I_{L(PEAK)} = I_2 \approx 500\text{mA}$  and  $I_1 \approx 100\text{mA}$

$R_1 = R_{11} = 13\ \Omega$ ,  $R_2 = R_{22} = 2\text{k}\ \Omega$ ,  $R_3 = R_{33} = 2\text{k}\ \Omega$

The required input/output voltage differential is 8V or greater.

**±5V TRACKING REGULATOR WITH RESET CIRCUIT**

**ATTENTION**

**1. In adjusting the output voltage (use ⑪ pin)**

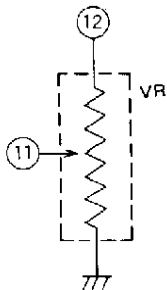

M5290P, FP is fixed the output voltage by inside resistors, but user can adjust it by using the outside resistor.  
(inside resistor: 2.4kΩ ⑪ to ⑨, 7.6kΩ ⑫ to ⑪)

**2. In adjusting the tracking voltage (use ⑥ pin (⑤ pin on FP))**

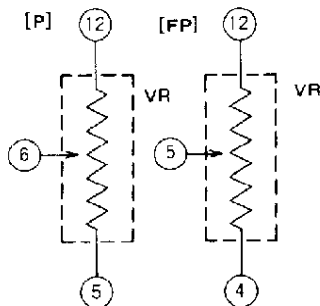

M5290P, FP is fixed the tracking voltage by inside resistor, but user can adjust it by using the output resistor.  
(inside resistor: ⑫ to ⑥ ⑥ to ⑤, 10kΩ for the M5290P )  
⑫ to ⑤ ⑤ to ④, 10kΩ for the M5290FP)

**3. Explaining figure of reset operation**

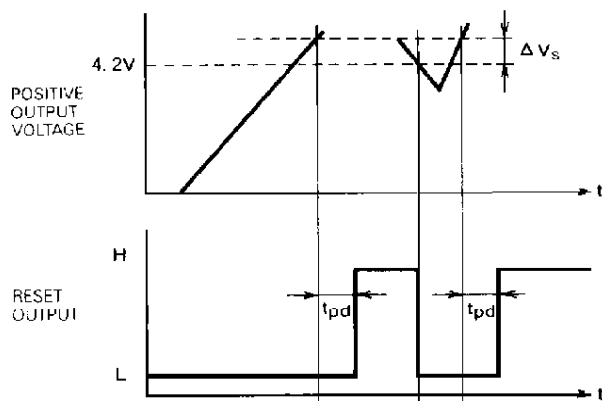

When the positive output voltage is normal, the Reset output is High.  
If it is lower than 4.2V, the Reset output is low.  
(delay time is variable by connecting capacity at 7pin (6pin for the FP))

$$t_{pd} = 7.0 \times 10^4 \times C (\text{sec})$$

C: delay time capacity