

# NCV8871

## Automotive Grade Non-Synchronous Boost Controller

The NCV8871 is an adjustable output non-synchronous boost controller which drives an external N-channel MOSFET. The device uses peak current mode control with internal slope compensation. The IC incorporates an internal regulator that supplies charge to the gate driver.

Protection features include internally-set soft-start, undervoltage lockout, cycle-by-cycle current limiting, hiccup-mode short-circuit protection and thermal shutdown.

Additional features include low quiescent current sleep mode and externally-synchronizable switching frequency.

### Features

- Peak Current Mode Control with Internal Slope Compensation
- 1.2 V  $\pm 2\%$  Reference voltage
- Fixed Frequency Operation
- Wide Input Voltage Range of 3.2 V to 40 Vdc, 45 V Load Dump
- Input Undervoltage Lockout (UVLO)
- Internal Soft-Start
- Low Quiescent Current in Sleep Mode
- Cycle-by-Cycle Current Limit Protection
- Hiccup-Mode Overcurrent Protection (OCP)
- Hiccup-Mode Short-Circuit Protection (SCP)
- Thermal Shutdown (TSD)
- This is a Pb-Free Device



ON Semiconductor®

<http://onsemi.com>



SOIC-8  
D SUFFIX  
CASE 751

### MARKING DIAGRAM

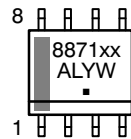

8871xx = Specific Device Code  
xx = 00, 01, 02, 03, 04  
A = Assembly Location  
L = Wafer Lot  
Y = Year  
W = Work Week  
▪ = Pb-Free Package

### PIN CONNECTIONS

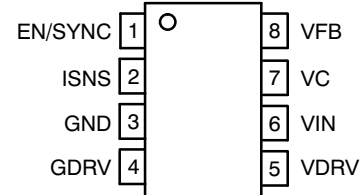

(Top View)

### ORDERING INFORMATION

Device	Package	Shipping†
NCV887100D1R2G	SOIC-8 (Pb-Free)	2500 / Tape & Reel
NCV887101D1R2G	SOIC-8 (Pb-Free)	2500 / Tape & Reel
NCV887102D1R2G	SOIC-8 (Pb-Free)	2500 / Tape & Reel
NCV887103D1R2G	SOIC-8 (Pb-Free)	2500 / Tape & Reel
NCV887104D1R2G	SOIC-8 (Pb-Free)	2500 / Tape & Reel

†For information on tape and reel specifications, including part orientation and tape sizes, please refer to our Tape and Reel Packaging Specification Brochure, BRD8011/D.

# NCV8871

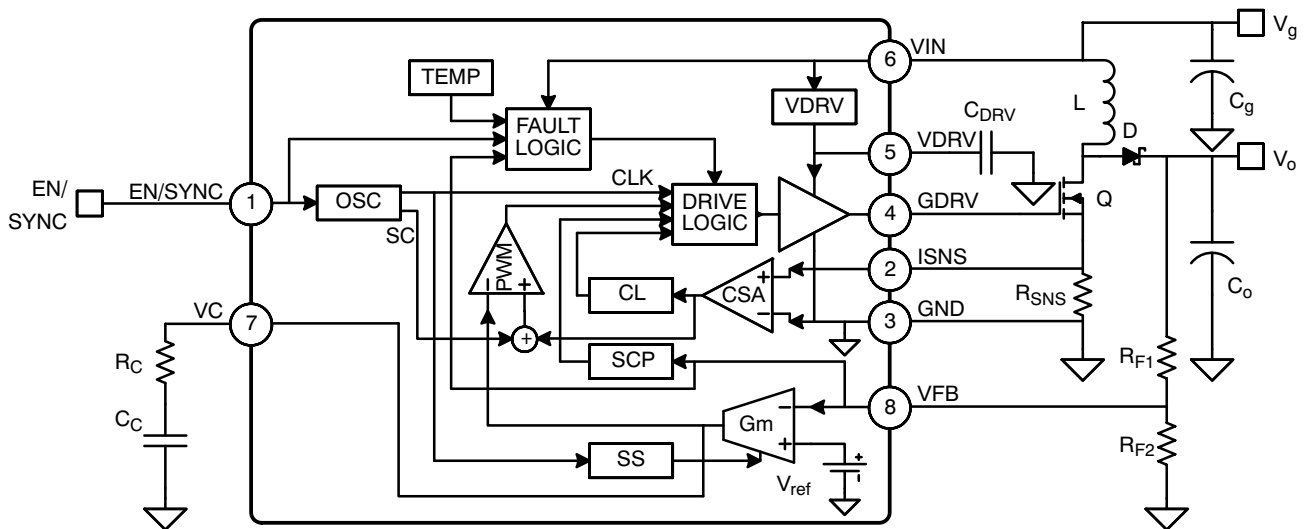

Figure 1. Simplified Block Diagram and Application Schematic

## PACKAGE PIN DESCRIPTIONS

Pin No.	Pin Symbol	Function
1	EN/SYNC	Enable and synchronization input. The falling edge synchronizes the internal oscillator. The part is disabled into sleep mode when this pin is brought low for longer than the enable time-out period.
2	ISNS	Current sense input. Connect this pin to the source of the external N-MOSFET, through a current-sense resistor to ground to sense the switching current for regulation and current limiting.
3	GND	Ground reference.
4	GDRV	Gate driver output. Connect to gate of the external N-MOSFET. A series resistance can be added from GDRV to the gate to tailor EMC performance.
5	VDRV	Driving voltage. Internally-regulated supply for driving the external N-MOSFET, sourced from VIN. Bypass with a 1.0 $\mu$ F ceramic capacitor to ground.
6	VIN	Input voltage. If bootstrapping operation is desired, connect a diode from the input supply to VIN, in addition to a diode from the output voltage to VDRV and/or VIN.
7	VC	Output of the voltage error amplifier. An external compensator network from VC to GND is used to stabilize the converter.
8	VFB	Output voltage feedback. A resistor from the output voltage to VFB with another resistor from VFB to GND creates a voltage divider for regulation and programming of the output voltage.

# NCV8871

## ABSOLUTE MAXIMUM RATINGS (Voltages are with respect to GND, unless otherwise indicated)

Rating	Value	Unit
Dc Supply Voltage (VIN)	-0.3 to 40	V
Peak Transient Voltage (Load Dump on VIN)	45	V
Dc Supply Voltage (VDRV, GDRV)	12	V
Peak Transient Voltage (VFB)	-0.3 to 6	V
Dc Voltage (VC, VFB, ISNS)	-0.3 to 3.6	V
Dc Voltage (EN/SYNC)	-0.3 to 6	V
Dc Voltage Stress (VIN - VDRV)*	-0.7 to 45	V
Operating Junction Temperature	-40 to 150	°C
Storage Temperature Range	-65 to 150	°C
Peak Reflow Soldering Temperature: Pb-Free, 60 to 150 seconds at 217°C	265 peak	°C

Stresses exceeding Maximum Ratings may damage the device. Maximum Ratings are stress ratings only. Functional operation above the Recommended Operating Conditions is not implied. Extended exposure to stresses above the Recommended Operating Conditions may affect device reliability.

\*An external diode from the input to the VIN pin is required if bootstrapping VDRV and VIN off of the output voltage.

## PACKAGE CAPABILITIES

Characteristic	Value	Unit	
ESD Capability (All Pins)	Human Body Model Machine Model	≥ 2.0 ≥ 200	kV V
Moisture Sensitivity Level	1	-	
Package Thermal Resistance	Junction-to-Ambient, R <sub>θJA</sub> (Note 1)	100	°C/W

1. 1 in<sup>2</sup>, 1 oz copper area used for heatsinking.

## Device Variations

The NCV8871 features several variants to better fit a multitude of applications. The table below shows the typical values of parameters for the parts that are currently available.

## TYPICAL VALUES

Part No.	D <sub>max</sub>	f <sub>s</sub>	t <sub>ss</sub>	S <sub>a</sub>	V <sub>cl</sub>	I <sub>src</sub>	I <sub>sink</sub>	V <sub>DRV</sub>	SCE
NCV887100	88%	170 kHz	7.4 ms	53 mV/μs	400 mV	800 mA	600 mA	10.5 V	Y
NCV887101	86%	1000 kHz	1.25 ms	16 mV/μs	400 mV	575 mA	350 mA	6.3 V	Y
NCV887102	91%	1000 kHz	1.25 ms	53 mV/μs	400 mV	800 mA	600 mA	6.3 V	N
NCV887103	93%	340 kHz	3.7 ms	53 mV/μs	200 mV	575 mA	350 mA	8.4 V	Y
NCV887104	93%	340 kHz	3.7 ms	53 mV/μs	200 mV	800 mA	600 mA	8.4 V	N

## DEFINITIONS

Symbol	Characteristic	Symbol	Characteristic	Symbol	Characteristic
D <sub>max</sub>	Maximum Duty Cycle	f <sub>s</sub>	Switching Frequency	t <sub>ss</sub>	Soft-Start Time
S <sub>a</sub>	Slope Compensating Ramp	V <sub>cl</sub>	Current Limit Trip Voltage	I <sub>src</sub>	Gate Drive Sourcing Current
I <sub>sink</sub>	Gate Drive Sinking Current	V <sub>DRV</sub>	Drive Voltage	SCE	Short Circuit Enable

# NCV8871

**ELECTRICAL CHARACTERISTICS** ( $-40^{\circ}\text{C} < T_J < 150^{\circ}\text{C}$ ,  $3.2\text{ V} < V_{\text{IN}} < 40\text{ V}$ , unless otherwise specified) Min/Max values are guaranteed by test, design or statistical correlation.

Characteristic	Symbol	Conditions	Min	Typ	Max	Unit
<b>GENERAL</b>						
Quiescent Current, Sleep Mode	$I_{q,\text{sleep}}$	$V_{\text{IN}} = 13.2\text{ V}$ , $\text{EN} = 0$ , $T_J = 25^{\circ}\text{C}$	–	2.0	–	$\mu\text{A}$
Quiescent Current, Sleep Mode	$I_{q,\text{sleep}}$	$V_{\text{IN}} = 13.2\text{ V}$ , $\text{EN} = 0$ , $-40^{\circ}\text{C} < T_J < 125^{\circ}\text{C}$	–	2.0	6.0	$\mu\text{A}$
Quiescent Current, No switching	$I_{q,\text{off}}$	Into $V_{\text{IN}}$ pin, $\text{EN} = 1$ , No switching	–	1.5	2.5	$\text{mA}$
Quiescent Current, Switching, normal operation	$I_{q,\text{on}}$	Into $V_{\text{IN}}$ pin, $\text{EN} = 1$ , Switching	–	3.0	6.0	$\text{mA}$

## OSCILLATOR

Minimum pulse width	$t_{\text{on,min}}$		90	115	140	ns
Maximum duty cycle	$D_{\text{max}}$	NCV887100 NCV887101 NCV887102 NCV887103 NCV887104	86 84 89 91 91	88 86 91 93 93	90 88 93 95 95	%
Switching frequency	$f_s$	NCV887100 NCV887101 NCV887102 NCV887103 NCV887104	153 900 900 306 306	170 1000 1000 340 340	187 1100 1100 374 374	kHz
Soft-start time	$t_{\text{ss}}$	From start of switching with $V_{\text{FB}} = 0$ until reference voltage = $V_{\text{REF}}$ NCV887100 NCV887101 NCV887102 NCV887103 NCV887104	6.0 1.0 1.0 3.0 3.0	7.4 1.25 1.25 3.7 3.7	8.8 1.5 1.5 4.4 4.4	ms
Soft-start delay	$t_{\text{ss,dly}}$	From $\text{EN} \rightarrow 1$ until start of switching with $V_{\text{FB}} = 0$	–	240	280	$\mu\text{s}$
Slope compensating ramp	$S_a$	NCV887100 NCV887101 NCV887102 NCV887103 NCV887104	46 13 46 46 46	53 16 53 53 53	60 19 60 60 60	$\text{mV}/\mu\text{s}$

## ENABLE/SYNCHRONIZATION

EN/SYNC pull-down current	$I_{\text{EN/SYNC}}$	$V_{\text{EN/SYNC}} = 5\text{ V}$	–	5.0	10	$\mu\text{A}$
EN/SYNC input high voltage	$V_{s,\text{ih}}$		2.0	–	5.0	V
EN/SYNC input low voltage	$V_{s,\text{il}}$		0	–	800	mV
EN/SYNC time-out ratio	$\%t_{\text{en}}$	From SYNC falling edge, to oscillator control (EN high) or shutdown (EN low), Percent of typical switching period	–	–	350	%
SYNC minimum frequency ratio	$\%f_{\text{sync,min}}$	Percent of $f_s$	–	–	80	%
SYNC maximum frequency	$f_{\text{sync,max}}$		1.1	–	–	MHz
Synchronization delay	$t_{s,\text{dly}}$	From SYNC falling edge to GDRV falling edge	–	50	100	ns
Synchronization duty cycle	$D_{\text{sync}}$		25	–	75	%

## CURRENT SENSE AMPLIFIER

Low-frequency gain	$A_{\text{csa}}$	Input-to-output gain at dc, $\text{ISNS} \leq 1\text{ V}$	0.9	1.0	1.1	V/V
Bandwidth	$\text{BW}_{\text{csa}}$	Gain of $A_{\text{csa}} - 3\text{ dB}$	2.5	–	–	MHz
ISNS input bias current	$I_{\text{sns,bias}}$	Out of ISNS pin	–	30	50	$\mu\text{A}$

# NCV8871

**ELECTRICAL CHARACTERISTICS** ( $-40^{\circ}\text{C} < T_J < 150^{\circ}\text{C}$ ,  $3.2\text{ V} < V_{\text{IN}} < 40\text{ V}$ , unless otherwise specified) Min/Max values are guaranteed by test, design or statistical correlation.

Characteristic	Symbol	Conditions	Min	Typ	Max	Unit
----------------	--------	------------	-----	-----	-----	------

## CURRENT SENSE AMPLIFIER

Current limit threshold voltage	$V_{\text{cl}}$	Voltage on ISNS pin NCV887100 NCV887101 NCV887102 NCV887103 NCV887104	360 360 360 180 180	400 400 400 200 200	440 440 440 220 220	mV
Current limit, Response time	$t_{\text{cl}}$	CL tripped until GDRV falling edge, $V_{\text{ISNS}} = V_{\text{cl}} + 40\text{ mV}$	-	80	125	ns
Overcurrent protection, Threshold voltage	$\%V_{\text{ocp}}$	Percent of $V_{\text{cl}}$	125	150	175	%
Overcurrent protection, Response Time	$t_{\text{ocp}}$	From overcurrent event, Until switching stops, $V_{\text{ISNS}} = V_{\text{OCP}} + 40\text{ mV}$	-	-	125	ns

## VOLTAGE ERROR OPERATIONAL TRANSCONDUCTANCE AMPLIFIER

Transconductance	$g_{\text{m,vea}}$	$V_{\text{FB}} - V_{\text{ref}} = \pm 20\text{ mV}$	0.8	1.2	1.5	mS
VEA output resistance	$R_{\text{o,vea}}$		2.0	-	-	M $\Omega$
VFB input bias current	$I_{\text{vfb,bias}}$	Current out of VFB pin	-	0.5	2.0	$\mu\text{A}$
Reference voltage	$V_{\text{ref}}$		1.176	1.200	1.224	V
VEA maximum output voltage	$V_{\text{c,max}}$		2.5	-	-	V
VEA minimum output voltage	$V_{\text{c,min}}$		-	-	0.3	V
VEA sourcing current	$I_{\text{src,vea}}$	VEA output current, $V_{\text{c}} = 2.0\text{ V}$	80	100	-	$\mu\text{A}$
VEA sinking current	$I_{\text{snk,vea}}$	VEA output current, $V_{\text{c}} = 0.7\text{ V}$	80	100	-	$\mu\text{A}$

## GATE DRIVER

Sourcing current	$I_{\text{src}}$	$V_{\text{DRV}} \geq 6\text{ V}$ , $V_{\text{DRV}} - V_{\text{GDRV}} = 2\text{ V}$ NCV887100 NCV887101 NCV887102 NCV887103 NCV887104	600 400 600 400 600	800 575 800 575 800	- - - - -	mA
Sinking current	$I_{\text{sink}}$	$V_{\text{GDRV}} \geq 2\text{ V}$ NCV887100 NCV887101 NCV887102 NCV887103 NCV887104	500 250 500 250 500	600 350 600 350 600	- - - - -	mA
Driving voltage dropout	$V_{\text{drv,do}}$	$V_{\text{IN}} - V_{\text{DRV}}$ , $I_{\text{DRV}} = 25\text{ mA}$	-	0.3	0.6	V
Driving voltage source current	$I_{\text{drv}}$	$V_{\text{IN}} - V_{\text{DRV}} = 1\text{ V}$	35	45	-	mA
Backdrive diode voltage drop	$V_{\text{d,bd}}$	$V_{\text{DRV}} - V_{\text{IN}}$ , $I_{\text{d,bd}} = 5\text{ mA}$	-	-	0.7	V
Driving voltage	$V_{\text{DRV}}$	$I_{\text{DRV}} = 0.1 - 25\text{ mA}$ NCV887100 NCV887101 NCV887102 NCV887103 NCV887104	10 6.0 6.0 8.0 8.0	10.5 6.3 6.3 8.4 8.4	11 6.6 6.6 8.8 8.8	V

## UVLO

Undervoltage lock-out, Threshold voltage	$V_{\text{uvlo}}$	$V_{\text{IN}}$ falling	3.0	3.1	3.2	V
Undervoltage lock-out, Hysteresis	$V_{\text{uvlo,hys}}$	$V_{\text{IN}}$ rising	50	125	200	mV

# NCV8871

**ELECTRICAL CHARACTERISTICS** ( $-40^{\circ}\text{C} < T_J < 150^{\circ}\text{C}$ ,  $3.2\text{ V} < V_{\text{IN}} < 40\text{ V}$ , unless otherwise specified) Min/Max values are guaranteed by test, design or statistical correlation.

Characteristic	Symbol	Conditions	Min	Typ	Max	Unit
----------------	--------	------------	-----	-----	-----	------

## SHORT CIRCUIT PROTECTION

Startup blanking period	$\%t_{\text{scp,dly}}$	From start of soft-start, Percent of $t_{\text{ss}}$	100	120	150	%
Hiccup-mode period	$\%t_{\text{hcp,dly}}$	From shutdown to start of soft-start, Percent of $t_{\text{ss}}$	70	85	100	%
Short circuit threshold voltage	$\%V_{\text{scp}}$	$V_{\text{FB}}$ as percent of $V_{\text{ref}}$	60	67	75	%
Short circuit delay	$t_{\text{scp}}$	From $V_{\text{FB}} < V_{\text{scp}}$ to stop switching	-	35	100	ns

## THERMAL SHUTDOWN

Thermal shutdown threshold	$T_{\text{sd}}$	$T_J$ rising	160	170	180	$^{\circ}\text{C}$
Thermal shutdown hysteresis	$T_{\text{sd,hys}}$	$T_J$ falling	10	15	20	$^{\circ}\text{C}$
Thermal shutdown delay	$t_{\text{sd,dly}}$	From $T_J > T_{\text{sd}}$ to stop switching	-	-	100	ns

TYPICAL PERFORMANCE CHARACTERISTICS

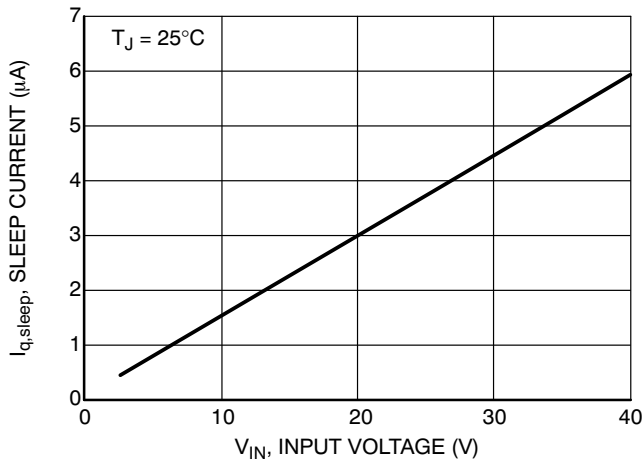

Figure 2. Sleep Current vs. Input Voltage

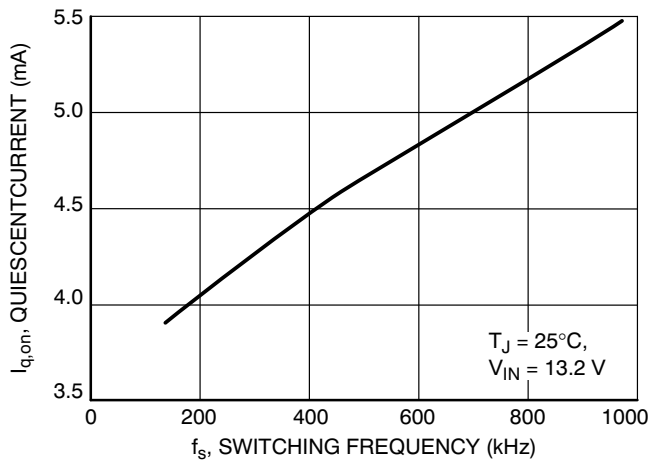

Figure 3. Quiescent Current vs. Switching Frequency

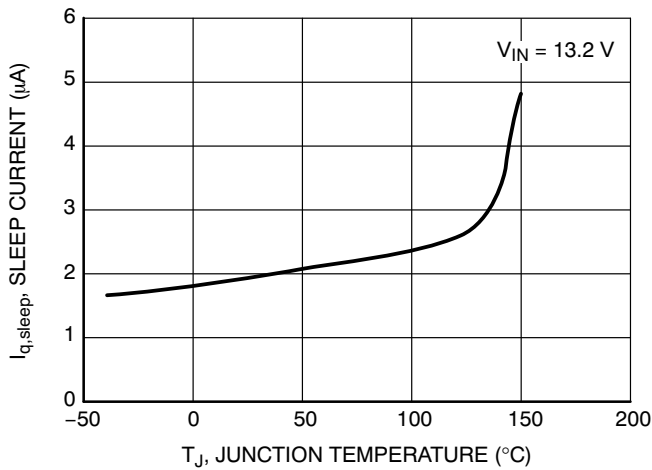

Figure 4. Sleep Current vs. Temperature

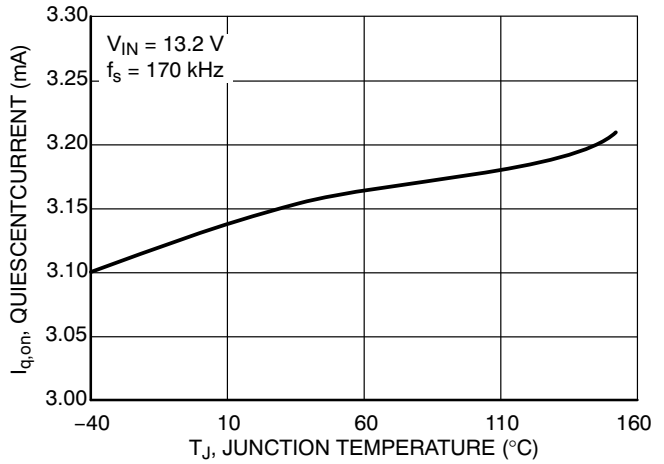

Figure 5. Quiescent Current vs. Temperature

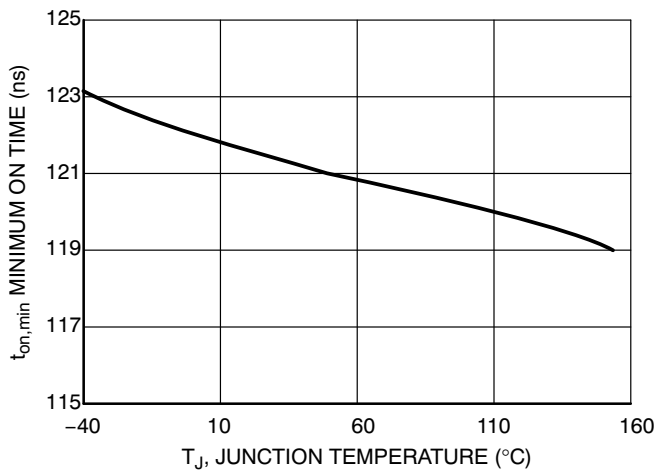

Figure 6. Minimum On Time vs. Temperature

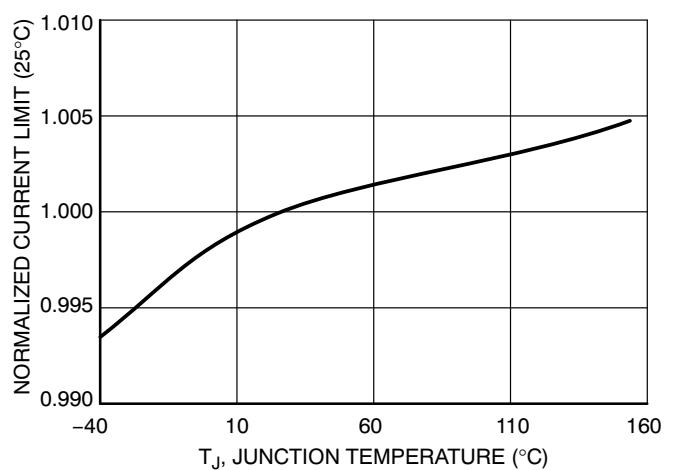

Figure 7. Normalized Current Limit vs. Temperature

TYPICAL PERFORMANCE CHARACTERISTICS

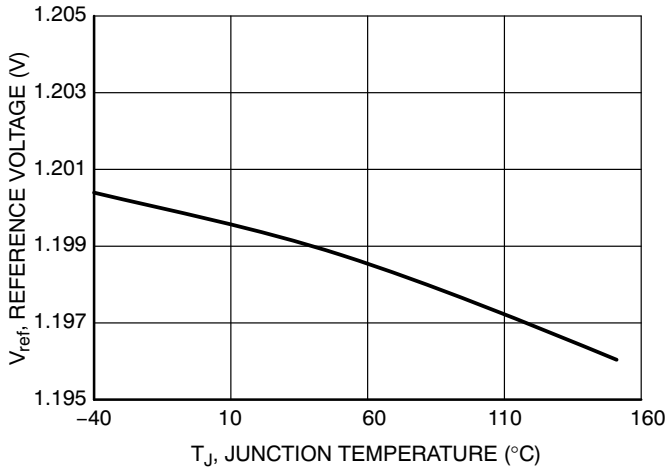

Figure 8. Reference Voltage vs. Temperature

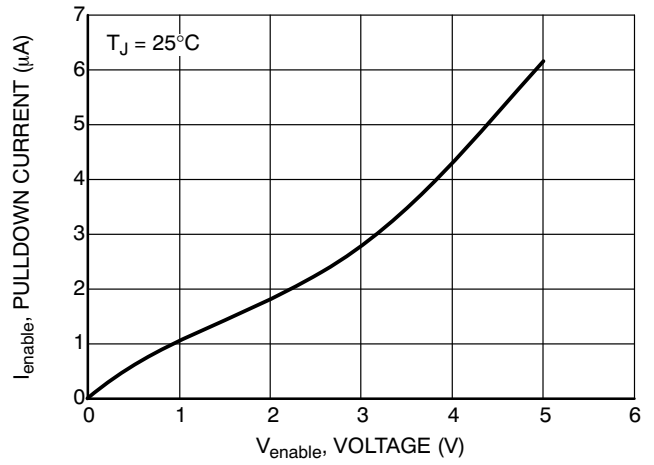

Figure 9. Enable Pulldown Current vs. Voltage

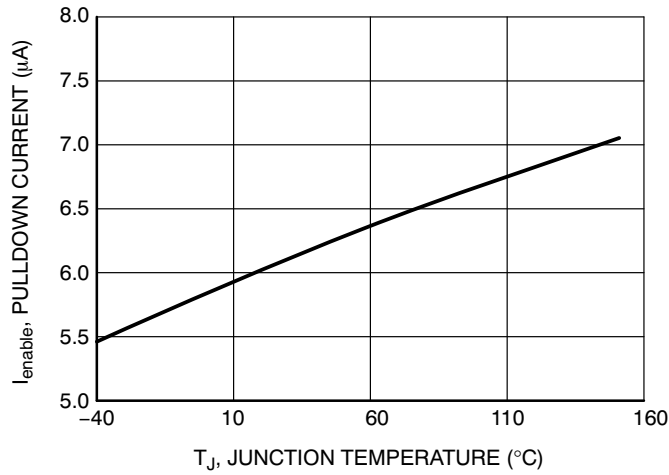

Figure 10. Enable Pulldown Current vs. Temperature



THEORY OF OPERATION

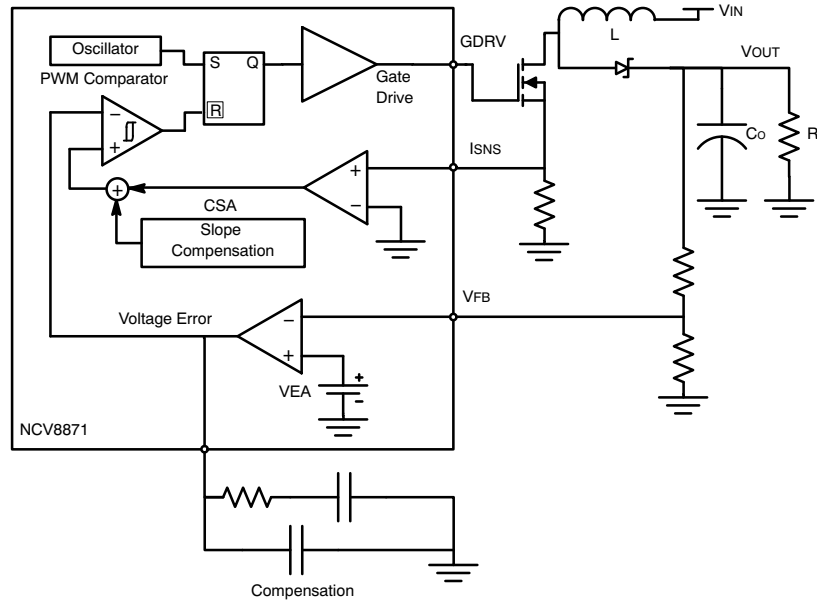

Figure 11. Current Mode Control Schematic

**Current Mode Control**

The NCV8871 incorporates a current mode control scheme, in which the PWM ramp signal is derived from the power switch current. This ramp signal is compared to the output of the error amplifier to control the on-time of the power switch. The oscillator is used as a fixed-frequency clock to ensure a constant operational frequency. The resulting control scheme features several advantages over conventional voltage mode control. First, derived directly from the inductor, the ramp signal responds immediately to line voltage changes. This eliminates the delay caused by the output filter and the error amplifier, which is commonly found in voltage mode controllers. The second benefit comes from inherent pulse-by-pulse current limiting by merely clamping the peak switching current. Finally, since current mode commands an output current rather than voltage, the filter offers only a single pole to the feedback loop. This allows for a simpler compensation.

The NCV8871 also includes a slope compensation scheme in which a fixed ramp generated by the oscillator is added to the current ramp. A proper slope rate is provided to improve circuit stability without sacrificing the advantages of current mode control.

**Current Limit**

The NCV8871 features two current limit protections, peak current mode and over current latch off. When the current sense amplifier detects a voltage above the peak current limit between ISNS and GND after the current limit leading edge blanking time, the peak current limit causes the power switch to turn off for the remainder of the cycle. Set the current limit with a resistor from ISNS to GND, with  $R = V_{CL} / I_{limit}$ .

If the voltage across the current sense resistor exceeds the over current threshold voltage the device enters over current hiccup mode. The device will remain off for the hiccup time and then go through the soft-start procedure.

**Short Circuit Protection**

If the short circuit enable bit is set (SCE = Y) the device will attempt to protect the power MOSFET from damage. When the output voltage falls below the short circuit trip voltage, after the initial short circuit blanking time, the device enters short circuit latch off. The device will remain off for the hiccup time and then go through the soft-start.

**EN/SYNC**

The Enable/Synchronization pin has three modes. When a dc logic high (CMOS/TTL compatible) voltage is applied to this pin the NCV8871 operates at the programmed frequency. When a dc logic low voltage is applied to this pin the NCV8871 enters a low quiescent current sleep mode. When a square wave of at least  $\%f_{sync,min}$  of the free running switching frequency is applied to this pin, the switcher operates at the same frequency as the square wave. If the signal is slower than this, it will be interpreted as enabling and disabling the part. The falling edge of the square wave corresponds to the start of the switching cycle. If device is disabled, it must be disabled for 7 clock cycles before being re-enabled.

**UVLO**

Input Undervoltage Lockout (UVLO) is provided to ensure that unexpected behavior does not occur when VIN is too low to support the internal rails and power the controller. The IC will start up when enabled and VIN surpasses the UVLO threshold plus the UVLO hysteresis

and will shut down when VIN drops below the UVLO threshold or the part is disabled.

**Internal Soft-Start**

To insure moderate inrush current and reduce output overshoot, the NCV8871 features a soft start which charges a capacitor with a fixed current to ramp up the reference voltage. This fixed current is based on the switching frequency, so that if the NCV8871 is synchronized to twice the default switching frequency the soft start will last half as long.

**VDRV**

An internal regulator provides the drive voltage for the gate driver. Bypass with a ceramic capacitor to ground to ensure fast turn on times. The capacitor should be between 0.1 μF and 1 μF, depending on switching speed and charge requirements of the external MOSFET.

**APPLICATION INFORMATION**

**Design Methodology**

This section details an overview of the component selection process for the NCV8871 in continuous conduction mode boost. It is intended to assist with the design process but does not remove all engineering design work. Many of the equations make heavy use of the small ripple approximation. This process entails the following steps:

1. Define Operational Parameters
2. Select Current Sense Resistor
3. Select Output Inductor
4. Select Output Capacitors
5. Select Input Capacitors
6. Select Feedback Resistors
7. Select Compensator Components
8. Select MOSFET(s)
9. Select Diode

**1. Define Operational Parameters**

Before beginning the design, define the operating parameters of the application. These include:

- V<sub>IN(min)</sub>: minimum input voltage [V]
- V<sub>IN(max)</sub>: maximum input voltage [V]
- V<sub>OUT</sub>: output voltage [V]
- I<sub>OUT(max)</sub>: maximum output current [A]
- I<sub>CL</sub>: desired typical cycle-by-cycle current limit [A]

From this the ideal minimum and maximum duty cycles can be calculated as follows:

$$D_{min} = 1 - \frac{V_{IN(max)}}{V_{OUT}}$$

$$D_{max} = 1 - \frac{V_{IN(min)}}{V_{OUT}}$$

Both duty cycles will actually be higher due to power loss in the conversion. The exact duty cycles will depend on conduction and switching losses. If the maximum input

voltage is higher than the output voltage, the minimum duty cycle will be negative. This is because a boost converter cannot have an output lower than the input. In situations where the input is higher than the output, the output will follow the input, minus the diode drop of the output diode and the converter will not attempt to switch.

If the calculated D<sub>max</sub> is higher the D<sub>max</sub> of the NCV8871, the conversion will not be possible. It is important for a boost converter to have a restricted D<sub>max</sub>, because while the ideal conversion ration of a boost converter goes up to infinity as D approaches 1, a real converter's conversion ratio starts to decrease as losses overtake the increased power transfer. If the converter is in this range it will not be able to regulate properly.

If the following equation is not satisfied, the device will skip pulses at high V<sub>IN</sub>:

$$\frac{D_{min}}{f_s} \geq t_{on(min)}$$

Where: f<sub>s</sub>: switching frequency [Hz]  
 t<sub>on(min)</sub>: minimum on time [s]

**2. Select Current Sense Resistor**

Current sensing for peak current mode control and current limit relies on the MOSFET current signal, which is measured with a ground referenced amplifier. The easiest method of generating this signal is to use a current sense resistor from the source of the MOSFET to device ground. The sense resistor should be selected as follows:

$$R_s = \frac{V_{CL}}{I_{CL}}$$

Where: R<sub>S</sub>: sense resistor [Ω]  
 V<sub>CL</sub>: current limit threshold voltage [V]  
 I<sub>CL</sub>: desire current limit [A]

**3. Select Output Inductor**

The output inductor controls the current ripple that occurs over a switching period. A high current ripple will result in excessive power loss and ripple current requirements. A low current ripple will result in a poor control signal and a slow current slew rate in case of load steps. A good starting point for peak to peak ripple is around 10% of the inductor current at the maximum load at the worst case V<sub>IN</sub>, but operation should be verified empirically. The worst case V<sub>IN</sub> is half of V<sub>OUT</sub>, or whatever V<sub>IN</sub> is closest to half of V<sub>IN</sub>. After choosing a peak current ripple value, calculate the inductor value as follows:

$$L = \frac{V_{IN(WC)}^2 D_{WC}}{\Delta I_{L,max} f_s V_{OUT}}$$

Where: V<sub>IN(WC)</sub>: V<sub>IN</sub> value as close as possible to half of V<sub>OUT</sub> [V]  
 D<sub>WC</sub>: duty cycle at V<sub>IN(WC)</sub>  
 ΔI<sub>L,max</sub>: maximum peak to peak ripple [A]

The maximum average inductor current can be calculated as follows:

$$I_{L,avg} = \frac{V_{OUT} I_{OUT(max)}}{V_{IN(min)}}$$

The Peak Inductor current can be calculated as follows:

$$I_{L,peak} = I_{L,avg} + \frac{V_{IN(min)}^2 D_{max}}{L f_s V_{OUT}}$$

Where:  $I_{L,peak}$ : Peak inductor current value [A]

#### 4. Select Output Capacitors

The output capacitors smooth the output voltage and reduce the overshoot and undershoot associated with line transients. The steady state output ripple associated with the output capacitors can be calculated as follows:

$$V_{OUT(ripple)} = \frac{I_{OUT(max)}(V_{OUT} - V_{IN(min)})}{(C_{OUT} f)^2} + \frac{I_{OUT(max)} V_{OUT} R_{ESR}}{V_{IN(min)}}$$

The capacitors need to survive an RMS ripple current as follows:

$$I_{Cout(RMS)} = I_{OUT} \sqrt{\frac{V_{OUT} - V_{IN(min)}}{V_{IN(min)}}}$$

The use of parallel ceramic bypass capacitors is strongly encouraged to help with the transient response.

#### 5. Select Input Capacitors

The input capacitor reduces voltage ripple on the input to the module associated with the ac component of the input current.

$$I_{Cin(RMS)} = \frac{V_{IN(WC)}^2 D_{WC}}{L f_s V_{OUT} 2\sqrt{3}}$$

#### 6. Select Feedback Resistors

The feedback resistors form a resistor divider from the output of the converter to ground, with a tap to the feedback pin. During regulation, the divided voltage will equal  $V_{ref}$ . The lower feedback resistor can be chosen, and the upper feedback resistor value is calculated as follows:

$$R_{upper} = R_{lower} \frac{(V_{out} - V_{ref})}{V_{ref}}$$

The total feedback resistance ( $R_{upper} + R_{lower}$ ) should be in the range of 1 k $\Omega$  – 100 k $\Omega$ .

#### 7. Select Compensator Components

Current Mode control method employed by the NCV8871 allows the use of a simple, Type II compensation to optimize the dynamic response according to system requirements.

#### 8. Select MOSFET(s)

In order to ensure the gate drive voltage does not drop out the MOSFET(s) chosen must not violate the following inequality:

$$Q_{g(total)} \leq \frac{I_{drv}}{f_s}$$

Where:  $Q_{g(total)}$ : Total Gate Charge of MOSFET(s) [C]

$I_{drv}$ : Drive voltage current [A]

$f_s$ : Switching Frequency [Hz]

The maximum RMS Current can be calculated as follows:

$$I_{D(max)} = I_{out} \sqrt{D}$$

The maximum voltage across the MOSFET will be the maximum output voltage, which is the higher of the maximum input voltage and the regulated output voltage:

$$V_{Q(max)} = V_{OUT(max)}$$

#### 9. Select Diode

The output diode rectifies the output current. The average current through diode will be equal to the output current:

$$I_{D(avg)} = I_{OUT(max)}$$

Additionally, the diode must block voltage equal to the higher of the output voltage and the maximum input voltage:

$$V_{D(max)} = V_{OUT(max)}$$

The maximum power dissipation in the diode can be calculated as follows:

$$P_D = V_{f(max)} I_{OUT(max)}$$

Where:  $P_d$ : Power dissipation in the diode [W]

$V_{f(max)}$ : Maximum forward voltage of the diode [V]

#### Low Voltage Operation

If the input voltage drops below the UVLO or MOSFET threshold voltage, another voltage may be used to power the device. Simply connect the voltage you would like to boost to the inductor and connect the stable voltage to the VIN pin of the device. In boost configuration, the output of the converter can be used to power the device. In some cases it may be desirable to connect 2 sources to VIN pin, which can be accomplished simply by connecting each of the sources through a diode to the VIN pin.

# NCV8871

## PACKAGE DIMENSIONS

SOIC-8 NB  
CASE 751-07  
ISSUE AK

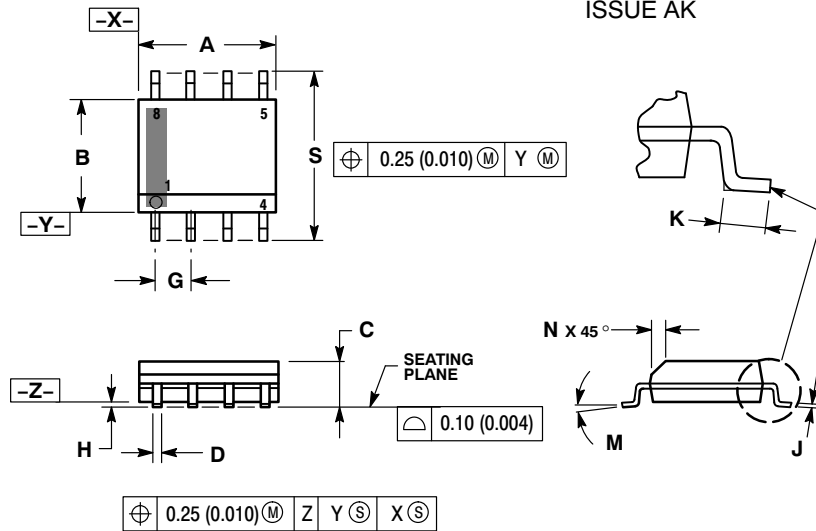

### NOTES:

- DIMENSIONING AND TOLERANCING PER ANSI Y14.5M, 1982.
- CONTROLLING DIMENSION: MILLIMETER.
- DIMENSION A AND B DO NOT INCLUDE MOLD PROTRUSION.
- MAXIMUM MOLD PROTRUSION 0.15 (0.006) PER SIDE.
- DIMENSION D DOES NOT INCLUDE DAMBAR PROTRUSION. ALLOWABLE DAMBAR PROTRUSION SHALL BE 0.127 (0.005) TOTAL IN EXCESS OF THE D DIMENSION AT MAXIMUM MATERIAL CONDITION.
- 751-01 THRU 751-06 ARE OBSOLETE. NEW STANDARD IS 751-07.

DIM	MILLIMETERS		INCHES	
	MIN	MAX	MIN	MAX
A	4.80	5.00	0.189	0.197
B	3.80	4.00	0.150	0.157
C	1.35	1.75	0.053	0.069
D	0.33	0.51	0.013	0.020
G	1.27 BSC		0.050 BSC	
H	0.10	0.25	0.004	0.010
J	0.19	0.25	0.007	0.010
K	0.40	1.27	0.016	0.050
M	0 <sup>°</sup>	8 <sup>°</sup>	0 <sup>°</sup>	8 <sup>°</sup>
N	0.25	0.50	0.010	0.020
S	5.80	6.20	0.228	0.244

### SOLDERING FOOTPRINT\*

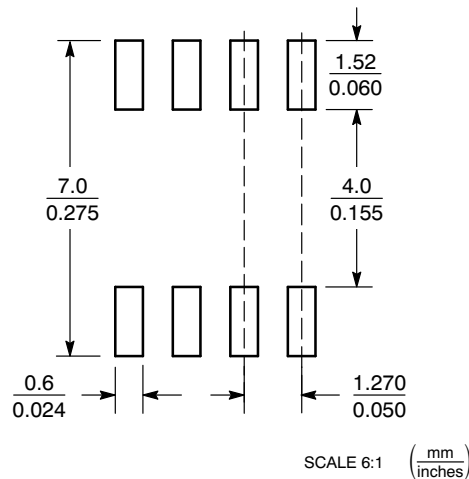

\*For additional information on our Pb-Free strategy and soldering details, please download the ON Semiconductor Soldering and Mounting Techniques Reference Manual, SOLDERRM/D.

ON Semiconductor and are registered trademarks of Semiconductor Components Industries, LLC (SCILLC). SCILLC reserves the right to make changes without further notice to any products herein. SCILLC makes no warranty, representation or guarantee regarding the suitability of its products for any particular purpose, nor does SCILLC assume any liability arising out of the application or use of any product or circuit, and specifically disclaims any and all liability, including without limitation special, consequential or incidental damages. "Typical" parameters which may be provided in SCILLC data sheets and/or specifications can and do vary in different applications and actual performance may vary over time. All operating parameters, including "Typicals" must be validated for each customer application by customer's technical experts. SCILLC does not convey any license under its patent rights nor the rights of others. SCILLC products are not designed, intended, or authorized for use as components in systems intended for surgical implant into the body, or other applications intended to support or sustain life, or for any other application in which the failure of the SCILLC product could create a situation where personal injury or death may occur. Should Buyer purchase or use SCILLC products for any such unintended or unauthorized application, Buyer shall indemnify and hold SCILLC and its officers, employees, subsidiaries, affiliates, and distributors harmless against all claims, costs, damages, and expenses, and reasonable attorney fees arising out of, directly or indirectly, any claim of personal injury or death associated with such unintended or unauthorized use, even if such claim alleges that SCILLC was negligent regarding the design or manufacture of the part. SCILLC is an Equal Opportunity/Affirmative Action Employer. This literature is subject to all applicable copyright laws and is not for resale in any manner.

### PUBLICATION ORDERING INFORMATION

LITERATURE FULFILLMENT:  
Literature Distribution Center for ON Semiconductor  
P.O. Box 5163, Denver, Colorado 80217 USA  
Phone: 303-675-2175 or 800-344-3860 Toll Free USA/Canada  
Fax: 303-675-2176 or 800-344-3867 Toll Free USA/Canada  
Email: orderlit@onsemi.com

N. American Technical Support: 800-282-9855 Toll Free  
USA/Canada  
Europe, Middle East and Africa Technical Support:  
Phone: 421 33 790 2910  
Japan Customer Focus Center  
Phone: 81-3-5817-1050

ON Semiconductor Website: [www.onsemi.com](http://www.onsemi.com)

Order Literature: <http://www.onsemi.com/orderlit>

For additional information, please contact your local Sales Representative